

WINGET

OPERATING INSTRUCTIONS & SPARE PARTS LIST 4C4000 & 4C5000 DUMPER

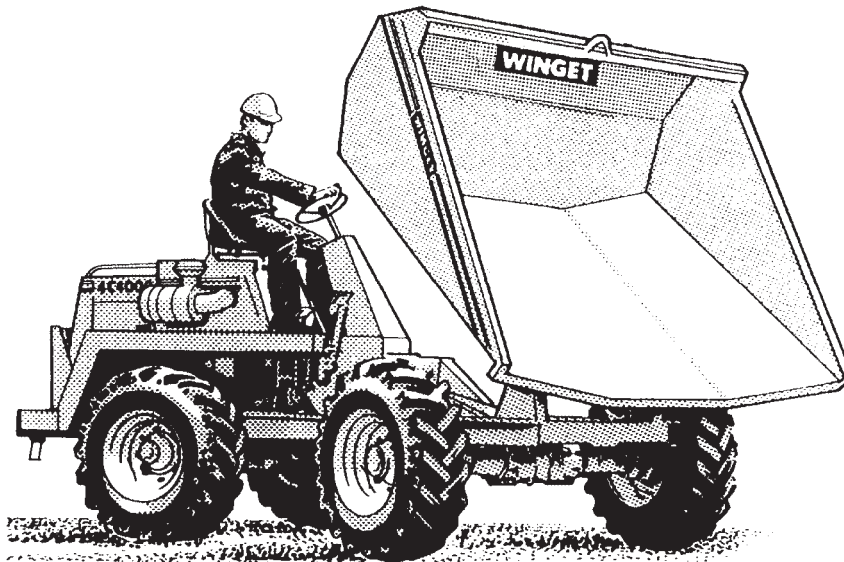

ISSUED MAY 1990
REPRINTED OCTOBER 2002

WINGET LIMITED
PO BOX 41
EDGEFOLD INDUSTRIAL ESTATE
PLODDER LANE
BOLTON
LANCS
BL4 OLS

TEL: ++ 44 (0) 1204 854650

FAX: ++ 44 (0) 1204 854663

service@winget.co.uk

parts@winget.co.uk

www.winget.co.uk

INTRODUCTION

This Parts & Operators Manual is a re-print of the Operators Manual Part No V601321 last published in 1990 and contains some amended part numbers.

Health & Safety legislation and working practices applicable to Site Dumpers, both 2 and 4 wheel Drive, Rigid Chassis and Articulated Chassis have changed considerably in the years since this manual was last published and immediately following this Introduction are notes on the Safe Use of Site Dumpers. These notes supersede and replace all previous 'Dumper Safety' notes issued with Winget 4C4000 & 4C5000 Four Wheel Drive Dumpers.

The contents of this manual although correct at the time of publication, may be subject to alteration by the manufacturers without notice and Winget Limited can accept no responsibility for any errors or omissions contained within the following pages. Nor can we accept any liability whatsoever arising from the use of this manual howsoever caused.

Winget Limited operate a policy of continuous product development. Therefore, some illustrations or text within this publication may differ from your machine.

WINGET LIMITED
PO BOX 41
EDGEFOLD INDUSTRIAL ESTATE
PLODDER LANE
BOLTON
LANCS
BL4 OLS
TEL ++ 44 (0) 1204 854650
FAX ++ 44 (0) 1204 854663
E mail service@winget.co.uk
parts@winget.co.uk
www.winget.co.uk

DUMPER SAFETY

Safety is the responsibility of all persons working with this machine. Think "safety" at all times. Read and remember the contents of this handbook.

MACHINE MODIFICATIONS

WARNING Any modifications to the machine will affect its working parameters and safety factors. Refer to the Manufacturers before fitting any non-standard equipment or parts.



The Manufacturers accept no responsibility for any modifications made after the machine has left the factory, unless previously agreed by the Manufacturers in writing; the Manufacturers will accept no liability for damage to property, personnel or the machine if failure is brought about due to such modifications, or fitment of spurious parts.

TRAINING

WARNING Only trained operators should use this machine.



Operators should hold an appropriate full motor vehicle driving licence and undergo both a safety awareness course and a driver training course for Site dumpers run by the C.ITB or equivalent body leading to the award of a CTA.

It is strongly recommended that operators read the H.S.E. publication "Safe Working with Small Dumpers" which is available from government bookshops (HMSO) or from other bookshops quoting the following number ISBN 011 8836935. Another useful publication is British Standard number BS 6264, "Procedure for Operator Training For Earth Moving Machinery" available from the British Standard Institution.

OPERATION

WARNING *NEVER* use the machine for purposes other than those for which it was designed. This machine was designed to carry loads such as soil, clay, sand, wet concrete, stone or other similar materials. It was not designed to carry loads which may move around in the skip uncontrollably, nor to carry any loads or materials which overhang the skip in any way. If in any doubt as to the suitability of this machine for a particular task, contact your nearest Distributor or the Manufacturer for advice.



ALWAYS be aware of local and national regulations governing the use of the machine.

NEVER commence work with the machine until the "Daily (or every ten hours)" service checks have been made. (See *Service Section* for details)

ALWAYS check wheel nut tightness daily.

NEVER carry passengers.

Where seat belt restraints are fitted as part of Rops/Fops Protection they must be worn. Ensure that the seat and seat belt are securely fixed to the machine. Check that the seat belt is in good condition, free from cuts and frayed edges.

ALWAYS remain in the driving seat whenever the engine is running. Never attempt to operate any controls unless seated.

ALWAYS apply the parking brake before leaving the driver's seat.



DUMPER SAFETY

NEVER dismount with the engine running, and never leave the machine unattended with the key in the starter switch.

When Battery Isolators are fitted they must be activated only when the engine is turned off except in cases of emergency.

Activating a Battery Isolator when the engine is running can result in damage to the electrical components and circuits.

NEVER fill the fuel or hydraulic tanks with the engine running.

ALWAYS drive only on surfaces that are known to be stable.

ALWAYS keep the floor plates and walkways clean.

NEVER drive the machine close to the edge of any excavation. Always use effective wheel stops to prevent the machine running close to the edge. Make sure that the stops are in proportion to the size of the wheels and are set sufficiently far enough back from the edge of any excavation to prevent the weight of the load causing a collapse.

NEVER adjust the tyre pressures in an attempt to improve traction on soft ground or obtain a softer ride on hard ground. Incorrectly adjusted tyres can affect the steering and handling characteristics.

NEVER attempt to free a machine which is 'bogged down' by pushing with the bucket of a backhoe loader, tracked excavator or other similar machine.

NEVER make unnecessary "crash stops" when travelling at speed, especially in forward direction.

NEVER work under an unpropped skip. *If the dumper was supplied with a special Skip Support always ensure that it is used.*

Some articulating dumpers are manufactured with an articulation lock. If your machine has this feature proceed as follows:

ALWAYS fit the articulation lock when working within the articulation point crush zone.

NEVER attempt to lift the machine unless the articulation lock is engaged.

SKIPS AND LOADING

WARNING *NEVER* exceed the rated payload. The weights of all loads above skip water level must be checked.



NEVER remain on the machine when loading the skip with excavators or loaders. Stop the engine, apply the parking brake, dismount, and stand well clear.

ALWAYS ensure that the load is evenly distributed in the skip.

NEVER carry loads or heap materials in such a manner as to affect the forward vision.

ALWAYS take extra care when tipping non free running loads.

NEVER use the skip in a tipped position to bulldoze heaped materials level or to backfill material into excavations.

DUMPER SAFETY

TOWING

WARNING NEVER attempt to start the engine of a dumper by towing or pushing.



Dumpers are not designed as towing vehicles, but loads (including weight of trailer) not exceeding the rated payload of the dumper may be towed on dry level ground in first gear, providing the dumper skip is loaded with half the rated payload to ensure tyre adhesion when braking.

ALWAYS use a purpose made towing pin.

NEVER tow loads up, down or across gradients.

GRADIENTS

WARNING NEVER operate *Four Wheel Drive articulated steer dumpers* on any gradients which exceed 25% (1 in 4), or across gradients which exceed 16% (1 in 6).



NEVER operate *Two Wheel Drive rigid chassis dumpers* on any gradients which exceed 10% (1 in 10), or across gradients which exceed 10% (1 in 10).

ALWAYS remember that slippery or loose surface conditions can adversely affect safe machine operation, including braking, particularly on gradients.

ALWAYS choose routes that avoid steep, slippery or loose gradients.

NEVER coast down gradients. Always negotiate gradients in first gear.

ALWAYS drive forwards up gradients when loaded.

ALWAYS reverse down gradients when loaded.

ALWAYS keep the load facing uphill.

NEVER park on a gradient. If this is unavoidable, ALWAYS chock the wheels.

NEVER attempt to turn on a gradient.

NEVER tow up, down or across a gradient.

NEVER operate high discharge or rotating skips on gradients.

HYDRAULICS

WARNING ALWAYS "Dump" residual pressure from the system before leaving the machine or before carrying out any maintenance or adjustments.



If maintenance work requires the skip to be in the raised position, then it must be raised and supported before dumping the pressure.

Dump pressure by switching off the engine, then moving the hydraulic control lever several times in each direction.

NEVER leave the machine unattended with pressure in the system.

ALWAYS purge hydraulic rams before commencing work. With the engine running operate the hydraulic control to fully extend and retract the rams.

ALWAYS practise the greatest cleanliness in maintaining hydraulic components.

DUMPER SAFETY

SERVICING

WARNING ALWAYS report any defect at once, before an accident or consequential damage can occur.



ALWAYS conform to service schedules except where:

- 1 Warning lights or warning indicators call for immediate attention.
- 2 Adverse conditions necessitate more frequent servicing.

ALWAYS wear correctly fitting protective clothing. Loose or baggy clothing can be extremely dangerous when working on running engines or machinery.

ALWAYS, where possible, work on or close to engines or machinery only when they are stopped. If this is not practical, remember to keep tools, test equipment and all parts of your body well away from the moving parts.

ALWAYS dump pressure from the hydraulic system before carrying out any kind of maintenance or adjustment. (*see Hydraulics Warnings*).

ALWAYS avoid contact with exhaust pipes, exhaust manifolds and silencers when the engine is running; these can be very hot.

ALWAYS work out of doors, or in a well-ventilated area.

NEVER run an engine in an enclosed space. Exhaust fumes in enclosed areas can kill.

ALWAYS disconnect battery cables and remove battery before using an external charger, carrying out welding repairs or to prevent unauthorised usage when unattended or during a repair.

NEVER allow unqualified personnel to attempt to repair, remove or replace any part of the machine, or anyone to remove large or heavy components without adequate lifting tackle.

NEVER attempt to modify or repair Rops Frames or Fops Canopies by welding, drilling or any other means. Attempts to do so will invalidate Rops/Fops Certification.

ALWAYS obtain advice before mixing oils; some are incompatible. If in doubt drain and refill.

NEVER allow oils and fuels to come into regular contact with skin. This can lead to serious skin diseases including, medical evidence suggests, skin cancer. ALWAYS wear protective gloves when handling oils and fuels whether topping up, draining or refilling. ALWAYS wash hands if oils or fuels come into contact with the skin.

Many liquids used in this machine are harmful if taken internally or splashed into the eyes. In the event of accidentally swallowing oils, fuels, anti-freeze, battery acid etc, DO NOT encourage vomiting, seek qualified medical assistance immediately.

ALWAYS dispose of waste oils and fuels into waste oil storage tanks. If storage tanks are not available consult your distributor or local authority for addresses of local designated disposal points. It is illegal to dispose of waste oil into drains or water courses or to bury it.

DUMPER SAFETY

Equipment which includes friction materials will sometimes contain asbestos. When removing friction material dust from components, such as when servicing brakes or clutches, do not blow out with an airline; it could be harmful to inhale the dust. Remove the dust with a vacuum cleaner or wipe clean with a damp rag. Waste should be placed in a sealed container, marked, and disposed of in accordance with local or national regulations.

The accumulated dust found in clutch housings may contain lead/antimony. No food should be eaten at a work place contaminated by this dust. Hands must be washed before eating. Do not blow out dust with an airline.

ALWAYS ensure that the starting handle is clean and in good condition. Keep the engine starting dog, and the part of the starting handle that mates with it, lightly lubricated (*Refer to the Engine Handbook*).

NEVER work under an unpropped skip. ***If the dumper was supplied with a special Skip Support always ensure that it is used.***

Some articulating dumpers are manufactured with an articulation lock. If your machine has this feature, ALWAYS fit the articulation lock when servicing or working on the machine.

INTRODUCTION**SAFE WORKING****SECTION****1****OPERATION**

<u>DRIVING THE DUMPER</u>	<u>1.1</u>
---------------------------	------------

SECTION**2****SERVICE**

<u>ACCESS TO CHECKPOINTS</u>	<u>2.1</u>
<u>SERVICE SCHEDULES</u>	<u>2.2</u>
<u>HYDRAULIC SYSTEM</u>	<u>2.10</u>
<u>BRAKE SYSTEM</u>	<u>2.12</u>
<u>SPECIFICATIONS</u>	<u>2.14</u>
LUBRICANTS & FLUIDS	2.14
ADJUSTMENTS	2.15
CAPACITIES - FLUID	2.15
PRESSURES	2.15
DIMENSIONS	2.16
<u>WIRING DIAGRAM</u>	<u>2.17</u>

PARTS

All data given in this handbook are subject to production variations. For further information contact your nearest Distributor or the Manufacturers.

May 1990 / 250 / issue 04 / 505016

INTRODUCTION

This operator's handbook is designed to assist with the safe operation and servicing of your machine.

For maximum operational life, we recommend that you carefully follow the service and maintenance schedules set out in this book.

RUNNING-IN

The "running-in" period of your machine is extremely important, and the following instructions should be followed very closely during the first fifty hours of operation.

- 1 Avoid overloading the engine.
- 2 Use the lower gears when operating with heavy loads.

3 Keep the oil compartments and the hydraulic reservoirs filled to their recommended levels.

4 Avoid prolonged 'no load' operation at either high or low engine speeds.

Operating in this way throughout the machine's life will prove beneficial to its overall performance.

FIRST 50 HOUR SERVICE

After one month or fifty hours' work the machine must be serviced by your distributor.

See also the Warranty Registration Booklet.

Distributor

MACHINE IDENTIFICATION

Please record the model and serial numbers of your machine in the spaces provided and quote them when ordering parts.

Model - year _____

Machine serial number _____

Key, start _____

Engine _____

Transmission unit _____

Gearbox _____

Transfer gearbox _____

Front axle _____

Rear axle _____

Ram, steering _____

Ram, tipping, L.H. _____

Ram, tipping, R.H. _____

Safety is the responsibility of all persons working with this machine. Think "safety" at all times. Read and remember the contents of this handbook.

OPERATION

- ALWAYS** ensure that only skilled personnel operate this machine.
- ALWAYS** be aware of local and national regulations governing the use of the machine.
- ALWAYS** drive only on surfaces that are known to be stable.
- ALWAYS** remain in the driving seat whenever the engine is running.
- ALWAYS** take extra care when tipping non free running loads.
- NEVER** use the machine for purposes other than those for which it was designed.
- NEVER** make unnecessary "crash" stops when travelling at speed, especially in forward direction.
- NEVER** carry passengers.
- NEVER** drive the machine close to the edge of any excavation.
- NEVER** fill the fuel tank with the engine running.
- NEVER** dismount with the machine in motion.

LOAD CARRYING

- NEVER** exceed the rated payload.

TOWING

- WARNING** Dumpers are not designed as towing vehicles, but loads (including weight of trailer) not exceeding the rated payload of the dumper may be towed on level ground in first gear, providing the dumper is loaded with half the rated payload to ensure tyre adhesion when braking.

GRADIENTS

- ALWAYS** keep the load facing up-hill.
- ALWAYS** drive forwards up gradients when loaded.
- ALWAYS** reverse down gradients when loaded.
- ALWAYS** remember that slippery or loose surface conditions can adversely affect safe machine operation, particularly on gradients.
- ALWAYS** choose routes that avoid steep, slippery or loose gradients.
- NEVER** park the machine on a gradient.
- NEVER** attempt to turn on, or drive across, a gradient.
- NEVER** tow down gradients.

SAFE WORKING

HYDRAULICS

- ALWAYS** 'dump' pressure from the system before carrying out any maintenance or adjustments.
- ALWAYS** purge hydraulic cylinders before commencing work. With the engine running, operate the hydraulic control to fully extend and retract the rams.
- NEVER** leave the machine unattended with pressure in the system.
- ALWAYS** practice the greatest cleanliness in maintaining hydraulic components.

MAINTENANCE

- ALWAYS** conform to service schedules except where:
 - (a) a warning light illuminates
 - (b) adverse conditions necessitate more frequent servicing.
- ALWAYS** report any defect at once, before an accident or consequential damage can occur.
- ALWAYS** disconnect battery cables before using an external charger, or to prevent unauthorized usage when unattended or during a repair.
- ALWAYS** obtain advice before mixing oils; some are incompatible.
- NEVER** allow unqualified personnel to attempt to remove or replace any part of the machine, or anyone to remove large or heavy components without adequate lifting tackle.

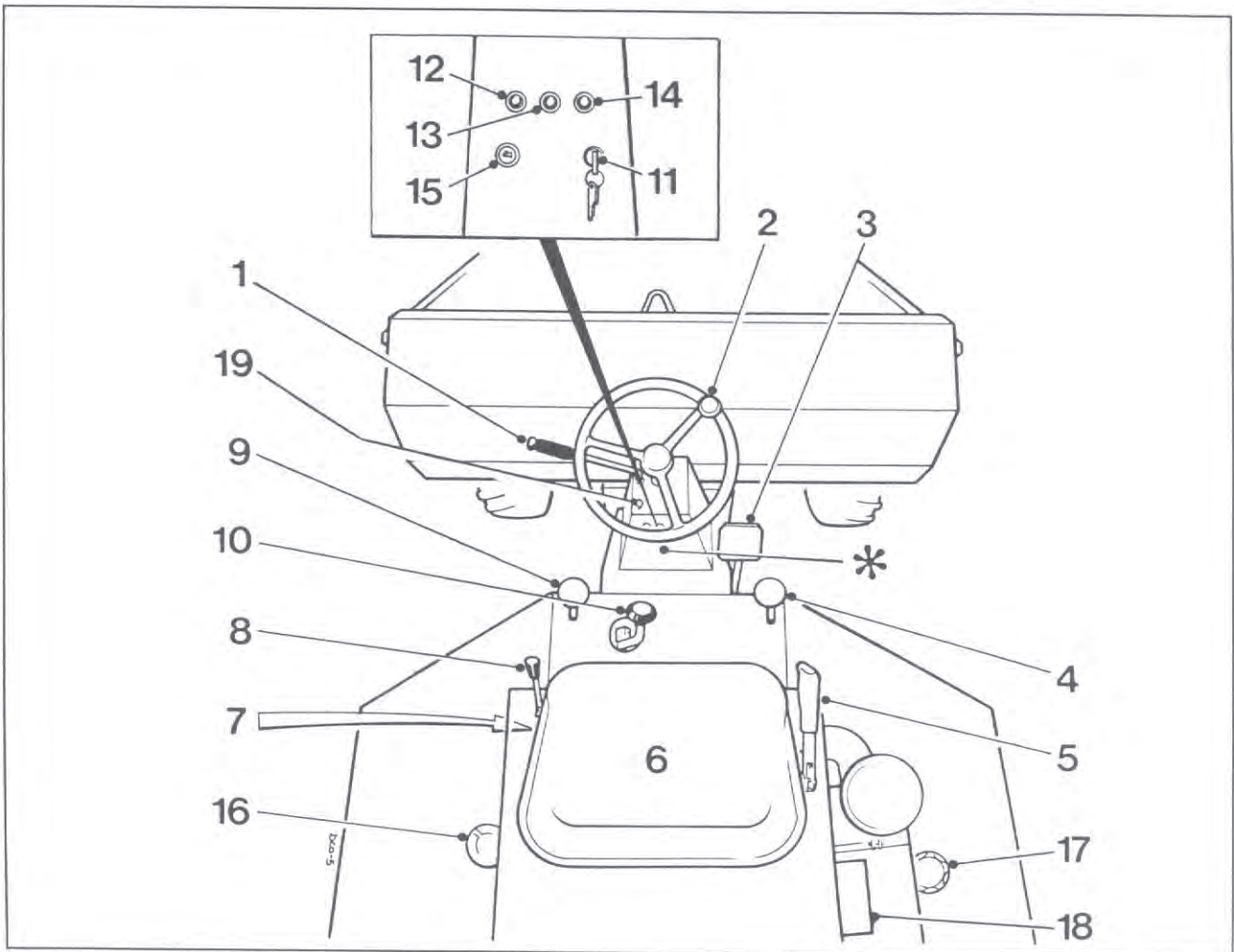

- 1 Forward/reverse control
- 2 Steering wheel
- 3 Foot brake
- 4 Accelerator pedal
- 5 Parking brake
- 6 Seat
- 7 Engine stop control
- 8 Skip control, tip/return
- 9 Transmission disconnect pedal (gear change)
- 10 Gear lever
- 11 Key-start switch
- 12 Warning light - battery charge
- 13 Warning light - engine oil pressure
- 14 Warning light - fan belt
- * Audible warning (fan belt)
- 15 Horn
- 16 Fuel tank
- 17 Hydraulic tank
- 18 Brake oil reservoirs
- 19 Warning light - parking brake engaged

DRIVING THE DUMPER

Pre-start check

NEVER commence work with a new, unfamiliar or long standing machine until a "daily or 10 hour" service has been carried out. (see *Service Schedule*).

Starting the dumper

Ensure parking brake is in the raised "ON" position. (The warning light should illuminate)

Both gear levers must be in neutral before the engine will start.

Engine stop control must be fully in.

Accelerator is set for quarter speed.

- * Off
- A Warning lights
- B Starter

Turn the starter key to 'A' for:

WARNING LIGHTS

- Battery charging.
- Engine oil pressure.
- Parking brake engaged

Turn starter key to 'B' for:

STARTER - hold for a maximum of 30 seconds.

Release key when engine runs.
Check warning lights have gone out.

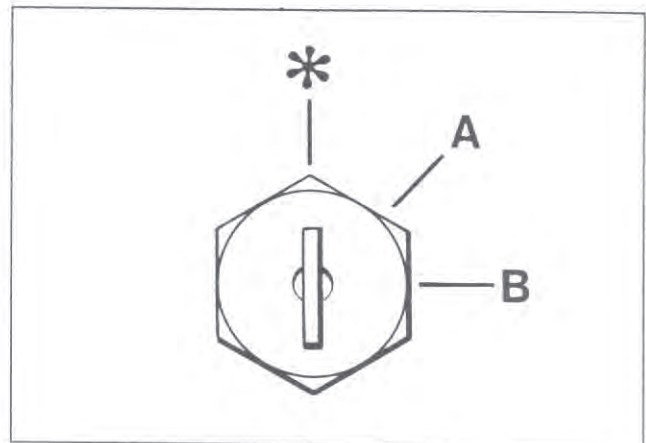

To engage gear levers:

The transmission is controlled by two levers.

Lever (1) operates the forward and reverse clutches, and lever (3) operates the four gears.

IMPORTANT: When changing gear, always depress the transmission disconnect pedal, (2), before moving the gear lever, (3), from one gear to another.

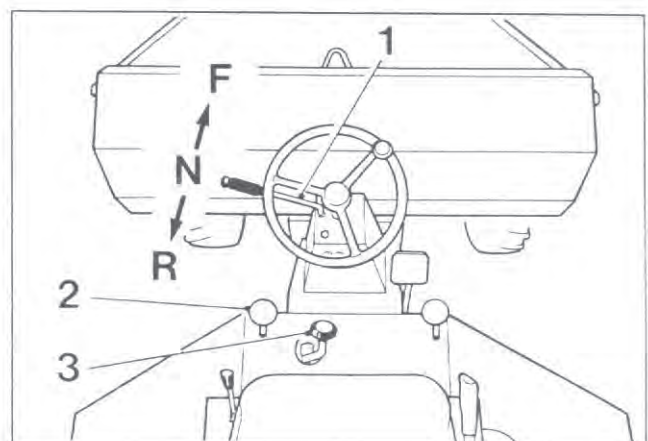

To select forward travel:

- a The engine must be at idling speed
- b Engage a gear with lever (3) and move lever (1) into forward position.
- c Release parking brake
- d Accelerate engine.

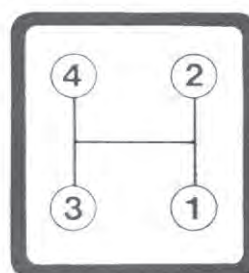

To change gear, depress pedal **(2)** and move gear lever smoothly to the next higher or lower gear.

To change direction of travel:

- a Reduce the engine speed.
- b Brake to a stop.
- c Move lever **(1)** from forward to reverse.
- d Accelerate the engine.

NEVER operate in too high a gear as this will cause the torque converter to slip and overheat.

Steering

NEVER hold the steering on full lock for more than a minute because the excessive use of the relief valve will cause overheating of the components.

Stopping the dumper

Release accelerator and brake to a halt progressively.
Select neutral gear.
Apply parking brake when stationary.
Pull out engine stop control.
Turn key start switch to 'OFF' position.

Leaving the dumper

Operate the hydraulic lever fully in each direction several times to 'dump' hydraulic pressure.

ALWAYS apply parking brake because the transmission will not 'park' if left in gear.

Remove key from switch.

Chock wheels if parked on a slope.

If unattended for some time, remove earth cable from battery.

DRIVING THE DUMPER**Towing the dumper**

NEVER tow the machine above 5mph (8kph) as the lack of power assistance makes manual steering very slow and strenuous.

ALWAYS tow the dumper with both gear levers in neutral.

ACCESS TO SERVICE CHECKPOINTS**To open side covers:**

Twist fastener and pull to open.

This will give access to:

ENGINE: see *engine operation manual*.

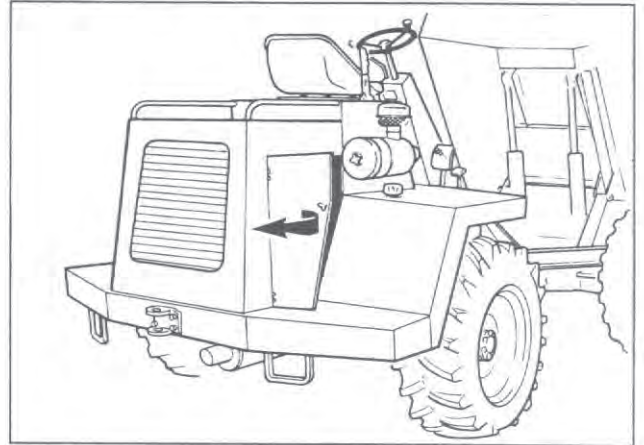
**To remove footplate:**

Unscrew pedal pads.

Remove the screws securing the plate.

This will give access to:

Transmission unit.

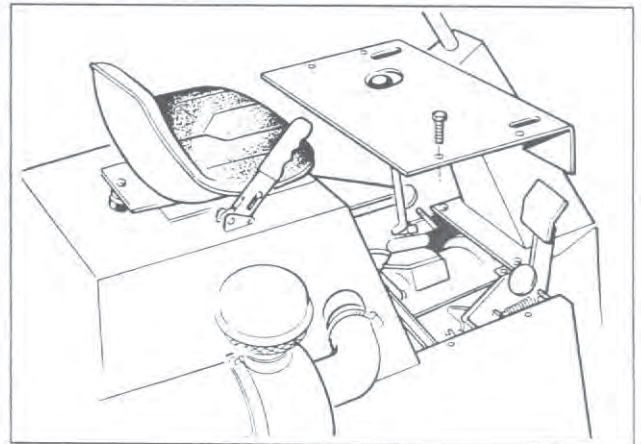

SCHEDULE

Daily or every 10 hours

NEVER commence work with a new, unfamiliar or long standing machine until the following checks have been carried out.

Always check fluid levels on a flat level surface.

Engine oil level

Do not check oil level until the engine has been stopped for 2 minutes.

Remove and clean dipstick (1), then check that the oil is at the full mark. If level is low, top up through the filler (2) to the full mark with clean oil of the correct grade.

DO NOT OVERFILL.

Wheel nuts

Tighten these whenever necessary, every ten hours or daily, and after each wheel change.

Axles

Check for oil leaks around joints and seals.

Brake oil reservoirs

(Machines built after May 1989)

Check oil level. Never allow the oil to fall more than 10mm below top level marks.

Hydraulic oil level

- 1 Oil level when hydraulic rams are closed.
- 2 Dipstick
- 3 Maximum oil level
- 4 Minimum oil level

Do not check oil level before closing tipping rams, and machine has been idle for 2 minutes.

The oil level is correct when between the two marks on the dipstick.

Do not overfill; it will cause leakage from the breather!

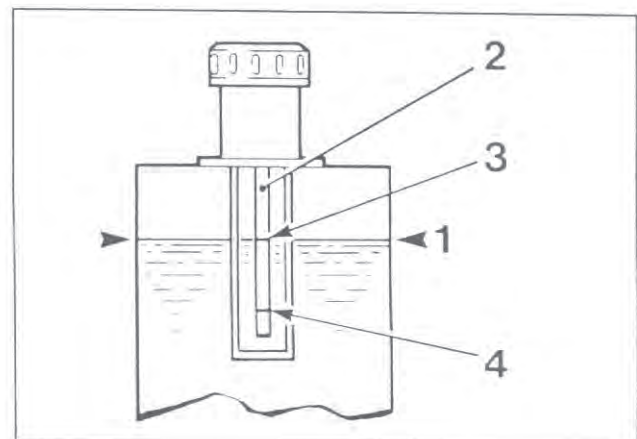
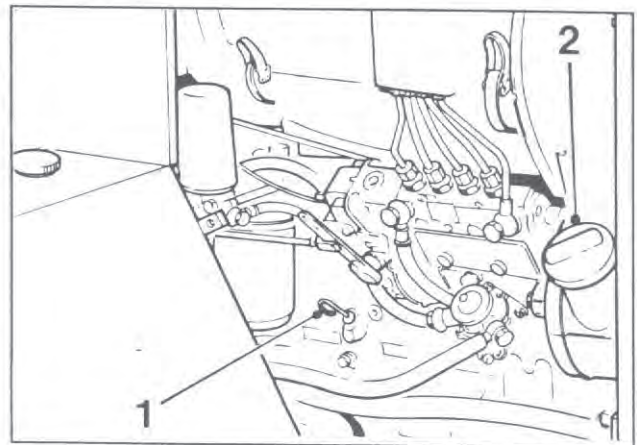

Air Cleaner

With the engine stopped, pinch the rubber dust collector (2) to release the dust. In dirty conditions, remove the filter element (3) from inside the cleaner and tap it on the palm of the hand to release dust. Remove debris from mesh of the pre-cleaner (1) as frequently as necessary.

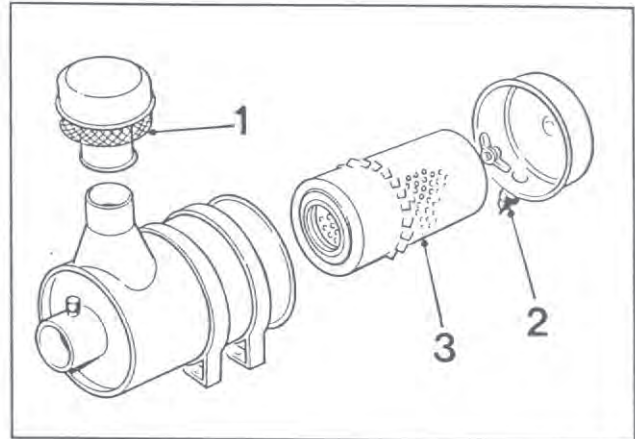

Every 50 hours

Every 50 hours or weekly carry out the following maintenance plus the procedure for the intermediate service

Cooling system

* Clean air passages as often as site conditions necessitate. Clean air is essential to economy and reliability.

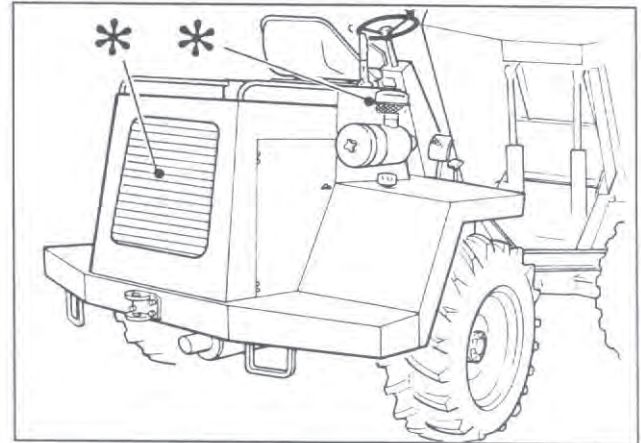

Axles

(Machines built up to May 1989)

Tighten axle arm/main case joint securing nuts and half shaft nuts.

Propeller shafts

Tighten securing nuts.

Tyres

Check the pressures only when the tyres are cold. Set to the pressures shown in the specifications. Check tyres for damage and wear.

Battery

Top up with distilled water to 0.25" (6mm) above the separators.

NEVER add acid or use naked lights.

ALWAYS keep the battery top clean and dry, and the terminals free from corrosion with petroleum jelly.

SCHEDULE

Grease points

Clean nipples before and after greasing.
Apply the grease gun until clean grease appears.

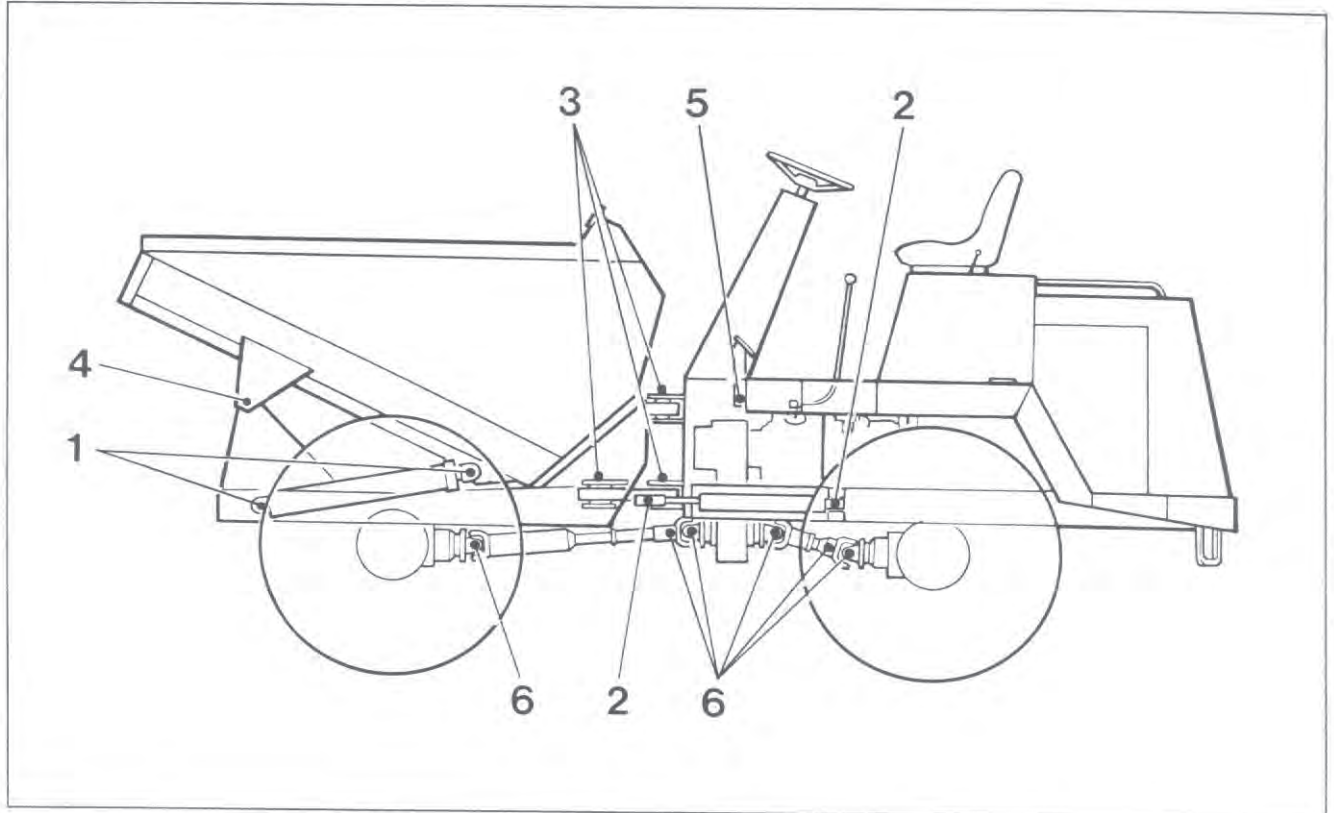

- 1 Grease the nipples on tipping hydraulic rams.
- 2 Grease the nipples on steering hydraulic ram.
- 3 Grease the nipples on chassis centre pivots.
- 4 Grease the nipples on skip pivot pins
- 5 Grease the nipple on the brake pedal pivot.
- 6 Grease the nipples on each of the propeller shafts

Front and rear axle oil levels

Machines built before May, 1989

Do not check the oil level until the machine has stood for 2 minutes.

Clean the areas surrounding the filler/level plugs (1) before removing.

The axle oil levels are correct when oil reaches the level plug holes.

If the oil level is low, top up with clean oil of the correct grade.

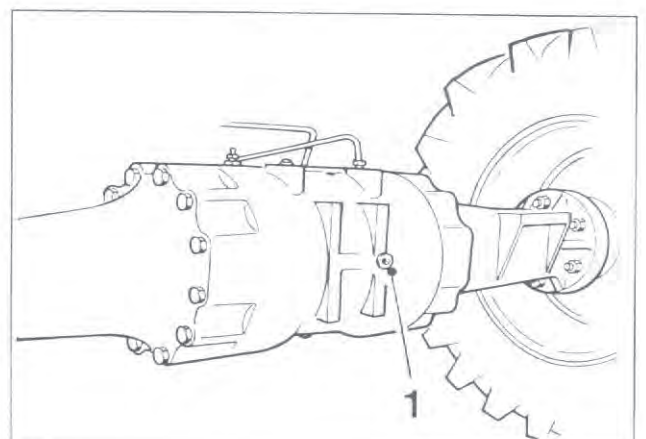

Front and rear axle oil levels

Machines built after May 1989.

Do not check the oil level until the machine has stood for 2 minutes. Clean the areas surrounding the filler/level plugs before removing.

The differential case oil levels are correct when they reach the level plug holes (1). If the oil level is low, top-up with clean oil of the correct grade.

Check each hub oil level individually.

Revolve the hub until the filler/level plug (2) is at the 3 or 9 o'clock position.

Clean the area before removing the plug and check the level.

Top-up if necessary with clean oil of the correct grade.

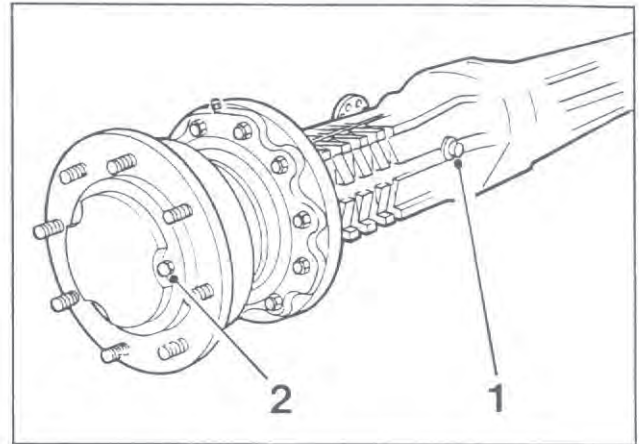

Transmission oil levels

Gearbox oil level

Check the transmission oil level when the machine has stood for 2 minutes.

Remove the filler/level plug (1) and bring the oil level up to the bottom of the filler/level hole. It is most important not to overfill. Allow any surplus to drain out before replacing the level plug.

Transfer gearbox oil level

Check and top-up via the filler plug hole (2) to the level shown by the level plug hole (3).

Hydraulic transmission oil level

With the machine completely level, run the engine at a fast idle for 1 minute to ensure that the torque converter is full of oil.

Check the dipstick (4) while the engine is idling or immediately after stopping the engine.

The correct level is between the low and full mark. Top-up as required at the dipstick/filler cap (4).

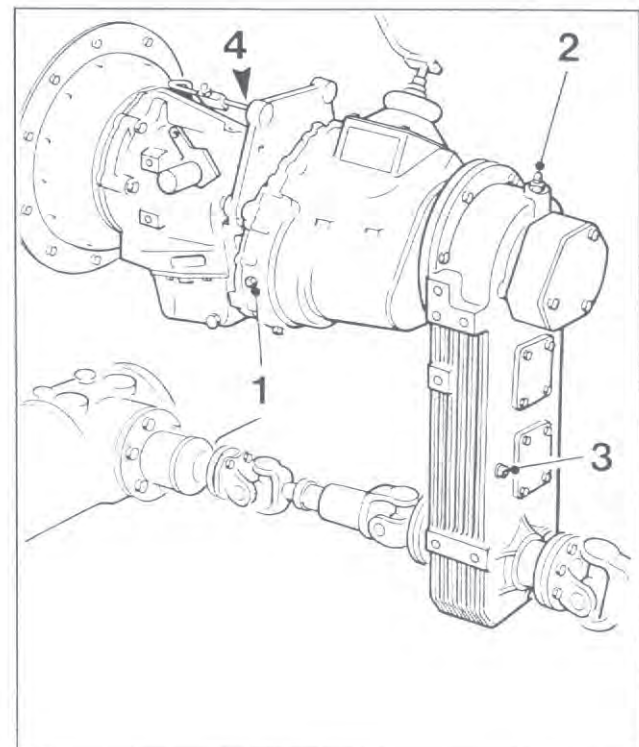

Use the correct oil for each of the three transmission components.

SCHEDULE**Every 250 hours**

Every 250 hours carry out the following maintenance plus the procedure for the intermediate services.

Air Cleaner

Remove the element (1) of the air cleaner and wash it most carefully in hand-hot water and non-sudsing detergent.

Rinse carefully and allow to dry naturally. If the machine is required urgently, either carry out this operation before all the others, or fit a spare element.

NEVER attempt to dry a wet element with any air pressure.

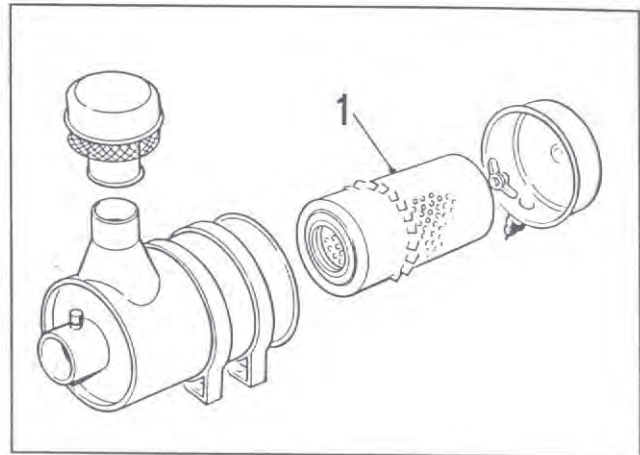
**Every 500 hours**

Every 500 hours carry out the following maintenance plus the procedure for the intermediate services.

Air Cleaner

Remove the element and replace with new element.

Hydraulic oil filter

Remove and discard filter cartridge (1). Clean joint area, wipe with hydraulic oil, and fit new cartridge.

Do not overtighten.

Run the engine to circulate the oil. Operate the hydraulic control to purge any air.

Stop the engine and top up the tank as required.

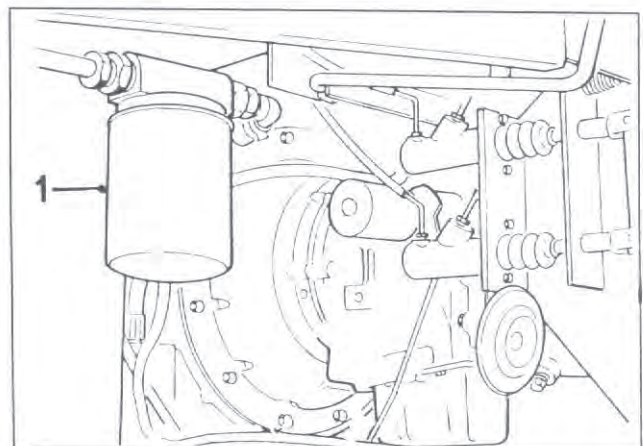

Every 1000 hours

Every 1000 hours or annually carry out the following maintenance plus the procedure for the intermediate services.

Hydraulic oil tank and filter

Run the engine and operate the hydraulics to warm the oil.

Fully close the tipping rams.

Disconnect the battery earth cable.

Operate the hydraulic control lever fully in each direction several times to relieve pressure in the system.

Remove drain plug and drain the oil from the hydraulic tank.

Flush out the tank with clean hydraulic oil, taking extreme care to remove all dirt and foreign matter.

Refit drain plug.

Clean the filler cap breather.

Remove and discard filter cartridge **(1)**. Clean joint area, wipe with hydraulic oil, and fit new cartridge. Do not overtighten.

Refill the tank with clean oil of the correct grade.

Run the engine to circulate the oil.

Operate the hydraulic control to purge any air.

Stop the engine and top up the tank as required.

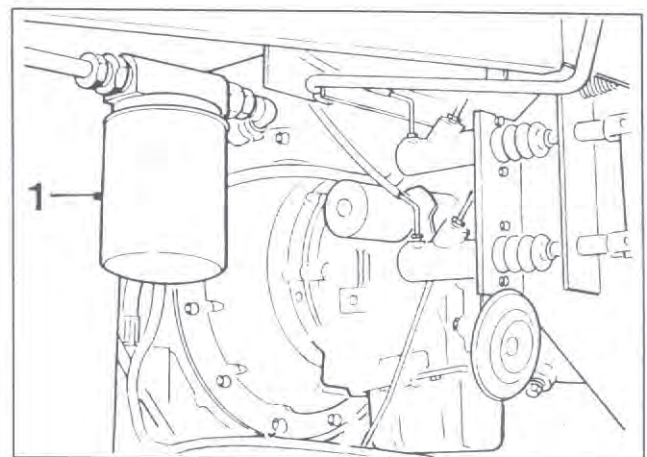

SCHEDULE

Gearbox oil change

Drain the gearbox by removing the plug (2).

Replace drain plug.

Remove the filler/level plug (1) and fill the oil level up to the bottom of the filler/level plug hole. It is most important not to overfill.

Allow any surplus to drain out before replacing the level plug.

Transfer gearbox oil change

Drain oil by removing the plug at the bottom of the casing.

Replace drain plug.

Fill with oil (4) to the level plug (3).

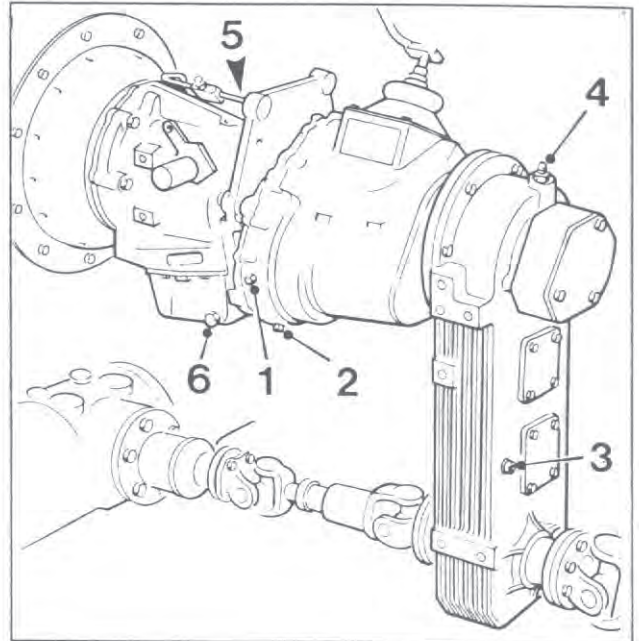
**Hydraulic transmission**

Drain oil by removing plug (6).

Replace drain plug.

Fill with oil at the dipstick/filler cap (5).

Run the engine at fast idle for 1 minute to ensure that the torque converter is full of oil.

Check the dipstick while the engine is idling or immediately after stopping the engine.

The correct level is between the low and full mark. Top-up as required at the dipstick/filler cap (5).

Use the correct oil for each of the three transmission components.

Front and rear axles

Change the lubrication oils in both the front and rear axle.

Before removing plugs, clean the surrounding area.

Axle casing

A Machines built before May 1989

B Machines built from May 1989

Remove drain plug (1) and drain oil. Replace drain plug.

Refill at the level/filler plug (2) with clean

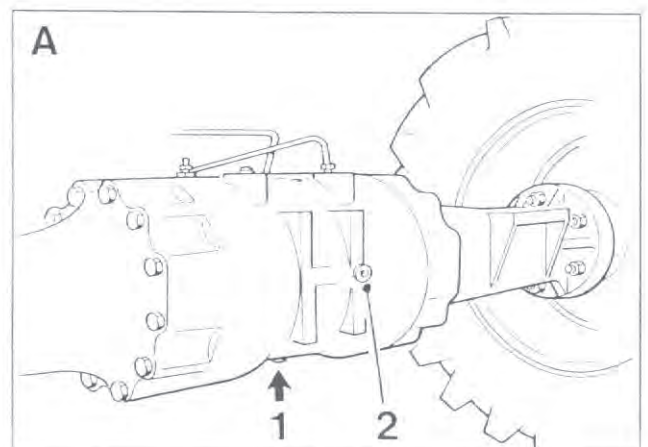

oil of the correct grade.
Replace filler plug.

Hubs

B Machines built from May 1989

Revolve the hubs until the drain/level/filler plug (3) is at the bottom.

Remove plug (3) and drain oil.

Revolve the hubs until the drain holes (3) are at the 3 or 9 o'clock position (4).

Refill with clean oil of the correct grade.

Replace plug (4).

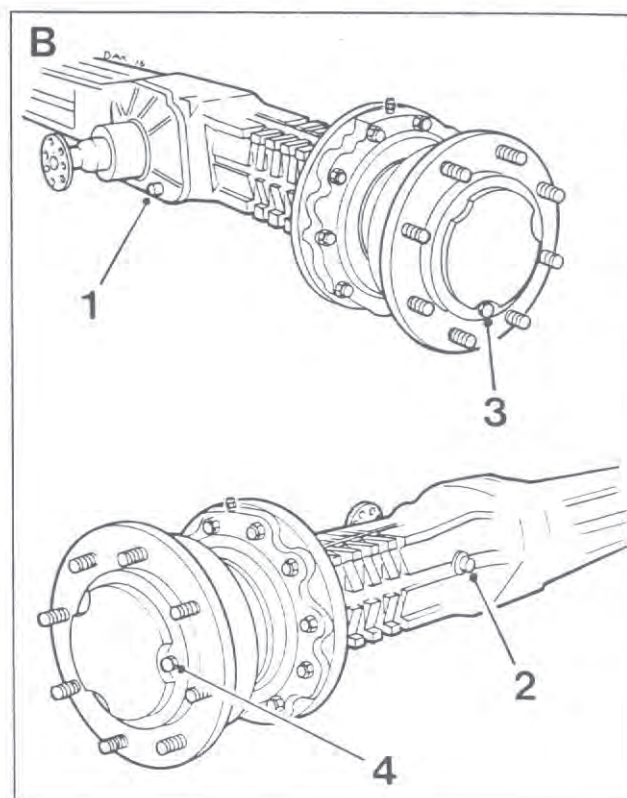

Extra Maintenance

Dirty Working Conditions

Increase the frequency of all maintenance during extremes of dirt, vegetable waste, heat and cold, especially those relating to clean air, cooling efficiency, lubrication and machine cleanliness.

Laying-up Protection

When a machine is to remain idle, remove the battery to the workshop. Seal all openings: air intake, exhaust, breathers. Grease bright parts and protect rubber components from direct sunlight. Fill the fuel tank. Check the tyre pressures and exhaust any pressure from the hydraulic system.

HYDRAULIC SYSTEM

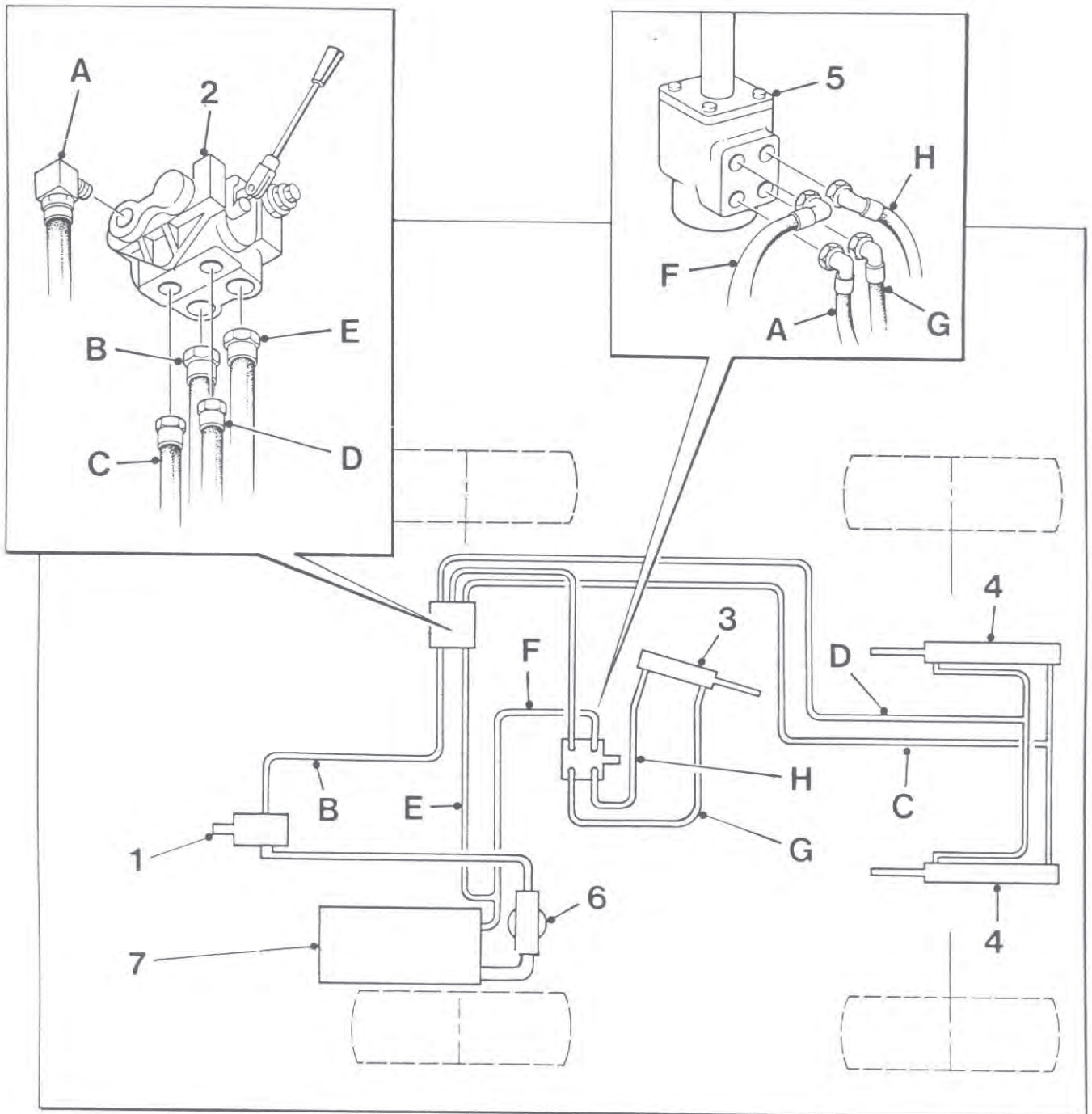

COMPONENTS

- 1 Pump
- 2 Control valve
- 3 Steer ram
- 4 Tipping rams
- 5 Steer unit
- 6 Filter
- 7 Tank

HOSES

- A Control valve to steer valve
- B Control valve to pump
- C Control valve to tipping ram (full bore)
- D Control valve to tipping ram (annulus)
- E Control valve to tank
- F Steer unit to tank
- G Steer unit to steer ram (annulus)
- H Steer unit to steer ram (full bore)

Hydraulic System

The single hydraulic pump provides power for both the skip operation and steering.

The main hydraulic valve splits the pump output into two circuits with controlled rate priority flow to steering circuit.

If the hydraulic system fails to operate completely, or does so extremely slowly, carry out the following procedure.

- A** Check that the hydraulic tank is full of oil to the correct level on the dipstick.
- B** Check that the suction filter element has been regularly changed in accordance with the maintenance schedule. If not, change the filter element.
- C** Check that the hydraulic pressures are correct:

Tip Circuit

- a** Fit a 2000 lb/in² gauge into the hydraulic system at the base of the skip ram.
- b** Operate control lever to tip skip and check that pressure reading on gauge is 1750 lb/in² when ram is fully extended and relief valve is 'blowing'.

Steering Circuit

- a** Fit a 2000 lb/in² gauge into the hydraulic system at the base of the steering ram.
- b** Turn steering wheel to 'full lock' and check that the reading on the gauge is 1750 lb/in²

If none of these procedures correct the fault contact your Distributor.

Periodically check the hose between the pump and the tank to ensure it is not deformed. Any deformation in the hose may result in a restricted flow of fluid and damage to the pump.

BRAKING SYSTEM

Brake System

The brake system is designed to require the minimum of maintenance, and no defects should normally occur.

If air is present in the system, it will be indicated by sluggish response and by spongy action of the brake pedal.

Brake system for machines built before May 1989

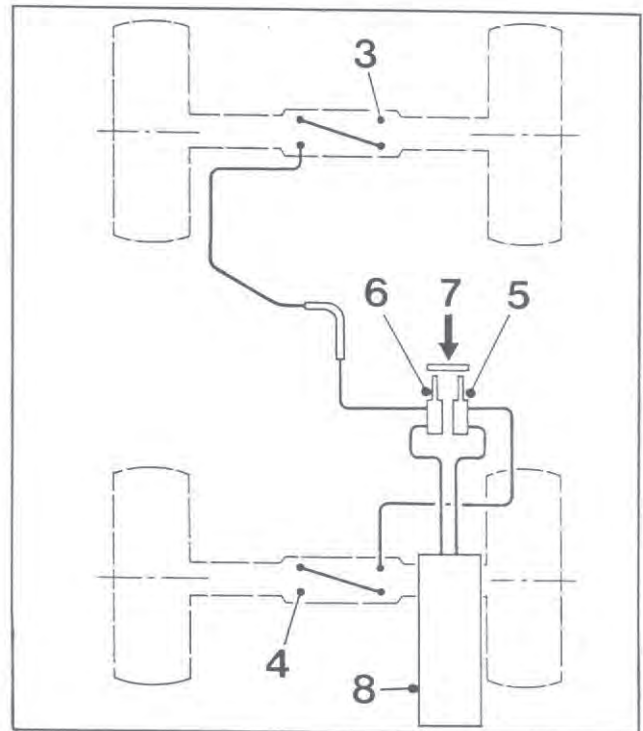

Brake system for machines built after May 1989

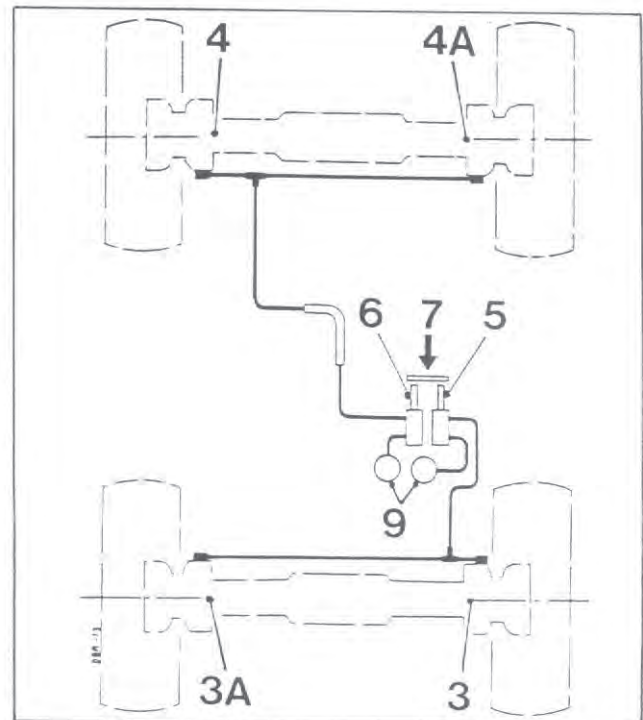

- 3, 3A, 4 & 4A Bleed screws
- 5 Master cylinder (rear axle)
- 6 Master cylinder (front axle)
- 7 Dual brake linkage
- 8 Hydraulic tank
- 9 Brake oil reservoirs

To bleed the system, proceed as follows:

A Check that all connections are tight and the bleed screws are closed.

B Check that there is sufficient oil in:
Machines built before May 1989: main hydraulic tank (8).
Machines built after May 1989: brake reservoirs (9).

WARNING Do not allow the reservoirs to empty during the bleeding procedure.



C Attach bleeder tube (1) to the first bleed screw (3), and immerse the other end of the tube in a small quantity of hydraulic oil contained in a glass jar (2). Slacken bleed screw and depress pedal to its full extent. Hold pedal down and tighten bleed screw. Release pedal and wait 5 - 10 seconds. Slacken bleed screw and repeat the process until oil pumped into the jar contains no air bubbles. Hold down pedal and close bleed screw. Remove bleeder tube and release pedal.

D Lock the bleed screw.

E Repeat procedure for bleed screws (3A, 4 & 4A).

F Top up brake reservoirs (9).

G Apply normal working load on brake pedal for two or three minutes and examine the entire system for leaks.

NOTE: Always ensure that free play of 1 to 2mm exists between the master cylinder push rods and the pistons when the brake pedal is released. Unless the pistons in both master cylinders are allowed to fully return, brake pressure will build up and the brakes will remain on.

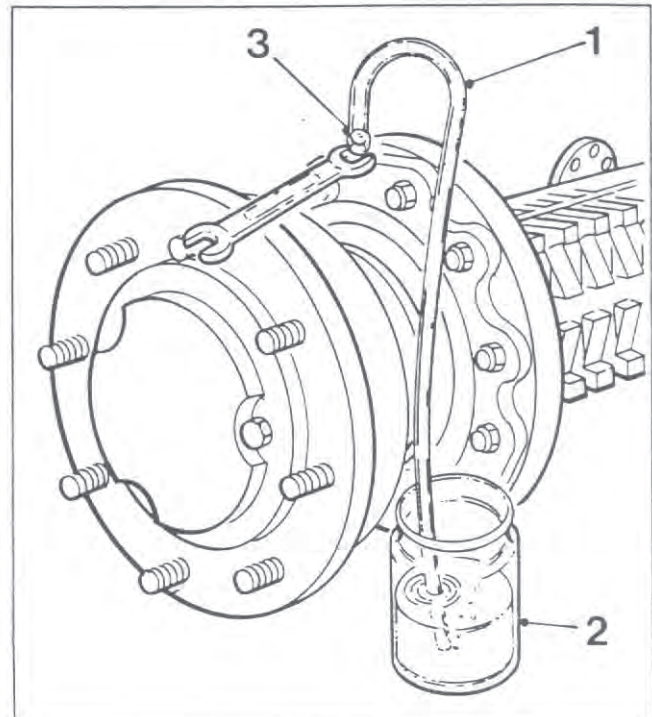

SPECIFICATIONS**Front & rear axles**

Heavy duty double reduction drive axles.

Brakes

Hydraulic dual circuit safety system; operating oil immersed, disc brakes.

Hydraulics

Open circuit system. Spin-on suction cartridge.

Gear type pump: To machine serial number AG01055 4 gall/min (19 l/min)
at 1000 rev/min
From machine serial number AG01056 5.75 gall/min (26 l/min)
at 1000 rev/min

Sectional control valve with pressure relief valve and priority flow valve for steering.

Load capacities**4C4000**

Payload	4000kg	(8820 lb)
Liquid level	1249 litres	(44 ft ³)
Struck	1906 litres	(67 ft ³)
Heaped	2468 litres	(87 ft ³)

4C5000

Payload	5000kg	(11025 lb)
Liquid level	1305 litres	(46 ft ³)
Struck	2150 litres	(76 ft ³)
Heaped	2850 litres	(101 ft ³)

Machine Weight

4C4000	2810kg	(6196 lb)
4C5000	3200kg	(7056 lb)

Engine:

See "Engine Operation Manual "

LUBRICANTS & FLUIDS

Engine lub. oil	<i>See Engine Operation Manual</i>	
Hydraulic transmission	Shell Donax TM	M2C-41B
Gearbox	Esso GX85W-90	AP1GL5/MIL-L-2105C
Transfer gearbox	Shell Donax TM	M2C-41B
Axles (Machines built before May 1989):	Esso Torque Fluid 62	M2C-86B
Axles (Machines built from May 1989):		
Differential & brake casing	Esso Torque Fluid 62	M2C-86B
Hubs	Esso GX85W-90	AP1GL5/MIL-L-2105C
Hydraulic system	Esso Univis N46	ISO 46 Mineral
General grease	Esso Beacon grease	MP/L2
Brake system	Esso Univis N46	ISO 46 Mineral

CAPACITIES, FLUID

Torque converter system	7.26 litres	(12.8 pints)
Gearbox	3.92 litres	(7.0 pints)
Transfer case	2.40 litres	(4.3 pints)
Axles (Machines built before April 1989):		
Each axle	6.25 litres	(11.0 pints)
Axles (Machines built after April 1989):		
Differential & brake casing	7.00 litres	(12.3 pints)
Hubs - each hub	1.00 litre	(1.8 pints)
Hydraulic system (tank capacity)	55.01 litres	(12.1 galls)
Fuel oil (tank capacity)	55.01 litres	(12.1 galls)
Brake system	0.60 litres	(1.0 pints)
Engine Oil	<i>See "Engine Operation Manual"</i>	

ADJUSTMENTS

Wheel nut tightening torque		
Machines built before May 1989	270Nm	(200 lbf ft)
Machines built from May 1989	300Nm	(220 lbf ft)
Engine adjustments	<i>See "Engine Operation Manual"</i>	

PRESSURES

Tyres	front	3.45bar	(50 lbf/in ²)
	rear	3.45bar	(50 lbf/in ²)
Hydraulic system	main relief valve	120bar	(1750 lb/in ²)
Fuel injectors	<i>See "Engine Operation Manual"</i>		

DIMENSIONS

A Overall Length	4.11m	(13ft 6in)
B Overall Width, 4C4000	2.14m	(7ft 0.5in)
B Overall Width, 4C5000	2.20m	(7ft 2.5in)
C Overall Height	1.95m	(6ft 5in)
D Loading Height	1.35m	(4ft 5in)
E Discharge Height	0.65m	(2ft 1.5in)
F Wheelbase	2.19m	(7ft 2in)
G Ground Clearance	0.32m	(1ft 0.5in)
H Forward Discharge Distance	0.40m	(1ft 4in)

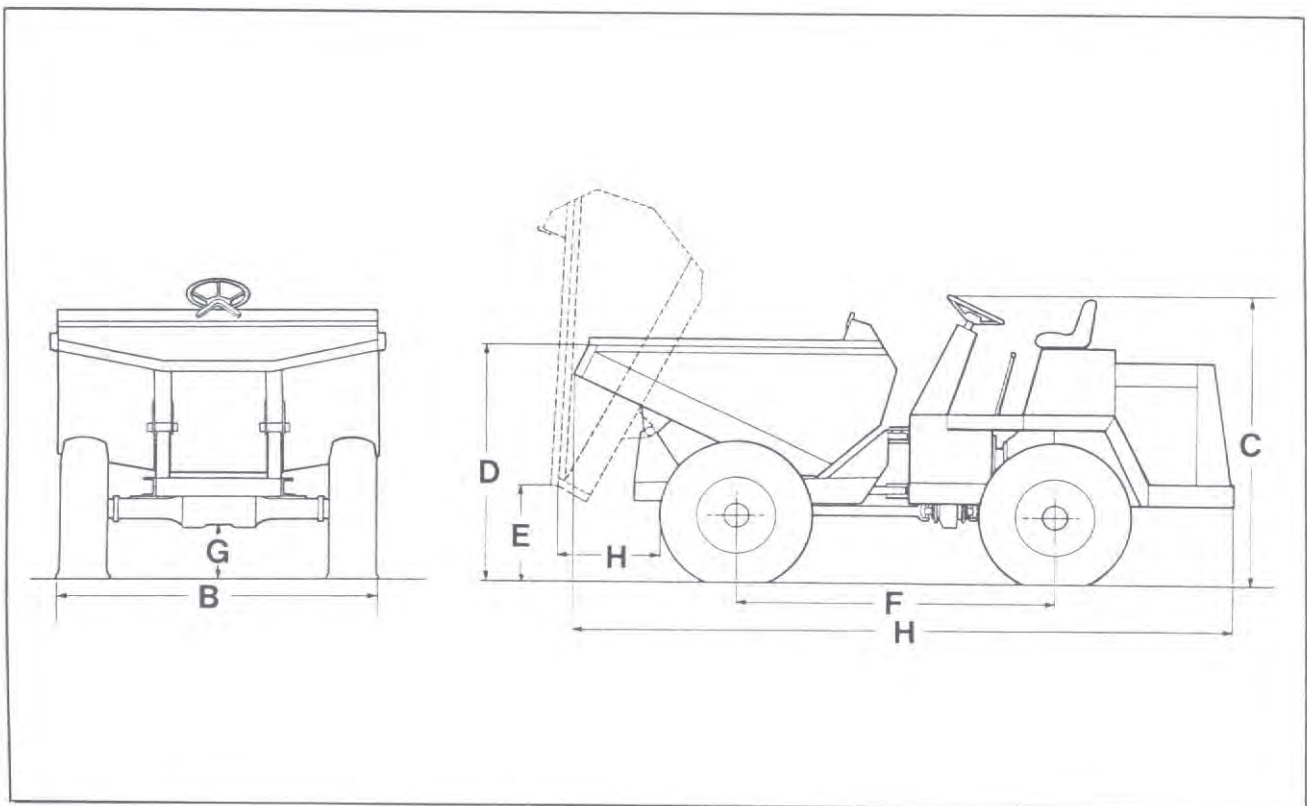

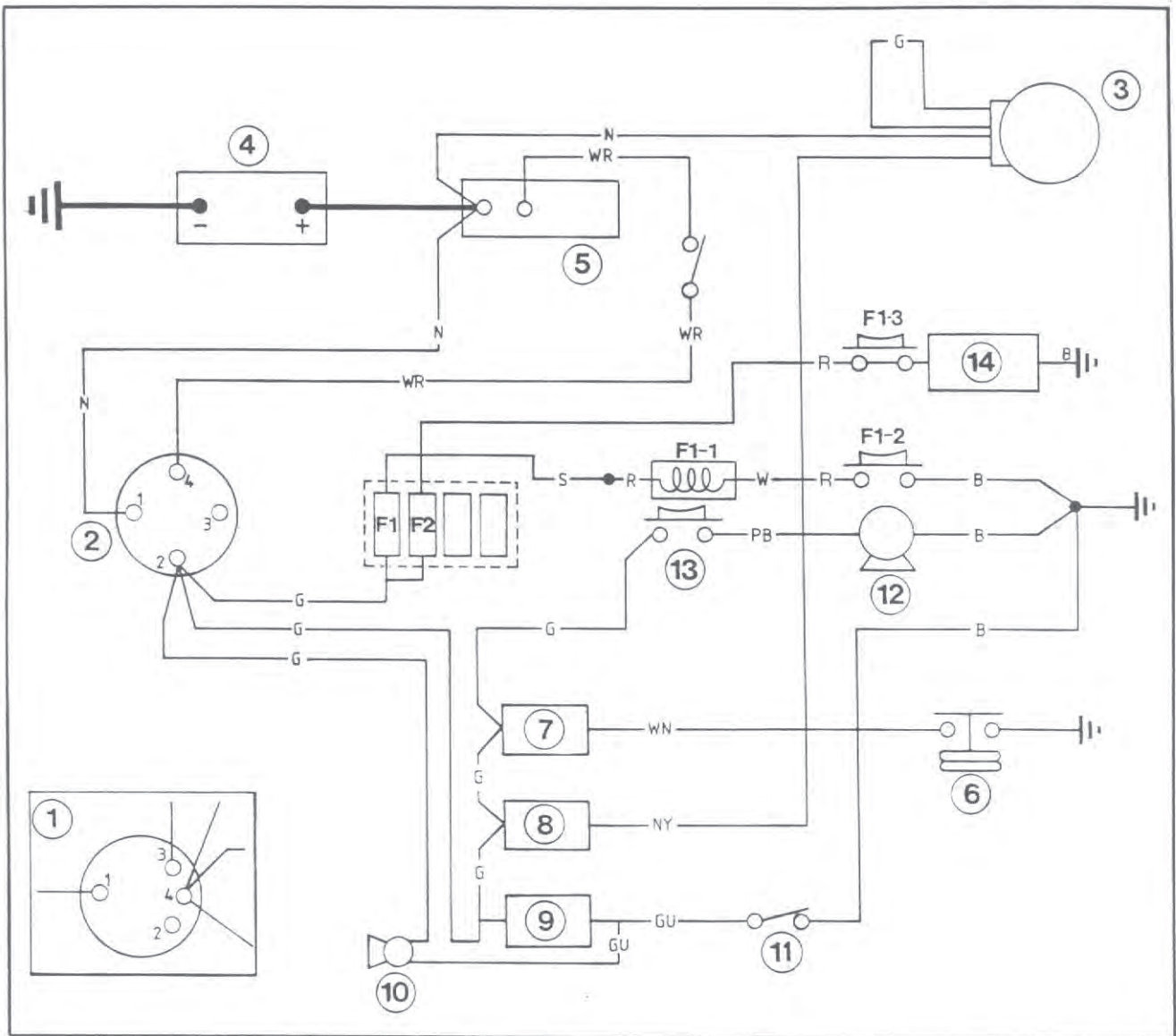

- 1 Key start switch (up to machine serial number AE01018)
- 2 Key start switch (from machine serial number AE01019)
- 3 Alternator
- 4 Battery
- 5 Engine starter motor
- 6 Oil pressure switch
- 7 Oil pressure warning light
- 8 Battery charging light
- 9 Belt tension, warning light
- 10 Belt tension, audible warning
- 11 Belt tension, switch
- 12 Horn
- 13 Horn switch
- 14 Parking brake warning light
- F1 Fuse
- F2 Fuse

- F1-1 Transmission disconnect solenoid
- F1-2 Transmission disconnect switch
- F1-3 Parking brake switch

COLOUR CODES	
N	BROWN
W	WHITE
R	RED
U	BLUE
P	PURPLE
Y	YELLOW
G	GREEN
S	SLATE
B	BLACK

DUMPER
4C4000
4C5000

PARTS

WINGET

1

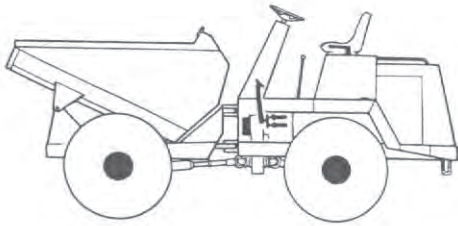

6

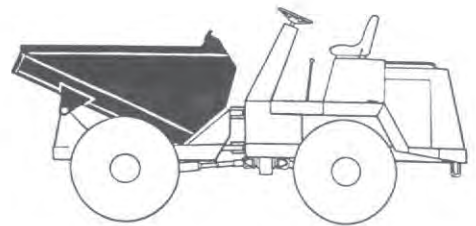

2

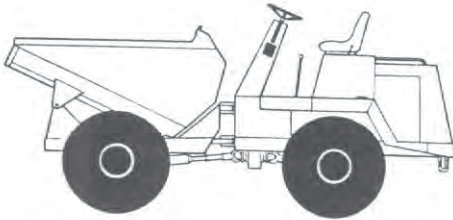

7

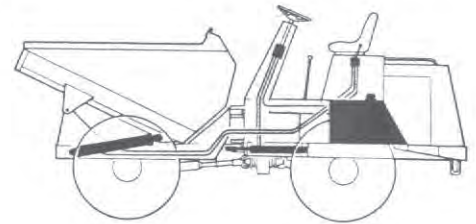

3

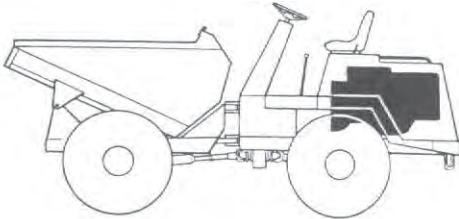

8

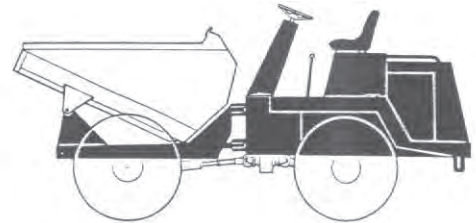

4

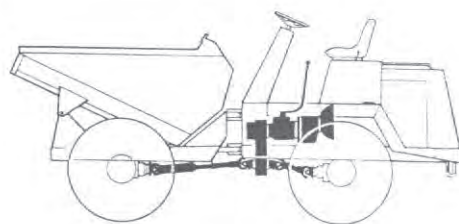

9



5

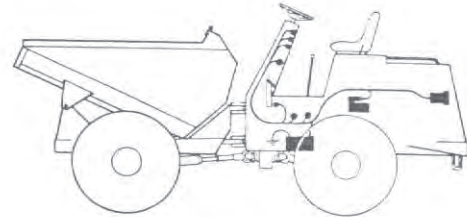

CONTENTS

- 1 BRAKES**
- 2 AXLES & STEERING**
- 3 ENGINE**
- 4 TRANSMISSION**
- 5 ELECTRICS**
- 6 SKIP**
- 7 HYDRAULICS**
- 8 FRAME & PANELS**
- 9 MISCELLANEOUS**

BRAKES

- 1 - A - 1 BRAKE HYDRAULIC CIRCUIT, 4C4000
to machine serial number BC01185
- 1 - A - 2 MASTER CYLINDER
- 1 - A - 3 BRAKE PEDAL, to machine serial number
BC01185
- 1 - A - 4 BRAKE PEDAL, from machine serial number
BC01186
- 1 - A - 5 BRAKE HYDRAULIC CIRCUIT, 4C4000 & 4C5000
from machine serial number BC01186
- 1 - A - 6 BRAKE FLUID RESERVOIRS

- 1 - B - 1 PARKING BRAKE, transfer gearbox
- 1 - B - 2 LEVER, PARKING BRAKE

4C4000 Dumper, to machine serial number BC01185

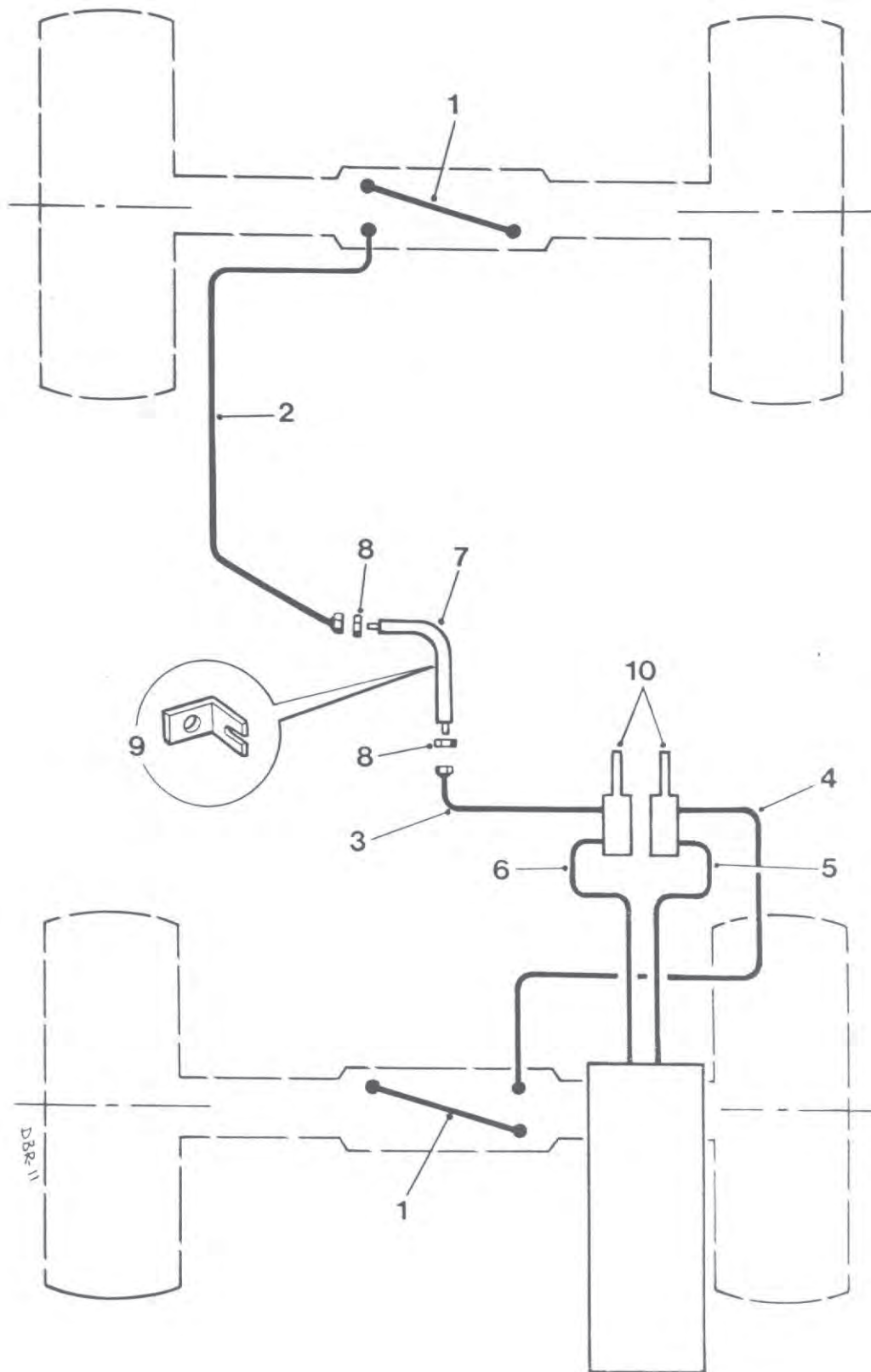

BRAKE HYDRAULIC CIRCUIT

1 - A - 1

Item	Part no	Serial no	Description	Qty
1	10968A02	AA01000/ BC01185	PIPE	2
2	V2000419		PIPE, front	1
3	V2000302		PIPE	1
4	V2000305		PIPE, rear	1
5	V2000304		PIPE	1
6	V2000305		PIPE	1
7	10517A02		HOSE	1
8	10582A01		NUT, locking	2
9	V2000325		BRACKET, hose	1
10	—		MASTER CYLINDER (see page 1 - A - 2)	2

4C4000 & 4C5000 Dumper

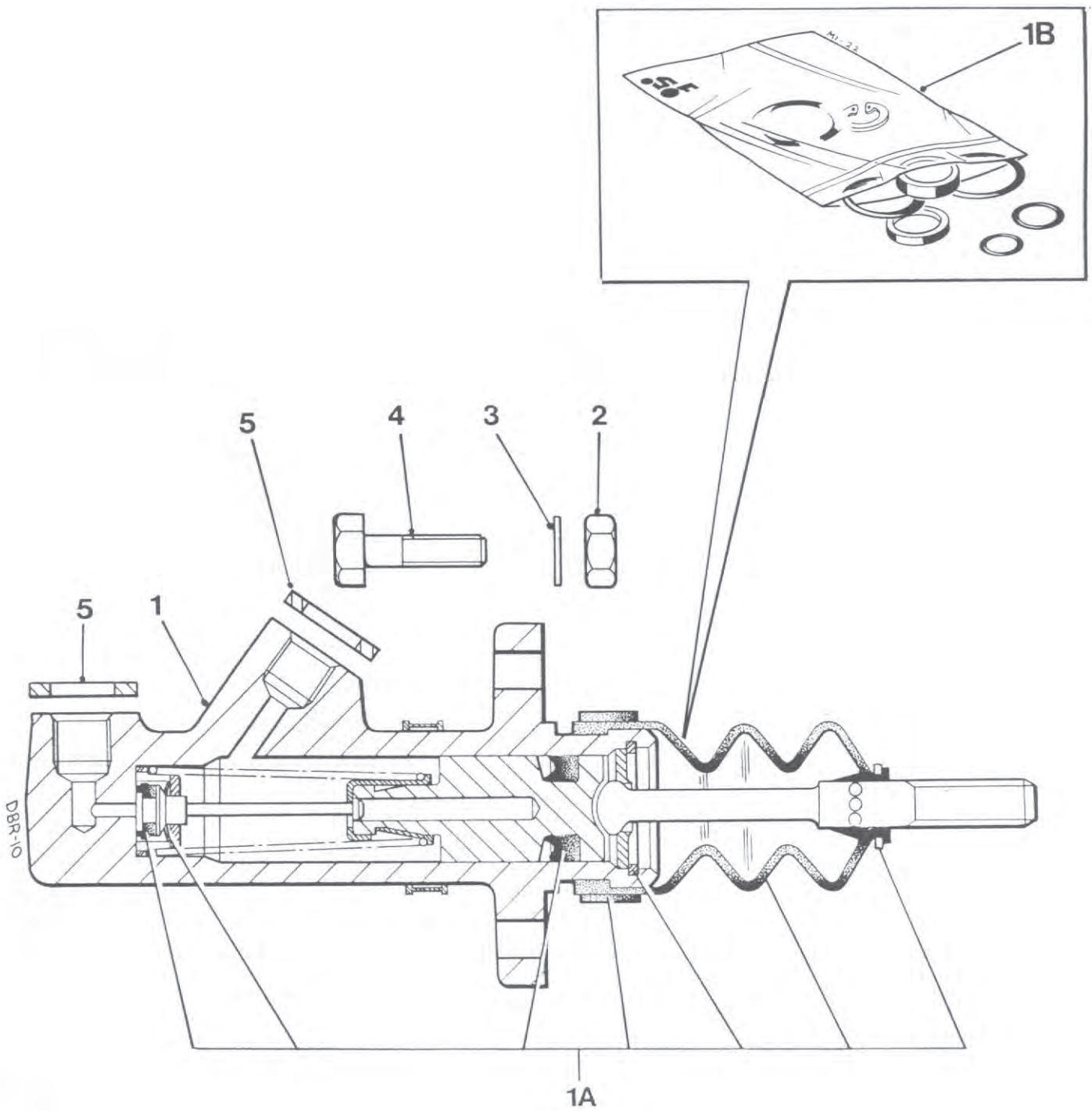

MASTER CYLINDER, oil immersed brakes**1 - A - 2**

Item	Part no	Serial no	Description	Qty
1	20102A02	AA01000/ BC01185	MASTER CYLINDER	2
1A	10570A01	AA01000/ BC01185	KIT, repair	1
1	V2000977	BC01196/	MASTER CYLINDER	2
1B	V600117	BC01186/	KIT, seals	1
2	61S03	AA01000/	NUT, self locking	4
3	267S05	AA01000/	WASHER, flat	4
4	8S03B	AA01000/	SCREW, set	4
5	116S16	AA01000/	WASHER, copper	4

4C4000 & 4C5000 Dumper

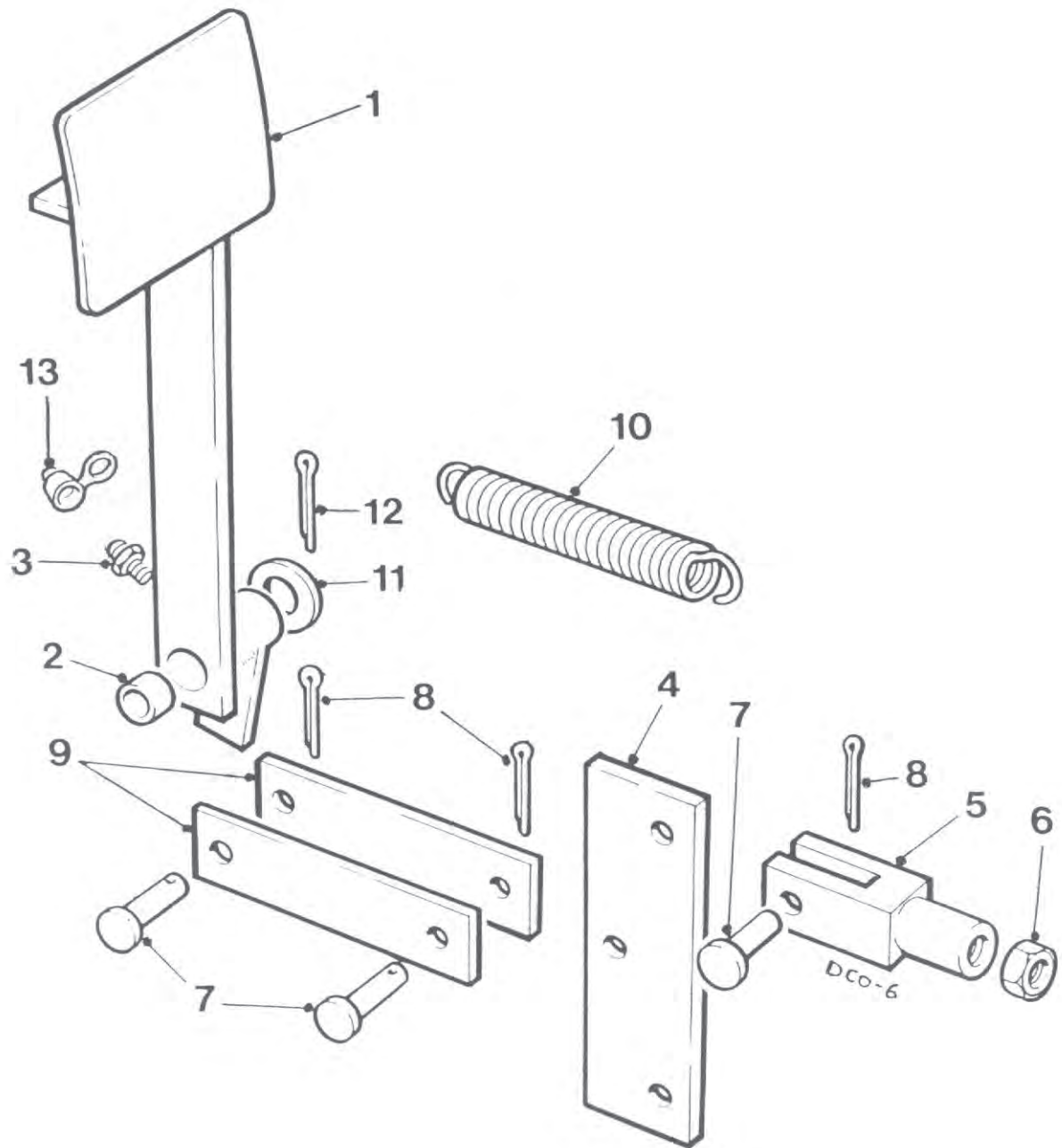

BRAKE PEDAL**1 - A - 3**

Item	Part no	Serial no	Description	Qty
1	V2000290	AA01000/ BC01185	PEDAL, brake	1
2	43S02	AA01000/ BC01185	BUSH	2
3	131S01	AA01000/ BC01185	NIPPLE, grease	1
4	20117A06	AA01000/ BC01185	BEAM, compensator	1
5	10454A02	AA01000/ BC01185	CLEVIS, master cylinder	2
6	95S03	AA01000/ BC01185	NUT, locking	2
7	10650A18	AA01000/ BC01185	PIN, clevis	4
8	44S02C	AA01000/ BC01185	PIN, split	4
9	V2000289	AA01000/ BC01185	LINK, pedal	2
10	C173B	AA01000/ BC01185	SPRING	1
11	10S17	AA01000/ BC01185	WASHER, flat	2
12	44S04E	AA01000/ BC01185	PIN, split	1
13	176S01	AA01000/ BC01185	CAP, grease nipple	1

4C4000 & 4C5000 Dumper

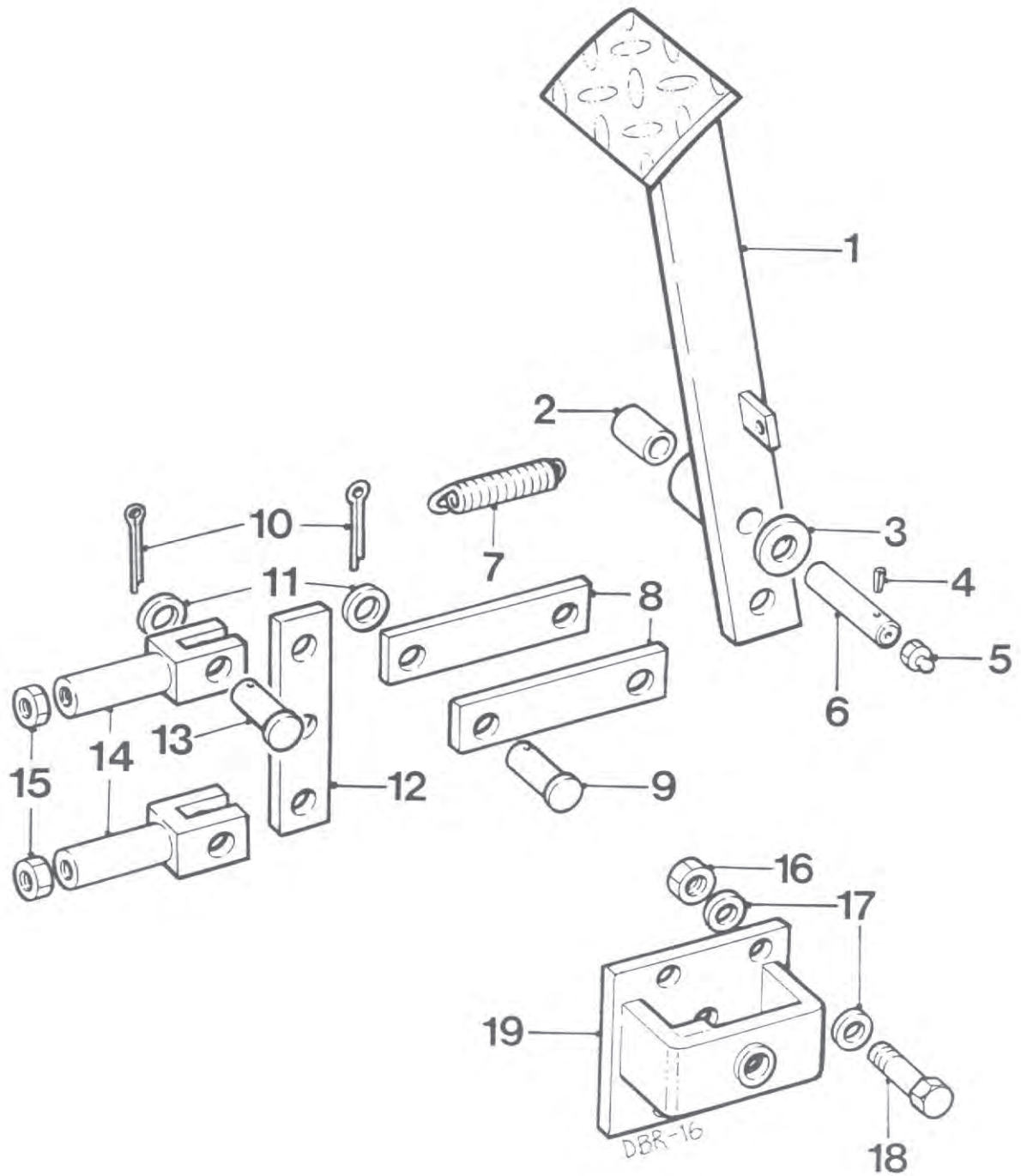

BRAKE PEDAL**1 - A - 4**

Item	Part no	Serial no	Description	Qty
1	V2002372	BC01186/	PEDAL, brake	1
2	43S02	BC01186/	BUSH	1
3	10S39	BC01186/	WASHER, flat	1
4	55S04	BC01186/	PIN, spirol	1
5	131S06	BC01186/	NIPPLE, grease	1
6	V2002376	BC01186/	PIN, pivot	1
7	C173B	BC01186/	SPRING	1
8	V2002375	BC01186/	LINK	2
9	10650A18	BC01186/	PIN, clevis	2
10	44S02C	BC01186/	PIN, split	4
11	10S03	BC01186/	WASHER, flat	6
12	V2002374	BC01186/	LINK	1
13	10650A19	BC01186/	PIN, clevis	2
14	V2002377	BC01189/	CLEVIS	2
15	56S04	BC01186/	NUT	2
16	7S03	BC01186/	NUT	4
17	12S03	BC01186/	WASHER, flat	8
18	8S03B	BC01186/	BOLT	4
19	V2002373	BC01186/	BRACKET	1

4C4000 & 4C5000 Dumper, from machine serial number BC01185

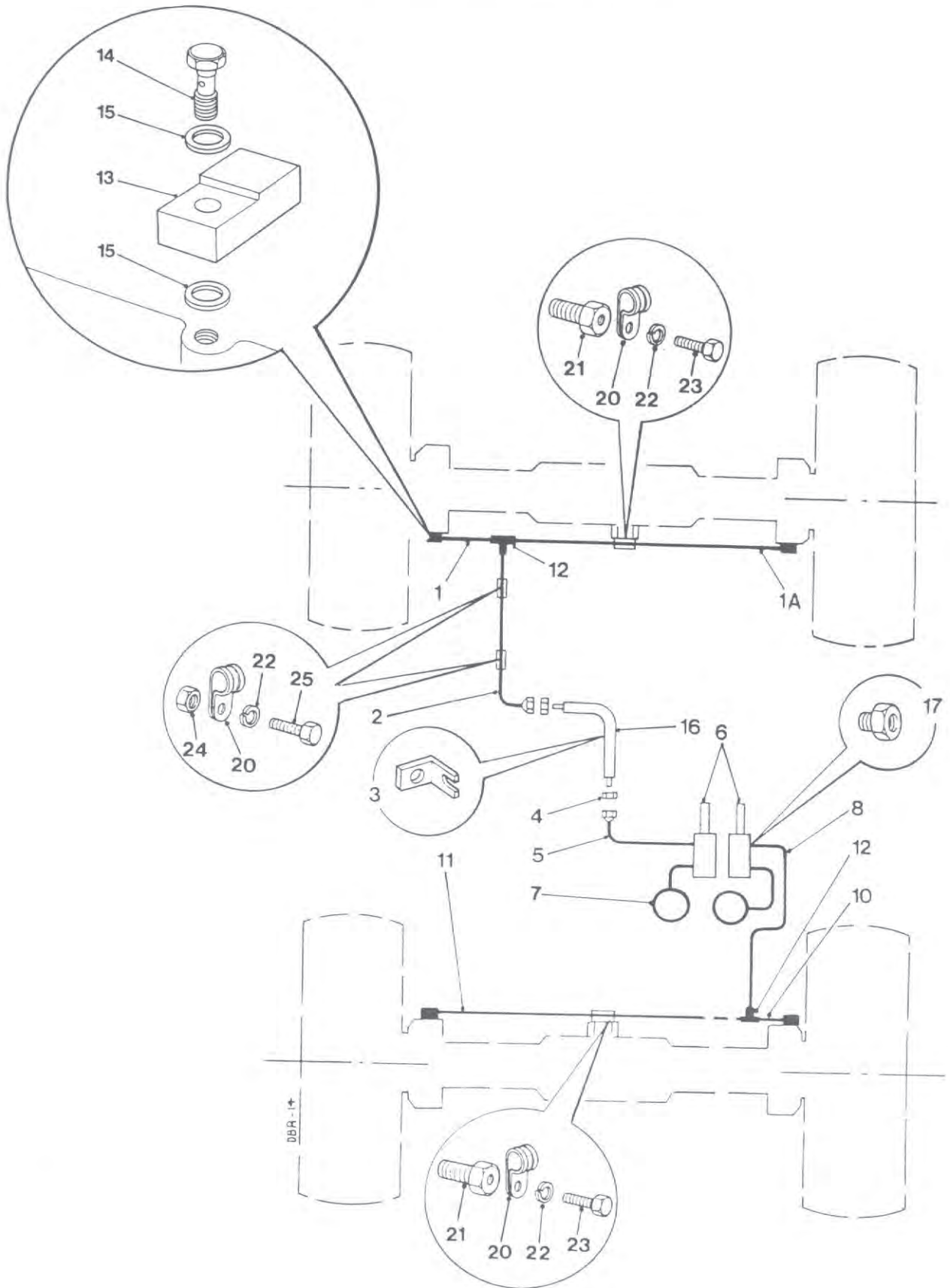

BRAKE HYDRAULIC CIRCUIT

1 - A - 5

Item	Part no	Serial no	Description	Qty
1	V2001631	BC01186/ BC01194	PIPE	1
1A	V2001631	BC01186/ BC01194	PIPE	1
1	V2002183	BC01195/	PIPE	1
1A	V2001632	BC01195/	PIPE	1
2	V2001634	BC01186/ BC01194	PIPE	1
2	V2002180	BC01195/	PIPE	1
3	V2000325	BC01195/	BRACKET	1
4	10582A01	BC01195/	NUT, locking	2
5	V2000302	BC01195/	PIPE	1
6	-	BC01195/	MASTER CYLINDER (see page 1 - A - 2)	2
7	-	BC01186/	RESERVOIR (see page 1 - A - 6)	2
8	V2000305	BC01186/ BC01194	PIPE	1
8	V2002182	BC01195/	PIPE	1
10	V2001633	BC01186/ BC01194	PIPE	1
10	V2002183	BC01195/	PIPE	1
11	V2001632	BC01195/	PIPE	1
12	152S03	BC01195/	ADAPTOR, tee	2
13	V2001630	BC01195/	BANJO	4
14	V2003241	BC01195/	BOLT, banjo	4
15	V2003242	BC01195/	WASHER, copper	8
16	10517A02	BC01195/	HOSE	1
17	V2001626	BC01195/	ADAPTOR	4
20	V2002134	BC01195/	CLIP	4
21	V2002125	BC01195/	SCREW	4
22	17S02	BC01195/	WASHER, spring	4
23	11S01A	BC01195/	SCREW	2
24	7S01	BC01195/	NUT	2
25	11S01B	BC01195/	SCREW	2

4C4000 & 4C5000 Dumper, from machine serial number BC01185

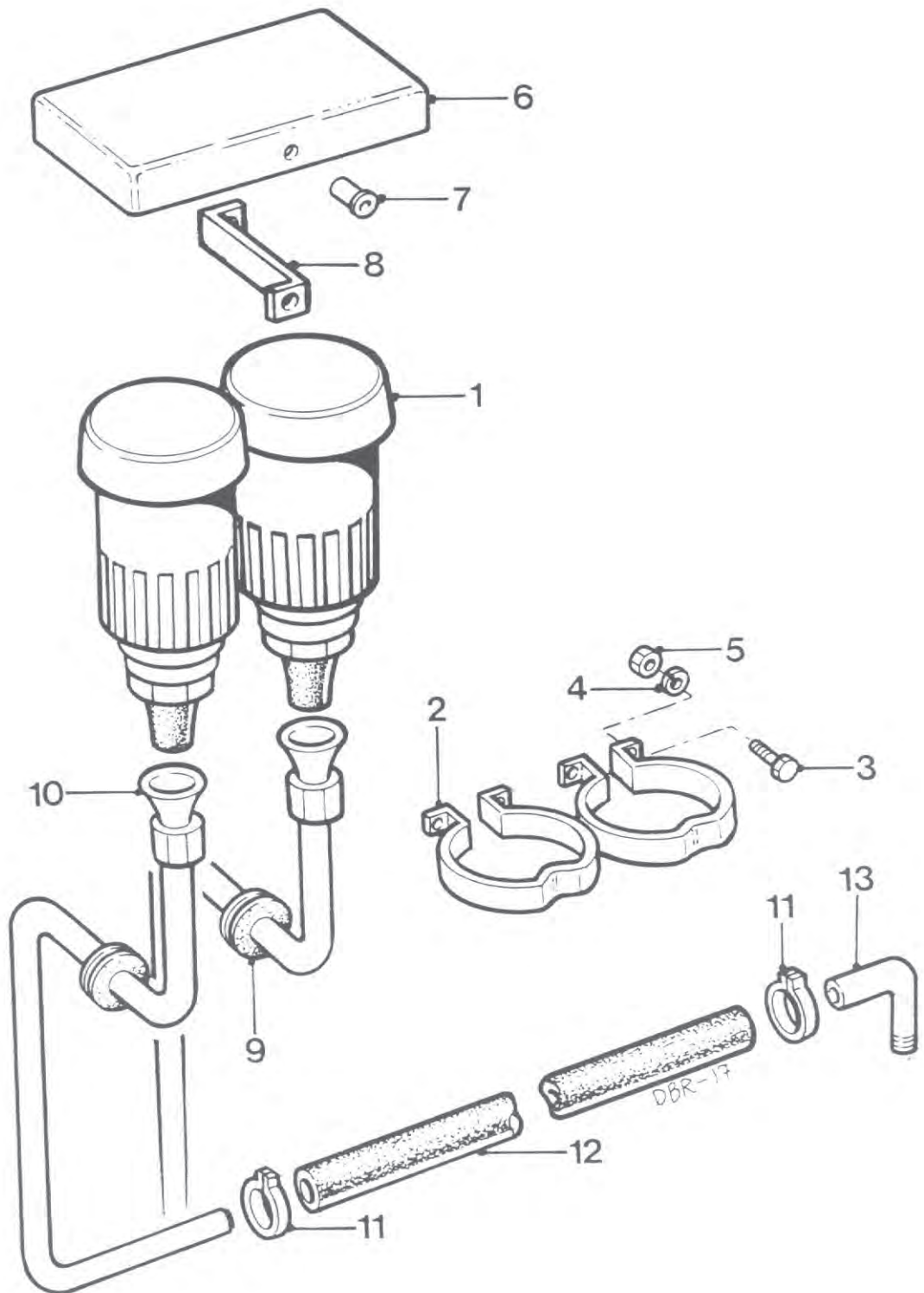

BRAKE RESERVOIRS

1 - A - 6

Item	Part no	Serial no	Description	Qty
1	10659A02	BC01186/	RESERVOIR	2
2	10659A0102	BC01186/	CLIP, reservoir	2
3	16S06A	BC01186/	SCREW, set	4
4	17S02	BC01186/	WASHER, spring	4
5	7S01	BC01186/	NUT	4
6	V2002380	BC01186/	COVER	1
7	V2003179	BC01186/	RIVET, pop	6
8	V2002381	BC01186/	SUPPORT	1
9	V2003252	BC01186/	GROMMET, open	2
10	V2002405	BC01186/	PIPE, brake	2
11	165S04	BC01186/	CLIP, hose	2
12	29S07	BC01186/	HOSE	2
13	10542A01	BC01186/	PIPE, stud	2

4C4000 & 4C5000 Dumper

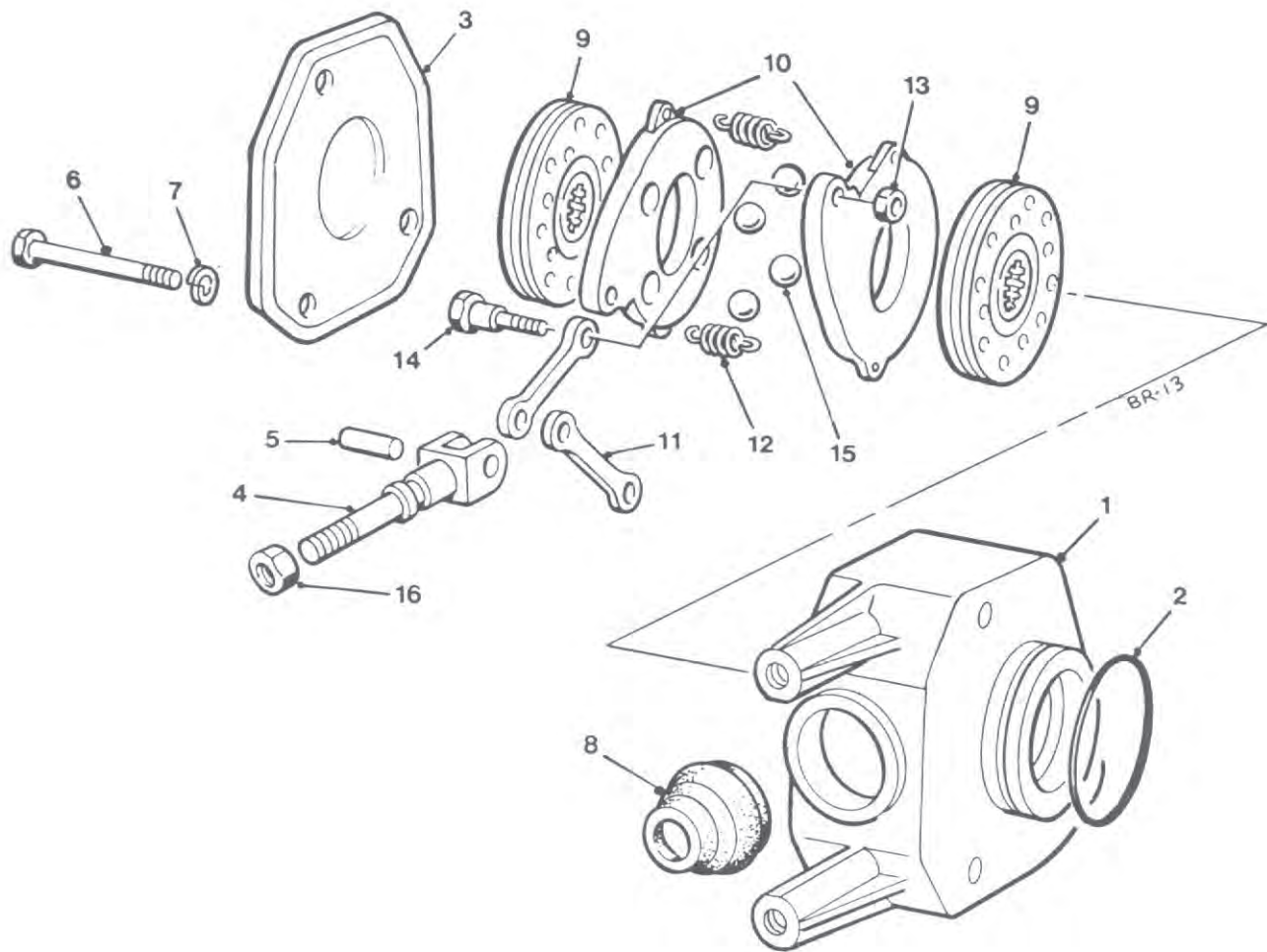

PARKING BRAKE, transfer gearbox

1 - B - 1

Item	Part no	Serial no	Description	Qty
-	-	AA01000/	BRAKE (part of V2000169 assembly)	
1	V600451		HOUSING, brake	1
2	V600437		'O' RING	1
3	V600446		COVER	1
4	V600447		ROD, brake actuating	1
5	V600448		PIN	1
6	8S05P		BOLT	3
7	17S06		WASHER, spring	3
-	V600465		BRAKE, 4" x 2", assembly	1
8	V600467		SEAL, dust	1
9	V600466		DISC, brake	2
-	V600468		BRAKE MECHANISM, assembly	1
10	-		BRAKE MECHANISM (order assembly)	
11	V600469		LINK	2
12	V600470		SPRING	2
13	V600471		NUT, locking	2
14	V600472		PIN, pivot	2
15	V600473		BALL	4
-	V600474		KIT, lining, for V600466	1
16	V2003220		NUT, domed	1

4C4000 & 4C5000 Dumper

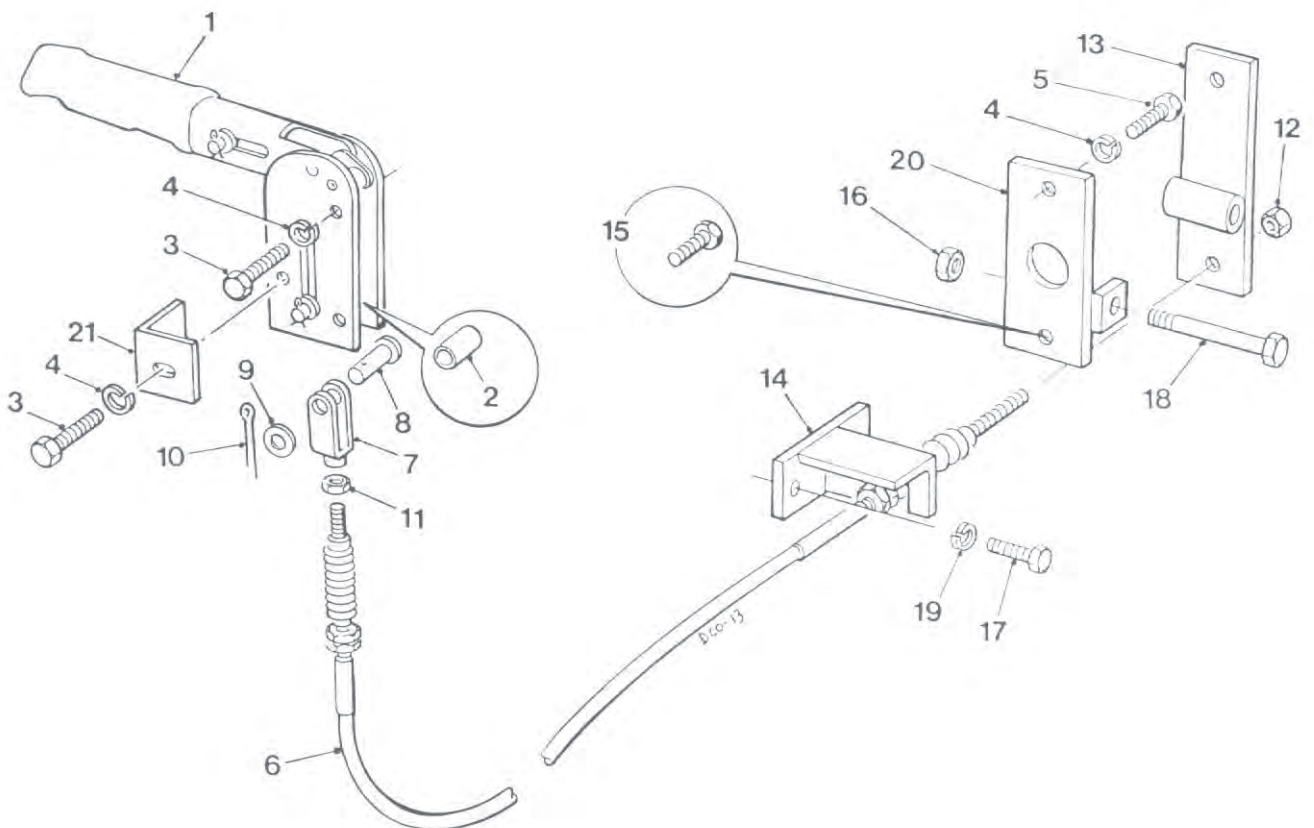
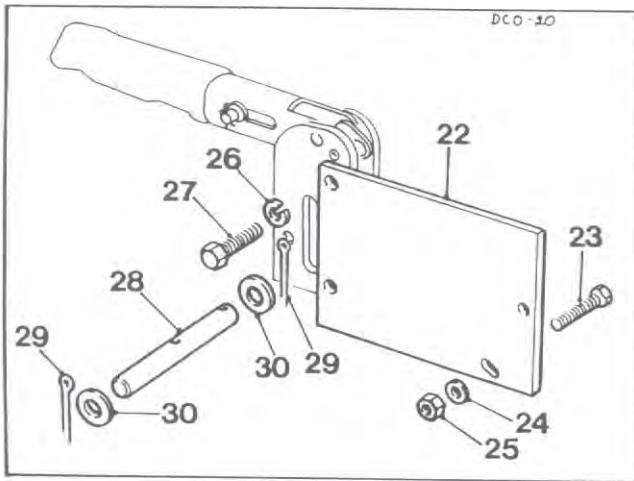

LEVER, PARKING BRAKE

1 - B - 2

Item	Part no	Serial no	Description	Qty
1	V2003170	AA01000/	PARKING BRAKE	1
2	V2003171	AA01000/	SPACER	3
3	8S04F	AA01000/	BOLT	3
4	17S05	AA01000/	WASHER, spring	4
5	11S04B	AA01000/	SCREW, set	1
6	V2003190	AA01000/	CABLE, parking brake	1
7	V2003175	AA01000/	CLEVIS	1
8	V600493	AA01000/	PIN, clevis	1
9	267S05	AA01000/	WASHER, flat	1
10	44S02C	AA01000/	PIN, split	1
11	9S02	AA01000/	NUT, locking	1
12	V2003219	AA01000/	NUT, domed	1
13	V2000007	AA01000/	LEVER, parking brake	1
14	V2000009	AA01000/	ANCHOR, cable	1
15	52S04D	AA01000/	SCREW	1
16	61S05	AA01000/	NUT, binx	1
17	11S03D	AA01000/	SCREW, set	2
18	8S05K	AA01000/	BOLT	1
19	17S04	AA01000/	WASHER, spring	2
20	V2000008	AA01000/	BRACKET, parking brake	1
21	V2001605	BE01198/ AJ01296	BRACKET, switch	1
22	V2001739	AJ01297/	BRACKET, switch	1
23	200S09J	AJ01297/	SCREW, set	2
24	267S03	AJ01297/	WASHER, flat	4
25	202S25	AJ01297/	NUT	2
26	17S05	AJ01297/	WASHER, spring	3
27	8S04F	AJ01297/	BOLT	3
28	V2001740	AJ01297/	PIN	1
29	44S11E	AJ01297/	PIN, split	2
30	267S05	AJ01297/	WASHER, flat	2

AXLES & WHEELS

- 2 - A - 1 AXLE & MOUNTING, 4C4000, to machine serial no. BC01185
- 2 - A - 2 AXLE ARM & HUB, 4C4000, to machine serial no. BC01185
- 2 - A - 3 AXLE CASING, PINION, DIFFERENTIAL & BRAKE, 4C4000, to machine serial no. BC01185

- 2 - B - 1 AXLE MOUNTS, 4C4000 & 4C5000, from machine serial no. BC01186
- 2 - B - 2 AXLES, 4C4000 & 4C5000, from machine serial no. BC01186
- 2 - B - 3 AXLE HOUSING, 4C4000 & 4C5000, from machine serial no. BC01186
- 2 - B - 4 CROWN WHEEL & PINION, 4C4000 & 4C5000, from machine serial no. BC01186
- 2 - B - 5 DIFFERENTIAL, 4C4000 & 4C5000, from machine serial no. BC01186
- 2 - B - 6 WHEEL HUB, 4C4000 & 4C5000, from machine serial no. BC01186
- 2 - B - 7 BRAKES, 4C4000 & 4C5000, from machine serial no. BC01186
- 2 - B - 8 EPICYCLIC REDUCTION GEARS, 4C4000 & 4C5000, from machine serial no. BC01186

- 2 - S - 1 STEERING COLUMN

- 2 - W - 1 WHEELS & TYRES, 4C4000
- 2 - W - 2 WHEELS & TYRES, 4C5000

4C4000 Dumper, to machine serial number BC01185

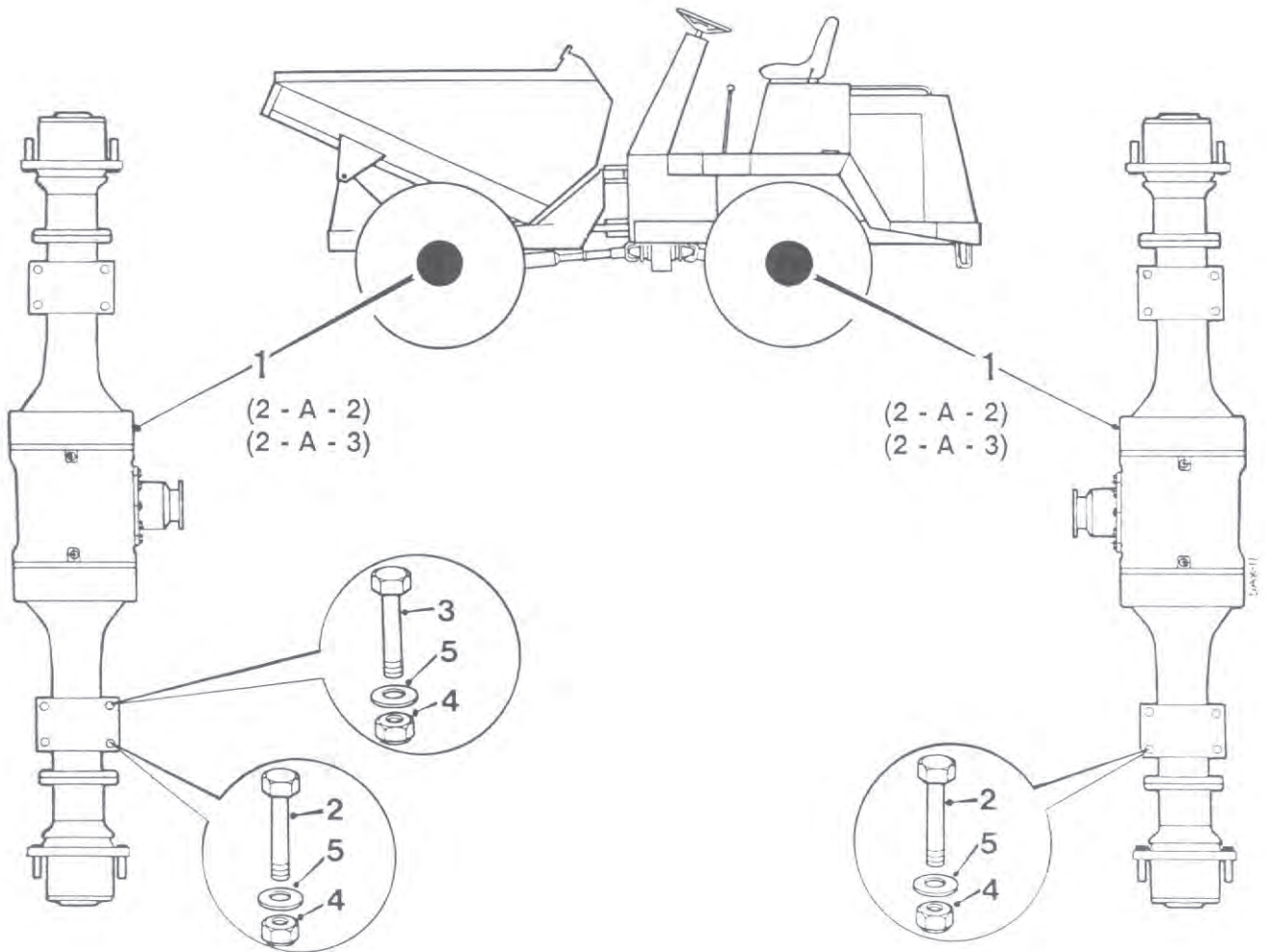

AXLE & MOUNTING

2 - A - 1

Item	Part no	Serial no	Description	Qty
1	V2000001	AA01000/BC01185	AXLE, assembly	2
2	8S06K		BOLT	12
3	8S06M		BOLT (front axle only)	4
4	59S11		NUT, nylon insert	16
5	267S09		WASHER, flat	16

4C4000 Dumper, to machine serial number BC01185

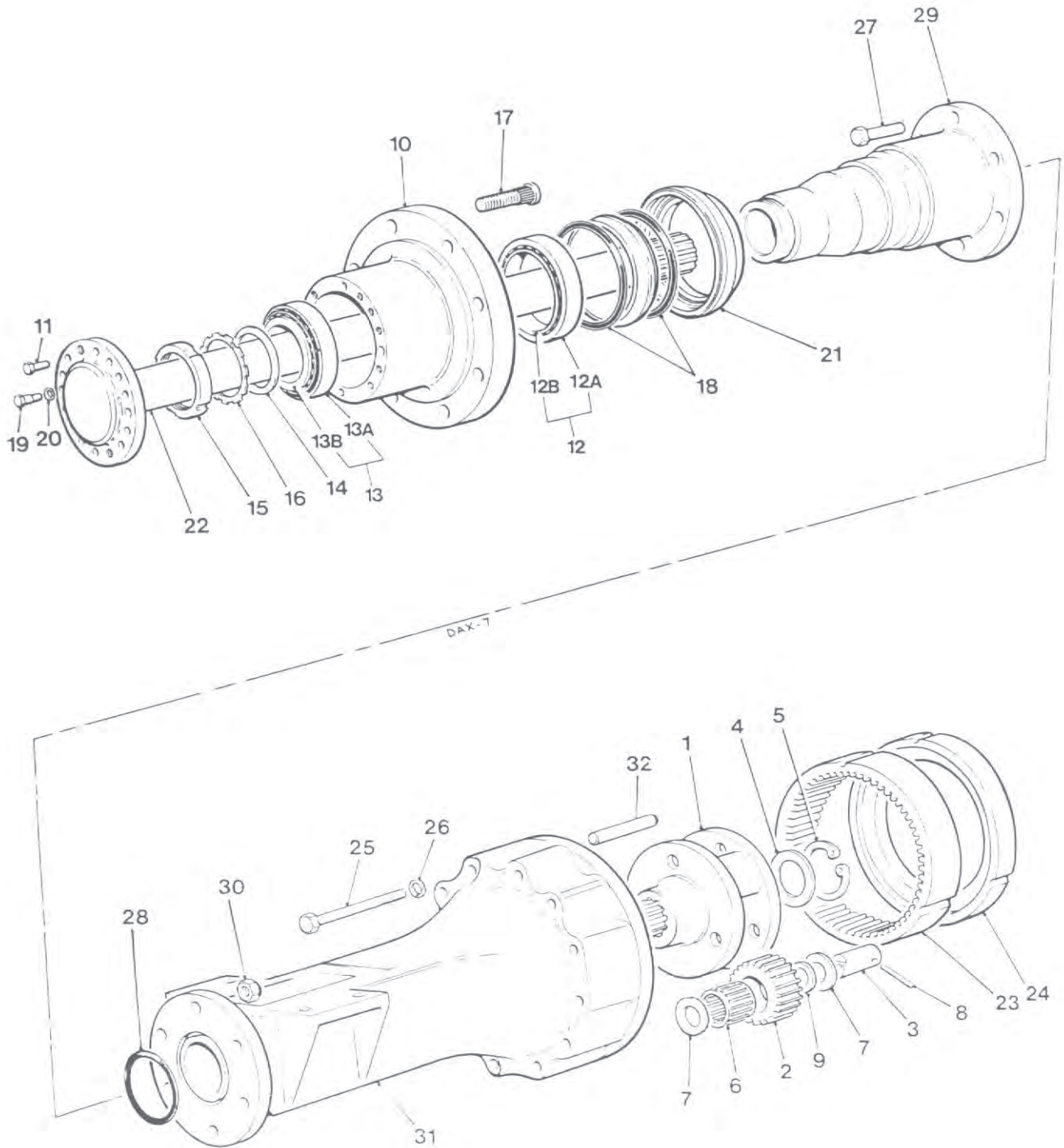

AXLE ARM & HUB

2 - A - 2

Item	Part no	Serial no	Description	Qty
-	-	AA01000/BC01185	CASING & PINION (see page 2 - A - 3)	1
1	V600028		CARRIER, planet	2
2	V600029		GEAR	6
3	V600030		PIN	6
4	V600031		SPACER	2
5	V600032		CIRCLIP	2
6	V600033		BEARING	6
7	30082A0249		WASHER	12
8	30082A0253		PIN	6
9	V600035		SPACER	6
10	V600036		HUB	2
11	30045A0247		SCREW	24
12	V600037		BEARING, assembly	2
12A	30082A0279		CUP, bearing	1
12B	30082A0278		CONE, bearing	1
13	V600038		BEARING, assembly	2
13A	V600161		CUP, bearing	1
13B	V600160		CONE, bearing	1
14	30045A0261		SPACER	2
15	30045A0259		NUT	2
16	30045A0260		WASHER, locking	2
17	30082A0225		STUD	16
18	30045A0257		SEAL	2
19	V600041		SCREW	4
20	17S07		WASHER, spring	4
21	30045A0256		HOUSING, oil seal	4
22	V600043		SHAFT, axle	4
23	V600044		ANNULUS	4
24	V600045		SPACER	4
25	V600046		BOLT	24
26	17S05		WASHER, spring	24
27	V600048		SCREW	12
28	30045A0254		'O' RING	2
29	V600049		AXLE, stub	2
30	30045A0253		NUT	12
31	V600050		ARM, axle	2
32	V600051		PIN	6

4C4000 Dumper, to machine serial number BC01185

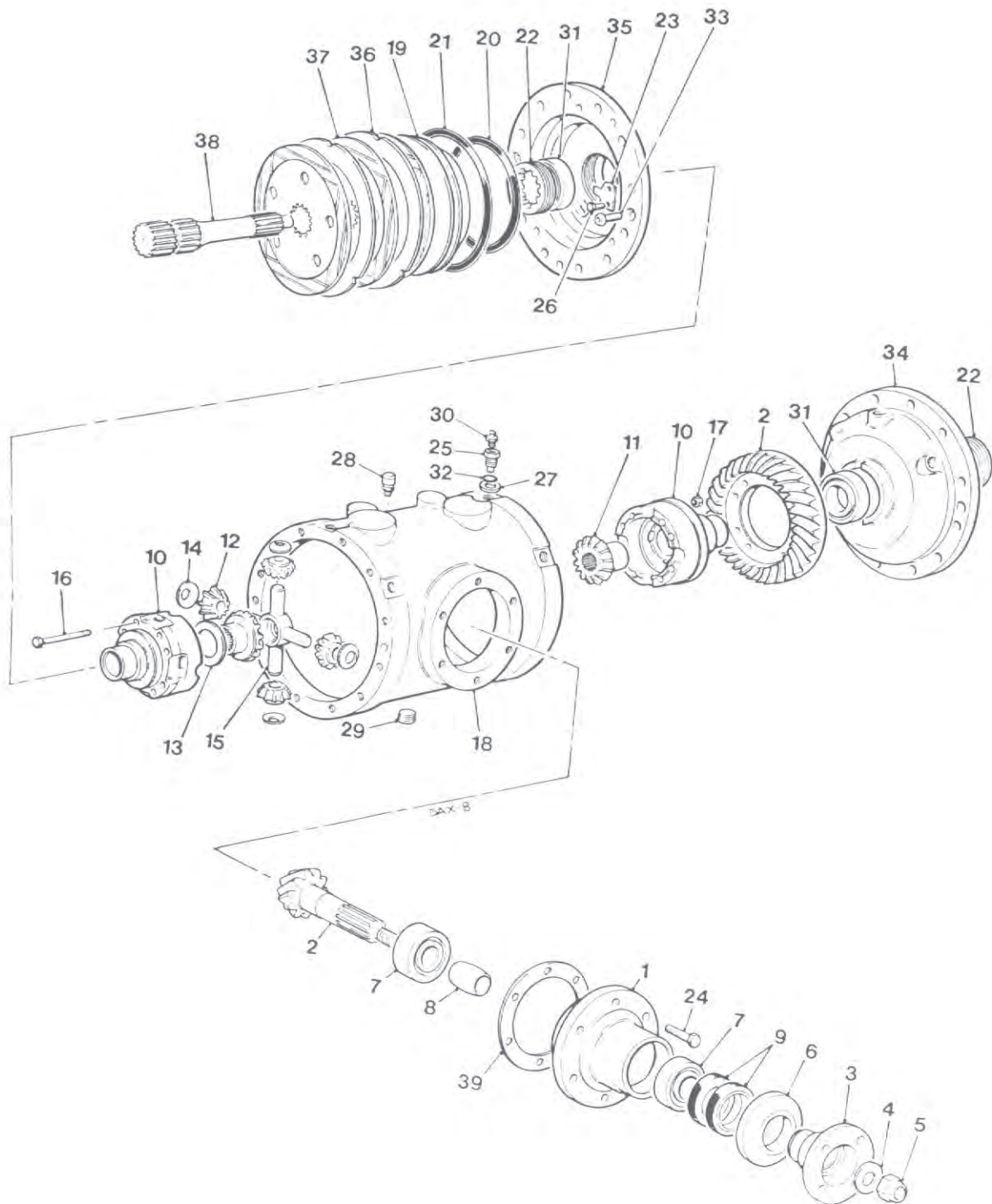

AXLE CASING, PINION, DIFFERENTIAL & BRAKE

2 - A - 3

Item	Part no	Serial no	Description	Qty
-	-	AA01000/BC01185	ARM & HUB (see page 2 - A - 2)	1
1	V601262		COVER, pinion	1
2	V600052		CROWN WHEEL & PINION	1
3	30045A0203		FLANGE, drive	1
4	30045A0204		WASHER, flat	1
5	30045A0205		NUT	1
6	30045A0206		COVER	1
7	30045A0207		BEARING	2
8	30045A0208		SPACER	1
9	30045A0209		SEAL	2
10	30045A0210		CASING, differential, matched pair	1
11	30045A0212		GEAR, side	2
12	30045A0213		GEAR, planet	4
13	30045A0214		WASHER, flat	2
14	30045A0215		WASHER	4
15	30045A0216		SPIDER	1
16	30045A0218		BOLT	8
17	30045A0219		NUT	8
18	V600054		CASING, axle	1
19	30100A0210		PISTON, brake	2
20	30100A0211		SEAL, assembly	2
21	-		SEAL (order assembly)	2
22	30045A0235		NUT	2
23	30082A0261		PLATE	2
24	11S04C		SCREW, set	6
25	V600003		ADAPTOR	4
26	30082A0261		SCREW	4
27	V600004		SEAL, bonded	4
28	30082A0214		BREATHER	1
29	30082A0212		PLUG	2
30	V600005		BLEED SCREW	2
31	V600006		BEARING, assembly	2
-	30045A0266		CUP, bearing	1
-	30045A0267		CONE, bearing	1
32	49S02		'O' RING	4
33	30045A0248		SCREW	4
34	V600008		BRAKE CYLINDER, R.H. front, L.H. rear	1
35	V600009		BRAKE CYLINDER, L.H. front, R.H. rear	1
36	30082A0205		PLATE, brake, fixed	4
37	30082A0206		DISC, brake	4
38	V600010		GEAR, sun	2
39	30082A0211		SHIM 0.05"	AR
39	30082A0210		SHIM 0.075"	AR
39	30082A0209		SHIM 0.25"	AR

4C4000 & 4C5000 Dumper, from machine serial no BC01186

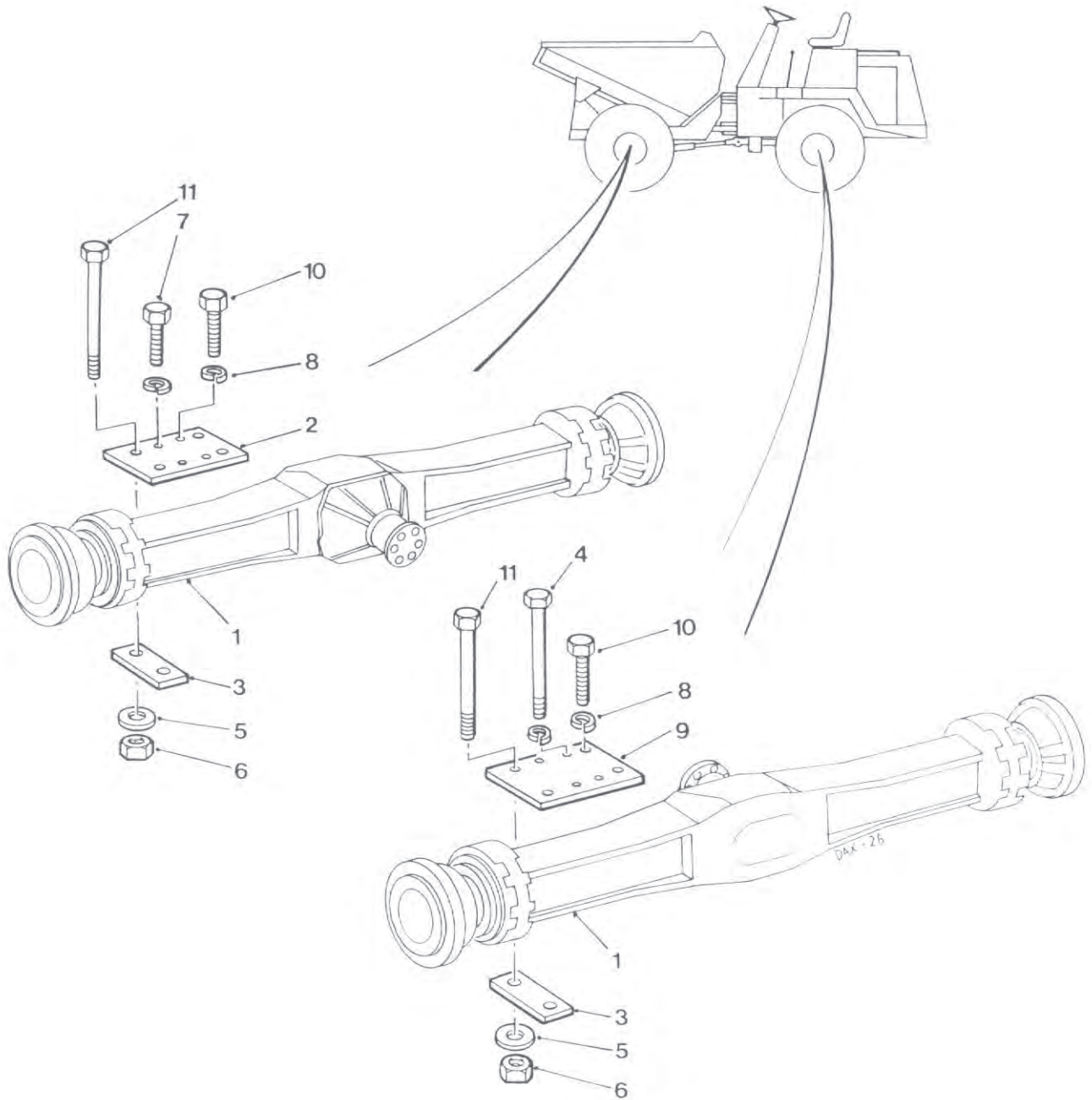

AXLE MOUNTS

2 - B - 1

Item	Part no	Axle serial no	Description	Qty
1	-	0000101/	AXLE (see page 2 - B - 2)	2
2	V2000928		PLATE, upper, front axle	1
3	V2000930		PLATE, lower	4
4	8S07AA		BOLT	4
5	267S10		WASHER, flat	16
6	59S05		NUT, nylon insert	16
7	11S06F		SCREW	12
8	17S08		WASHER, spring	16
9	V2000929		PLATE, upper, rear axle	2
10	11S06H		SCREW	4
11	8S07Z		BOLT	12

4C4000 & 4C5000 Dumper, from machine serial no. BC01186

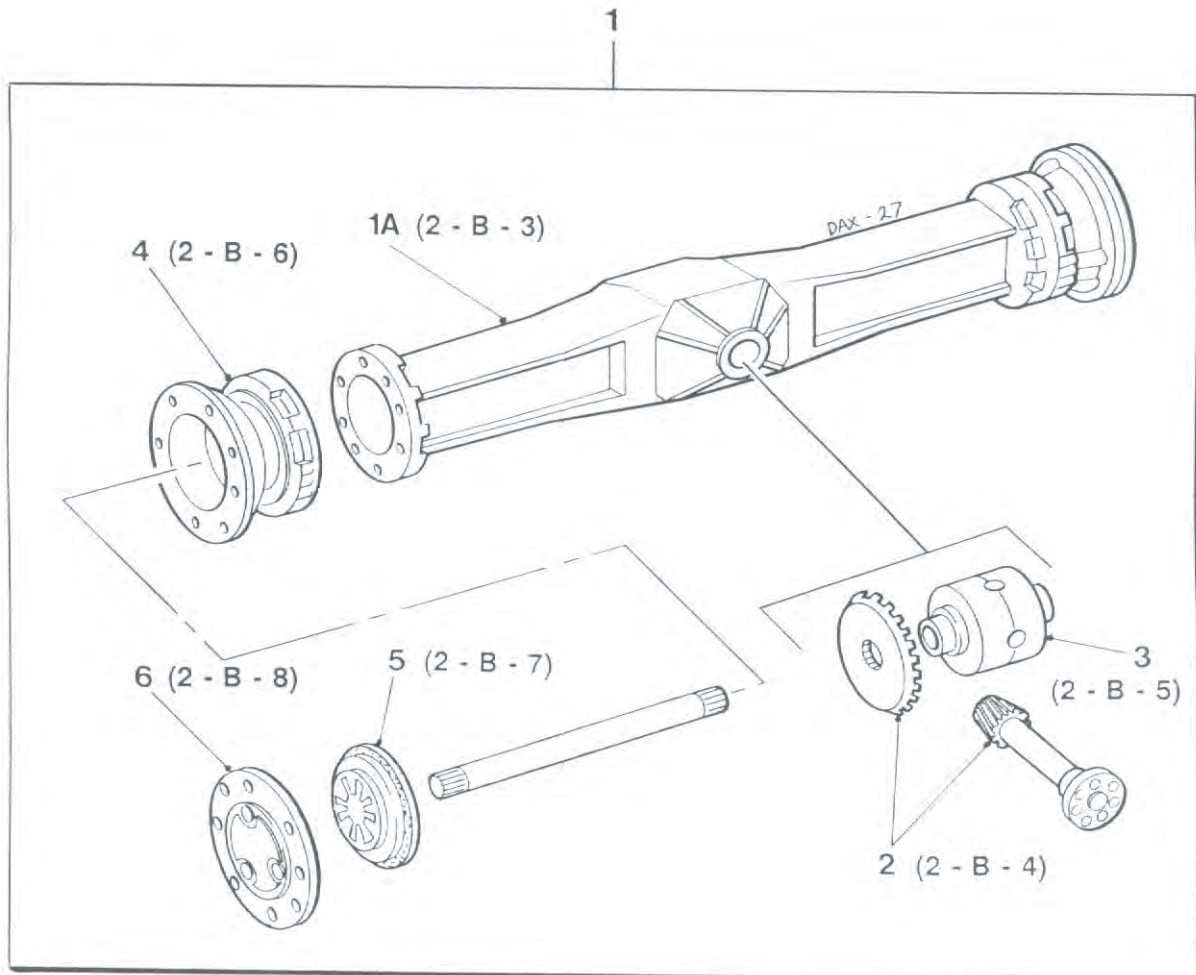

AXLES

2 - B - 2

Item	Part no	Axle Serial no	Description	Qty
1	V2000592	0000101/	AXLE, assembly	2
1A	page 2 - B - 3		HOUSING & MOUNTS	1
2	page 2 - B - 4		CROWN WHEEL & PINION	1
3	page 2 - B - 5		DIFFERENTIAL	1
4	page 2 - B - 6		WHEEL HUB	2
5	page 2 - B - 7		BRAKES & DRIVESHAFTS	2
6	page 2 - B - 8		EPICYCLIC REDUCTION GEARS	2

4C4000 & 4C5000 Dumper, from machine serial no. BC01186

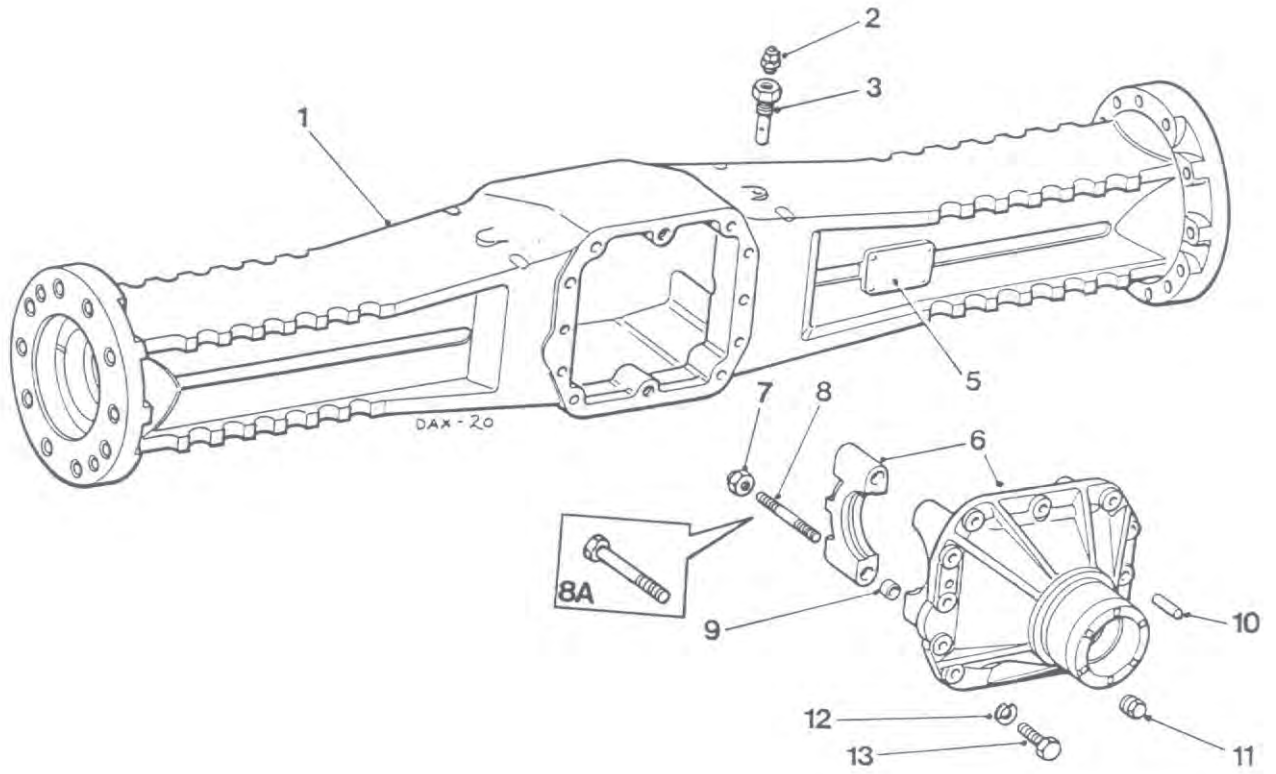

AXLE HOUSING

2 - B - 3

Item	Part no	Axle Serial no	Description	Qty
1	V600072	0000101/	HOUSING, axle	1
2	V600196	0000101/	BREATHER	1
3	V600461	0000101/	ADAPTOR, breather	1
5	-	0000101/	PLATE, serial (see page 9 - A - 1)	1
6	V600200	0000101/	SUPPORT, differential	1
7	V600075	0000101/0000387	NUT	4
8	V600199	0000101/0000387	STUD	4
8A	V600162	0000388/	BOLT	4
9	V600076	0000101/	BUSH	4
10	V600077	0000101/	PIN	2
11	V600078	0000101/	PLUG, drain	2
12	V600079	0000101/	WASHER	10
13	V600080	0000101/	BOLT	10

4C4000 & 4C5000 Dumper, from machine serial no. BC01186

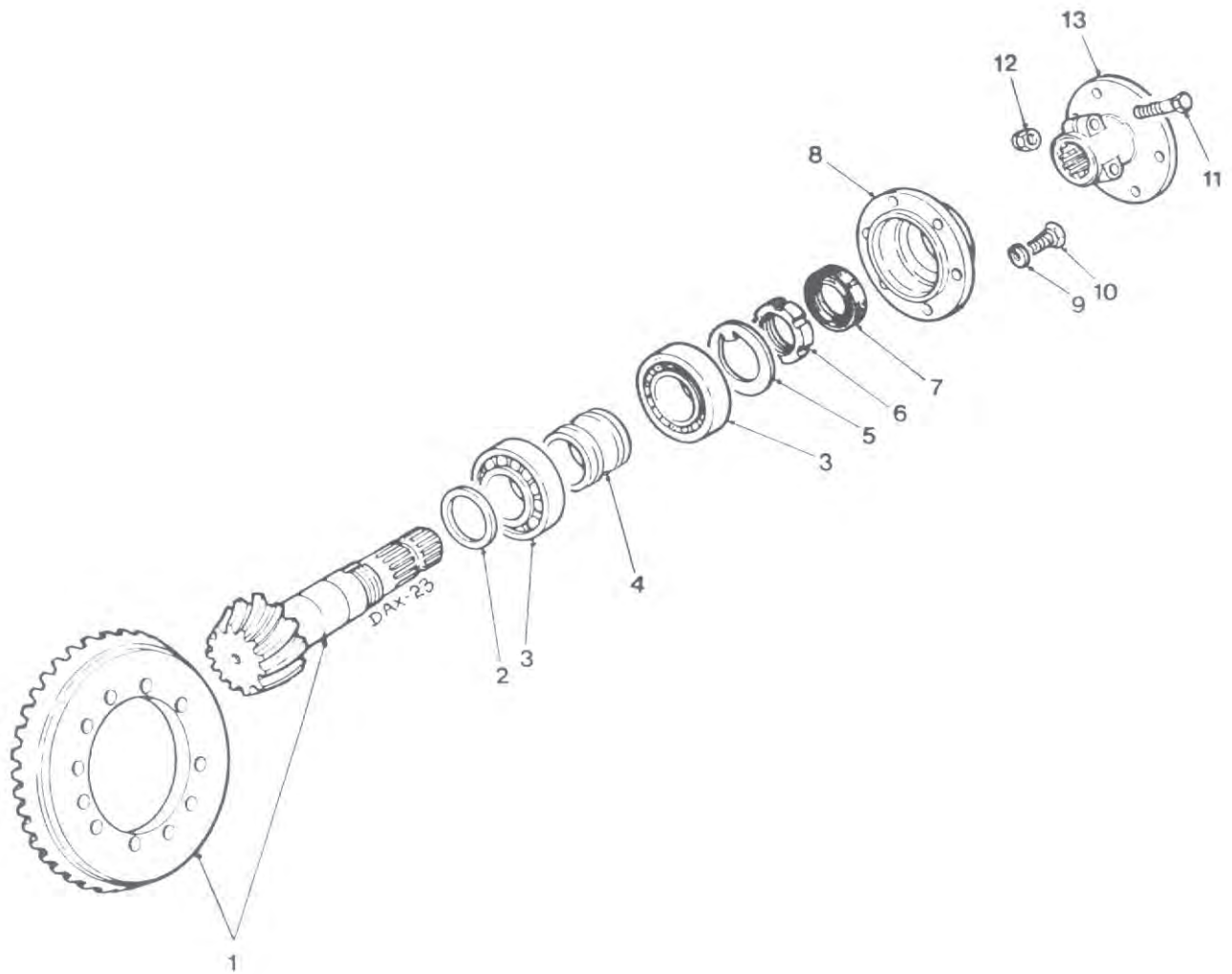

CROWN WHEEL & PINION

2 - B - 4

Item	Part no	Axle Serial no	Description	Qty
1	V600081	0000101/	CROWN WHEEL & PINION	1
2	V600205		SHIM, 2.50mm	AR
2	V600206		SHIM, 2.60mm	AR
2	V600207		SHIM, 2.70mm	AR
2	V600208		SHIM, 2.80mm	AR
2	V600209		SHIM, 2.90mm	AR
2	V600210		SHIM, 3.00mm	AR
2	V600211		SHIM, 3.10mm	AR
2	V600212		SHIM, 3.20mm	AR
2	V600213		SHIM, 3.30mm	AR
2	V600214		SHIM, 3.40mm	AR
3	V600215		BEARING	2
4	V600480		SPACER, collapsible	1
5	V600216		WASHER	1
6	V600217		NUT, ring	1
7	V600201		SEAL, oil	1
8	V600218		COVER	1
9	17S03		WASHER, spring	6
10	V600219		BOLT	6
11	8S04H		BOLT	2
12	V600220		NUT, nylon insert	2
13	V600221		FLANGE	1

4C4000 & 4C5000 Dumper, from machine serial no. BC01186

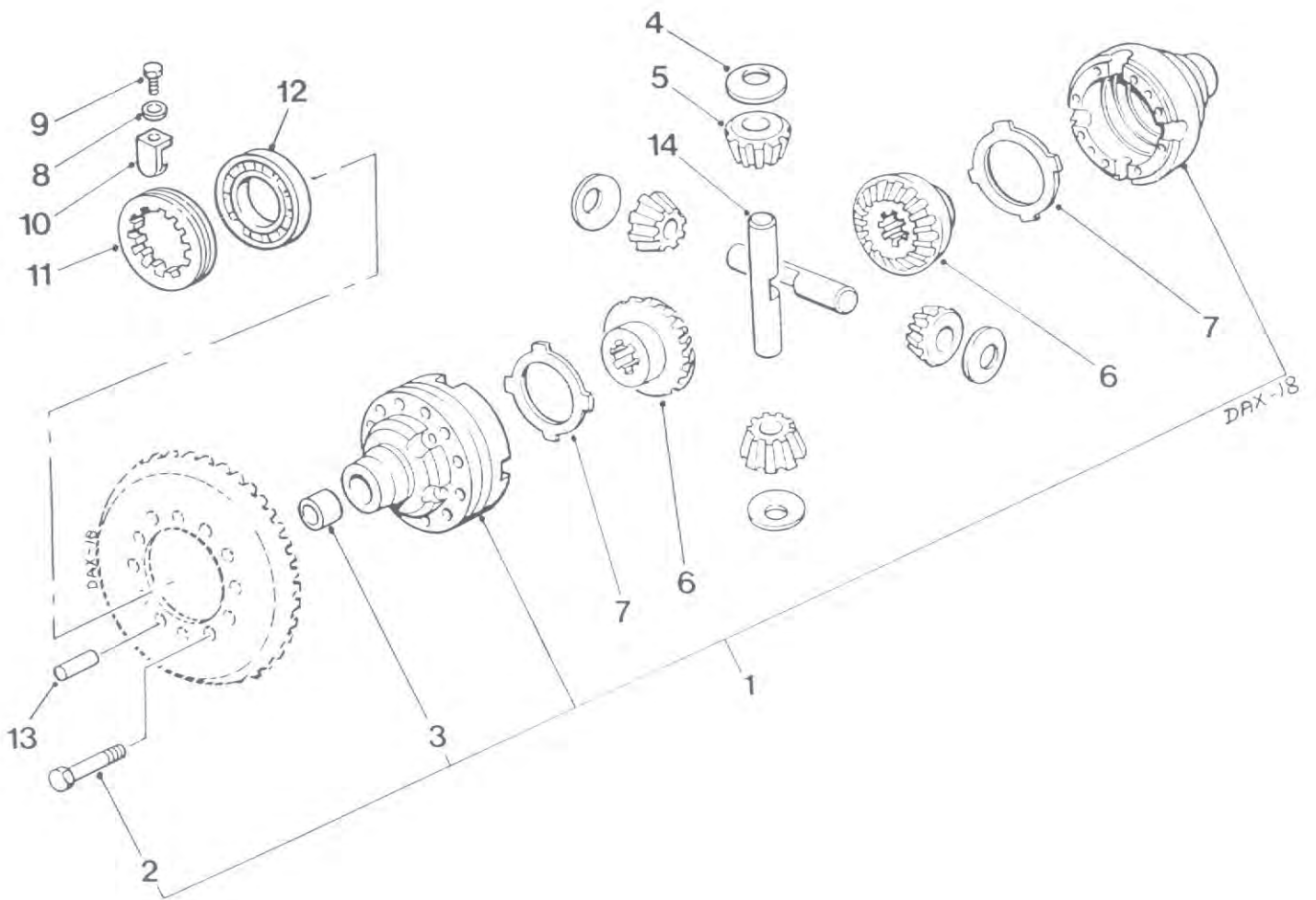

DIFFERENTIAL**2 - B - 5**

Item	Part no	Axle Serial no	Description	Qty
1	V600082	0000101/	HOUSING, matched pair	1
2	V600083		BOLT	12
3	V600084		BUSH	2
4	V600408		WASHER, thrust	2
5	V600477		PINION	2
6	V600085		PINION, side	2
7	V600086		PLATE	2
8	17S03		WASHER,. spring	2
9	V600222		BOLT	2
10	V600223		PLATE, locking	2
11	V600224		NUT, ring	2
12	V600225		BEARING	2
13	V600087		PIN, dowel	1
14	V600088		ROD, pinion	2

4C4000 & 4C5000 Dumper, from machine serial no. BC01186

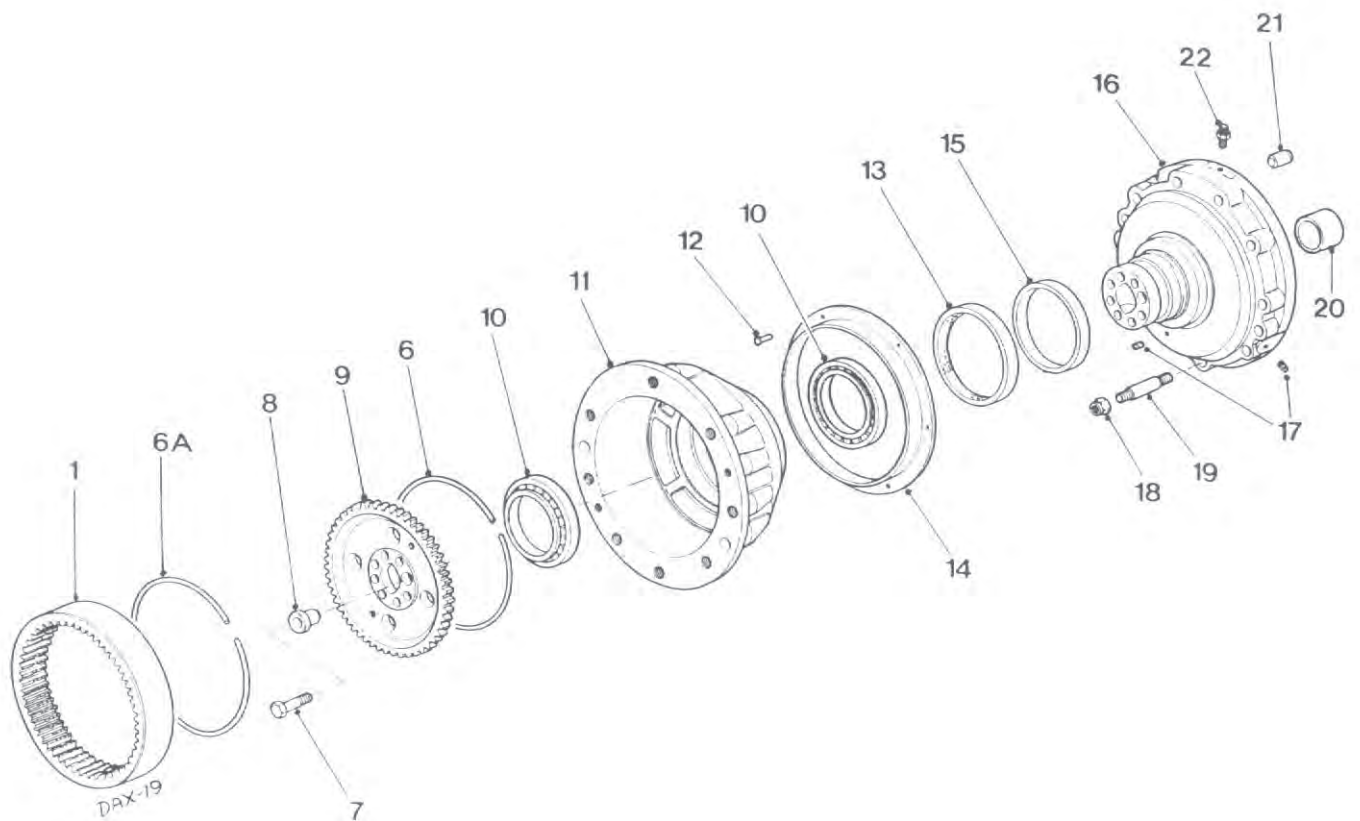

WHEEL HUB

2 - B - 6

Item	Part no	Axle Serial no	Description	Qty
1	V600231	0000101/0000343	CROWN WHEEL	2
1	V600502	0000344/	CROWN WHEEL	2
6	V600230	0000101/0000343	RING, locking	2
6	V600503	0000344/	RING, locking	2
6A	V600230	0000101/0000343	RING, locking	2
6A	-	0000344/	RING, locking (NOT USED)	
7	V600229	0000101/	BOLT	12
8	V600227	0000101/	BUSH, centring, 20mm diameter	10
8	V600228	0000101/	BUSH, centring, 24mm diameter	2
9	V600226	0000101/0000343	CARRIER, wheel	2
9	V600504	0000344/	CARRIER, wheel	2
10	V600232	0000101/	BEARING	4
11	V600417	0000101/	+ HUB, wheel	2
12	V600110	0000101/	RIVET	12
13	V600204	0000101/0000387	+ SEAL, oil (OBSOLETE: use V600501)	2
13	V600501	0000388/	SEAL, c/w wear ring	2
14	V600111	0000101/	RING	2
15	V600203	0000101/0000387	+ RING, wear (OBSOLETE: use V600501)	2
16	V600112	0000101/	+ SHAFT, hub	2
17	V600113	0000101/	PLUG	4
18	V600198	0000101/	NUT	20
19	V600114	0000101/	STUD	20
20	V600202	0000101/	BUSH	2
21	V600115	0000101/	PIN	4
22	V600116	0000101/	BREATHER	2

+ Note: If replacement of a wheel hub (V600417) or hub shaft (V600112) is required on axles prior to axle serial number 0000388, the seal (V600501) must also be ordered.

4C4000 & 4C5000 Dumper, from machine serial no. BC01186

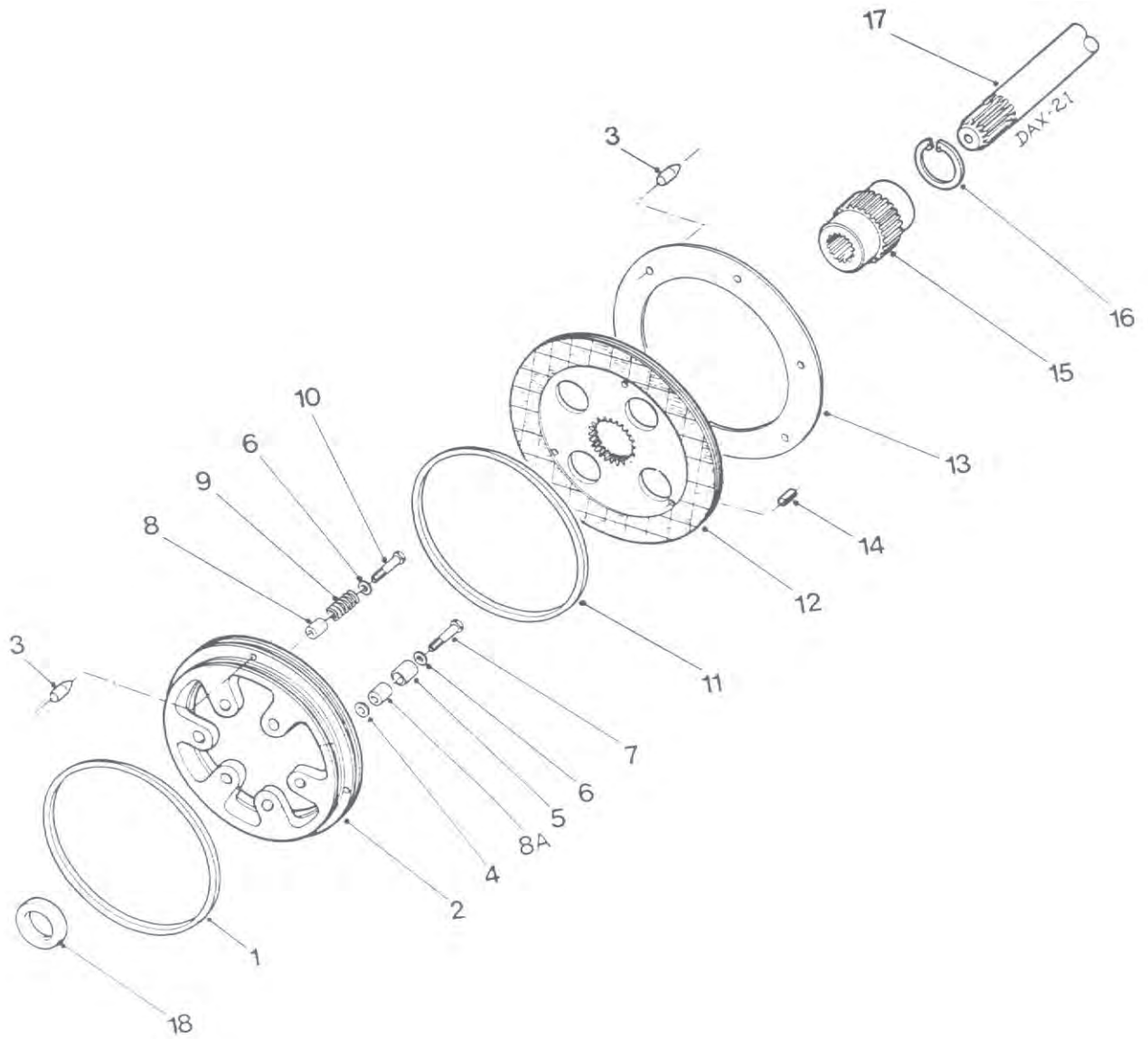

BRAKES

2 - B - 7

Item	Part no	Axle Serial no	Description	Qty
1	V600462	0000101/	RING	2
2	V600089	0000101/	PISTON	2
3	V600464	0000101/	PIN	12
4	V600482	0000101/0000343	+ WASHER	6
5	V600483	0000101/0000343	+ BUSH	6
6	V600090	0000101/0000343	+ WASHER	12
7	V600091	0000101/0000343	+ BOLT	6
8	V600092	0000101/0000343	+ BUSH	6
8A	-	0000101/0000343	+ "NOT USED"	
9	V600093	0000101/0000343	+ SPRING	6
10	V600094	0000101/0000343	+ BOLT	6
4	-	0000344/	\$ "NOT USED"	
5	V600483	0000344/	\$ BUSH	6
6	V600498	0000344/	\$ WASHER	12
7	V600499	0000344/	\$ SCREW	6
8	V600496	0000344/	\$ BUSH	6
8A	V600496	0000344/	\$ BUSH	6
9	V600497	0000344/	\$ SPRING	6
10	V600499	0000344/	\$ SCREW	6

Note: Components marked + cannot be mixed with components marked \$. However, ALL components marked + can be replaced by ALL components marked \$ as a complete assembly.

11	V600095	0000101/	RING	2
12	V600096	0000101/	DISC, brake	2
13	V600097	0000101/	PLATE	2
14	V600098	0000101/	PIN, split	8
15	V600099	0000101/	SLEEVE	2
16	V600100	0000101/	CIRCLIP	2
17	V600101	0000101/	DRIVESHAFT	2
18	V600102	0000101/	SEAL	2

4C4000 & 4C5000 Dumper, from machine serial no. BC01186

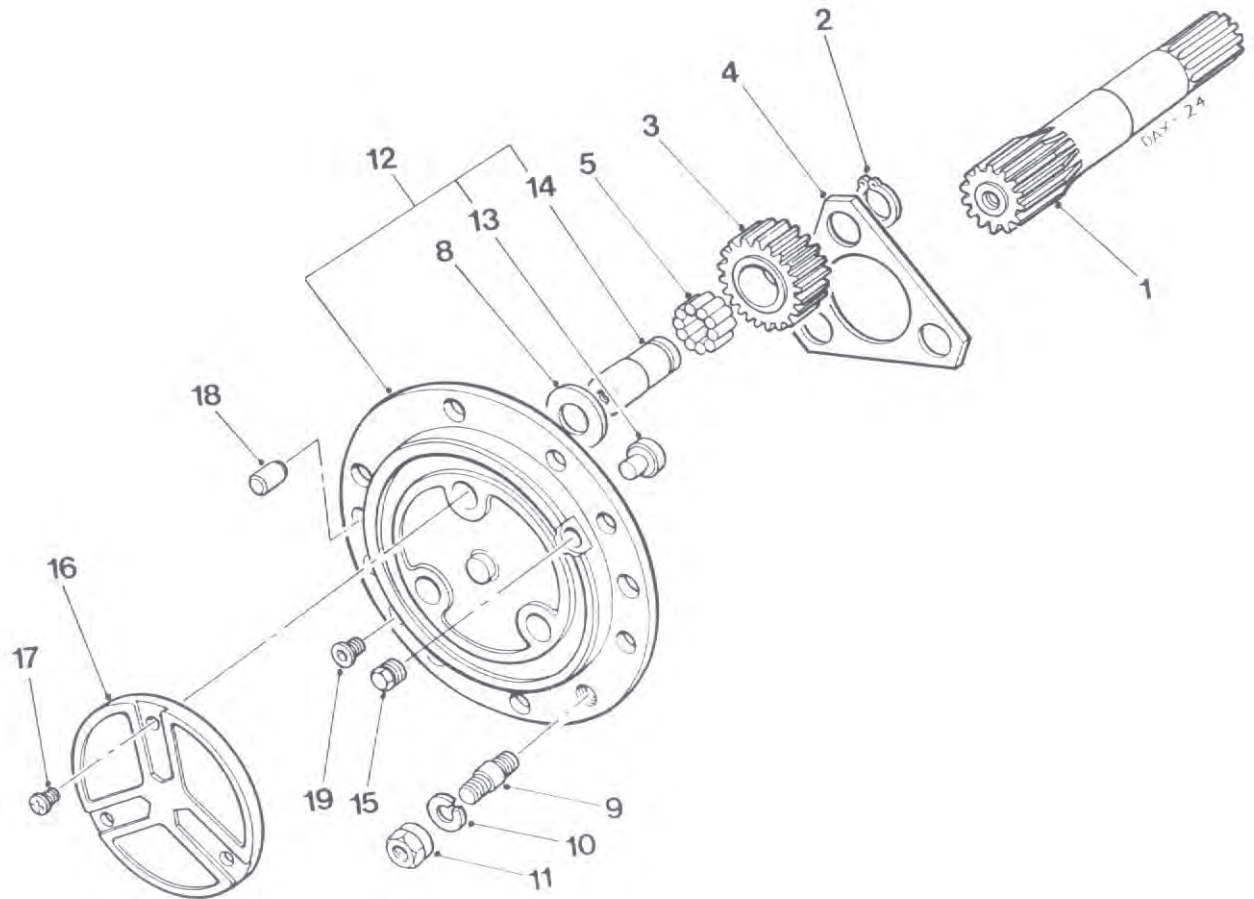

EPICYCLIC REDUCTION GEARS

2 - B - 8

Item	Part no	Axle Serial no	Description	Qty
1	V600103	0000101/	SHAFT	2
2	V600104		'O' RING	6
3	V600105		PINION	6
4	V600106		WASHER, thrust	2
5	V600107		BEARING, needle	180
8	V600864		WASHER	6
9	V600234		STUD BOLT	12
9	V600418		STUD BOLT, with collar	4
10	-		WASHER (see page 2 - W - 1)	16
11	-		NUT (see page 2 - W - 1)	16
12	V600108		CARRIER, assembly	2
13	V600233		PIN, lock	2
14	-		SHAFT (order assembly)	3
15	V600197		PLUG, drain	2
16	V600481		COVER	2
17	V600463		SCREW	6
18	V600236		PIN	4
19	V600237		SCREW	4

4C4000 & 4C5000 Dumper

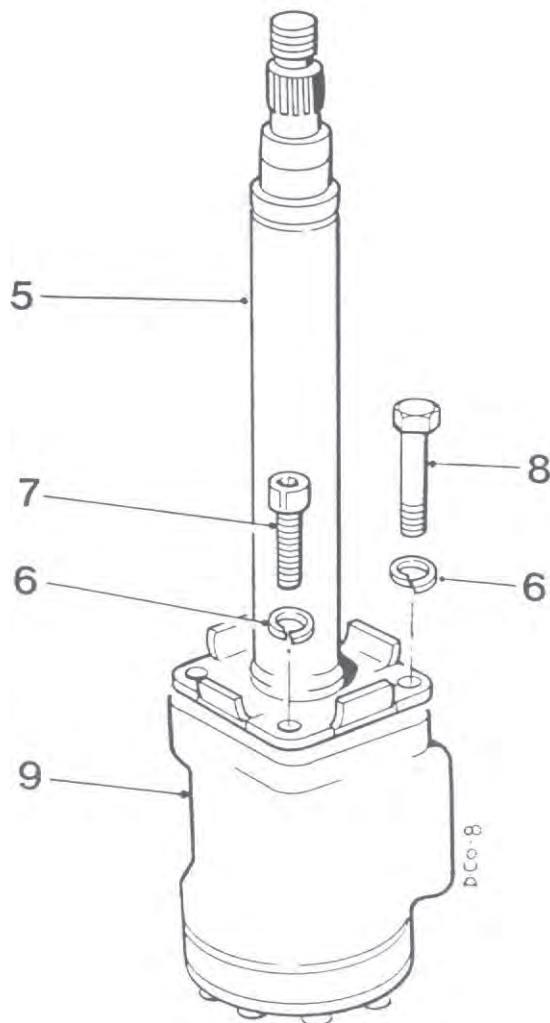
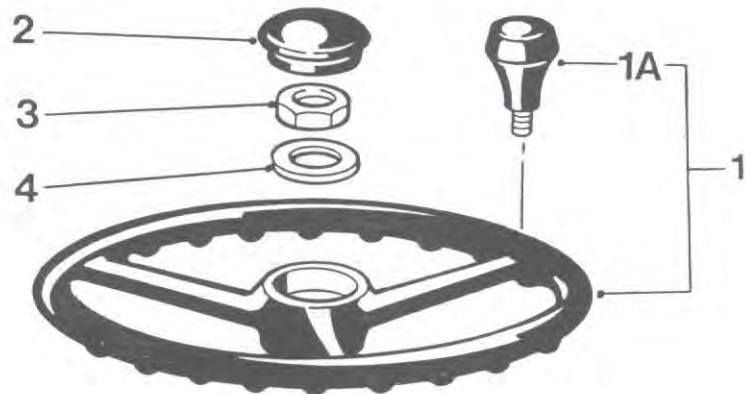

STEERING COLUMN

2 - S - 1

Item	Part no	Serial no	Description	Qty
1	V2003164	AA01000/	WHEEL, steering	1
1A	V600491	AA01000/	KNOB, steering wheel	1
2	V2003160	AA01000/	CAP, steering wheel	1
3	95S06	AA01000/	NUT	1
4	10S27	AA01000/	WASHER	1
5	V2003185	AA01000/	COLUMN, steering	1
6	41S05	AA01000/	WASHER, spring	4
7	103S04B	AA01000/	SCREW, socket head	2
8	69S03G	AA01000/	BOLT	2
9	-	AA01000/	STEER UNIT (See Hydraulics Section)	1

4C4000 Dumper

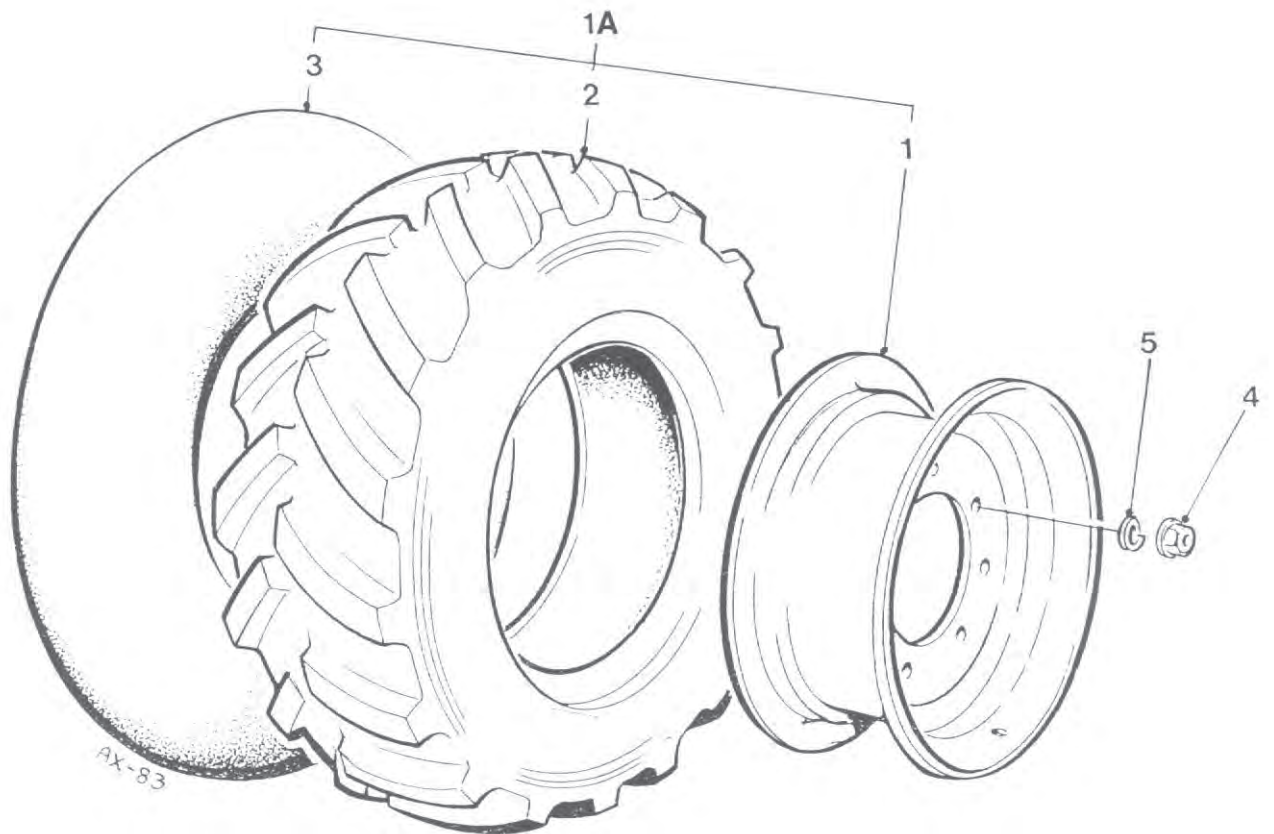

WHEELS & TYRES

2 - W - 1

Item	Part no	Serial no	Description	Qty
1A	24S09	AA01000/ BL01185	WHEEL, L.H., assembly	2
1A	24S10		WHEEL, R.H., assembly	2
1	30181A01		RIM, wheel, 11 x 18	1
2	20S12		TYRE, 12.5 x 18 10 PR	1
3	23S05		TUBE, 12.5 x 18	1
4	ESE260		NUT, wheel	32
1A	24S72	BL01186/	WHEEL, L.H., assembly	2
1A	24S73		WHEEL, R.H., assembly	2
1	V2000925		RIM, wheel, 11 x 18	1
2	20S12		TYRE, 12.5 x 18 x 10PR	1
3	23S05		TUBE, 12.5 x 18	1
4	V600423		NUT, wheel	32
5	V600235		WASHER	32

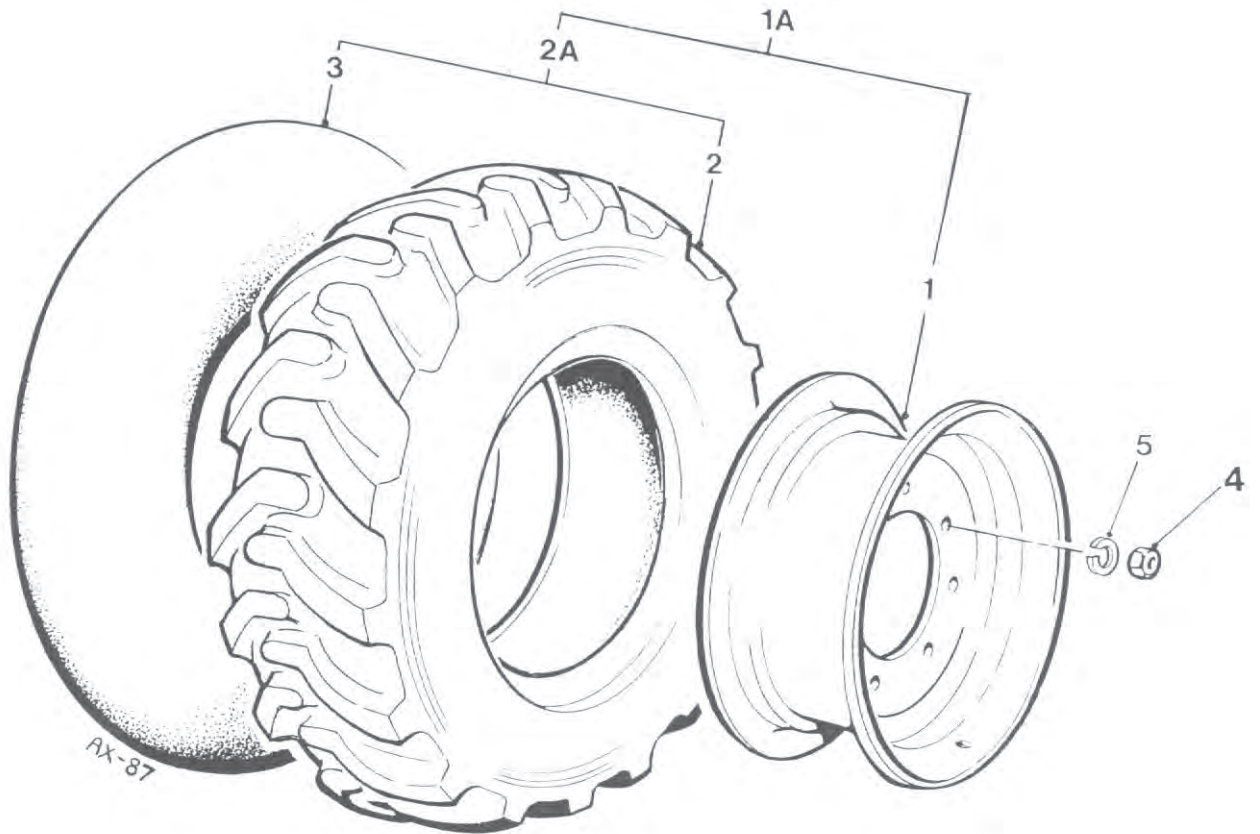

WHEELS & TYRES

2 - W - 2

Item	Part no	Serial no	Description	Qty
1A	24S78	BF01221/	WHEEL, L.H., assembly	2
1A	24S79		WHEEL, R.H., assembly	2
1	V2000925		RIM, wheel, 11 x 18	1
2A	V2003221		TYRE, c/w tube	1
2	V600475		TYRE, 12.0/12.5 x 18 12PR ATU	1
3	V600476		TUBE, 12.0/12.5 x 18	1
4	V600423		NUT	32
5	V600235		WASHER	32

ENGINE

- 3 - A - 1 ENGINE & MOUNTINGS

- 3 - B - 1 EXHAUST, to Jan 1990
- 3 - B - 1A EXHAUST, from Jan 1990

- 3 - C - 1 FUEL TANK / L.H. WING

- 3 - D - 1 AIR CLEANER

- 3 - E - 1 ACCELERATOR PEDAL & LINKAGE

- 3 - F - 1 ROD, ENGINE STOP

4C4000 & 4C5000 Dumper

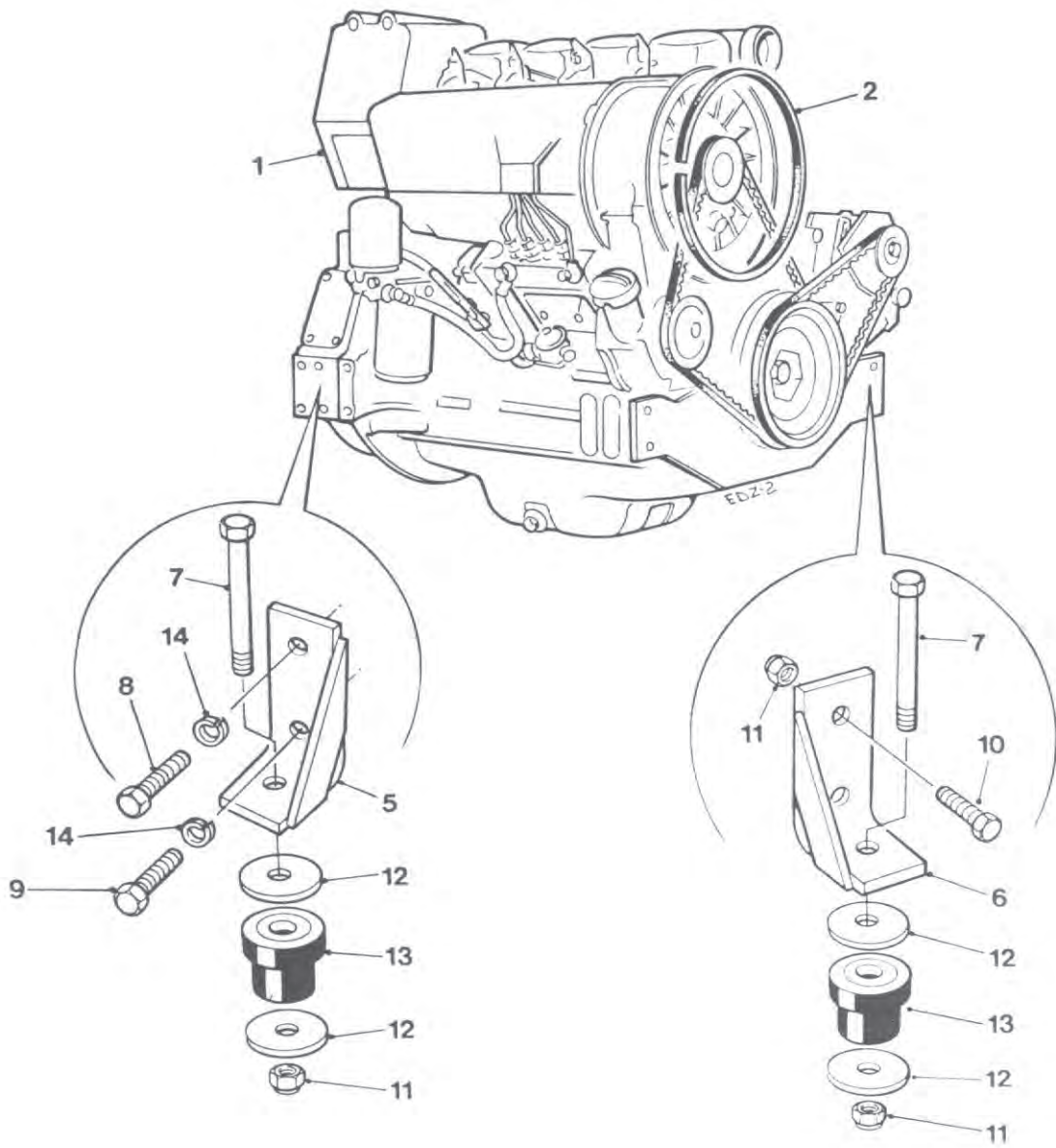

ENGINE & MOUNTINGS

3 - A - 1

Item	Part no	Serial no	Description	Qty
1	V2000002	AA01000/	ENGINE, Deutz, machines without cabs	1
1	V2002514	AA01000/	ENGINE, Deutz, machines with cabs	1

NOTE: There are certain differences on engines fitted to machines built with cabs.

Be sure to ascertain whether the machine has a factory-fitted cab before ordering engine parts.

2	V2003225		SEAL, rubber (order by metre)	AR
5	V2000339		BRACKET, L.H.	2
6	V2000340		BRACKET, R.H.	2
7	8S05M		BOLT	4
8	11S05C		SCREW, set	2
9	11S05E		SCREW, set	2
10	11S05F		SCREW, set	4
11	59S04		NUT, nylon insert	8
12	V2003218		WASHER, special	8
13	V2003216		MOUNT, rubber	4
14	17S06		WASHER, spring	4

4C4000 & 4C5000 Dumper, to January 1990

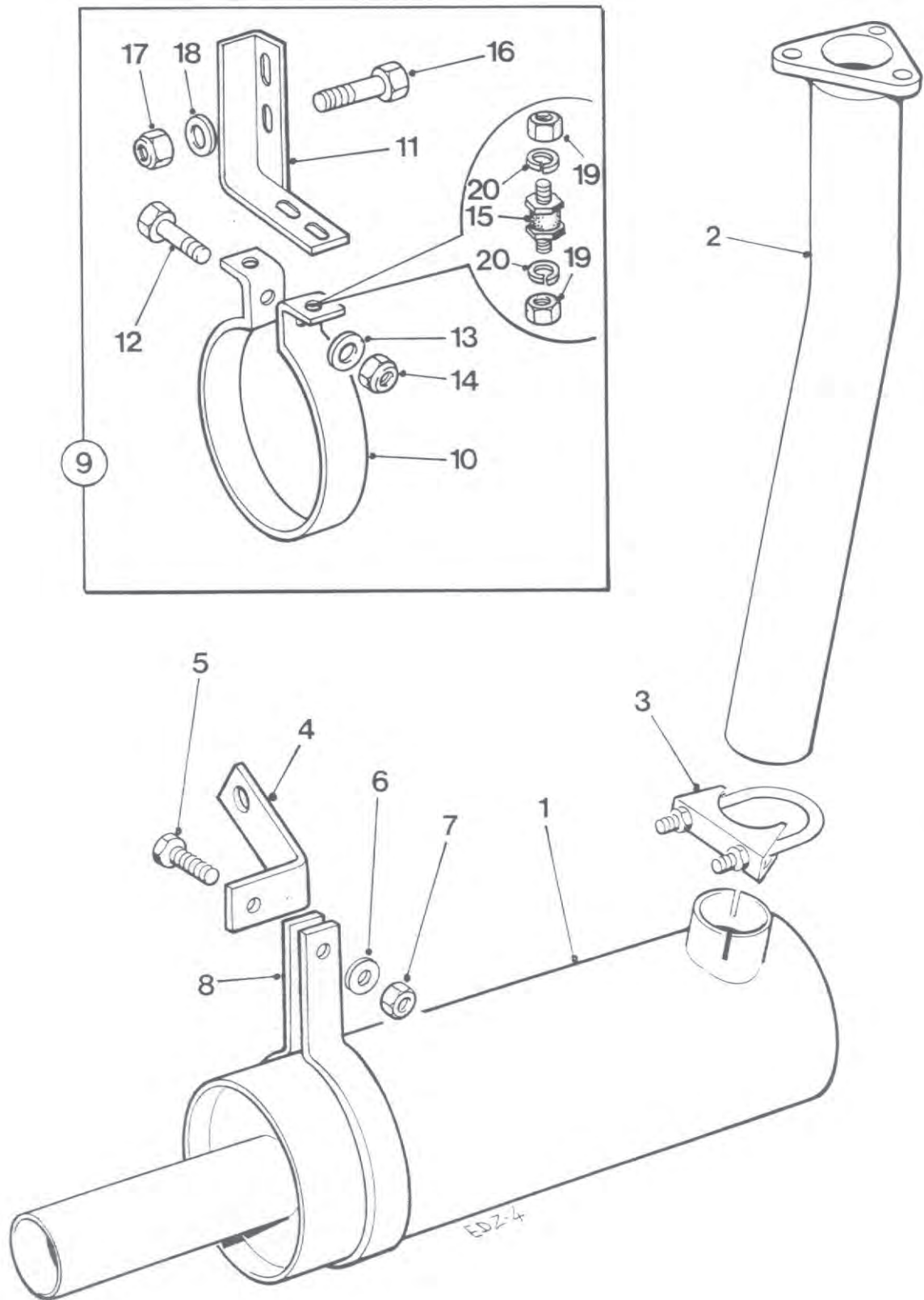

EXHAUST

3 - B - 1

Item	Part no	Serial no	Description	Qty
1	V2000293	AA01000/JAN 90	SILENCER	1
2	V2000294	AA01000/JAN 90	PIPE, exhaust	1
3	153S12	AA01000/JAN 90	CLAMP, pipe	1
4	V2000409	AA01000/BF01220	BRACKET (OBSOLETE: use conversion kit V600144)	1
5	11S04B	AA01000/BF01220	SCREW, set	1
6	267S06	AA01000/BF01220	WASHER, flat	1
7	61S04	AA01000/BF01220	NUT	1
8	V2000417	AA01000/BF01220	CLAMP (OBSOLETE: use conversion kit V600144)	1
9	V600144	BF01221/JAN 90	KIT, conversion	1
10	V2001641	BF01221/JAN 90	CLAMP	1
11	V2001642	BF01221/JAN 90	BRACKET	1
12	8S02D	BF01221/JAN 90	BOLT	1
13	267S04	BF01221/JAN 90	WASHER	1
14	61S02	BF01221/JAN 90	NUT, self locking	1
15	V601143	BF01221/JAN 90	MOUNT, rubber	2
16	8S05F	BF01221/JAN 90	BOLT	2
17	7S05	BF01221/JAN 90	NUT	2
18	12S23	BF01221/JAN 90	WASHER, flat	2
19	7S04	BF01221/JAN 90	NUT	4
20	17S05	BF01221/JAN 90	WASHER, spring	4

4C4000 & 4C5000 Dumper, from January 1990

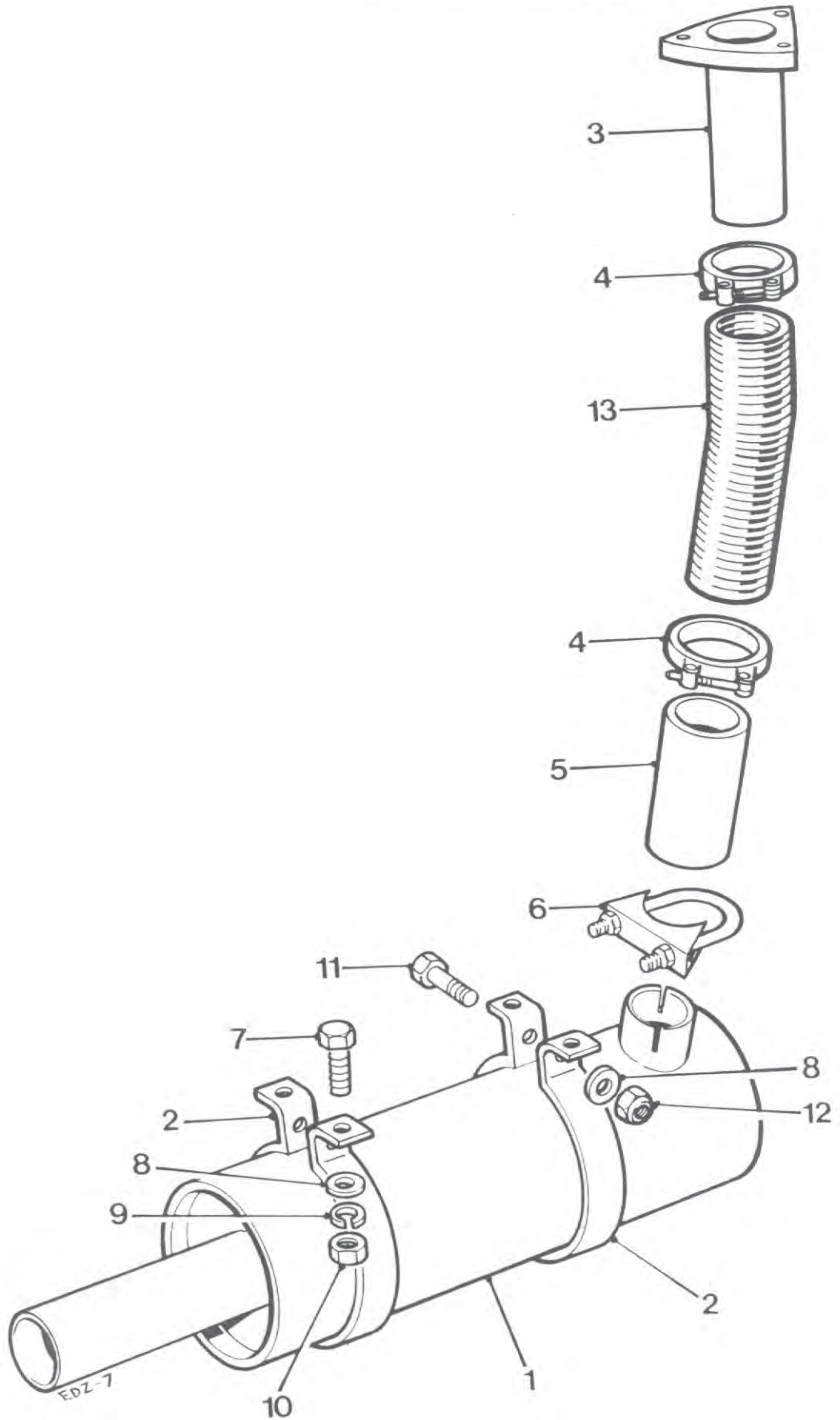

EXHAUST

3 - B - 1A

Item	Part no	Serial no	Description	Qty
1	V2000293	JAN 90/	SILENCER	1
2	V2001641	JAN 90/	CLAMP, silencer	2
3	V2002394	JAN 90/	PIPE, exhaust	1
4	V2003240	JAN 90/	CLAMP, exhaust	2
5	V2002395	JAN 90/	PIPE, exhaust	1
6	153S12	JAN 90/	CLAMP	1
7	11S03C	JAN 90/	SCREW, set	4
8	267S05	JAN 90/	WASHER, flat	6
9	17S04	JAN 90/	WASHER, spring	4
10	7S03	JAN 90/	NUT	4
11	8S02D	JAN 90/	BOLT	2
12	61S02	JAN 90/	NUT, self locking	2
13	V2002466	JAN 90/	HOSE, flexible	1

4C4000 & 4C5000 Dumper

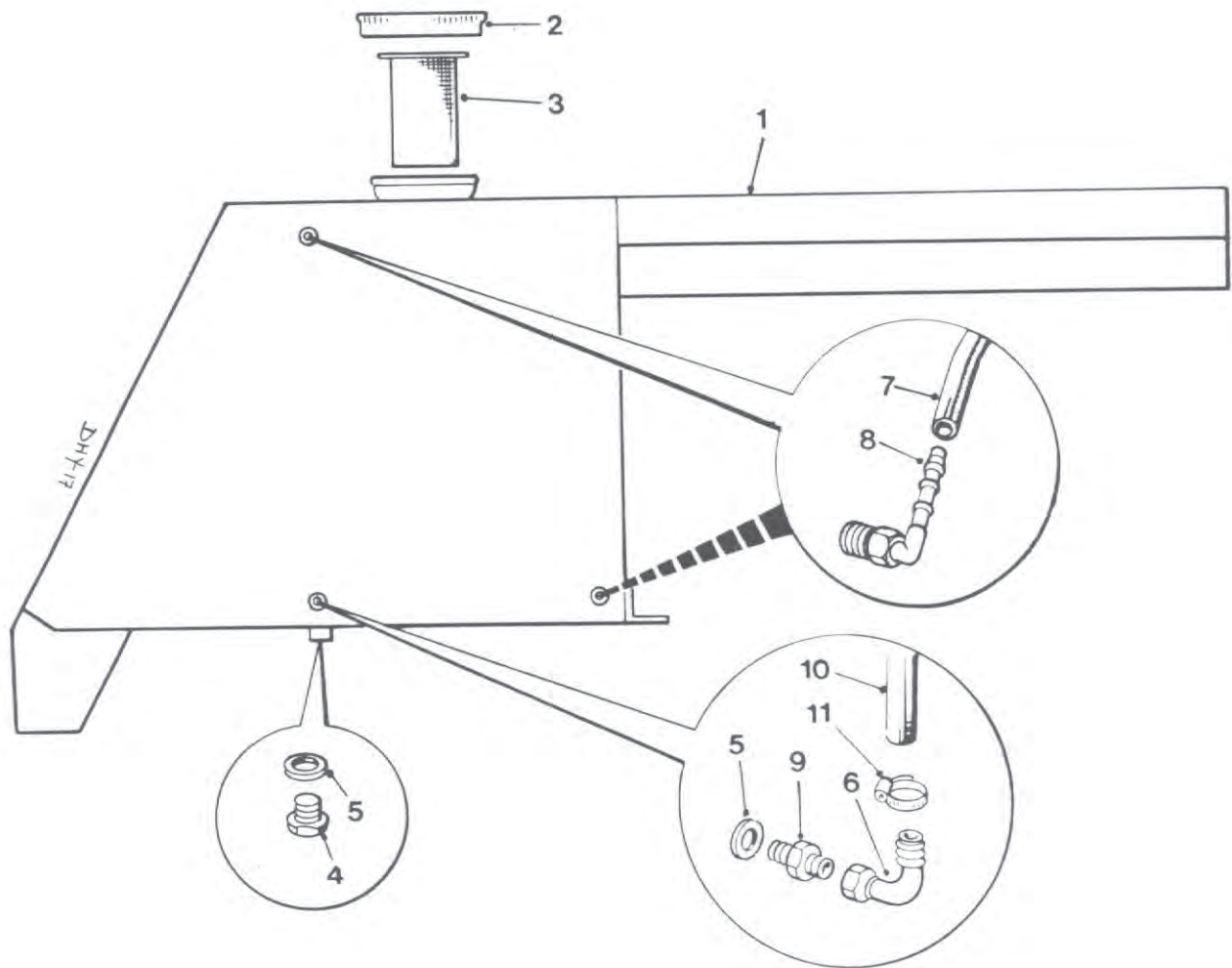

FUEL TANK/L.H. WING**3 - C - 1**

Item	Part no	Serial no	Description	Qty
1	V2000224	AA01000/	TANK, fuel/L.H. wing	1
2	10378A01		CAP, filler	1
3	10379A01		FILTER	1
4	V2003210		PLUG	1
5	100S02		SEAL, bonded	2
6	129S02B		ADAPTOR, elbow	1
7	29S05		TUBE, nylon (order by metre)	AR
8	V2003209		ELBOW	1
9	119S03		ADAPTOR	1
10	V2003187		TUBE, plastic (order by metre)	AR
11	97S01		CLIP, hose	2

4C4000 & 4C5000 Dumper

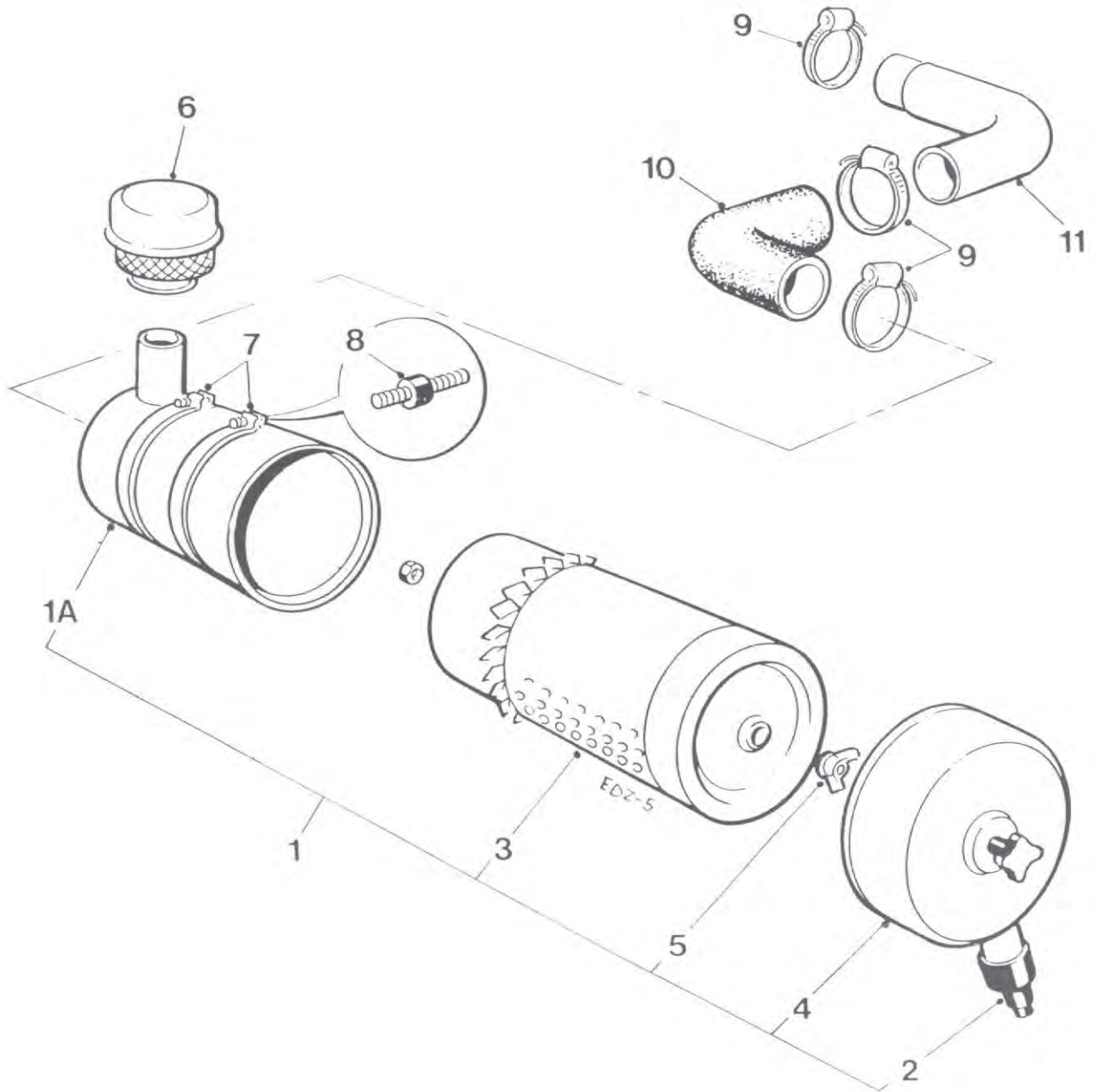

AIR CLEANER

3 - D - 1

Item	Part no	Serial no	Description	Qty
1	10532A05	AA01000/	AIR CLEANER, assembly	1
1A	-		AIR CLEANER (order assembly)	1
2	V600486		COLLECTOR, dust	1
3	V600484		ELEMENT, outer	1
4	V600485		COVER	1
5	V600487		NUT, wing	1
6	V2003201		PRE-CLEANER	1
7	10533A05		BAND CLAMP	2
8	013203000		MOUNTING, rubber	4
9	97S15		CLIP, pipe	4
10	V2003188		ELBOW, rubber	1
11	V2000310		PIPE, steel	1

4C4000 & 4C5000 Dumper

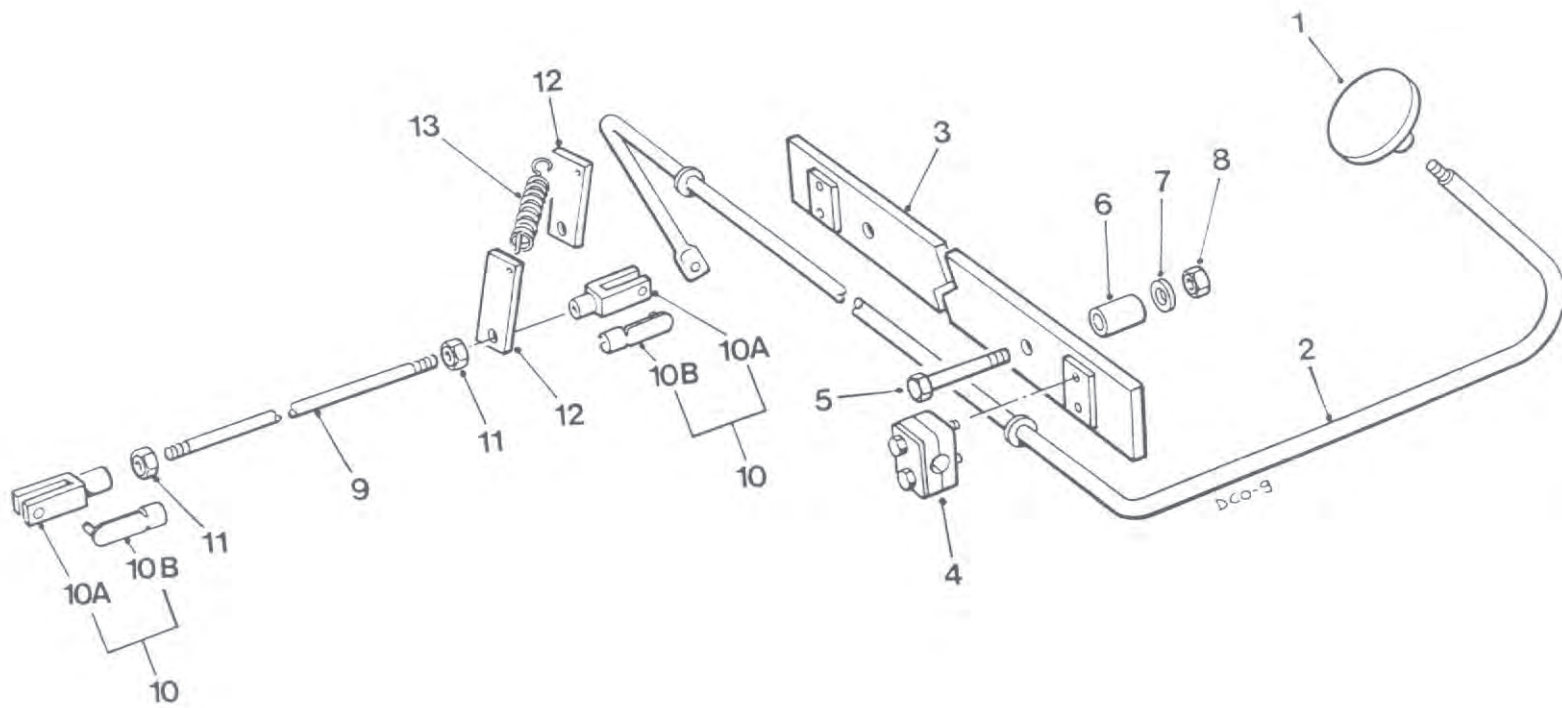

ACCELERATOR PEDAL & LINKAGE

3 - E - 1

Item	Part no	Serial no	Description	Qty
1	V2000343	AA01000/	PEDAL	1
2	V2000308		ROD, accelerator pedal	1
3	V2000321		BRACKET	1
4	10364A03		PIVOT BLOCK	2
5	8S04H		BOLT	2
6	V2000322		SPACER	2
7	267S18		WASHER, flat	2
8	59S03		NUT, nylon insert	2
9	V2000309		ROD	1
10	V2003191		CLEVIS, c/w pin (OBSOLETE: use V2003245) & V2003246)	2
10A	V2003245		CLEVIS	2
10B	V2003246		PIN, spring	2
11	7S02		NUT	2
12	V2000351		BRACKET	2
13	C1730		SPRING	1

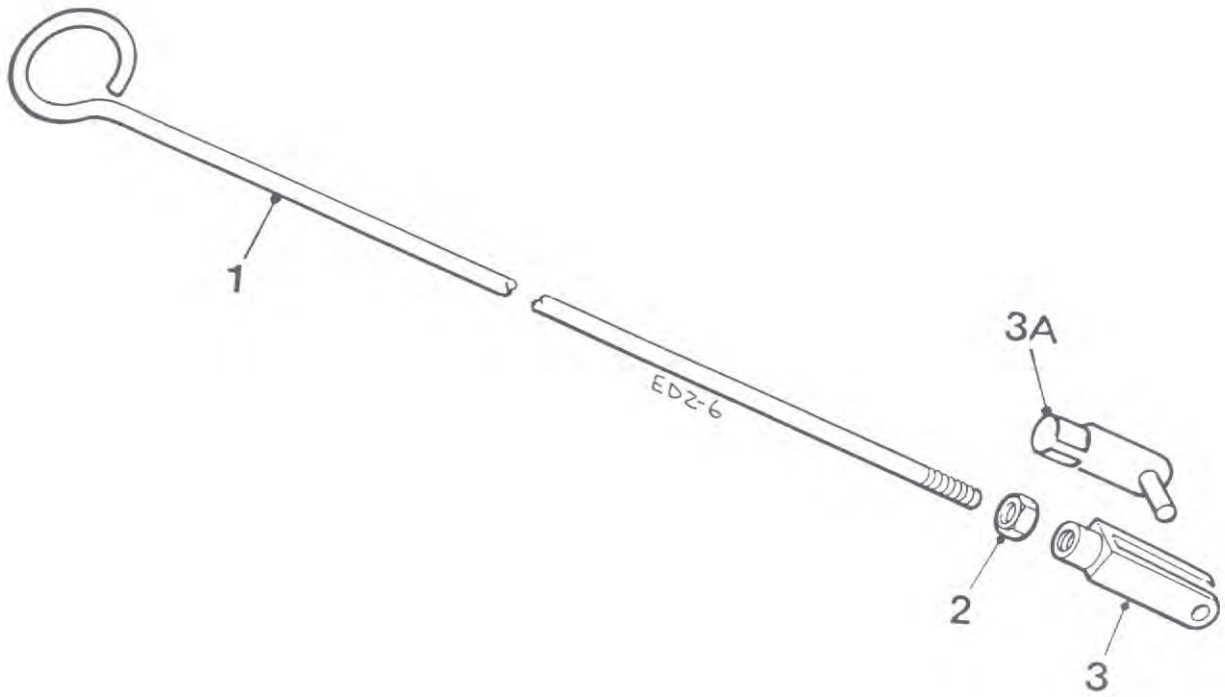

ROD, engine stop

3 - F - 1

Item	Part no	Serial no	Description	Qty
1	V2000297	AA01000/	ROD	1
2	7S02		NUT	1
3	V2003191		CLEVIS, c/w pin (OBSOLETE: use V2003245 & V2003246)	1
3	V2003245		CLEVIS	1
3A	V2003246		PIN, spring	1

TRANSMISSION

- 4 - A - 1 HYDRAULIC TRANSMISSION & GEARBOX

- 4 - B - 1 TORQUE CONVERTER
- 4 - B - 2 ADAPTOR - GEARBOX TO HYDRAULIC TRANSMISSION

- 4 - C - 1 HOUSING, hydraulic transmission
- 4 - C - 2 CLUTCHES & TORQUE CONVERTER PUMP
- 4 - C - 3 VALVE, forward/neutral/reverse
- 4 - C - 4 OIL COOLER, hydraulic transmission

- 4 - C - 4A OIL COOLER, transmission / CAB HEATER circuits

- 4 - C - 5 FORWARD/NEUTRAL/REVERSE CONTROL
- 4 - C - 6 DUMP PEDAL, hydraulic transmission

- 4 - D - 1 CASING, GEARBOX
- 4 - D - 2 GEARS & SHAFTS
- 4 - D - 3 GEAR LEVER

- 4 - E - 1 PROPELLER SHAFTS & TRANSFER GEARBOX

- 4 - F - 1 TRANSFER GEARBOX
- BRAKE, transfer gearbox - see Brake section
- 4 - F - 2 MOUNTING, transfer gearbox

4C4000 & 4C5000 Dumper

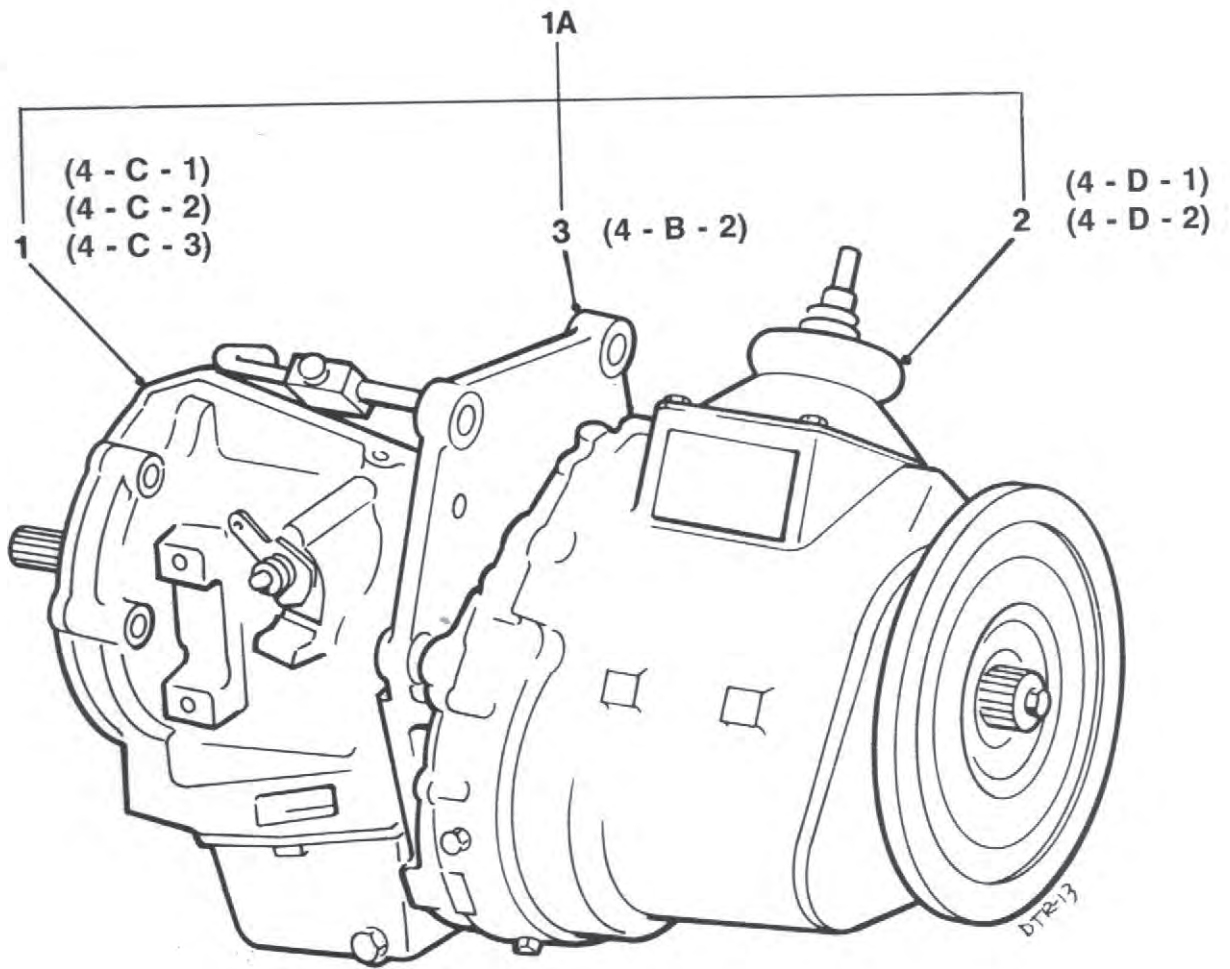

HYDRAULIC TRANSMISSION & GEARBOX

4 - A - 1

Item	Part no	Serial no	Description	Qty
-	V2003256	AA01000/	HYDRAULIC TRANSMISSION & GEARBOX, assy	1
1	V2003373		HYDRAULIC TRANSMISSION, assembly	1
2	V600412		GEARBOX, assembly	1
3	-		ADAPTOR, assembly (see page 4 - B - 2)	

4C4000 & 4C5000 Dumper

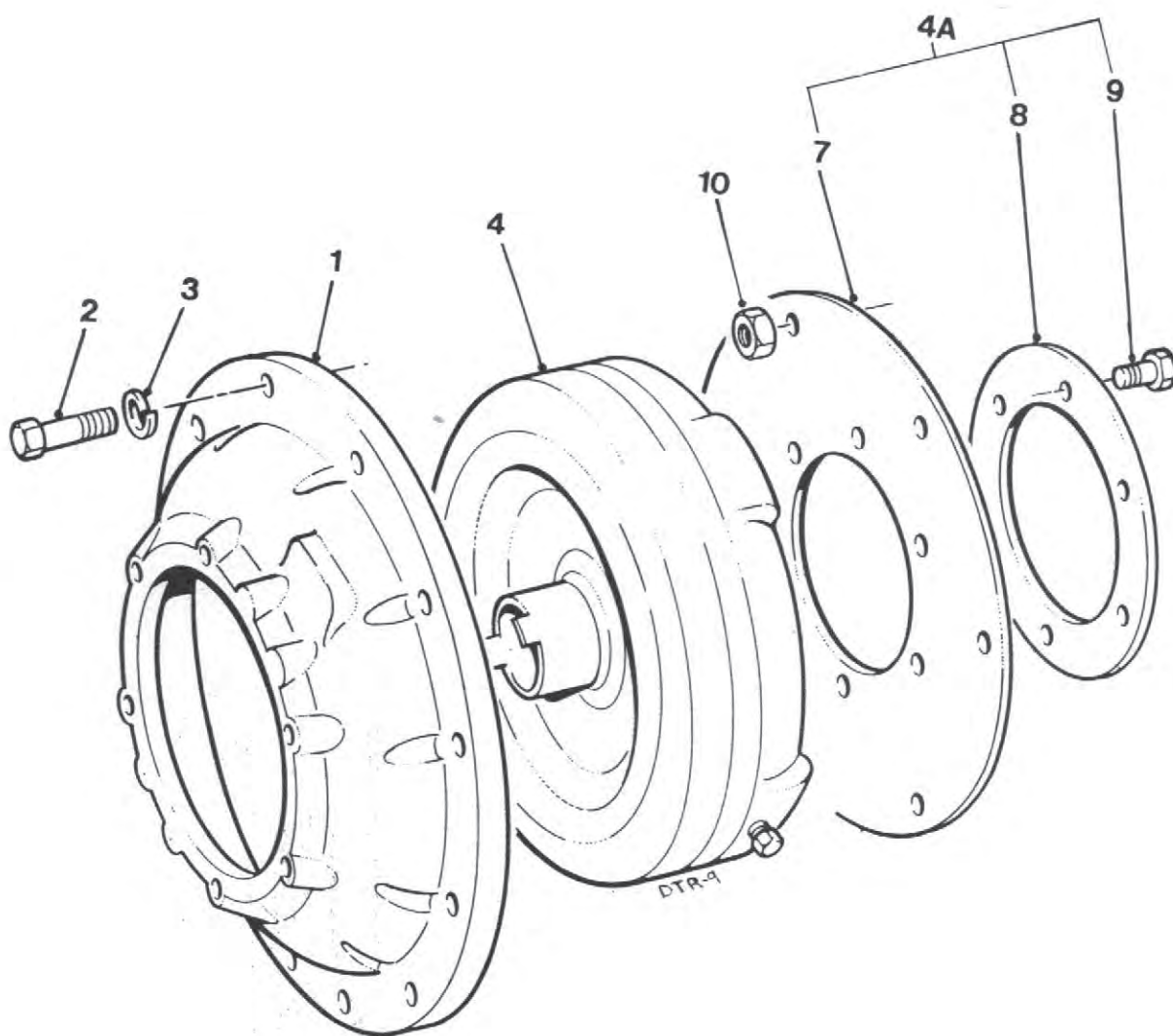

TORQUE CONVERTER

4 - B - 1

Item	Part no	Serial no	Description	Qty
1	V2003259	AA01000/	HOUSING	1
2	11S04C		SCREW, set	12
3	17S05		WASHER, spring	12
4	V2003257		TORQUE CONVERTER	1
4A	V2003258		DRIVE PLATE, assembly	1
7	-		DRIVE PLATE (order assembly)	1
8	-		SUPPORT, drive plate (order assembly)	1
9	-		SCREW, set (order assembly)	6
10	59S12		NUT, nylon insert	6

ADAPTOR - GEARBOX TO TRANSMISSION UNIT

4 - B - 2

Item	Part no	Serial no	Description	Qty
1A	V600416	AA01000/	ADAPTOR, assembly	1
1	V600257		ADAPTOR	1
2	V600343		SEAL	1
3	V600258		GASKET, adaptor to hyd. transmission	1
4	88S20		BEARING	1
5	V600256		BOLT	6
6	41S06		WASHER, spring	8
7	V600424		BOLT	2
8	V600425		BOLT	6

4C4000 & 4C5000 Dumper

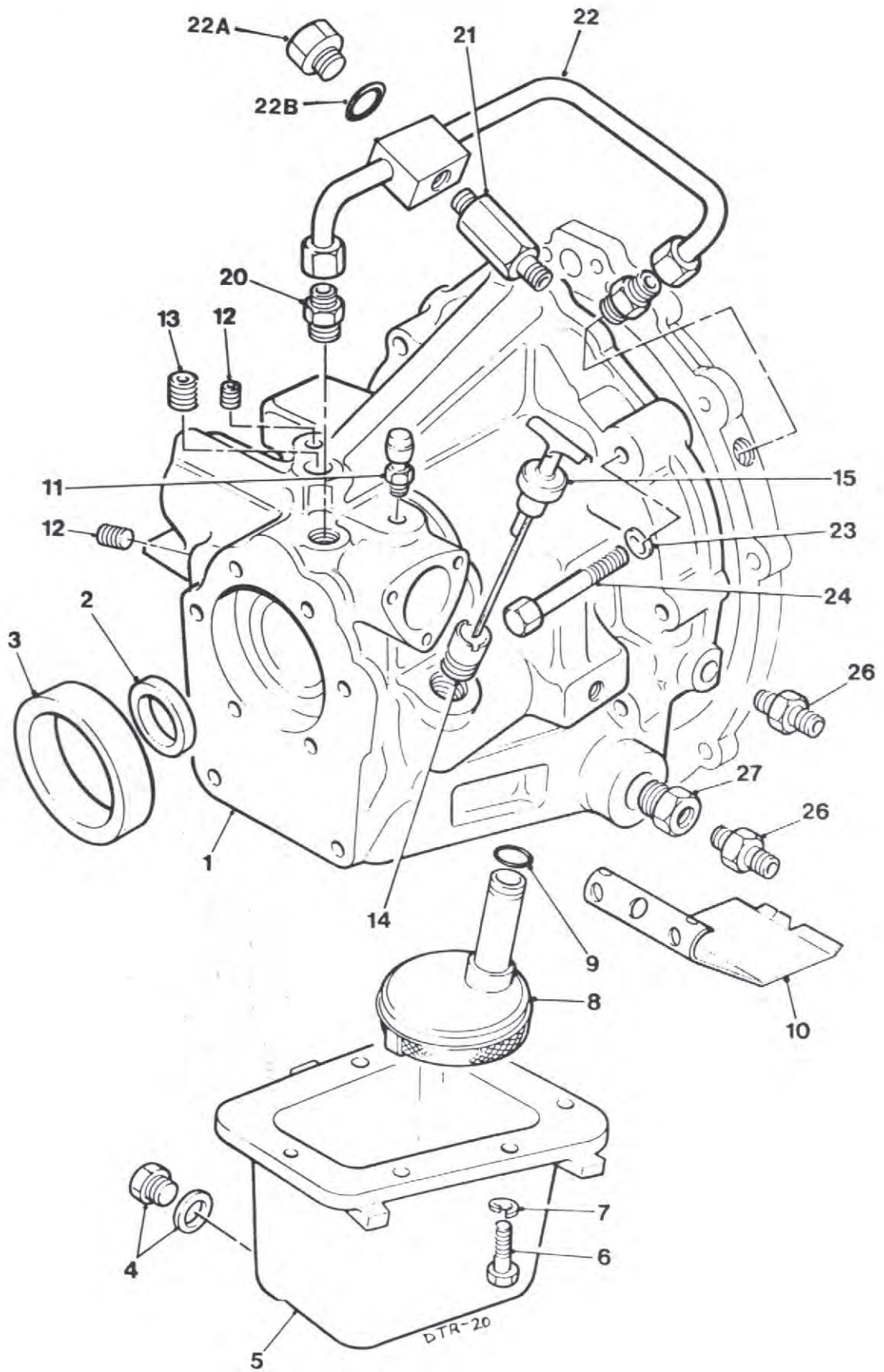

HOUSING, hydraulic transmission

4 - C - 1

Item	Part no	Serial no	Description	Qty
-	V600238	AA01000/	CASING, assembly	1
1	V600239		CASING	1
2	V600240		SPACER	1
3	V600241		SLEEVE	1
4	V600242		PLUG, drain & seal	1
5	V600243		SUMP	1
6	V600244		BOLT	7
7	V600245		WASHER, spring	7
8	V600246		STRAINER	1
9	V600247		'O' RING	1
10	V600248		BAFFLE, oil	1
11	V600249		BREATHER	1
12	V600250		PLUG	2
13	V600251		PLUG	1
14	V600252		TUBE, dipstick	1
15	V600253		DIPSTICK	1
20	-		ADAPTOR, male, part of item 22	2
21	V600254		VALVE, relief	1
22	V600488		FITTING, pipe	1
22A	V600489		PLUG	1
22B	V600490		'O' RING	1
23	41S06		WASHER, spring	6
24	69S04R		SCREW, set	6
26	V2003232		ADAPTOR, male	2
27	V600255		ADAPTOR, male/female	1

4C4000 & 4C5000 Dumper

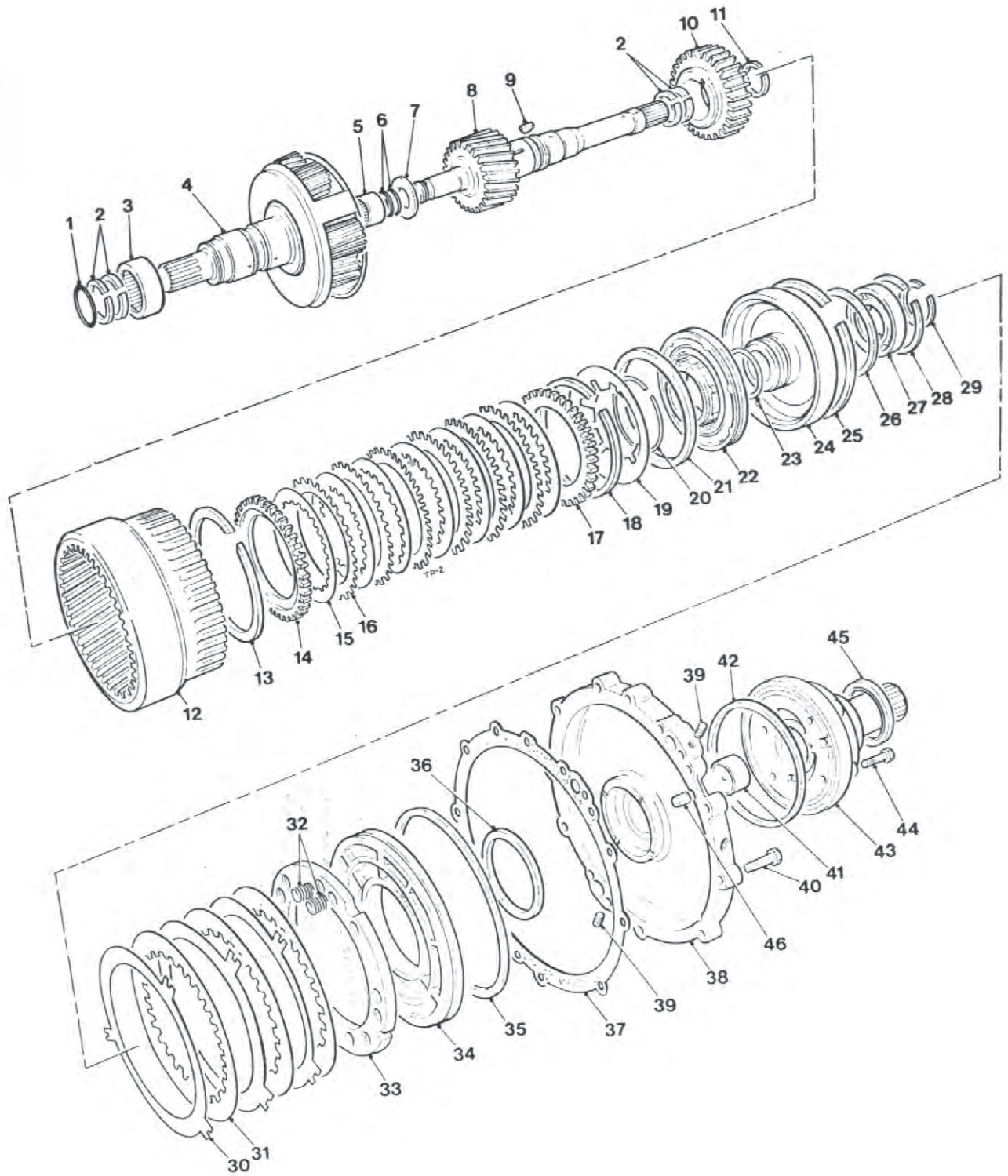

CLUTCHES & TORQUE CONVERTER PUMP

4 - C - 2

Item	Part no	Serial no	Description	Qty
1	V600259	AA01000/	'O' RING	1
2	V600260		SEAL RING	4
3	V600261		BEARING, needle	1
4	V600262		CARRIER & OUTPUT SHAFT	1
5	V600263		BEARING, needle	1
6	V600264		SEAL	2
7	V600265		WASHER, thrust	1
8	V600266		MAIN DRIVE GEAR SHAFT	1
9	V600267		KEY, woodruff	1
10	V600268		GEAR, forward clutch hub	1
11	V600269		RING, snap	1
12	V600270		GEAR, ring	1
13	V600271		RING, snap, .050 - .054", green	AR
13	V600272		RING, snap, .074 - .078", orange	AR
13	V600273		RING, snap, .096 - .100", white	AR
13	V600274		RING, snap, .062 - .066", pink	AR
14	V600275		PLATE, clutch, pressure	1
15	V600276		PLATE, driven, clutch, compound or	7
15	V600500		PLATE, driven, clutch, bronze	7
16	V600759		PLATE, separator, clutch, steel	6
17	V600277		PLATE, clutch pressure	1
18	V600278		RING, snap	1
19	V600279		SPRING, dished washer	1
20	V600280		BEARER RING	1
21	V600281		SEAL, outer, piston	1
22	V600282		PISTON	1
23	V600283		SEAL, inner, piston	1
24	V600284		CYLINDER, forward clutch	1
25	V600285		RING, snap, ring gear	1
26	V600286		WASHER, thrust, thin	AR
26	V600287		WASHER, thrust, thick	AR
27	V600288		BEARING	1
28	V600289		RING, snap	1
29	V600290		RING, snap	1
30	V600291		PLATE, separator, reverse clutch, steel	3
31	V600292		PLATE, driven, reverse clutch, compound	3
32	V600293		SPRING, reverse clutch	11
33	V600294		PLATE, pressure, reverse clutch	1
34	V600295		PISTON, reverse clutch	1
35	V600296		SEAL, outer, piston	1
36	V600297		SEAL, inner, piston	1
37	V600298		GASKET	1
38	V600299		PLATE, adaptor, forward & reverse	1
39	V600300		PLUG	2
40	V600301		SCREW, cap	4
41	V600302		BUSH (requires boring)	1
42	V600303		GASKET, pump	1
43	V600304		PUMP	1
44	V600305		BOLT, pump	4
45	V600306		SEAL, pump	1
46	V600307		DOWEL	3

4C4000 & 4C5000 Dumper

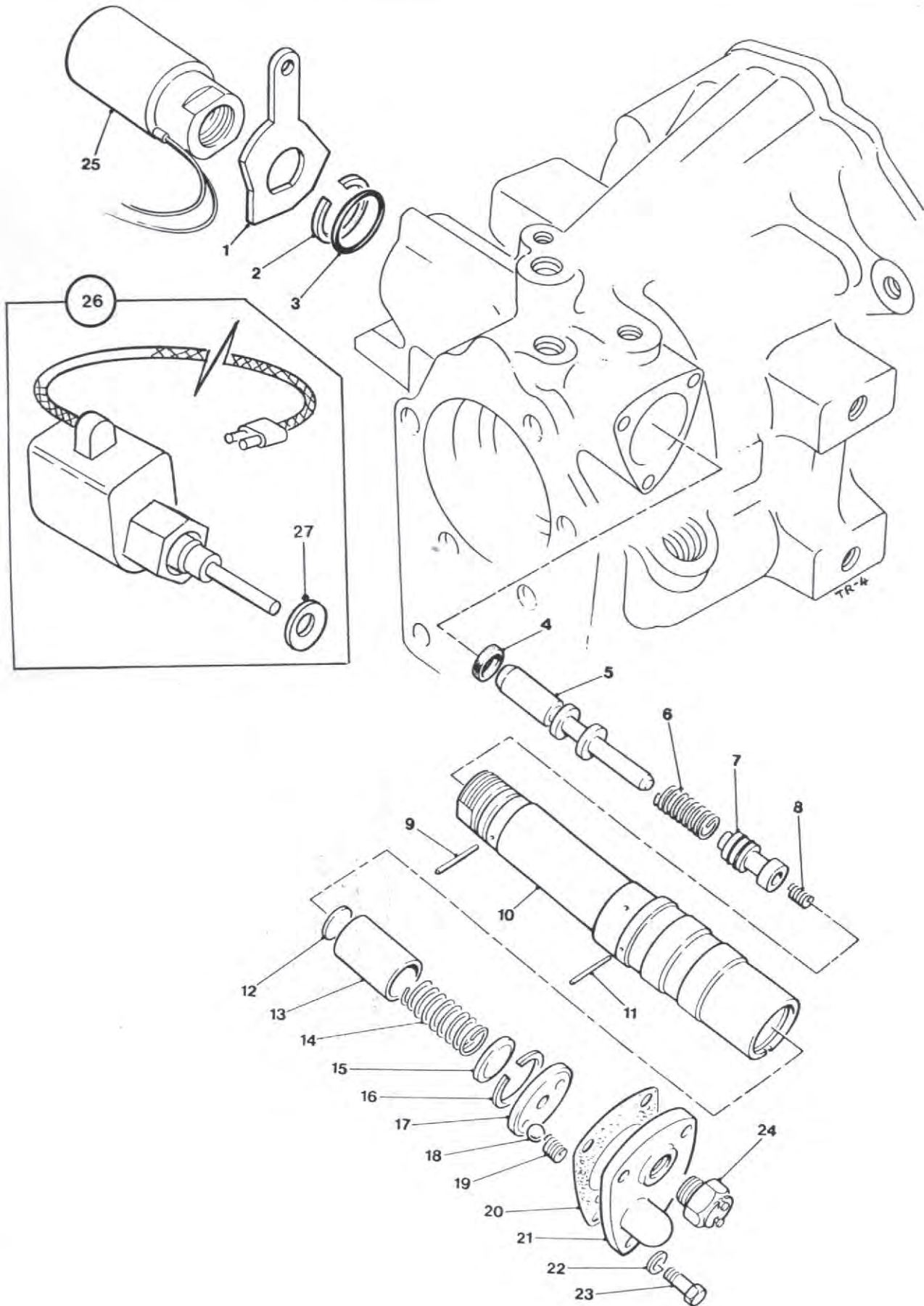

VALVE, FORWARD/NEUTRAL/REVERSE

4 - C - 3

Item	Part no	Serial no	Description	Qty
1	V2003260	AA01000/	PLATE, forward/neutral/reverse	1
2	V600308		RING, snap	1
3	V600309		+ 'O' RING	1
4	V600310		\$ SEAL, oil	1
-	V600415		VALVE, pressure relief, assembly	1
5	V600311		\$ PLUNGER	1
6	V600312		\$ SPRING, plunger	1
7	V600313		VALVE, dump	1
8	V600314		SPRING, dump valve	1
9	V600315		PIN	1
10	V600316		+ BODY, valve	1
11	V600317		PIN	1
12	V600318		PLUG, expansion	1
13	V600319		VALVE, regulator	1
14	V600320		SPRING, regulator valve	1
15	V600321		RETAINER, spring	1
16	V600322		RING, snap	1
17	V600323		CAM, switch	1
18	V600324		BALL, detent	1
19	V600325		SPRING, detent	1
20	V600326		GASKET	1
21	V600327		COVER	1
22	V600328		WASHER, spring	3
23	V600329		BOLT	3
24	-		SWITCH, c/w 'O' ring (see Electrical section)	1
25	-		SOLENOID (OBSOLETE: use V2003261)	1
26	V2003261		SOLENOID, assembly	1
27	V2003055		DISC, spring	1

+ NOTE: On later machines, item 10 (valve body, part number V600316) is fitted with 2 'O' rings (item 3, part number V600309).

\$ Items marked \$ are not required when V2003261 solenoid assembly.

4C4000 & 4C5000 Dumper

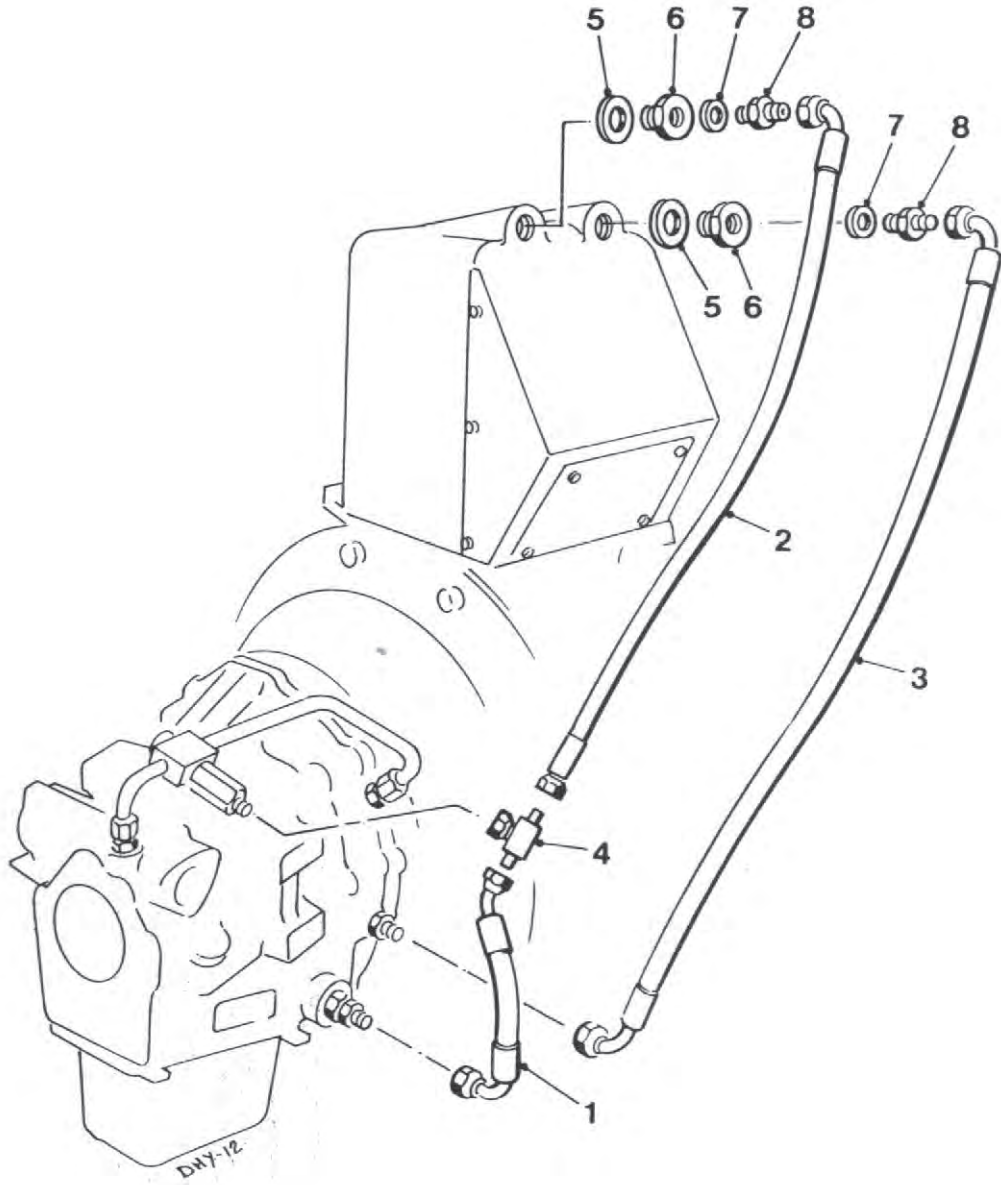

OIL COOLER, transmission**4 - C - 4**

Item	Part no	Serial no	Description	Qty
1	V2000280	AA01000/	HOSE	1
2	V2000277		HOSE	1
3	V2000278		HOSE	1
4	V2003217		ADAPTOR, tee	1
5	100S09		SEAL, bonded	2
6	V2000237		ADAPTOR	2
7	100S04		SEAL, bonded	2
8	V2003373		ADAPTOR	2

4C4000 & 4C5000 Dumper

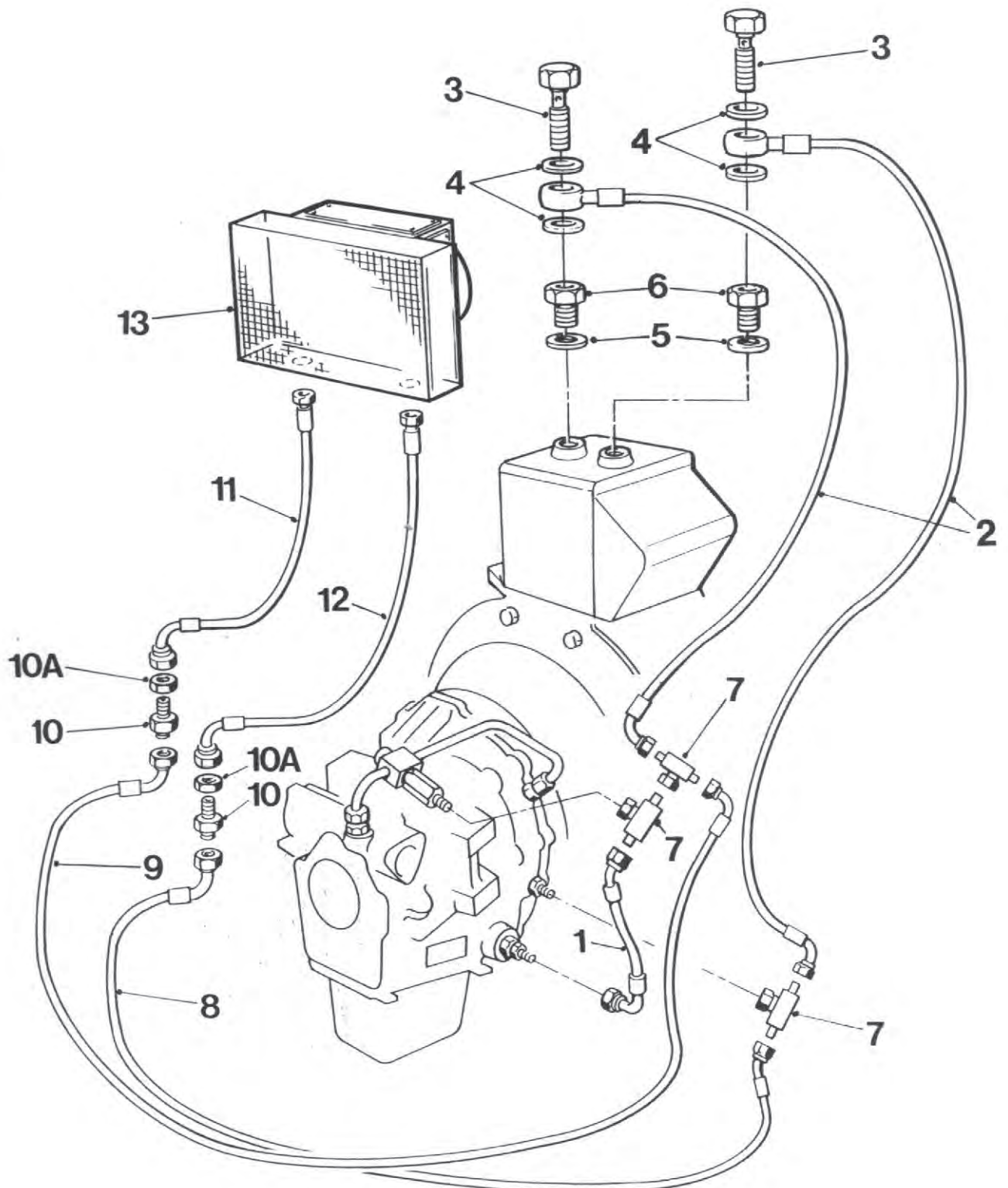

OIL COOLER, transmission / CAB HEATER circuits

4 - C - 4A

Item	Part no	Serial no	Description	Qty
1	V2000280	AK01087/	HOSE	1
2	V2001628		HOSE, assembly	2
3	V600145		BOLT, banjo	2
4	V600146		WASHER, copper	4
5	100S07		SEAL, bonded	2
6	V2001629		ADAPTOR	2
7	V2003217		ADAPTOR, tee	3
8	V2002257		HOSE	1
9	V2002256		HOSE	1
10	93S02		ADAPTOR, bulkhead	2
10A	72S02		NUT	2
11	V2002255		HOSE	1
12	V2002255		HOSE	1
13	V2001639		HEATER	1

4C4000 & 4C5000 Dumper

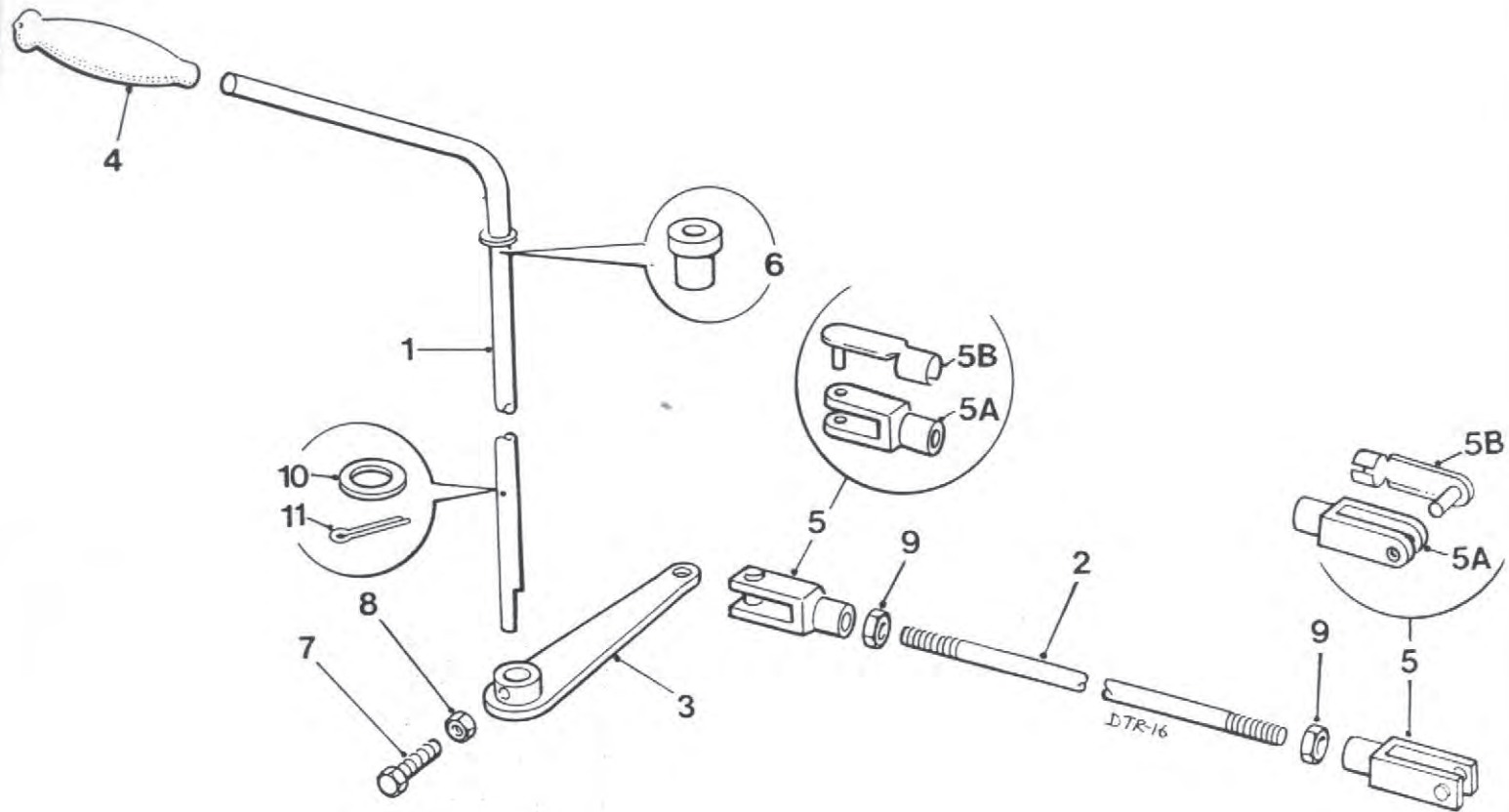

CONTROL LEVER, FORWARD/REVERSE

4 - C - 5

Item	Part no	Serial no	Description	Qty
-	V2000381	AA01000/	CONTROL LEVER, forward/reverse, assembly	1
1	V2000298		SELECTOR	1
2	V2000288		ROD	1
3	V2000286		ARM	1
4	V2003251		HANDGRIP	1
5	V2003191		CLEVIS, c/w pin (OBSOLETE: use V2003245 & V2003246)	2
5A	V2003245		CLEVIS	2
5B	V2003246		PIN, spring	2
6	V2003250		BUSH	1
7	11S03C		SCREW, set	1
8	7S03		NUT	1
9	7S02		NUT	2
10	44S02C		PIN, split	1
11	V2003212		WASHER, nylon	1

4C4000 & 4C5000 Dumper

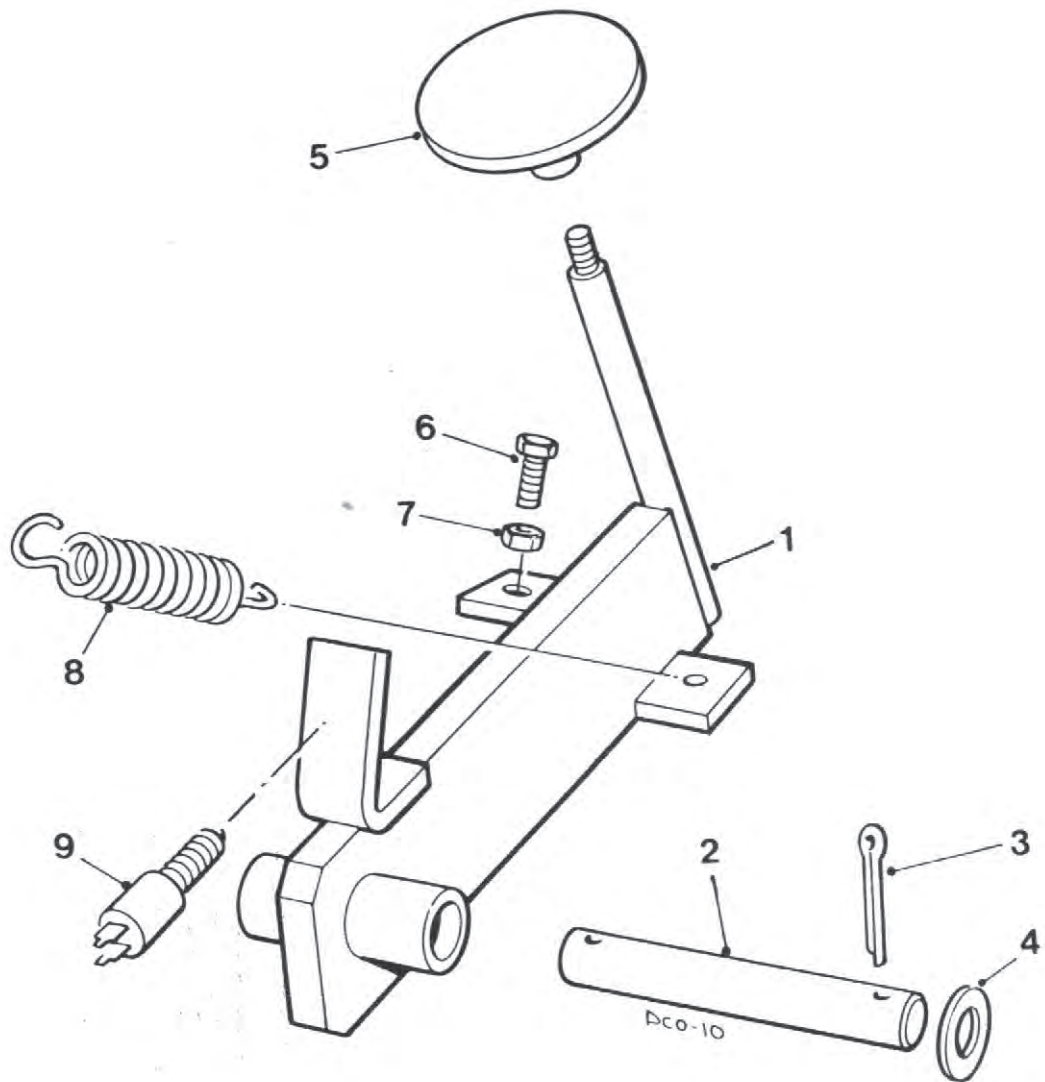

DUMP PEDAL, hydraulic transmission

4 - C - 6

Item	Part no	Serial no	Description	Qty
1	V2000345	AA01000/	PEDAL	1
2	V2000344	AA01000/	PIN	1
3	44S03C	AA01000/	PIN, split	2
4	267S07	AA01000/	WASHER, flat	2
5	V2000343	AA01000/	PAD, pedal	1
6	11S02G	AA01000/ BE01197	SCREW, set	1
6	11S02M	BE01198/	SCREW, set	1
7	56S11	AA01000/	NUT	1
8	C173B	AA01000/	SPRING	1
9	-	AA01000/	SWITCH (see Electrical Section)	1

4C4000 & 4C5000 Dumper

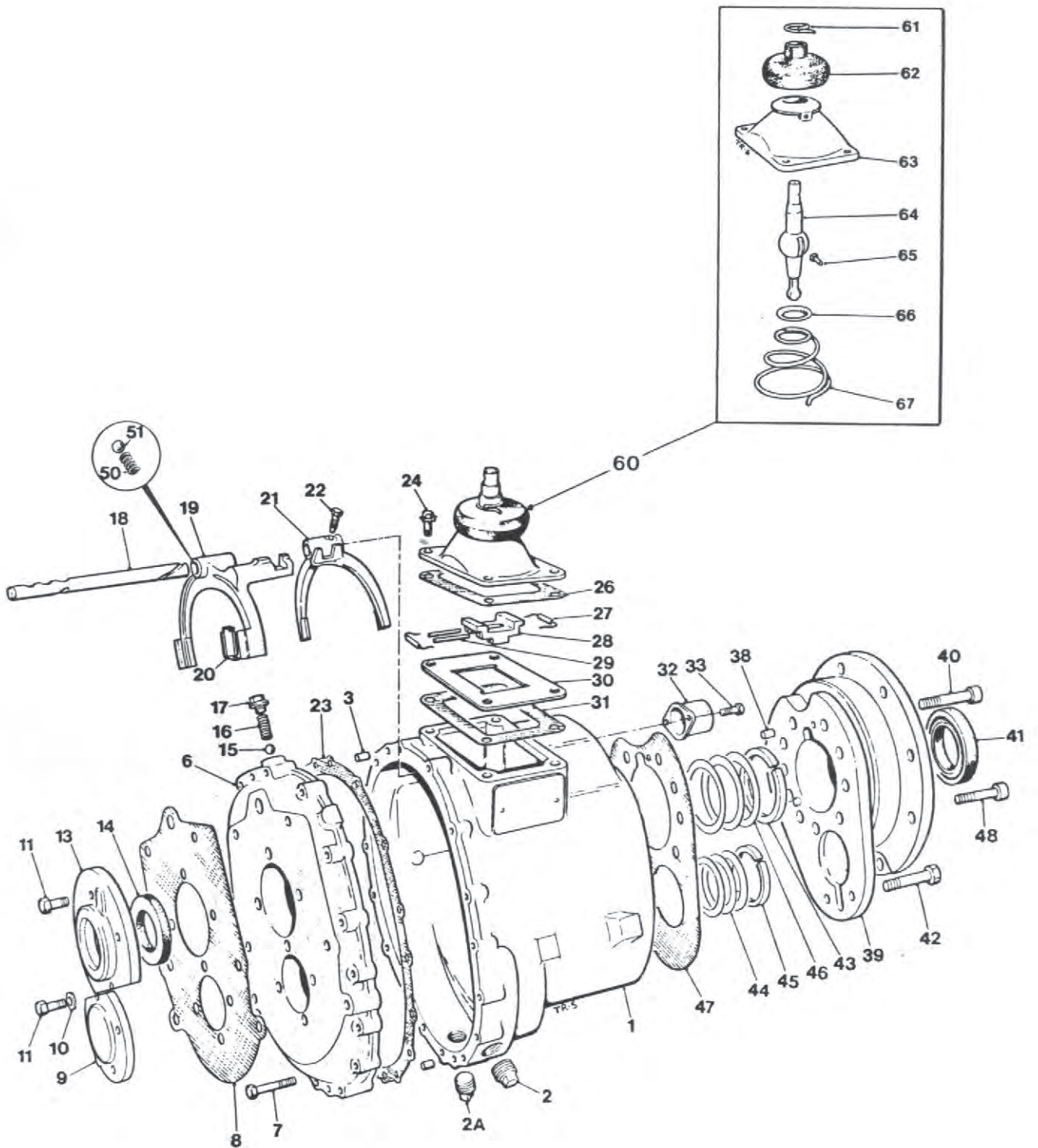

CASING, GEARBOX

4 - D - 1

Item	Part no	Serial no	Description	Qty
-	V600331	AA01000/	CASING, gearbox, assembly	1
1	V600332		CASING, gear, rear	1
2A	V600333		PLUG, oil drain	1
2	V600334		PLUG, oil filler/level	1
3	V600335		DOWEL	2
6	V600336		CASE, trans., front	1
7	V600337		SCREW, set	
8	V600338		GASKET	1
9	V600339		COVER	1
10	V600340		WASHER, flat	1
11	V600341		SCREW, set	7
13	V600342		HOUSING, seal	1
14	V600343		SEAL	1
15	V600344		BALL	1
16	V600345		SPRING, detent	1
17	V600346		PLUG	1
18	V600347		ROD, selector	1
-	V600348		FORK, 3rd/4th gear, assembly	1
19	-		FORK, 3rd/4th gear (order assembly)	1
20	V600349		SLIPPER, fork bushing	2
21	V600350		FORK, 1st/2nd gear	1
22	V600351		SCREW, locking	1
23	V600352		GASKET	1
24	V600353		BOLT & WASHER	4
26	V600355		GASKET	1
-	V600356		INTERLOCK MECH., assembly	1
27	V600357		CLIP	2
28	V600358		BLOCK, interlock	1
29	V600359		PIN, spirol	2
30	V600360		PLATE, support	1
31	V600355		GASKET	1
32	V600361		CAP, selector rod	1
33	V600362		SCREW, self tapping	2
38	V600335		DOWEL	2
39	V600363		ADAPTOR, transfer case	1
40	V600364		SCREW, cap	9
41	V600365		SEAL	1
42	V600353		SCREW, set	2
43	V600366		RING, spacer	1
44	V600367		SHIM, .002"	AR
44	V600368		SHIM, .003"	AR
44	V600369		SHIM, .005"	AR
44	V600370		SHIM, .007"	AR
44	V600371		SHIM, .015"	AR
44	V600372		SHIM, .020"	AR
45	V600409		RING, spacer	1
46	V600373		SHIM, .002"	AR
46	V600374		SHIM, .003"	AR

continued>

4C4000 & 4C5000 Dumper

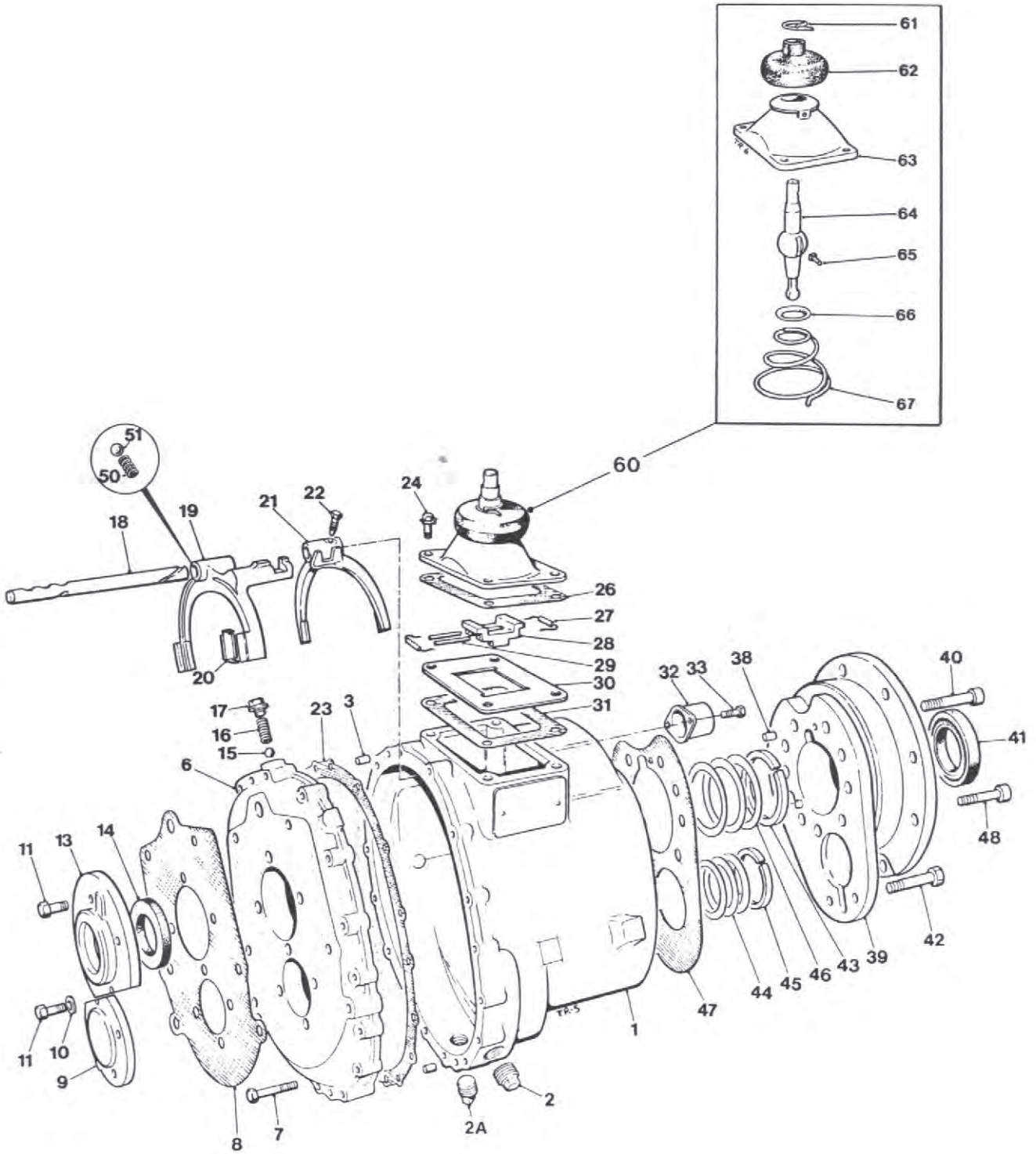

CASING, GEARBOX

4 - D - 1

Item	Part no	Serial no	Description	Qty
46	V600375	AA01000/	SHIM, .005"	AR
46	V600376		SHIM, .007"	AR
46	V600377		SHIM, .015"	AR
46	V600378		SHIM, .020"	AR
47	V600379		GASKET	1
48	V600380		SCREW, cap	1
50	V600410		SPRING, detent	1
51	V600344		BALL	1
60	V600354		GEAR SELECTOR CONTROL, assembly	1
61	V600381		CLIP	1
62	V600382		COVER, dust	1
63	V600383		HOUSING, control	1
64	V600384		LEVER, stub, gear select	1
65	V600385		PIN, lever	1
66	V600386		WASHER	1
67	V600387		SPRING, support	1

4C4000 & 4C5000 Dumper

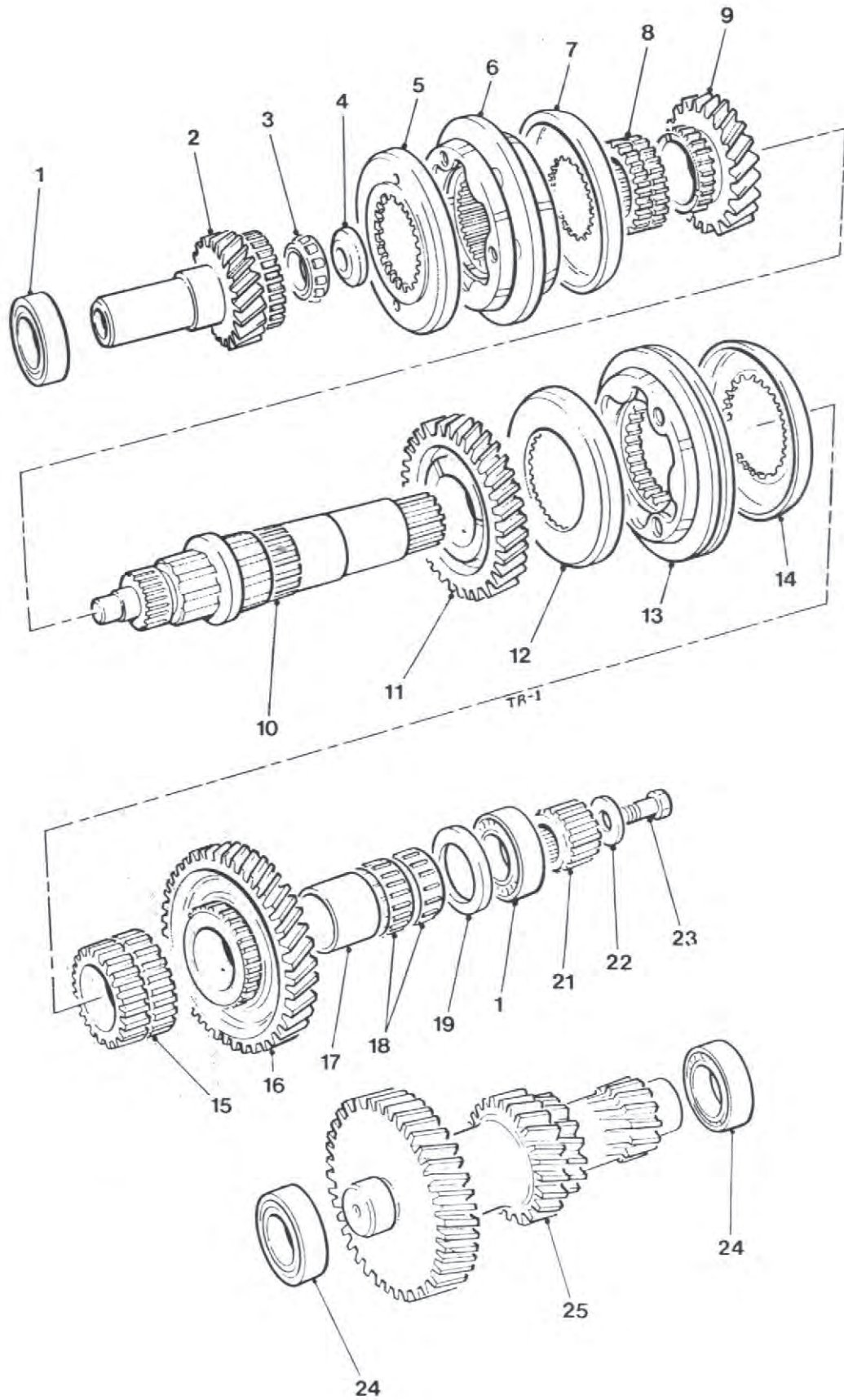

GEARS & SHAFTS

4 - D - 2

Item	Part no	Serial no	Description	Qty
1	V600388	AA01000/	BEARING, conical	2
2	V600389		GEAR, 19T, maindrive	1
3	V600390		BEARING, conical	1
4	V600391		WASHER, thrust	1
-	V600392		SYNCHRO, 3rd/4th, assembly	1
5	-		CUP, 4th speed synchro (order assembly)	1
6	-		SYNCHRO, 3rd/4th (order assembly)	1
7	-		CUP, 3rd speed synchro (order assembly)	1
8	V600393		HUB SLEEVE, 3rd/4th gear	1
9	V600394		GEAR, 3rd, 28T, mainshaft	1
10	V600395		SHAFT, main	1
11	V600396		GEAR, 2nd, 35T, mainshaft	1
-	V600397		SYNCHRO, 1st/2nd, assembly	1
12	-		CUP, 2nd speed synchro (order assembly)	1
13	-		SYNCHRO, 1st/2nd (order assembly)	1
14	-		CUP, 1st speed synchro (order assembly)	1
15	V600398		HUB SLEEVE, 1st/2nd gear	1
16	V600399		GEAR, 1st, 41T, mainshaft	1
17	V600400		SLEEVE, bearing, needle	1
18	V600401		BEARING, needle	2
19	V600402		WASHER, thrust	1
21	V600403		COUPLING	1
22	V600404		WASHER, flat	1
23	V600405		SCREW	1
24	V600406		BEARING, conical	2
25	V600407		SHAFT, counter	1

4C4000 & 4C5000 Dumper

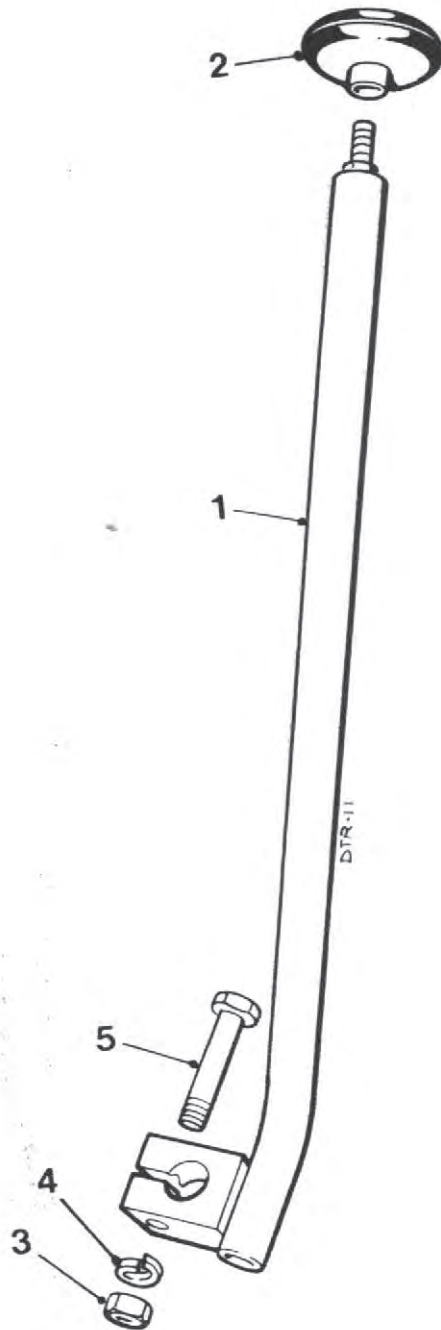

GEAR LEVER

4 - D - 3

Item	Part no	Serial no	Description	Qty
1	V2000285	AA01000/	LEVER	1
2	V2000347		KNOB	1
3	7S04		NUT	1
4	17S05		WASHER, spring	1
5	8S04J		BOLT	1

4C4000 & 4C5000 Dumper

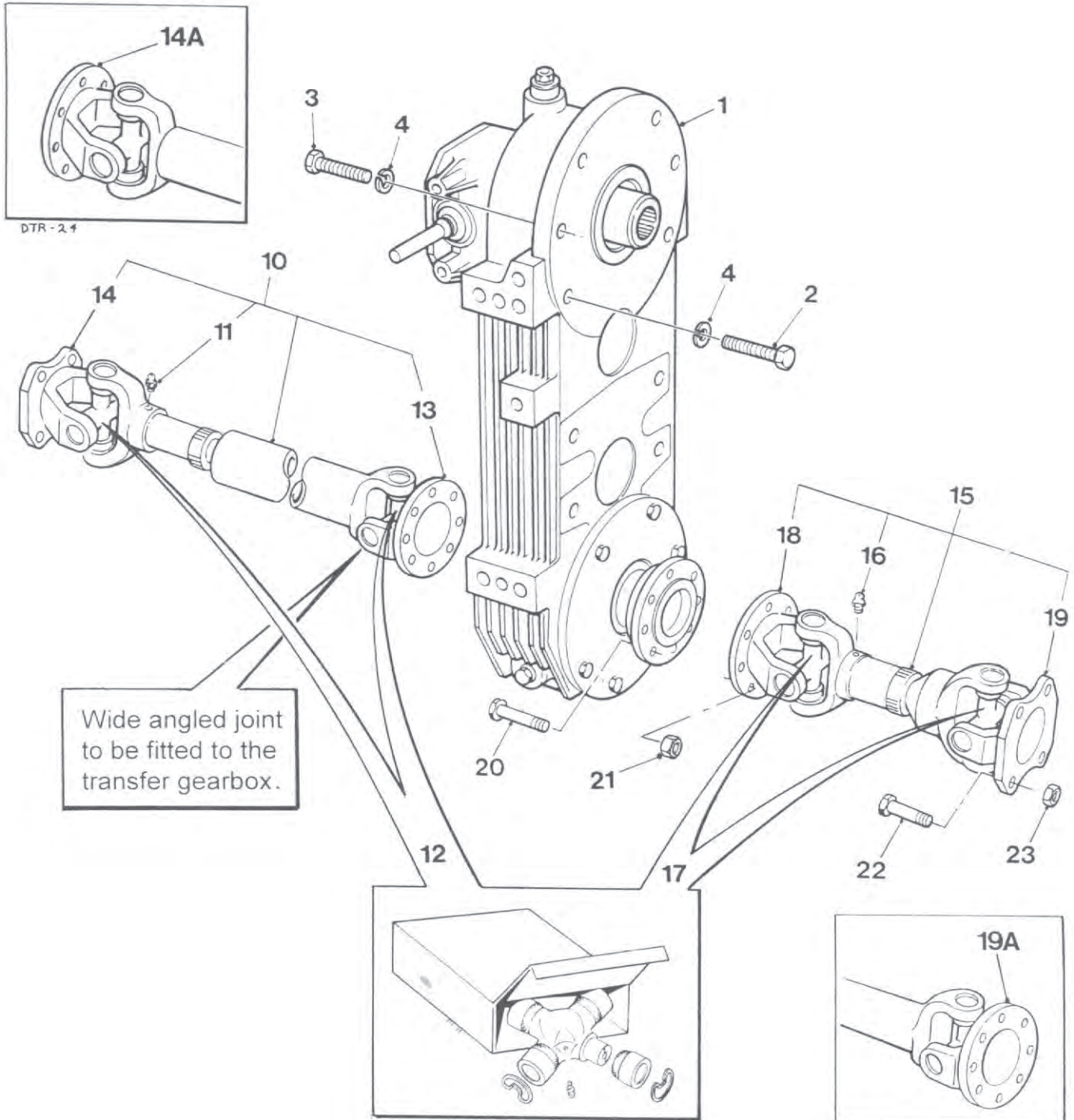

PROPELLER SHAFTS & TRANSFER GEARBOX

4 - E - 1

Item	Part no	Serial no	Description	Qty
1	-	AA01000/	TRANSFER GEARBOX (see page 4 - F - 1)	1
2	11S13E	AA01000/	SCREW, set	2
3	11S13G	AA01000/	SCREW, set	4
4	17S07	AA01000/	WASHER, spring	6
10	V2000313	AA01000/ BC01185	PROPELLER SHAFT, front, assembly	1
10	V2000920	BC01186/	+ PROPELLER SHAFT, front, assembly	1
11	V2003181	AA01000/	NIPPLE, grease	3
12	10207A01	AA01000/ BC01185	KIT, repair, universal joint	AR
13	V600413	AA01000/	FLANGE, mounting	1
14	V600478	AA01000/ BC01185	FLANGE, mounting	1
14A	V600413	BC01186/	FLANGE, mounting	1
15	V2000314	AA01000/ BC01185	PROPELLER SHAFT, rear, assembly	1
15	V2000921	BC01186/	+ PROPELLER SHAFT, rear, assembly	1
16	V2003181	AA01000/	NIPPLE, grease	3
17	10207A01	AA01000/ BC01185	KIT, repair, universal joint	AR
18	V600413	AA01000/	FLANGE, mounting	1
19	V600478	AA01000/ BC01185	FLANGE, mounting	1
19A	V600413	BC01186/	FLANGE, mounting	1
20	10365A02	AA01000/	BOLT	16
21	87S03	AA01000/	NUT, nylon insert	16
22	ESE214	AA01000/ BC01185	BOLT	8
22	10365A02	BC01186/	BOLT	16
23	87S04	AA01000/ BC01185	NUT, self locking	8
23	87S03	BC01186/	NUT, nylon insert	16
17	10307A01	BC01186/	+ KIT, repair, universal joint	AR

4C4000 & 4C5000 Dumper

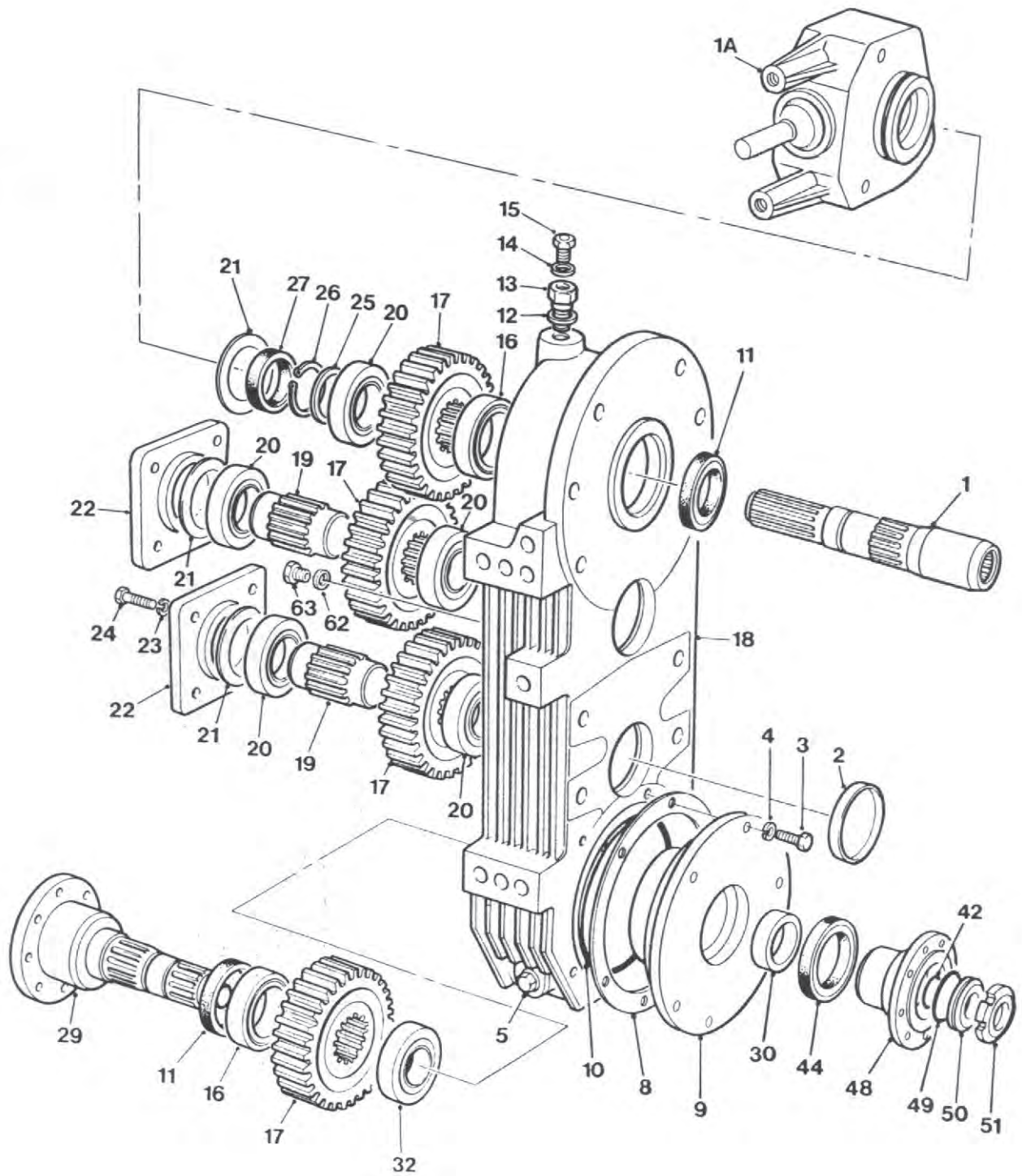

TRANSFER GEARBOX

4 - F - 1

Item	Part no	Serial no	Description	Qty
-	V2000169	AA01000/	TRANSFER GEARBOX, c/w brake, assembly	1
1	V600459		SHAFT, input	1
1A	-		BRAKE (see Brake Section)	1
2	V600420		PLUG	2
3	8S04B		BOLT	5
4	V600421		WASHER, spring	9
5	V600197		PLUG, oil drain, magnetic	1
8	V600452		SHIM, 0.10mm	AR
8	V600453		SHIM, 0.19mm	AR
8	V600454		SHIM, 0.35mm	AR
9	V600013		COVER, transfer gearbox	1
10	V600439		'O' RING	1
11	V600434		SEAL, oil	2
12	235S11		WASHER, copper	1
13	V600457		EXTENSION	1
14	235S06		WASHER, copper	1
15	V600440		PLUG, breather	1
16	V600435		BEARING	2
17	V600458		GEAR	4
18	V600460		HOUSING	1
19	V600456		SHAFT	2
20	V600479		BEARING	5
21	V600443		SHIM, 0.1mm	AR
21	V600442		SHIM, 0.3mm	AR
21	V600444		SHIM, 0.5mm	AR
22	V600455		COVER	2
23	V600419		WASHER, spring	8
24	8S03A		BOLT	8
25	V600445		WASHER, thrust	1
26	V600422		CIRCLIP	1
27	V600433		SEAL, oil	1
29	V600014		FLANGE/SHAFT	1
30	V600015		SPACER	1
32	119245000		BEARING	1
42	V600436		'O' RING	1
44	V600432		SEAL, oil	1
48	V600016		FLANGE	1
49	V600438		'O' RING	1
50	V600449		RING, centralising	1
51	V600431		NUT, ring	1
62	235S05		WASHER, copper	1
63	V600441		PLUG, oil level	1
-	V600450		PLATE, serial number	1

4C4000 & 4C5000 Dumper

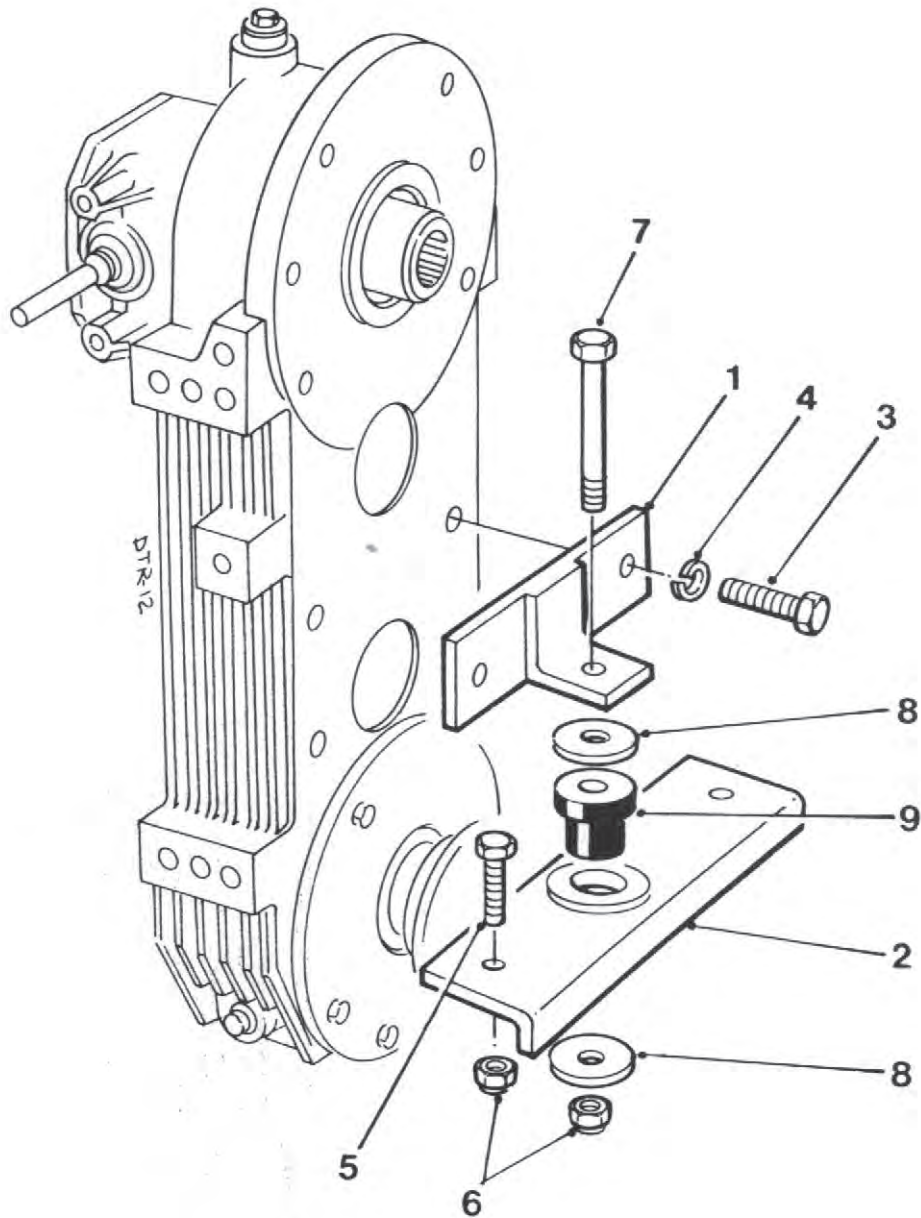

MOUNTING, transfer gearbox**4 - F - 2**

Item	Part no	Serial no	Description	Qty
1	V2000341	AA01000/	BRACKET	1
2	V2000336		BRACKET	1
3	11S06C		SCREW, set	2
4	17S08		WASHER, spring	2
5	11S05F		SCREW, set	2
6	59S04		NUT, nylon insert	3
7	8S05M		BOLT	1
8	V2003218		WASHER, special	2
9	V2003216		MOUNTING, flexible	1

ELECTRICS

For engine electrics, see:
"Engine Parts Catalogue"

5 - A - 1	LOOMS
5 - A - 1A	LOOMS
5 - A - 2	INSTRUMENT PANEL
5 - A - 3	BATTERY & LEADS
5 - L - 1	FLASHING BEACON
5 - W - 1	WIPER, front screen
5 - W - 2	WIPER, rear screen

4C4000 & 4C5000 Dumper

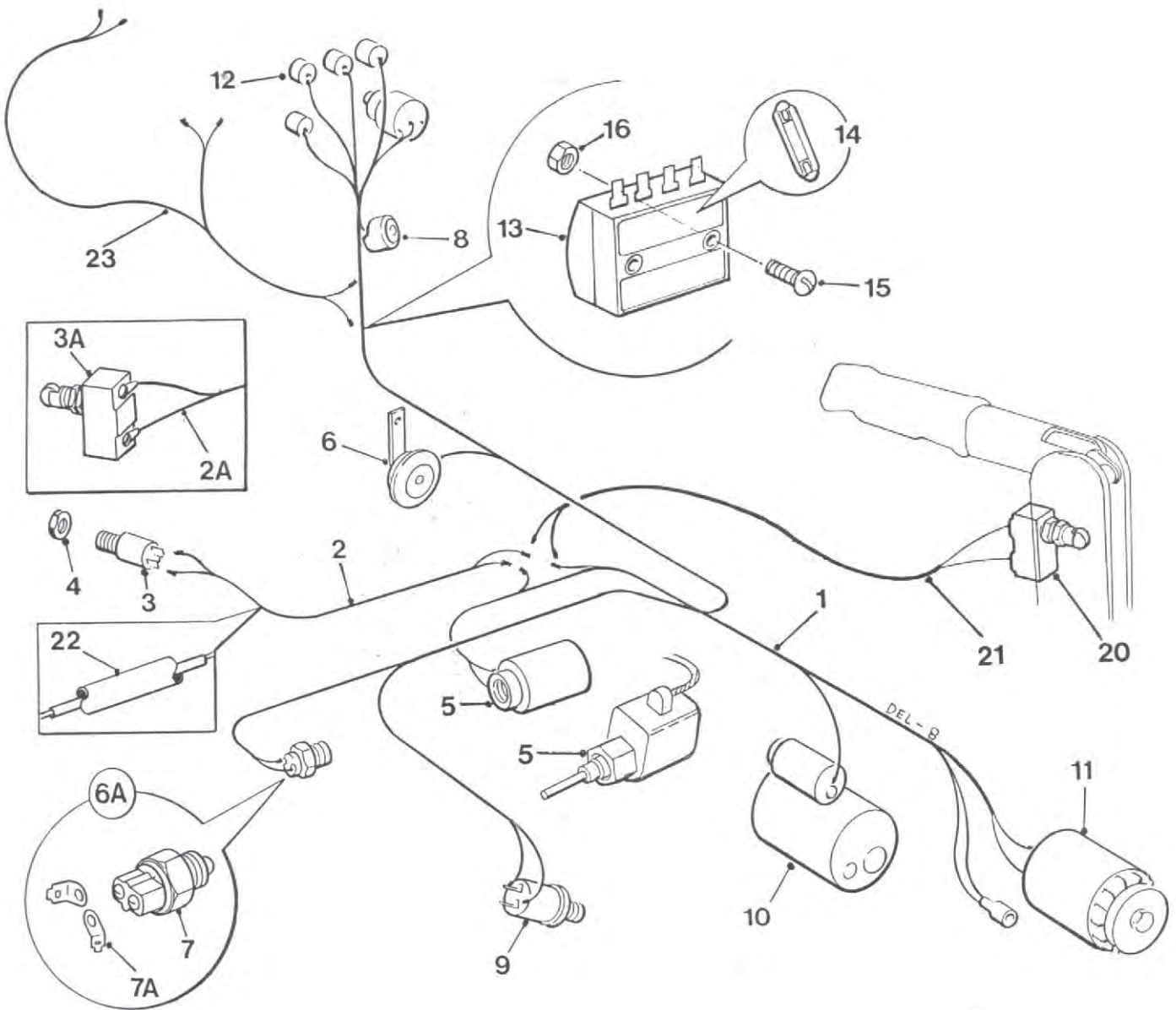
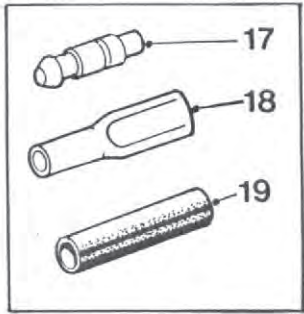

LOOMS

5 - A - 1

Item	Part no	Serial no	Description	Qty
1	V2000283	AA01000/	LOOM, frame	1
2	V2003262	AA01000/BE01197	LOOM, dump switch	1
2A	V2000937	BE01198/	LOOM, dump pedal	1
3	V2003168	AA01000/BE01197	SWITCH, dump	1
3A	V2003249	BE01198/	SWITCH, dump	1
4	V2003178	AA01000/BE01197	NUT	1
5	-	AA01000/	SOLENOID, hydraulic transmission (see page 4 - C - 3)	1
6	V2003144	AA01000/	HORN	1
6A	V600147	AA01000/	CONNECTOR & SWITCH, assembly	1
7	V600330	AA01000/	SWITCH, c/w 'O' ring, hydraulic trans.	1
7A	V2003239	AA01000/	CONNECTOR	2
8	V2000402	AA01000/	AUDIBLE ALARM	1
9	-	AA01000/	* SWITCH, oil pressure	
10	-	AA01000/	* STARTER MOTOR	
11	-	AA01000/	* ALTERNATOR	
12	-	AA01000/	INSTRUMENT PANEL (see page 5 - A - 2)	
13	V2003176	AE01019/	FUSE BOX	1
14	V2003177	AE01019/	FUSE, 8amp	4
15	200S09C	AE01019/	SCREW	2
16	104S15	AE01019/	NUT	2
17	V2003192	AA01000/	BULLET CONNECTOR	1
18	V2003233	AA01000/	TERMINAL, female	1
19	V2003173	AA01000/	CONNECTOR	1
20	V2003249	BE01198/AJ01296	SWITCH, dump	1
20	-	AJ01297/	SWITCH, dump (see page 5 - A - 1A)	1
21	V2000937	BE01198/AJ01296	LOOM, dump, parking brake	1
21	-	AJ01297/	LOOM, dump, parking brake (see page 5 - A - 1A)	1
22	208106050	AA01000/	SLEEVE, pvc	AR
23	V2002140	AK01087/	LOOM, cab	1

* see: "Engine Parts Catalogue"

4C4000 & 4C5000 Dumper

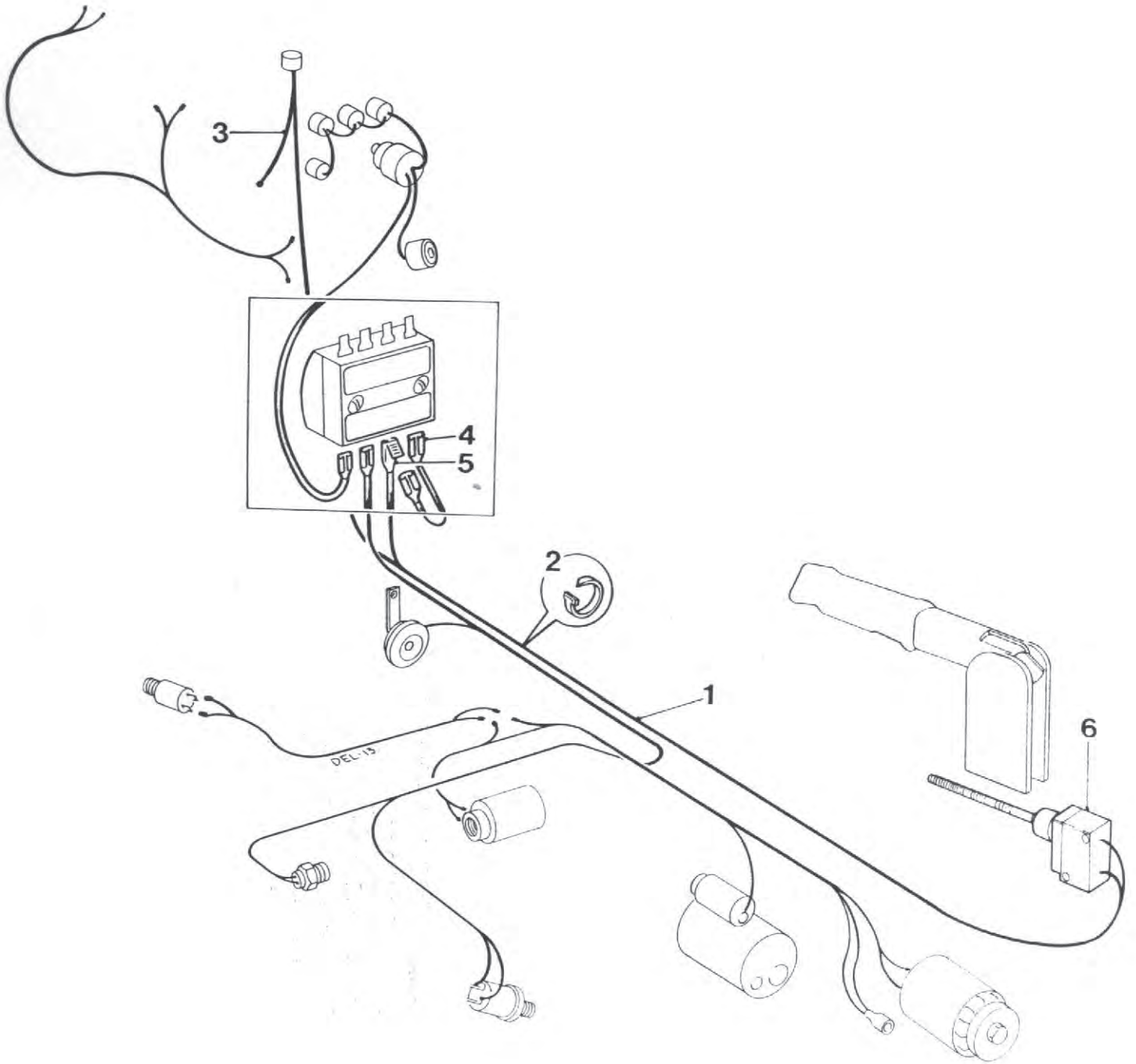

LOOMS**5 - A - 1A**

Item	Part no	Serial no	Description	Qty
1	V2002551	AJ01297/	LOOM, dump, parking brake	1
2	V2003166	AJ01297/	TIE, cable	6
3	V2002553	AJ01297/	CABLE, earth	1
4	V2003233	AJ01297/	TERMINAL, female	AR
5	V2003172	AJ01297/	TERMINAL, twin	AR
6	V2003244	AJ01297/	SWITCH, dump	1

4C4000 & 4C5000 Dumper

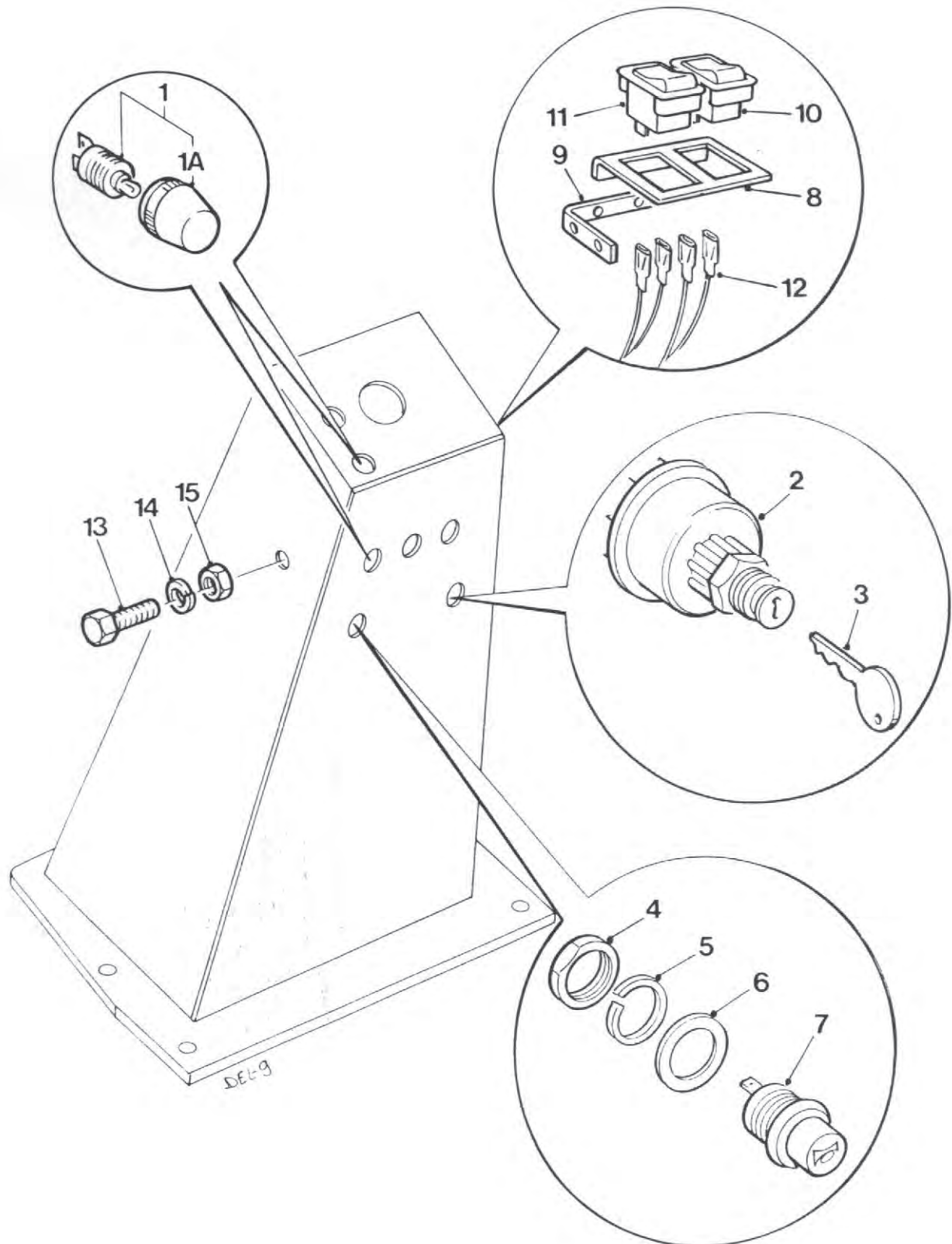

INSTRUMENT PANEL

5 - A - 2

Item	Part no	Serial no	Description	Qty
1	V2000326	AA01000/	LIGHT, warning, assembly	4
1A	V600148	AA01000/	LENS	1
2	V600411	AA01000/	SWITCH, START, assembly	1
3	V600414	AA01000/	KEY, start switch, key no. 92274	1
4	V600426	AA01000/	NUT	1
5	V600428	AA01000/	WASHER, spring	1
6	V600429	AA01000/	WASHER, flat	1
7	V600427	AA01000/	BUTTON, horn, push	1
Machines with cabs only				
8	V2003208	AK01087/	BRACKET, switches	1
9	V2002137	AK01087/	BRACKET, mounting	1
10	V2003194	AK01087/	SWITCH, screen washer	1
11	V2003196	AK01087/	SWITCH, heater	1
12	-	AK01087/	LOOM, cab (see page 5 - A - 1)	1
13	11S01A	JAN 90/	SCREW, set	1
14	17S02	JAN 90/	WASHER, spring	1
15	7S01	JAN 90/	NUT	1

4C4000 & 4C5000 Dumper

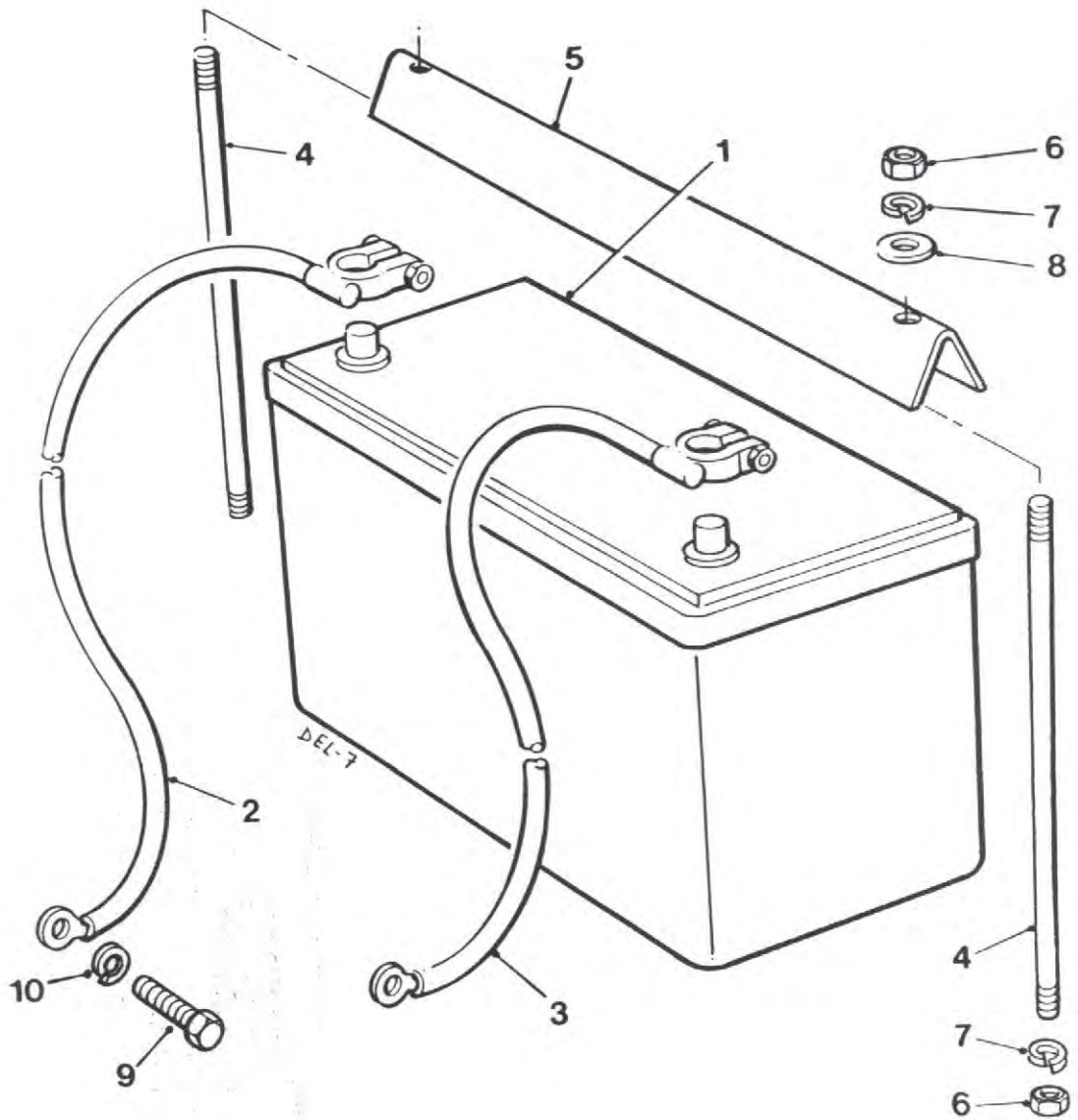

BATTERY & LEADS**5 - A - 3**

Item	Part no	Serial no	Description	Qty
1	V2003224	AA01000/	BATTERY	1
2	10990A06		LEAD, battery, negative	1
3	V2000284		LEAD, battery, positive	1
4	V2000291		ROD	2
5	V2000292		CLAMP	1
6	7S02		NUT	4
7	17S03		WASHER, spring	4
8	267S04		WASHER, flat	2
9	11S04B		SCREW, set	1
10	17S05		WASHER, spring	1

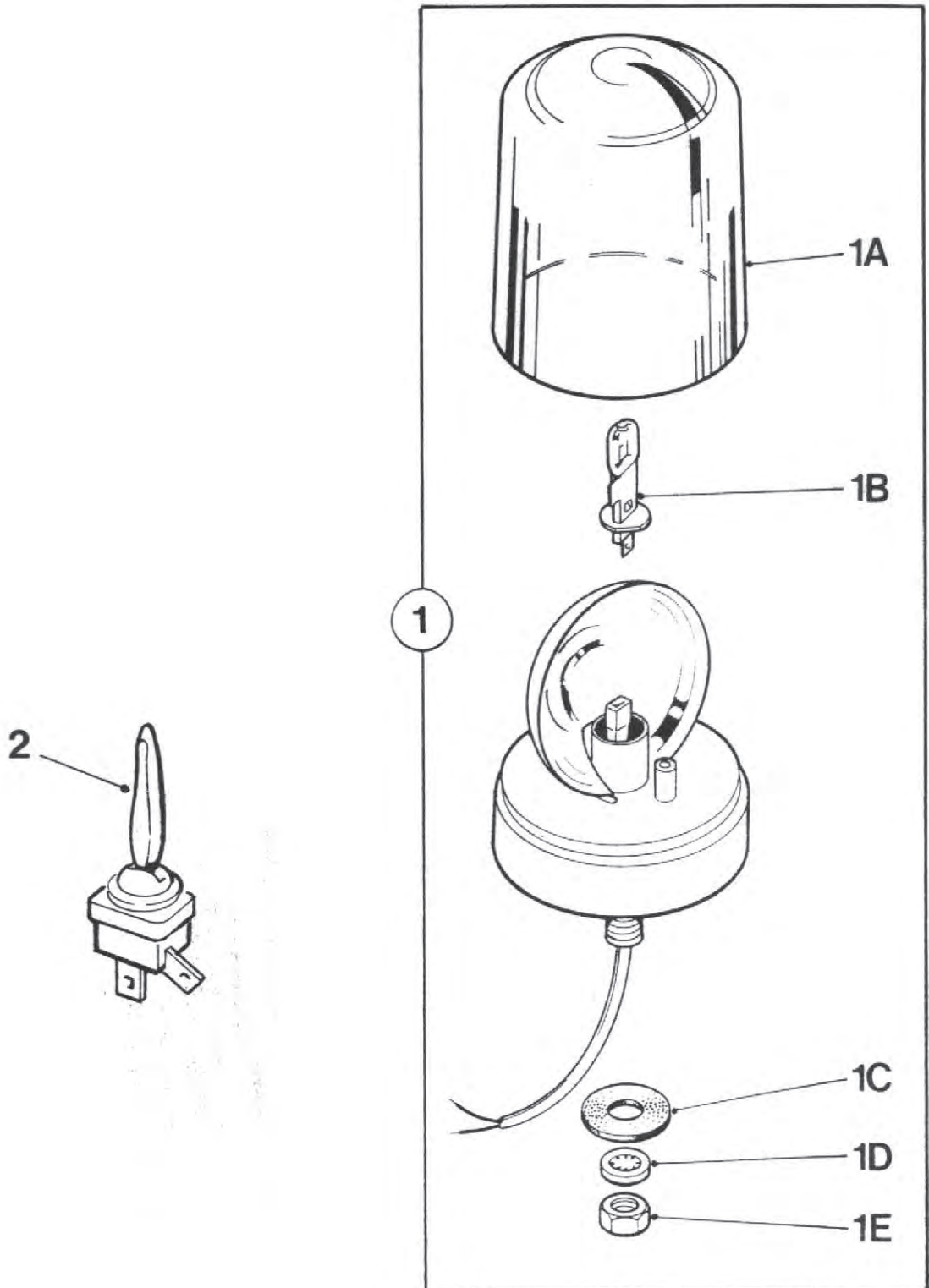

EL-94

FLASHING BEACON

5 - L - 1

Item	Part no	Serial no	Description	Qty
1	V2003193	AK01087/	BEACON, assembly	1
1A	V600492		LENS, beacon	1
1B	V600430		BULB, beacon	1
1C	-		GASKET, rubber (order assembly)	1
1D	13S05		WASHER, shakeproof	1
1E	7S05		NUT	1
2	V2003197		SWITCH	1
-	-		LOOM (see page 5 - A - 1)	

4C4000 & 4C5000 Dumper

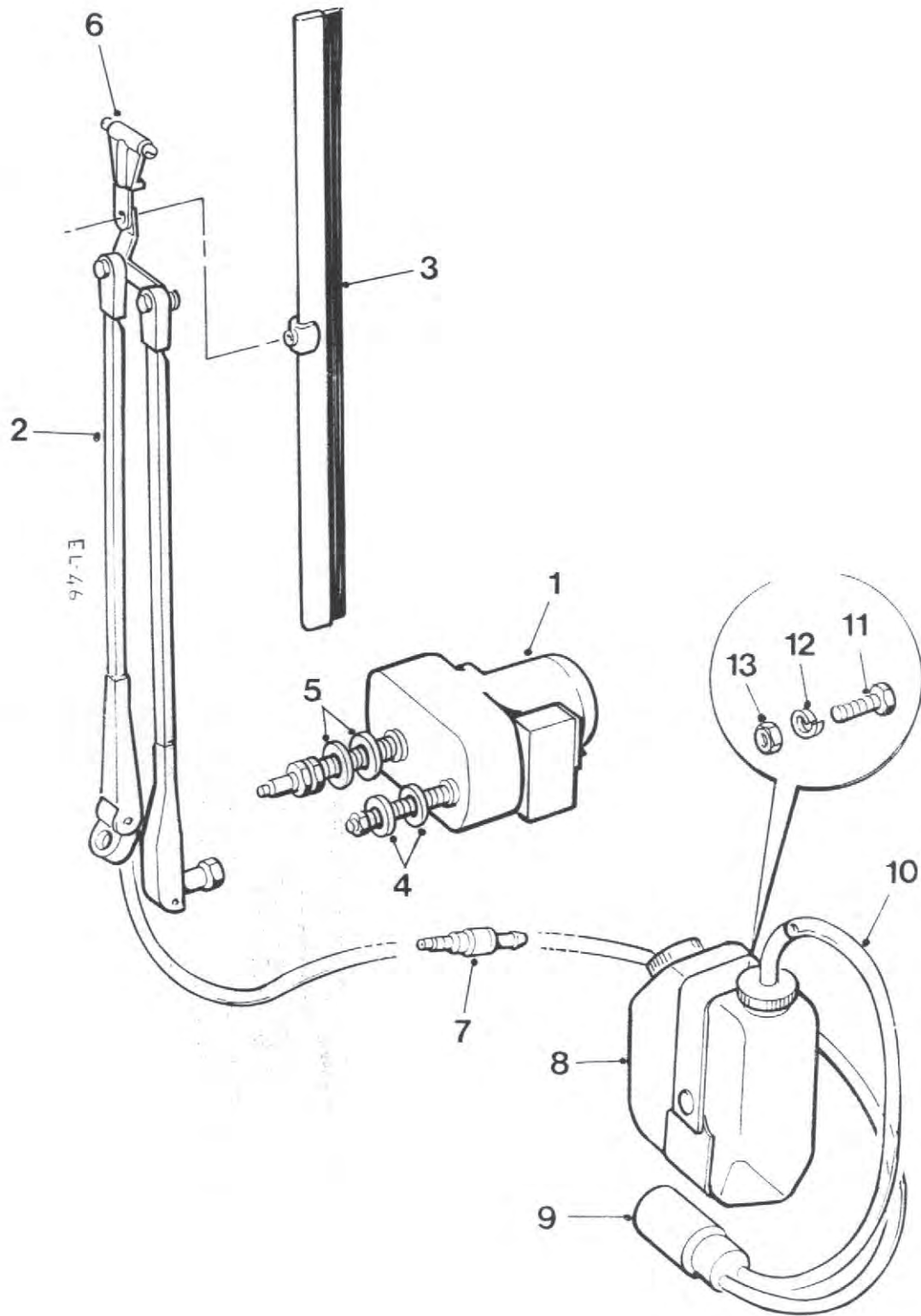

WIPER, front screen

5 - W - 1

Item	Part no	Serial no	Description	Qty
1	V2003227	AK01087/	MOTOR	1
2	V2003226		GUIDE, wiper	1
3	V2003207		BLADE, wiper	1
4	V2003211		WASHER, nylon	2
5	V2003212		WASHER, nylon	2
6	V2003198		NOZZLE	1
7	V2003195		VALVE, non return	1
8	V2003213		RESERVOIR, washer	1
9	V2003214		PUMP, reservoir	1
10	V2003189		HOSE (order by metre)	AR
11	11S01AA		SCREW, set	4
12	17S02		WASHER, spring	4
13	7S01		NUT	2

4C4000 & 4C5000 Dumper

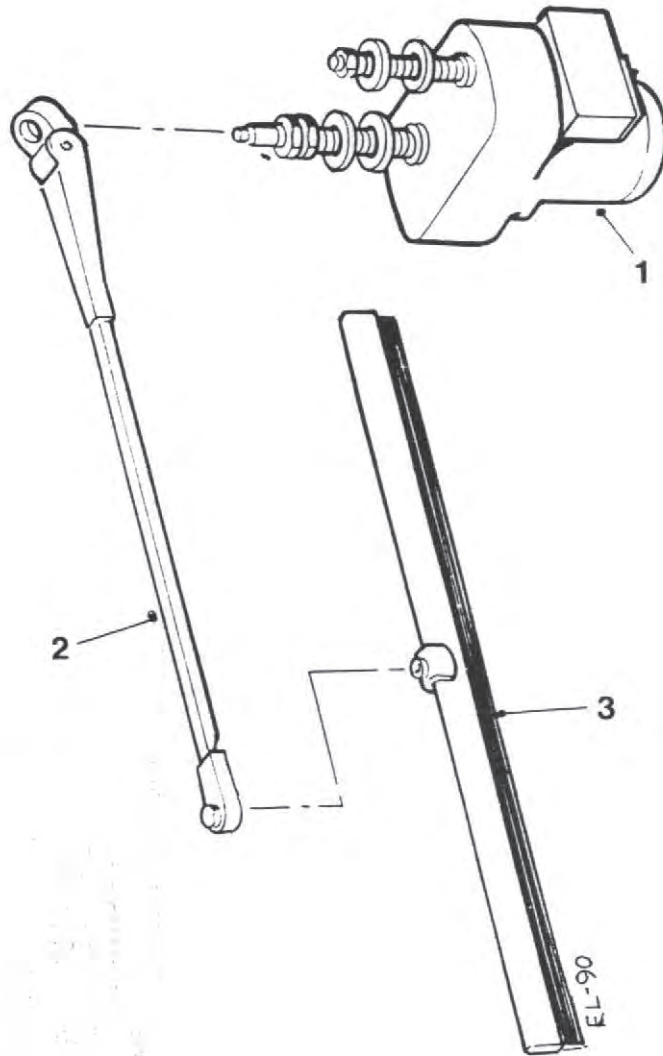

WIPER, rear screen

5 - W - 2

Item	Part no	Serial no	Description	Qty
1	V2003227	AK01087/	MOTOR, wiper	1
2	V2003243		ARM, wiper	1
3	V2003169		BLADE, wiper	1

SKIP

6 - A - 1 SKIP

6
A
1

4C4000 & 4C5000 Dumper

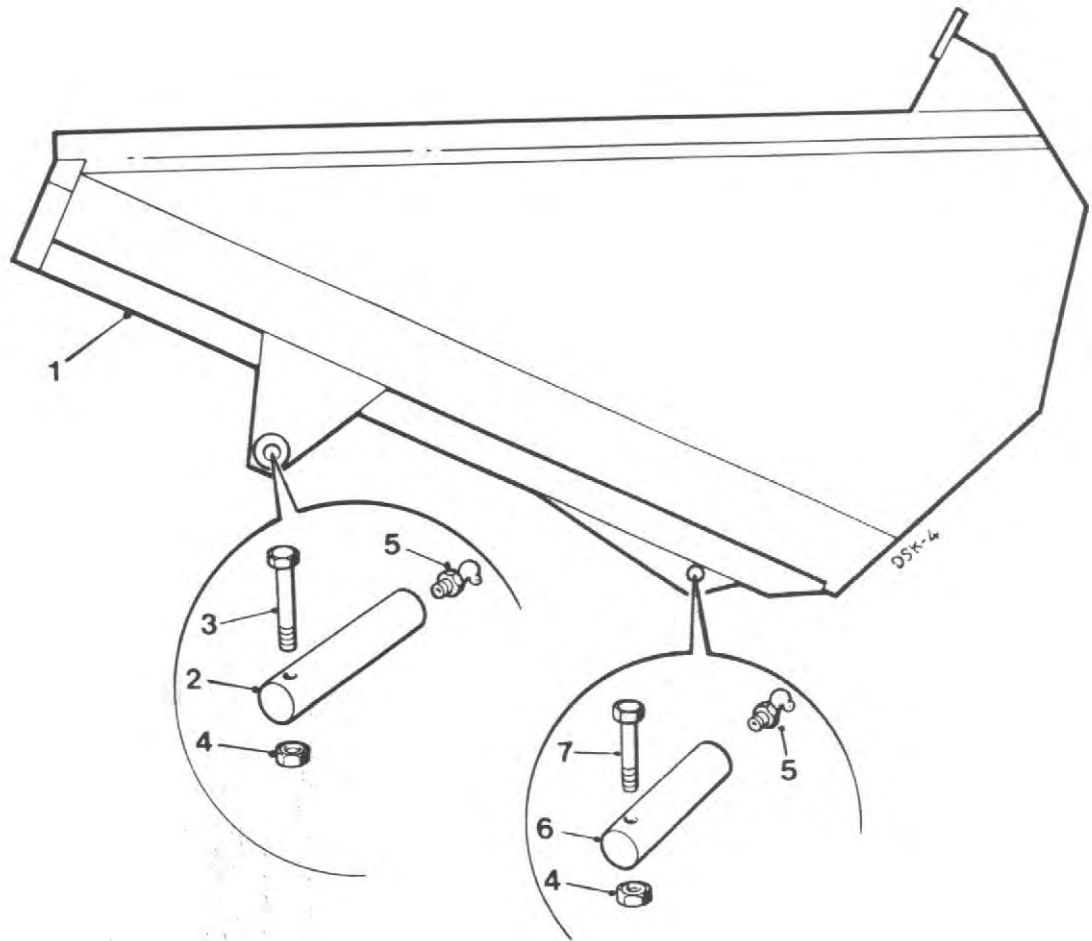

SKIP

6 - A - 1

Item	Part no	Serial no	Description	Qty
1	V2000323	AA01000/	SKIP, 4C4000	1
1	V2001655	BA011111/	SKIP, 4C5000	1
2	V2000230		PIN, skip pivot	2
3	8S03L		BOLT	2
4	59S12		NUT, nylon insert	4
5	131S02		NIPPLE, grease	4
6	V2000231		PIN, ram	2
7	8S03L		BOLT	2

HYDRAULICS

7 - A - 1 MAIN HYDRAULIC CIRCUIT

7 - B - 1 TIPPING HYDRAULIC CIRCUIT

7 - C - 1 CONTROL VALVE, HYDRAULIC

7 - C - 2 CONTROL VALVE SECTION

7 - R - 1 RAM, HYDRAULIC, TIPPING

7 - R - 2 RAM, STEERING, to machine serial no.
BF01243

7 - R - 3 RAM, STEERING, from machine serial no.
BF01244

4C4000 & 4C5000 Dumper

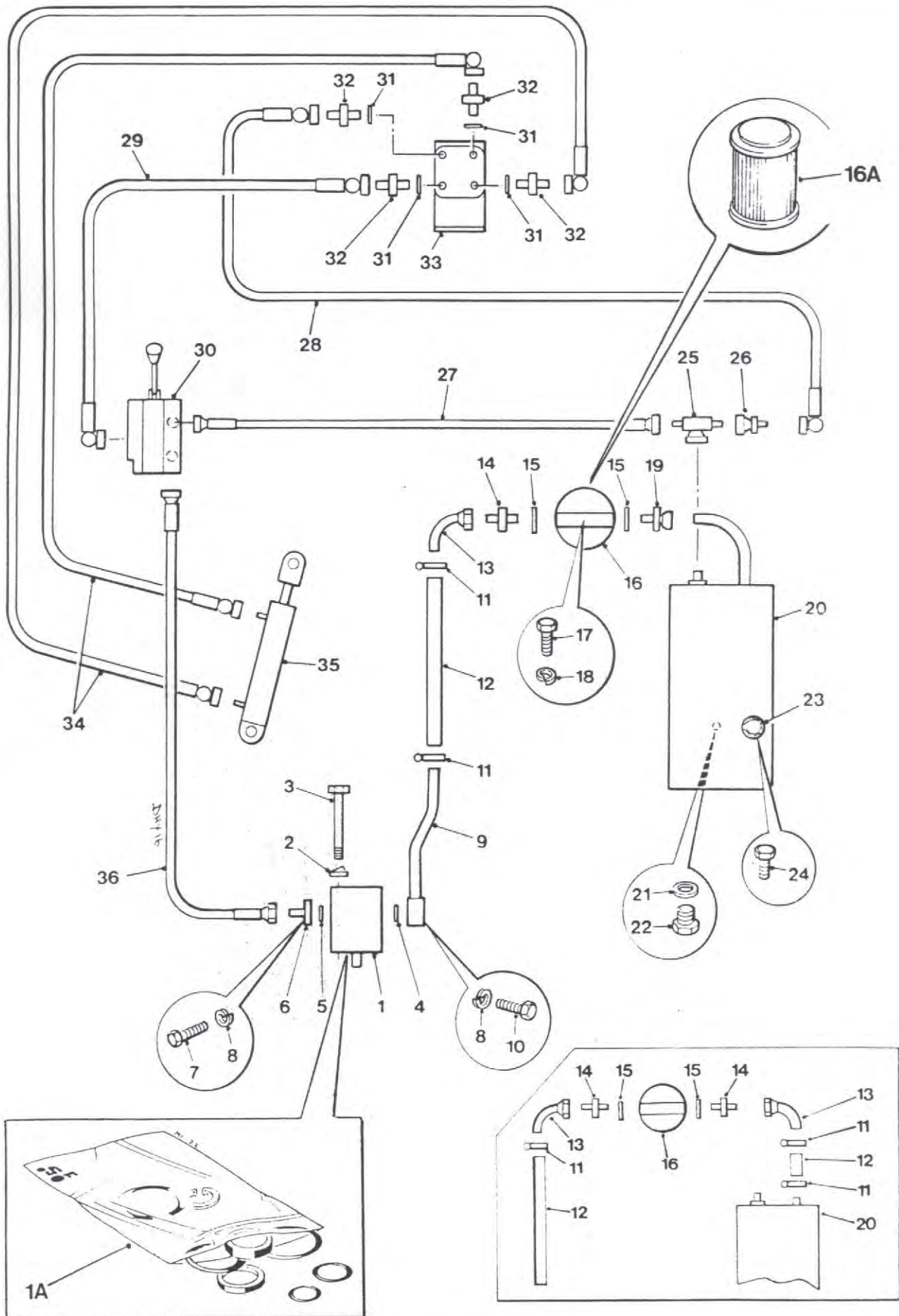

MAIN HYDRAULIC CIRCUIT

7 - A - 1

Item	Part no	Serial no	Description	Qty
1	V2000239	AA01000/ AG01055	PUMP	1
1	V2000416	AG01056/ —	PUMP, OBSOLETE: use V602244	1
1A	V600118	AG01056/ —	KIT, seals	1
1	V602244	— /	PUMP	1
1A	V602245	— /	KIT, seals	1
2	17S05		WASHER, spring	2
3	8S04R	AA01000/ AG01055	BOLT	2
3	8S04S	AG01056/	BOLT	2
4	49S11		'O' RING	1
5	49S01		'O' RING	1
6	V2000287		ADAPTOR	1
7	11S02A		SCREW, set	4
8	17S03		WASHER, spring	8
9	V2000299		PIPE, suction	1
10	8S02D		BOLT	4
11	V2003232		CLIP, hose	4
12	37S03		HOSE (order by metre)	AR
13	129S06F		ELBOW	2
14	V2003174		ADAPTOR	2
15	100S09		SEAL, bonded	2
16	V2000238		FILTER, assembly	1
16A	V600070		ELEMENT, filter	1
17	11S03E		SCREW, set	2
18	17S04		WASHER, spring	2
19	167S16P	AA01000/ AE01026	COUPLING, stud	1
20	V2000223	AA01000/ AE01026	TANK, hydraulic/wing, R.H.	1
20	V2000420	AE01027/	TANK, hydraulic/wing, R.H.	1
21	100S02		SEAL, bonded	1
22	V2003210		PLUG	1
23	V2003269		FILLER/DIPSTICK	1
24	11S01AA		SCREW, set	6
25	154S10		ADAPTOR, tee	1
26	112S02		ADAPTOR	1
27	31S03QQ		HOSE, control valve/tank	1
28	36S02E		HOSE, tank/steer unit	1
29	36S02E		HOSE, control valve/steer unit	1
30	-		CONTROL VALVE (see page 7 - C - 1)	1
31	49S02		'O' RING	4
32	126S04		ADAPTOR	4
33	460293		STEER UNIT	1
34	36S02TT		HOSE, steer unit/ram, steering	2
35	-		RAM, steering (see page 7 - R - 2)	
36	35S03Y		HOSE, pump/control	1

4C4000 & 4C5000 Dumper

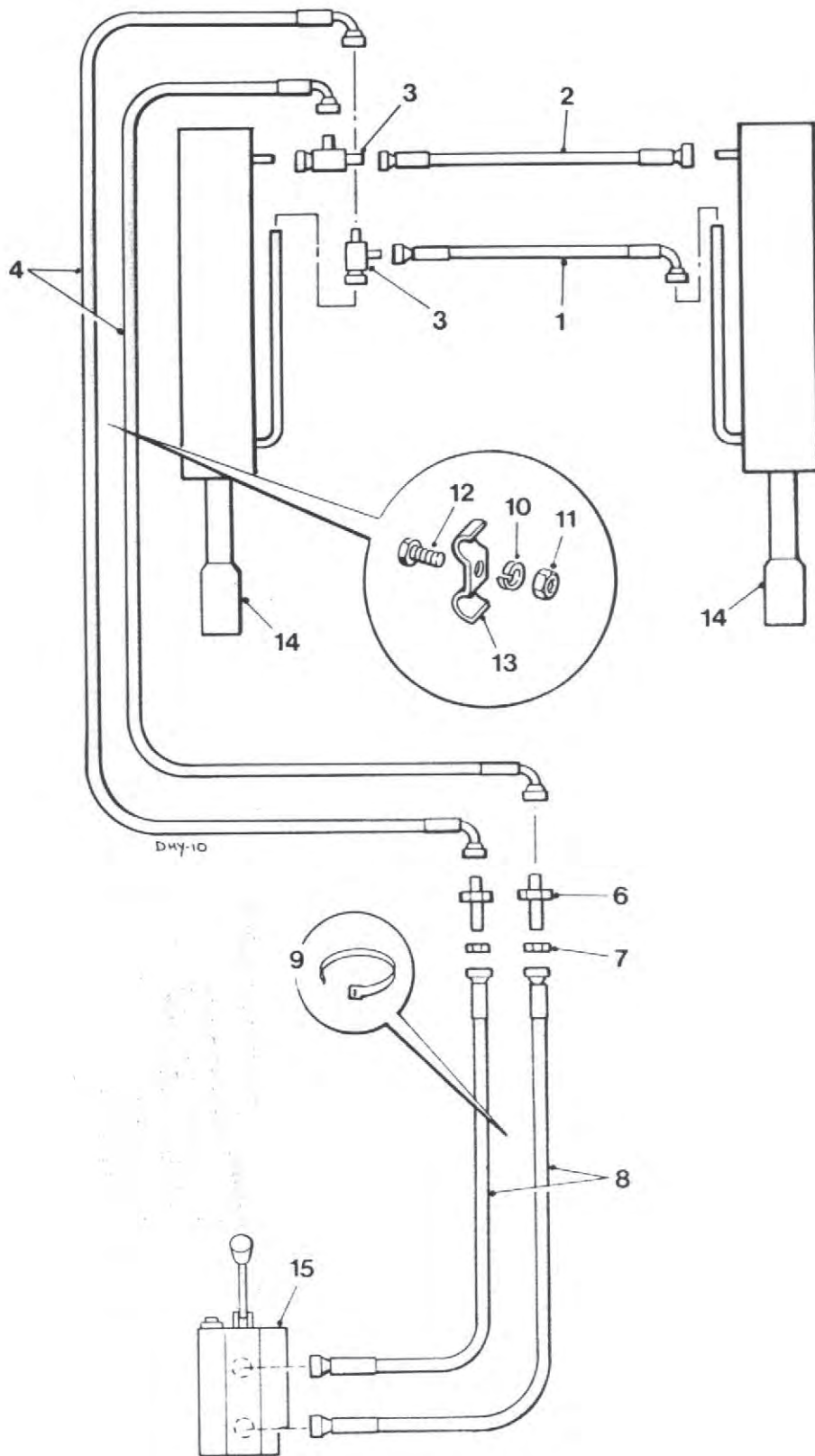

TIPPING HYDRAULIC CIRCUIT

7 - B - 1

Item	Part no	Serial no	Description	Qty
1	36S02UU	AA01000/	HOSE	1
2	35S02R		HOSE	1
3	154S02		ADAPTOR, tee	2
4	35S02AJ		HOSE	2
6	93S01		ADAPTOR, bulkhead	2
7	72S01		NUT, locking	2
8	35S02AE		HOSE	2
9	V2003111		STRAP, nylon	2
10	17S03		WASHER, spring	2
11	7S02		NUT	2
12	11S02C		SCREW, set	2
13	V2003180		CLIP, hose	2
14	-		RAM, tipping (see page 7 - R - 1)	2
15	-		CONTROL VALVE (see page 7 - C - 1)	1

4C4000 & 4C5000 Dumper

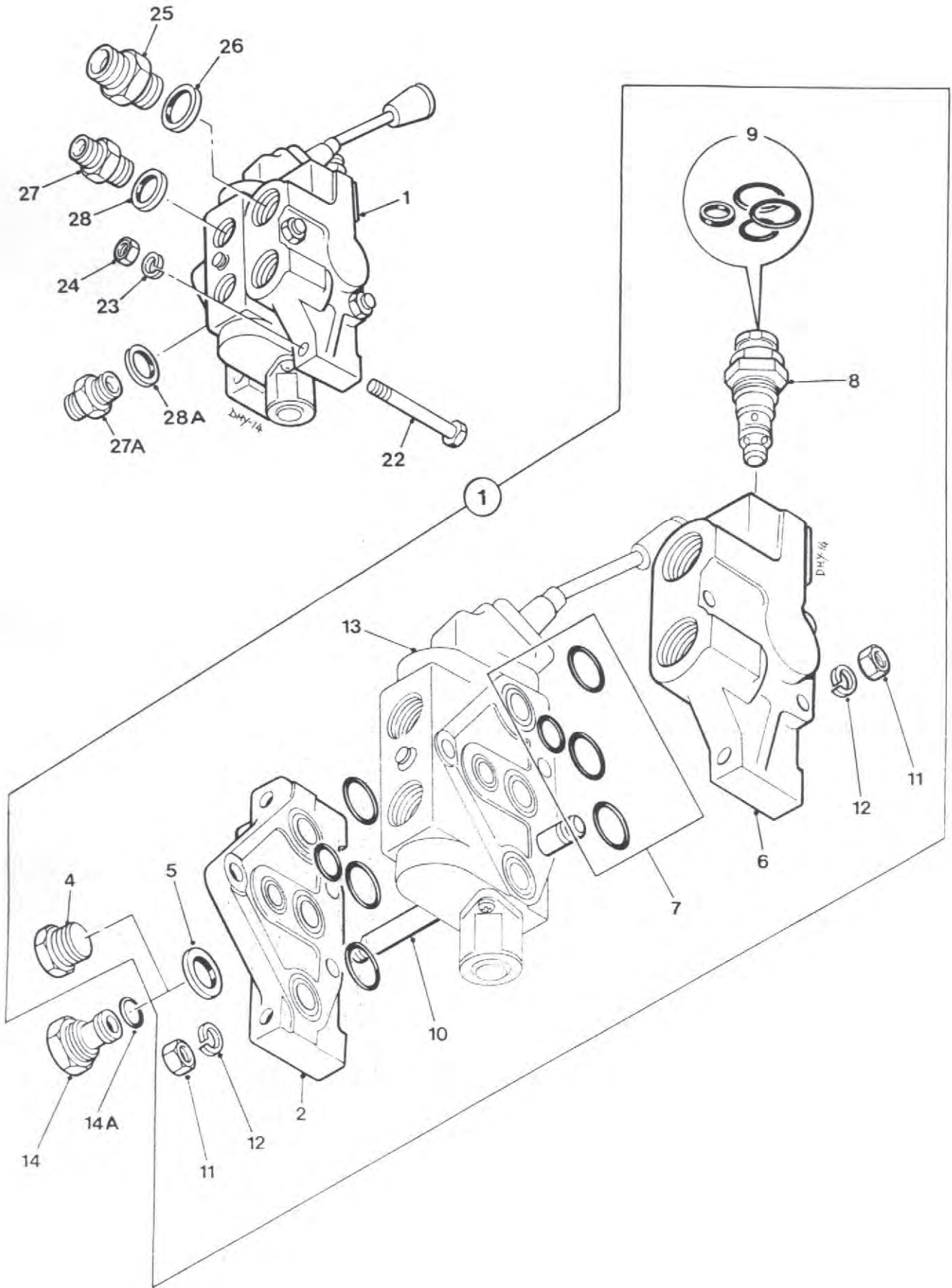

CONTROL VALVE, HYDRAULIC

7 - C - 1

Item	Part no	Serial no	Description	Qty
1	V2000003	AA01000/	CONTROL VALVE, assembly	1
2	V600017		COVER, inlet	1
4	-		"NOT USED"	1
5	100S06		SEAL, bonded	1
6	V2003124		COVER, end	1
7	V600178		KIT, seals	1
8	V600022		VALVE, relief	1
9	V600023		KIT, seals	1
10	V600024		STUD	3
11	9S03		NUT	3
12	41S05		WASHER, spring	3
13	-		SECTION, control valve (see page 7 - C - 2)	1
14	451431029		ADAPTOR, carryover	1
14A	451431005		SEAL, 'O' ring	1
22	8S04J		BOLT	3
23	17S05		WASHER, spring	3
24	7S04		NUT	3
25	119S13		ADAPTOR, to check valve (illustrated)	1
25	119S10		ADAPTOR, to supply hose (not illustrated)	1
26	100S06		SEAL, bonded	2
27	119S08		ADAPTOR	2
27A	119S08		ADAPTOR	1
28	100S04		SEAL, bonded	2
28A	100S04		SEAL, bonded	1

4C4000 & 4C5000 Dumper

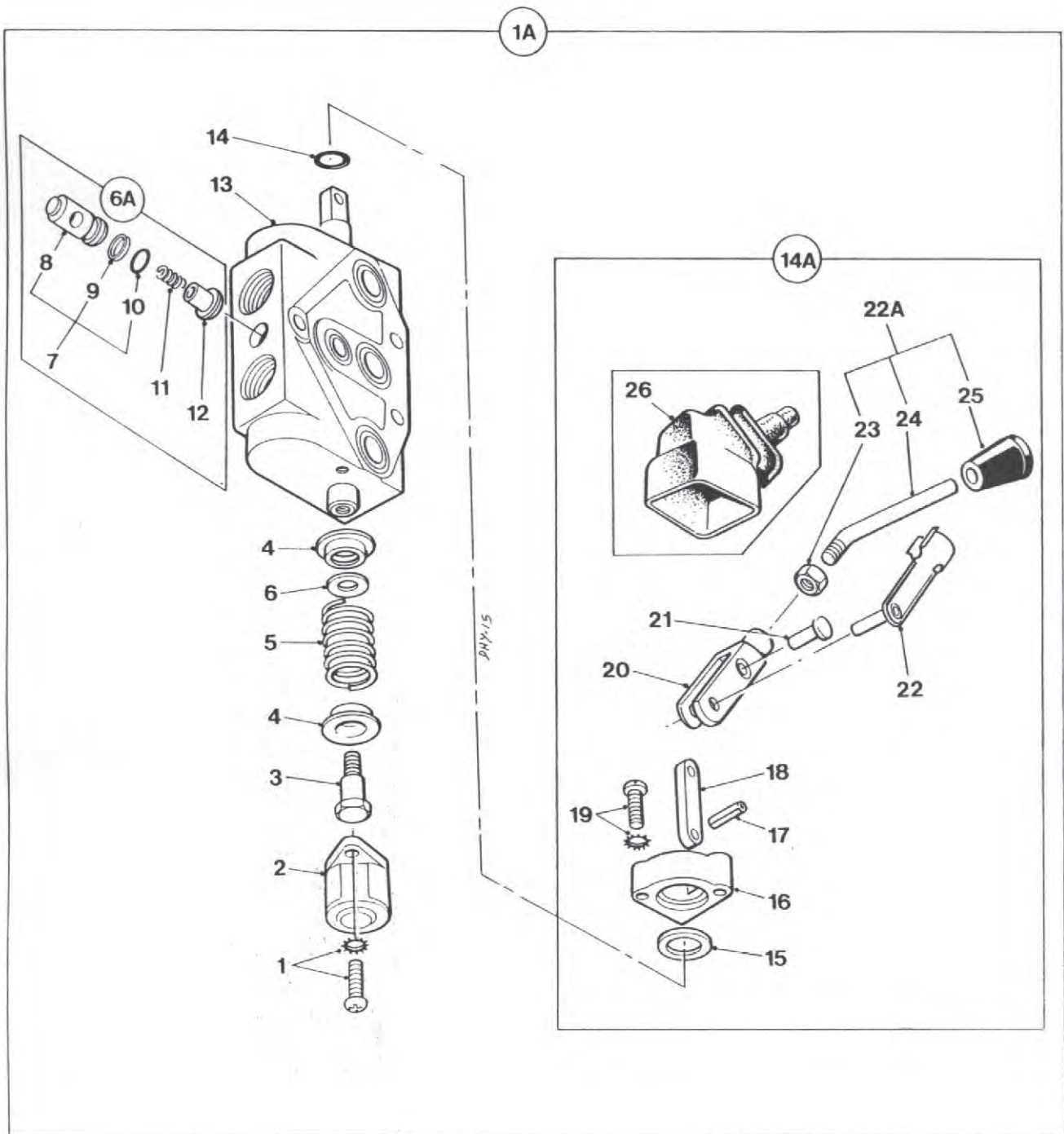

CONTROL VALVE SECTION

7 - C - 2

Item	Part no	Serial no	Description	Qty
1A	V600025	AA01000/	SECTION, control valve, c/w handle, assembly	1
1	V600026		SCREW, c/w washer	2
2	V2003116		CAP, end	1
3	V2003115		SCREW, shoulder	1
4	V2003117		SEAT, spring	2
5	V2003114		SPRING	1
6	V600179		SPACER	1
6A	V600180		CHECK VALVE, assembly	1
7	V600181		KIT, REPAIR, check valve	1
8	V2003118		GUIDE, check valve	1
9	V600182		RING, back up	1
10	V600183		'O' RING	1
11	V2003119		SPRING	1
12	V2003120		POPPET	1
13	V600055		BODY, c/w spool	1
14	V2003113		'O' RING	2
14A	V600057		LEVER, control valve, assembly	1
15	V2003122		SEAL, wiper	1
16	V600059		BRACKET, handle	1
17	V600060		PIN, roll	1
18	V600061		LINK	1
19	V600062		SCREW, c/w washer	2
20	V600063		CLEVIS	1
21	V600064		PIN	1
22	V600065		PIN, clip	1
22A	V600109		LEVER, assembly	1
23	V600066		NUT	1
24	V600067		HANDLE	1
25	V600068		KNOB	1
26	V600069		GAITER	1

4C4000 & 4C5000 Dumper

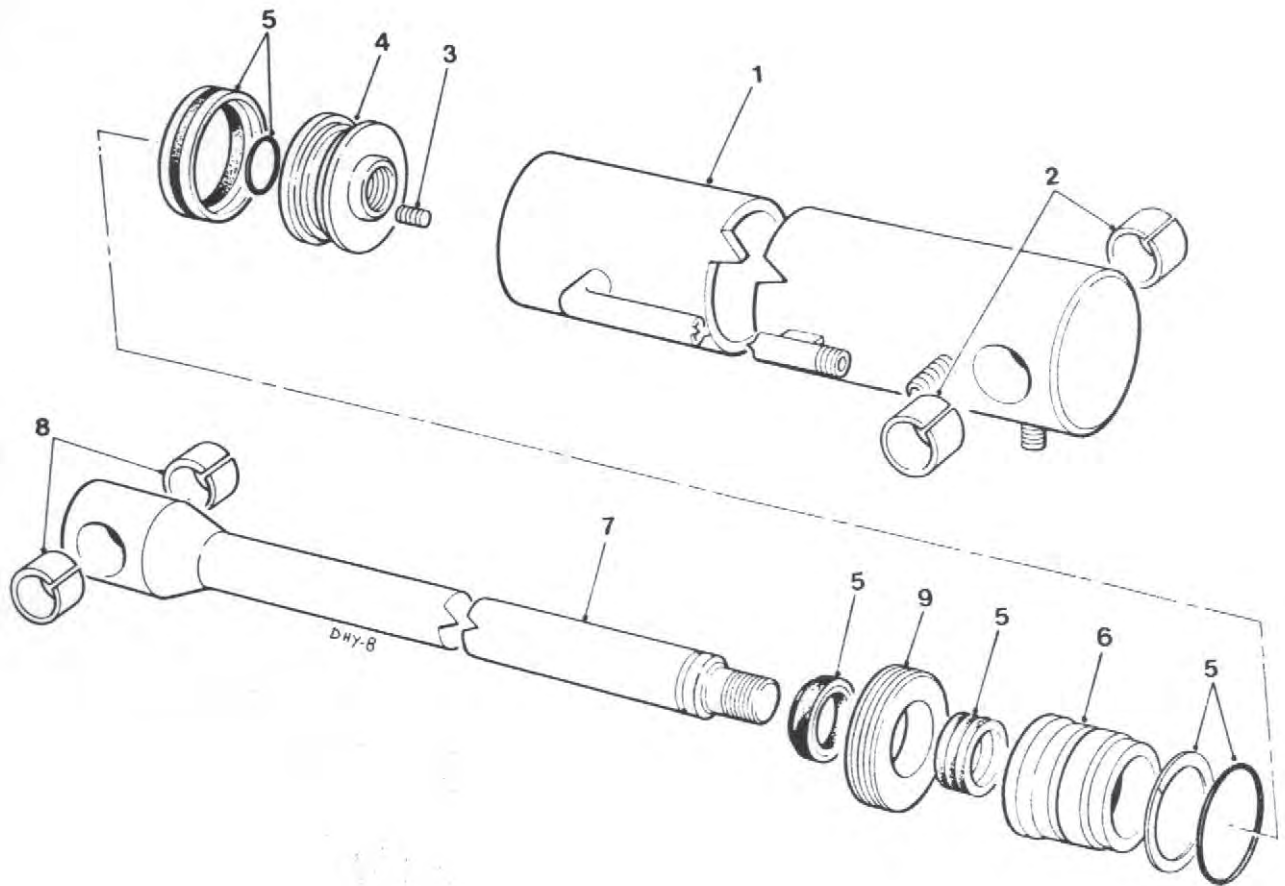

RAM, HYDRAULIC, TIPPING

7 - R - 1

Item	Part no	Serial no	Description	Qty
-	V2000010	AA01000/	RAM, tipping, assembly	2
1	V2000329		CYLINDER,	1
2	V2000331		BUSH	2
3	57S03AB2		SCREW	1
4	V2000209		PISTON	1
5	V2000328		KIT, seals	AR
6	V2003374		RETAINER	1
7	V2000330		ROD, ram	1
8	V2000331		BUSH	2
9	V2003184		END CAP	1

4C4000 & 4C5000 Dumper, to machine serial no BF01243

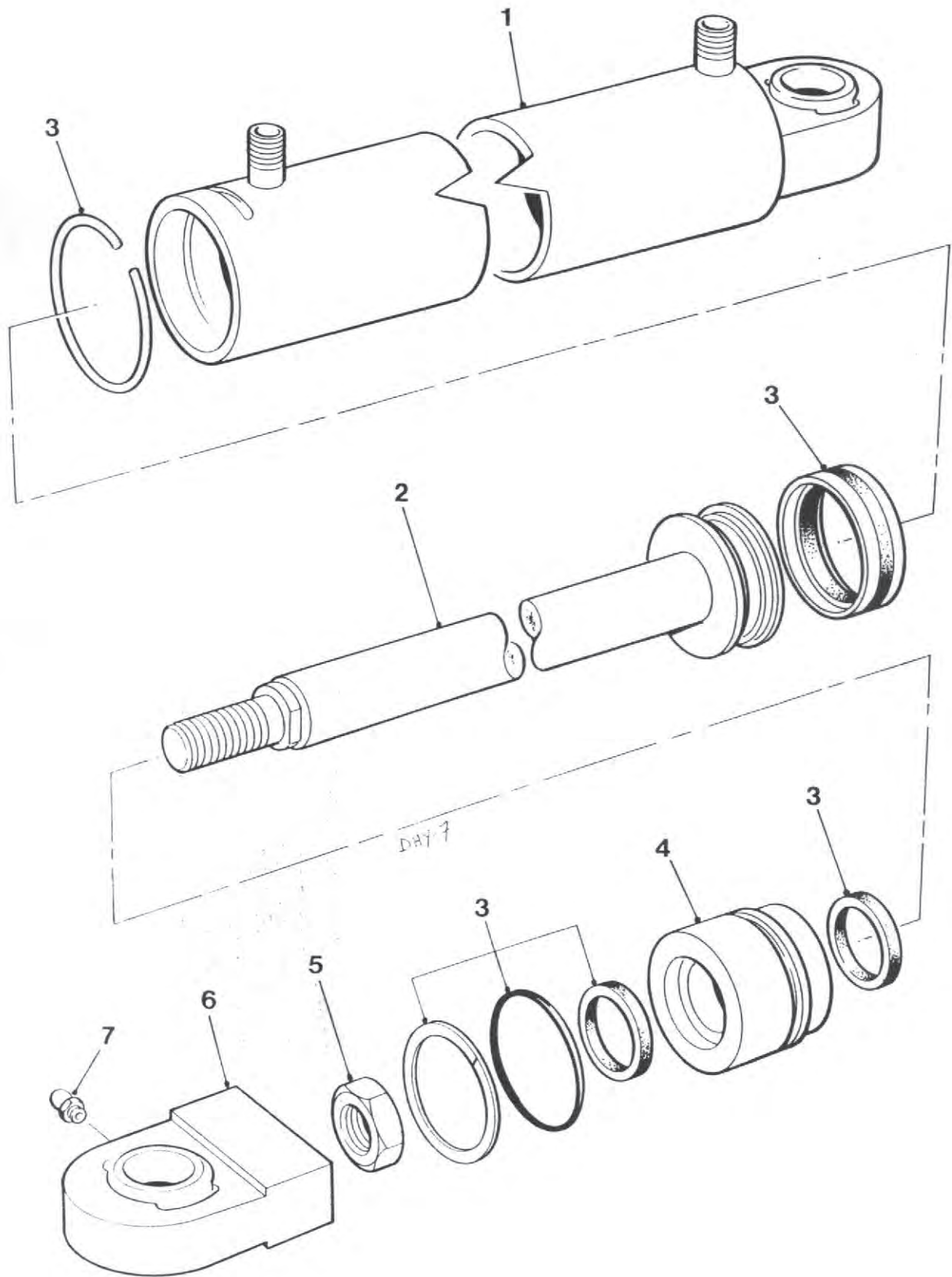

RAM, STEERING

7 - R - 2

Item	Part no	Serial no	Description	Qty
-	V2000011	AA01000/ BF01243	RAM, steering, assembly (OBSOLETE: use V2000901) (see page 7 - R - 3)	1
1	V2000414		CYLINDER, ram	1
2	V2000415		ROD, piston	1
3	V2000413		KIT, seals	AR
4	V2000265		HOUSING, seal	1
5	95S09		NUT	1
6	20100A02		EYE, ram end	1
7	131S01		NIPPLE, grease	2

4C4000 & 4C5000 Dumper, from machine serial no BF01244

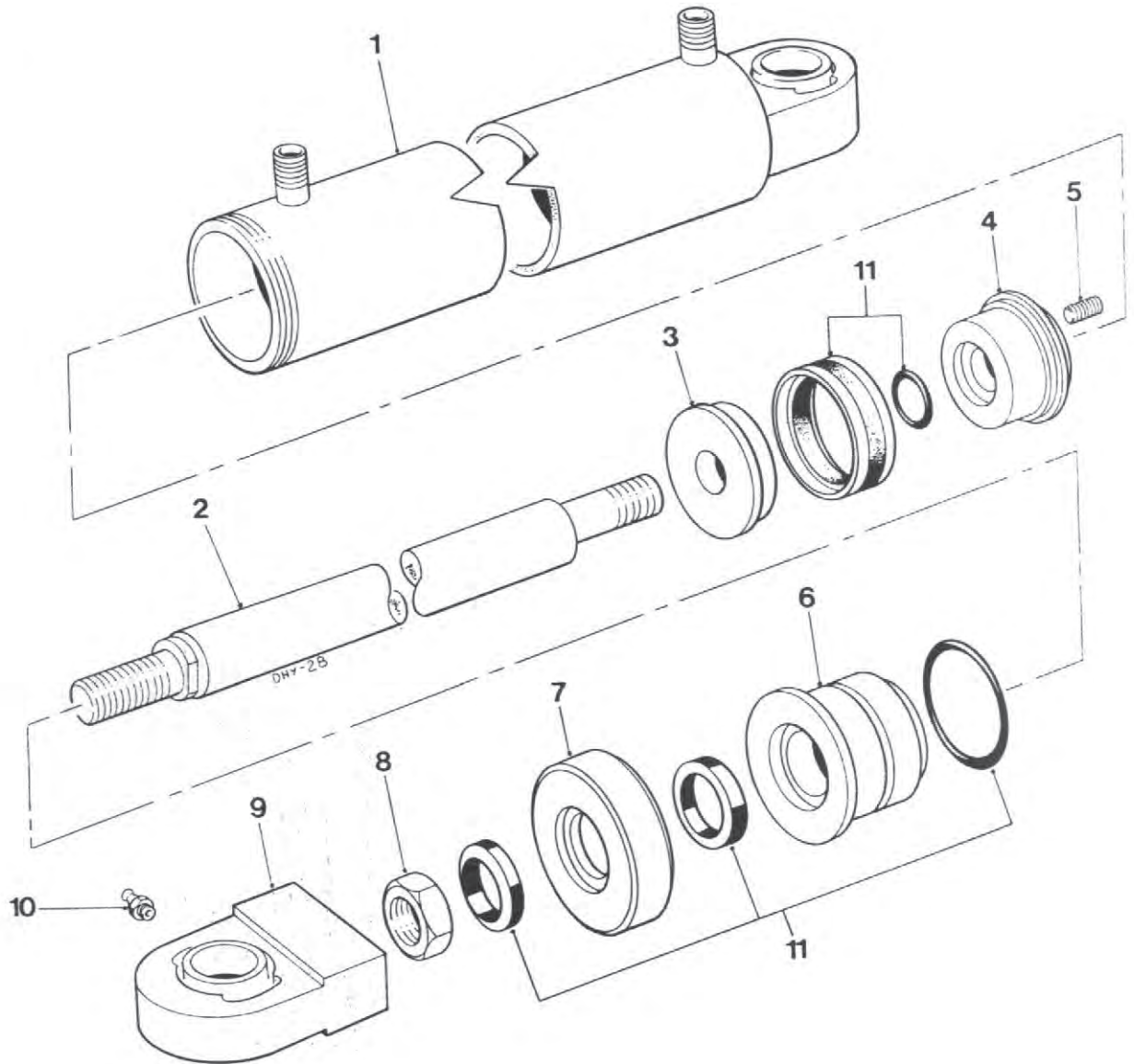

RAM, STEERING

7 - R - 3

Item	Part no	Serial no	Description	Qty
-	V2000901	BF01244/	RAM, steering, assembly	1
1	V2003015		CYLINDER, ram	1
2	30121A0302		ROD, ram (OBSOLETE: use V2002766)	1
2	V2002766		ROD, ram	1
3	30121A0109		PLATE, piston	1
4	30121A0112		PISTON	1
5	57S04D1		GRUBSCREW	1
6	30121A0303		HOUSING, seal	1
7	30121A0105		END CAP, cylinder	1
8	95S09		NUT	1
9	20100A02		EYE, ram end	1
10	131S01		NIPPLE, grease	2
11	V600119		KIT, seals	1

FRAME & PANELS

- 8 - A - 1 FRAME, FRONT
- 8 - A - 2 FRAME, REAR
- 8 - A - 3 LINK, front/rear frame

- 8 - B - 1 PANELS & GUARDS
- 8 - B - 2 CASING, STEERING COLUMN

- 8 - C - 1 SEAT

- 8 - D - 1 CAB, frame & fittings
- 8 - D - 2 MOUNTING BRACKETS, cab
- 8 - D - 3 GLAZING, cab
- 8 - D - 4 INSULATION, cab

- 8 - E - 3 R.O.P.S. FRAME

4C4000 & 4C5000 Dumper

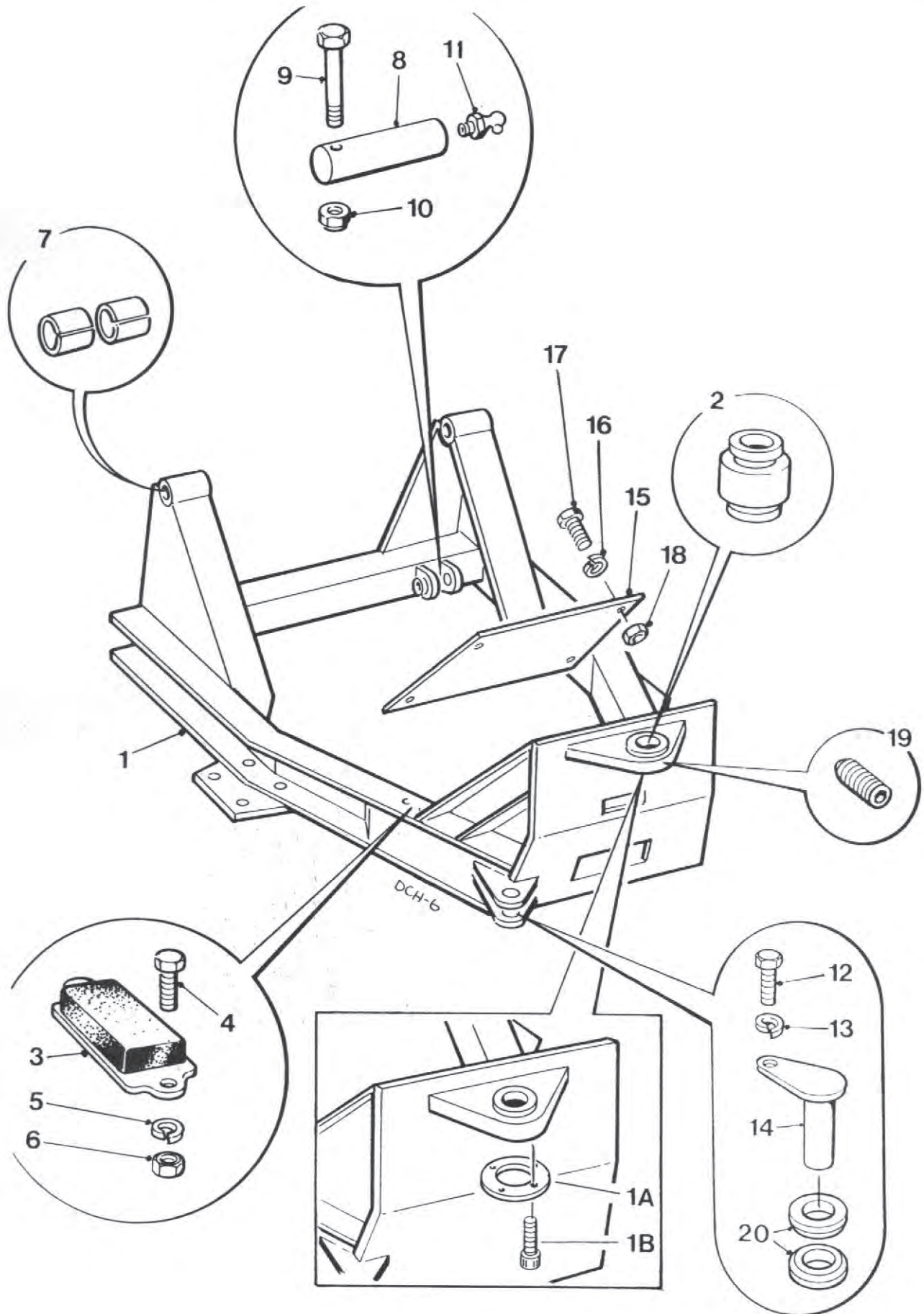

Item	Part no	Serial no	Description	Qty
1	V2000013	AA01000/	FRAME	1
1A	V2000934	FEB 89/	RETAINER	1
1B	68S03C	FEB 89/	SCREW, socket head cap	4
2	V2000250	AA01000/	BUSH	1
3	V2000342	AA01000/	BUMP STOP	2
4	11S05E	AA01000/	SCREW, set	4
5	17S06	AA01000/	WASHER, spring	4
6	-	AA01000/	NUT (welded to chassis)	2
7	V2000276	AA01000/	BUSH	4
8	V2000232	AA01000/	PIN, ram	2
9	8S03L	AA01000/	BOLT	2
10	59S12	AA01000/	NUT, nylon insert	2
11	131S02	AA01000/	NIPPLE, grease	2
12	11S04A	AA01000/	SCREW, set	1
13	17S05	AA01000/	WASHER, spring	1
14	10470A02	AA01000/AM01095	PIN, ram	1
14	V2000557	AM01096	PIN, ram	1
15	V2000410	AA01000/	COVER	1
16	17S03	AA01000/	WASHER, spring	4
17	11S02B	AA01000/	SCREW, set	4
18	7S02	AA01000/	NUT	4
19	188S02D1	AG01041/FEB 89	SCREW, grub	2
20	V2000556	AA01000/	WASHER, conical (welded)	2

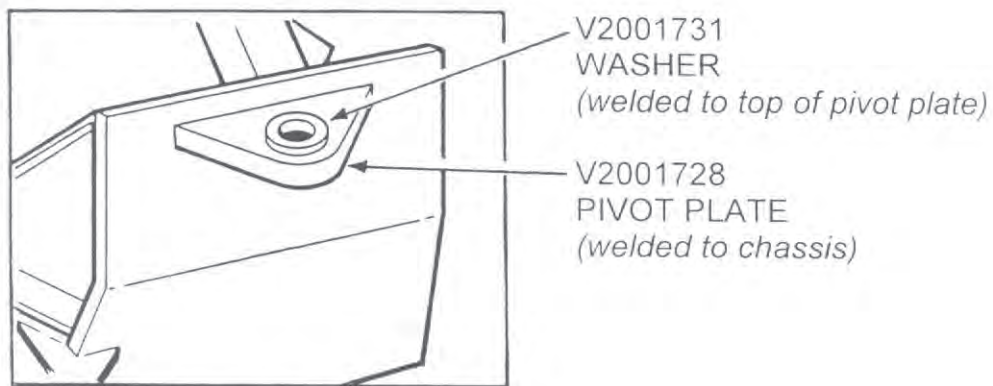

V2001731
 WASHER
(welded to top of pivot plate)

V2001728
 PIVOT PLATE
(welded to chassis)

4C4000 & 4C5000 Dumper

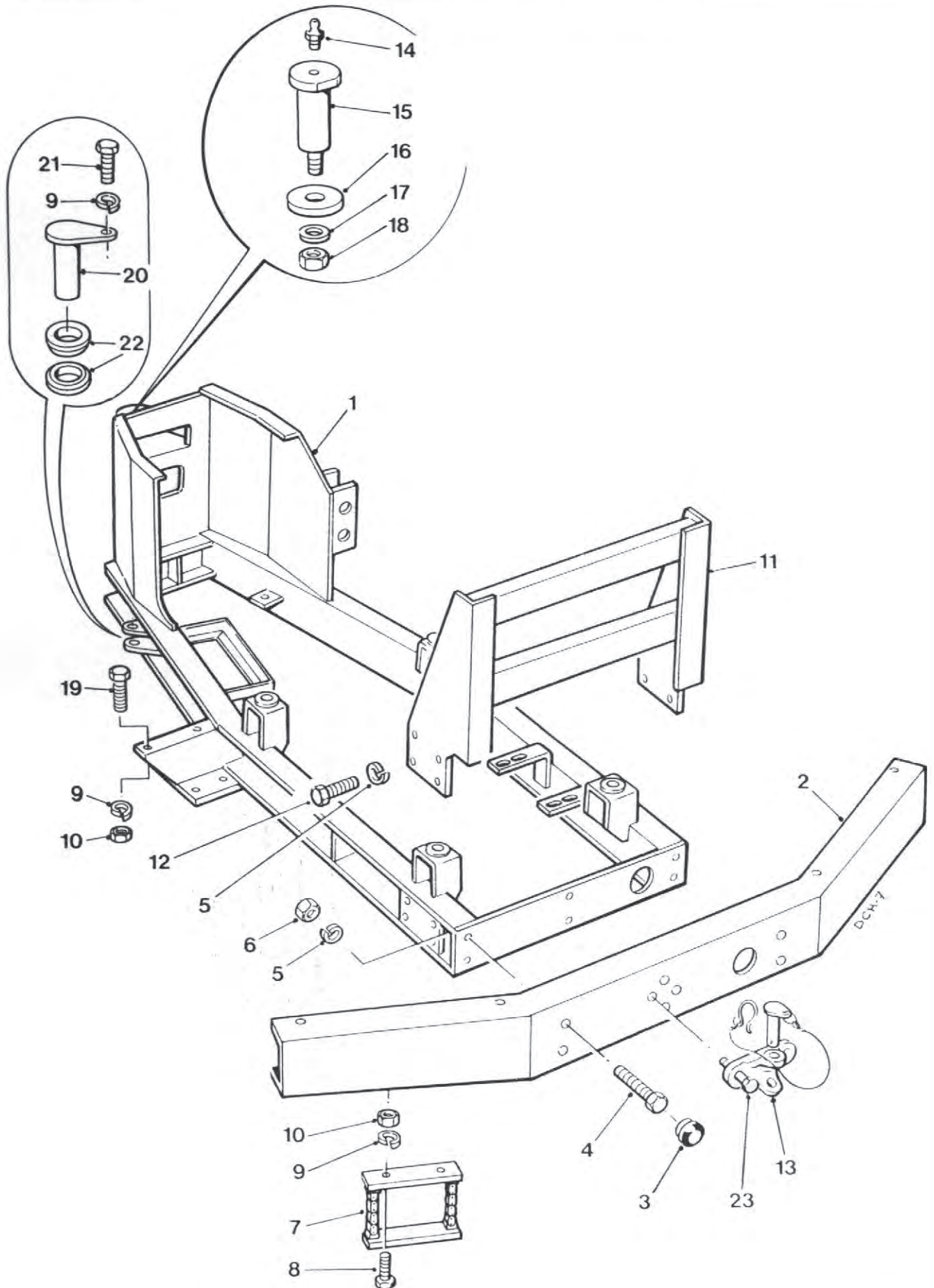

Item	Part no	Serial no	Description	Qty
1	V2000196	AA01000/	FRAME	1
2	V2000315	AA01000/	BUMPER	1
3	V2003186	AA01000/	GROMMET	6
4	11S05E	AA01000/	SCREW, set	6
5	17S06	AA01000/	WASHER, spring	14
6	7S05	AA01000/	NUT	6
7	V2000318	AA01000/AUG 89	STEP (OBSOLETE: use V2001718)	2
7	V2001718	SEPT 89/	STEP	1
8	11S04D	AA01000/	SCREW, set	4
9	17S05	AA01000/	WASHER, spring	9
10	7S04	AA01000/	NUT	8
11	V2000327	AA01000/	GUARD	1
12	11S05D	AA01000/	SCREW, set	8
13	V2000320	AA01000/	TOWHITCH	1
14	131S02	AA01000/	NIPPLE, grease	1
15	V2000337	AA01000/	PIN, pivot	1
16	V2000235	AA01000/	WASHER, special	1
17	267S12	AA01000/	WASHER, flat	1
18	61S08	AA01000/	NUT	1
19	11S04C	AA01000/	SCREW, set	4
20	10470A02	AA01000/AM01095	PIN, ram	1
20	V2000557	AM01096/	PIN, ram	1
21	11S04A	AA01000/	SCREW, set	1
22	V2000556	AA01000/	WASHER, conical (welded)	2
23	28S07K	AA01000/	SCREW	2

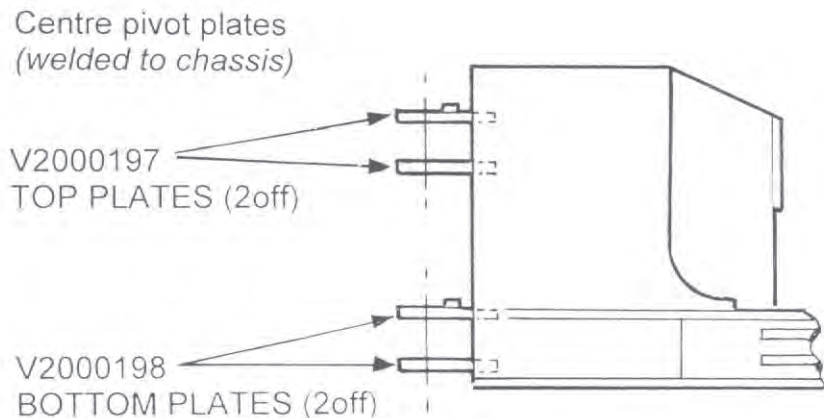

4C4000 & 4C5000 Dumper

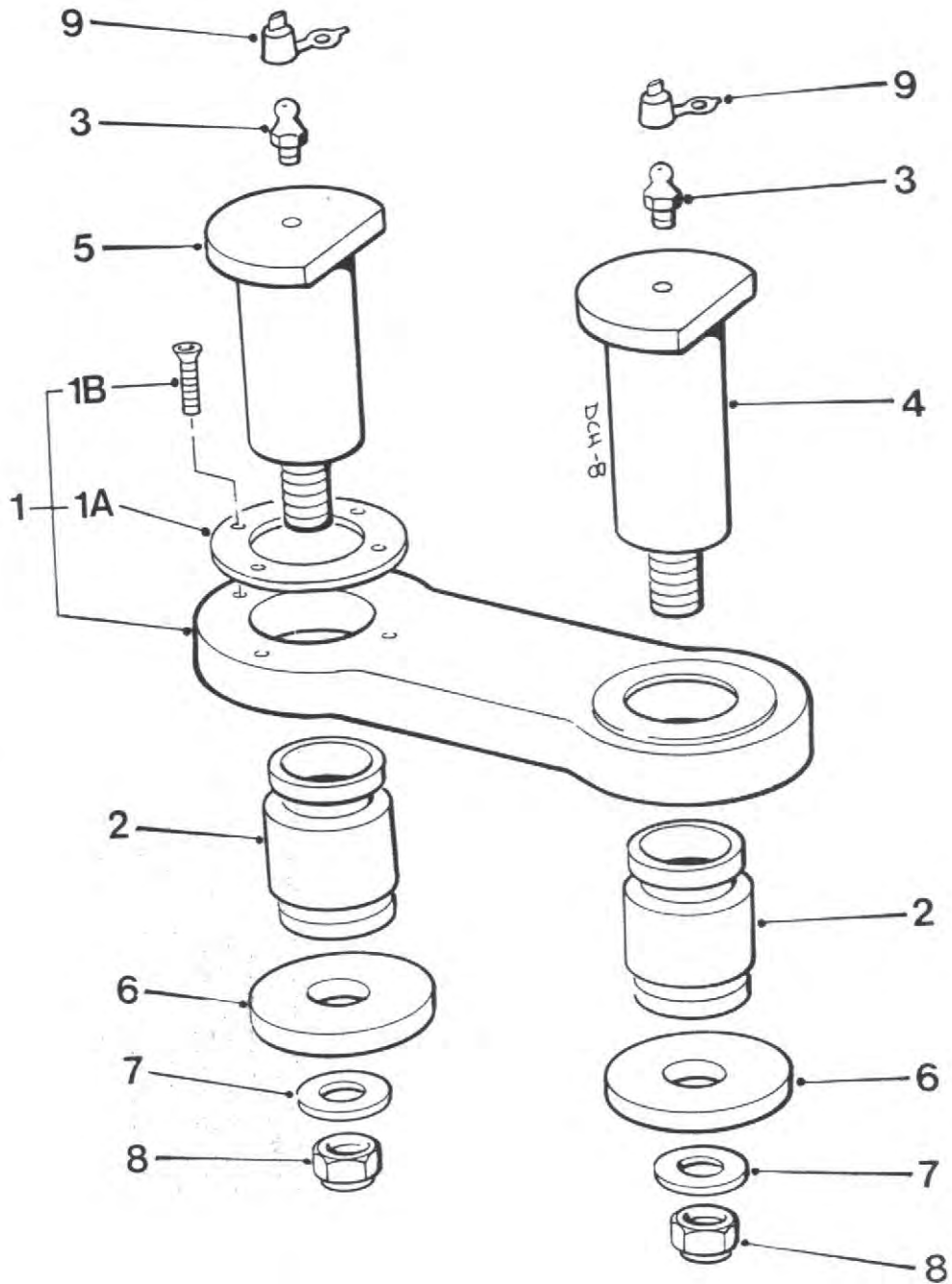

LINK, front/rear frame

8 - A - 3

Item	Part no	Serial no	Description	Qty
1	V2000127	AA01000/	LINK assembly	1
1A	V2001663	NOV 88/	RETAINER	2
1B	52S02C	NOV 88/	SCREW	8
2	V2000250		BEARING	2
3	131S02		NIPPLE, grease	2
4	V2000337		PIN, pivot, rear frame	1
5	V2000234		PIN, pivot, front frame	1
6	V2000235		SPACER	2
7	267S12		WASHER, flat	2
8	61S08		NUT	2
9	176S01		CAP, grease nipple	2

4C4000 & 4C5000 Dumper

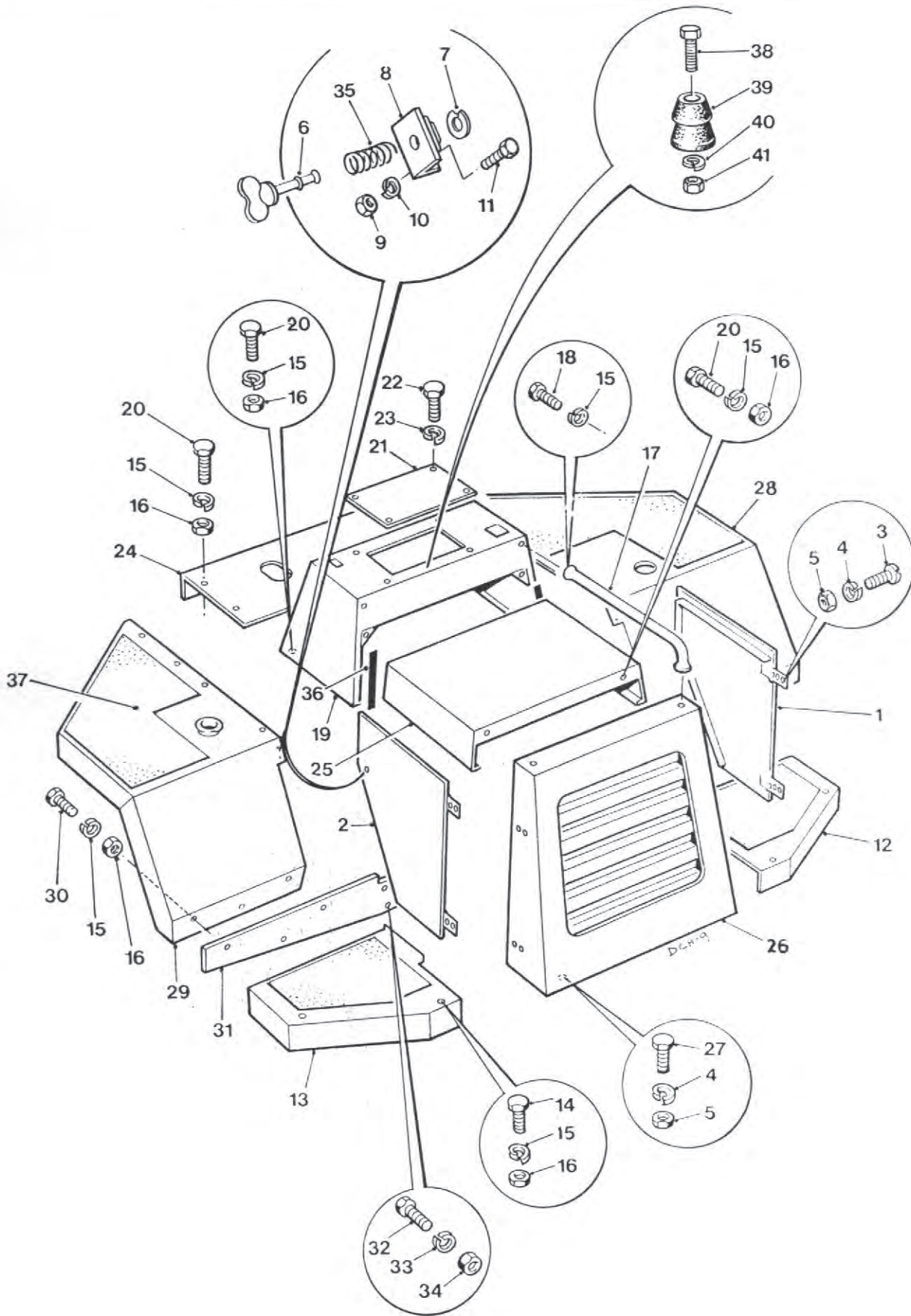

PANELS & GUARDS

8 - B - 1

Item	Part no	Serial no	Description	Qty
1	V2000282	AA01000/	COVER, side, R.H.	1
2	V2000281		COVER, side, L.H.	1
3	16S08C		SCREW	8
4	17S04		WASHER, spring	10
5	7S03		NUT	10
6	V2003222		FASTENER	2
7	V2003223		RETAINER, fastener	2
8	V2000319		BRACKET, side cover catch	2
9	7S01		NUT	4
10	17S02		WASHER, spring	4
11	11S01B		SCREW, set	4
12	V2000317		STEP, R.H.	1
13	V2000316		STEP, L.H.	1
14	11S04C		SCREW, set	4
15	17S05		WASHER, spring	26
16	7S04		NUT	22
17	V2000307		HANDLE	2
18	11S04A		SCREW, set	4
19	V2000227		COVER, front	1
20	11S04B		SCREW, set	12
21	V2000324		PLATE, cover	1
22	11S02A		SCREW, set	4
23	17S03		WASHER, spring	4
24	V2000306		FOOTPLATE	1
25	V2000228		COVER, top	1
26	V2000226		COVER, rear	1
27	11S03C		SCREW, set	2
28	V2000223	AA01000/AE01026	WING, R.H./TANK, hydraulic	1
28	V2000420	AE01027/	WING, R.H./TANK, hydraulic	1
29	V2000224		WING, L.H./TANK, fuel	1
30	11S04E		SCREW, set	6
31	V2000338		STAY	2
32	11S05E		SCREW, set	4
33	17S06		WASHER, spring	4
34	7S05		NUT	4
35	423208280		SPRING	2
36	V2003199		EDGING, trim	AR
37	V2003183		SAFETY WALK	AR
38	11S02C	JAN 89/	SCREW, set	1
39	V2000922	JAN 89/	RETAINER, seat buffer	1
40	17S03	JAN 89/	WASHER, spring	1
41	7S02	JAN 89/	NUT	1

4C4000 & 4C5000 Dumper

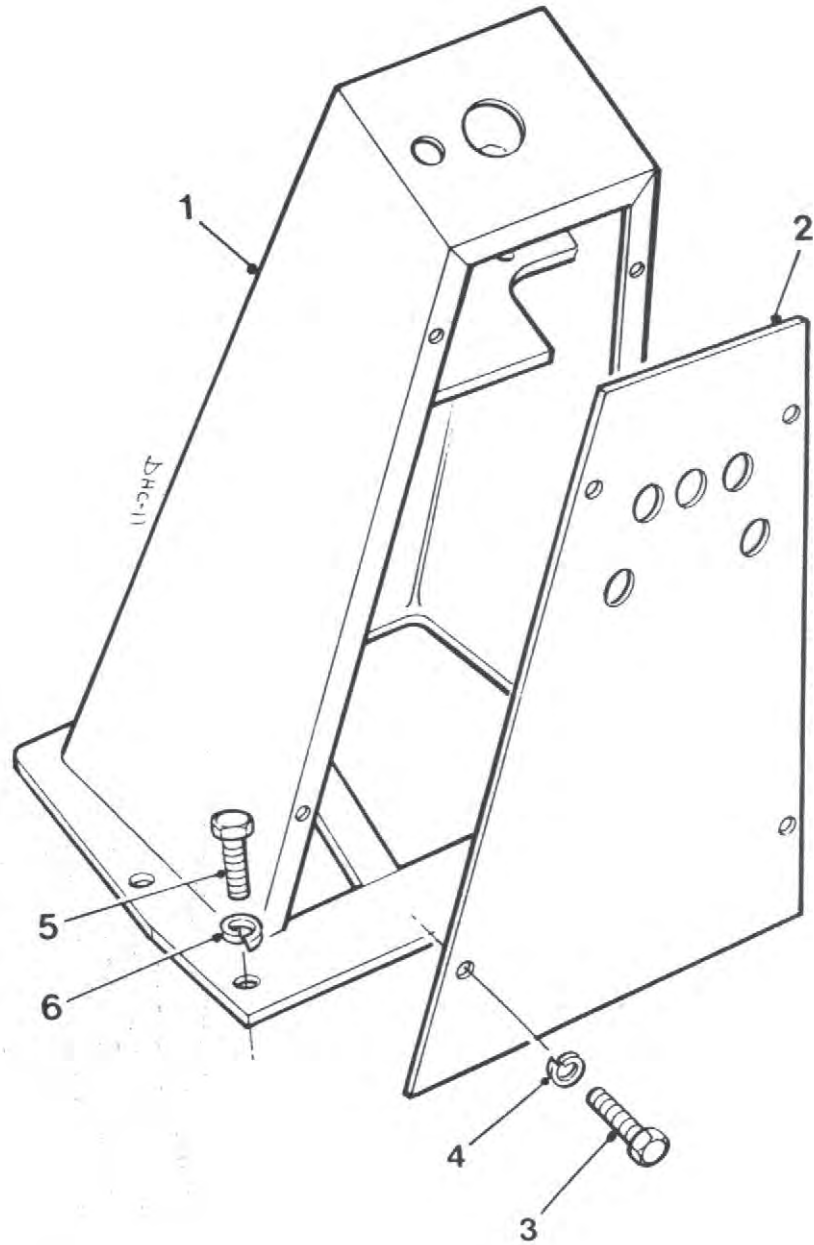

CASING, STEERING COLUMN

8 - B - 2

Item	Part no	Serial no	Description	Qty
1	V2000251	AA01000/	CASING	1
2	V2000296		COVER	1
3	11S02A		SCREW, set	4
4	17S03		WASHER, spring	4
5	11S04D		SCREW, set	4
6	17S05		WASHER, spring	4

4C4000 & 4C5000 Dumper

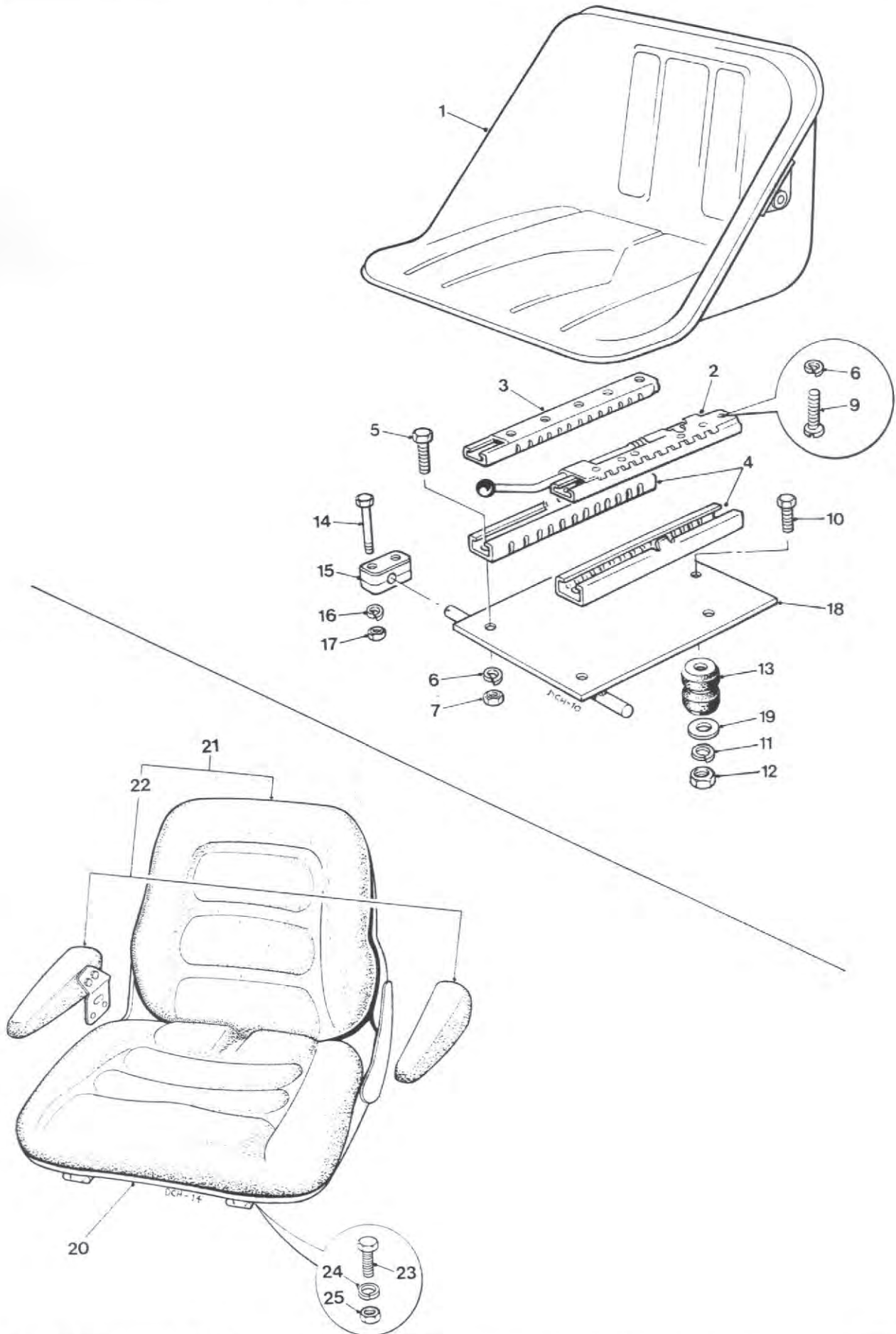

SEAT

8 - C - 1

Item	Part no	Serial no	Description	Qty
1	V2003202	AA01000/	SEAT	1
-	V2003203	AA01000/	SLIDE RAILS, assembly	1
2	V2003204	AA01000/	SLIDE RAIL, locking	1
3	V2003205	AA01000/	SLIDE RAIL, free	1
4	V2003206	AA01000/	SLIDE RAIL, base	2
5	11S03C	AA01000/	SCREW, set	4
6	17S04	AA01000/	WASHER, spring	8
7	7S03	AA01000/	NUT	4
9	16S08C	AA01000/	SCREW, pan head	4
10	11S04C	AA01000/	SCREW, set	1
11	17S05	AA01000/	WASHER, spring	1
12	7S04	AA01000/	NUT	1
13	10519A01	AA01000/	MOUNT, rubber	1
14	8S02F	AA01000/	BOLT	2
15	10364A02	AA01000/	CLAMP	2
16	17S03	AA01000/	WASHER, spring	2
17	7S02	AA01000/	NUT	2
18	V2000295	AA01000/	PLATE, mounting	1
19	267S06	JAN 89/	WASHER, flat	1
Machines with cabs only				
20	V2002138	AK01087/	SEAT	1
21	V600128		SEAT, c/w arm rests	1
22	V2002139		ARM RESTS, c/w fastenings	2
23	11S03A		SCREW, set	4
24	17S04		WASHER, spring	4
25	7S03		NUT	4

4C4000 & 4C5000 Dumper

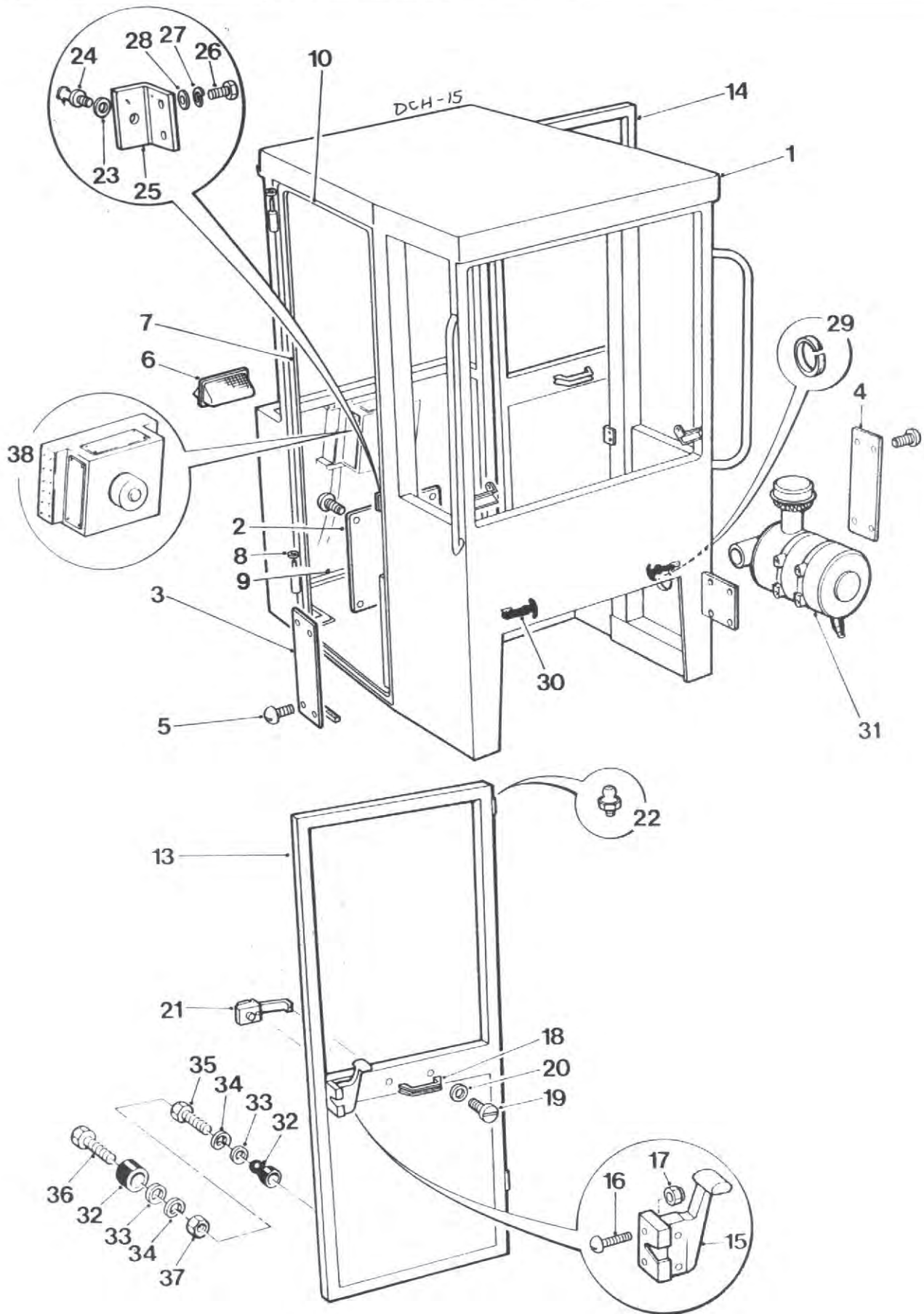

CAB, frame and fittings

8 - D - 1

Item	Part no	Serial no	Description	Qty
-	-	AK010877	GLAZING, cab (see page 8 - D - 3)	
-	V600120		CAB FRAME, assembly	1
1	-		FRAME, cab (order assembly)	1
2	V600121		PLATE, access	1
3	V600122		PLATE, access, L.H.	1
4	V600123		PLATE, access, R.H.	1
5	219S06E		SCREW	12
6			VENT, air	2
7			STRIP, weather (order by metre)	AR
8	V600494		WASHER, flat	4
9	V600124		SEAL (order by metre)	AR
10			STRIP, sealing (order by metre)	AR
-	V600125		DOOR, assembly, L.H.	1
-	V600126		DOOR, assembly, R.H.	1
13	-		FRAME, door, L.H. (order ssembly)	1
14	-		FRAME, door, R.H. (order assembly)	1
15	V2003229		HANDLE, door, inner, L.H. (illustrated)	1
-	V2003228		HANDLE, door, inner, R.H. (not illustrated)	1
16	14S04E		SCREW	4
17	59S14		NUT, nylon insert	4
18	V2003215		DOOR PULL	2
19	-		SCREW, pan head	4
20	12S01		WASHER, flat	4
21	V2003234		HANDLE, exterior	2
-			LOCK	2
-			KEY	2
22			NIPPLE, grease	4
23	V2003230		WASHER, flat	2
24	V600495		PIN, striker	2
25	V600127		BRACKET	2
26	11S03B		SCREW	4
27	17S04		WASHER, spring	4
28	12S03		WASHER, flat	4
29	-		TRIM (order by metre)	AR
30	-		FASTENER	2
31	-		AIR CLEANER (see Engine Section)	
32	V2003200		RETAINER, door	2
33	267S04		WASHER, flat	4
34	17S03		WASHER, spring	4
35	11S02C		SCREW, set	2
36	11S02D		SCREW, set	2
37	7S02		NUT	2
38	-		HEATER (see page 4 - C - 4A)	

MOUNTING BRACKETS, cab

8 - D - 2

Item	Part no	Serial no	Description	Qty
1	V600129	AK01087/	BRACKET, mounting, frame	2
2	V600130		PEDESTAL, bracket	2
3	V600131		BUSH	4
4	69S06WW		BOLT	4
5	10S27		WASHER, flat	8
6	V600132		SPACER	8
7	202S17		NUT, locking	4
8	8S05D		BOLT	4
9	59S04		WASHER, flat	12
10	12S23		NUT, locking	12
11	8S05E		BOLT	8

4C4000 & 4C5000 Dumper

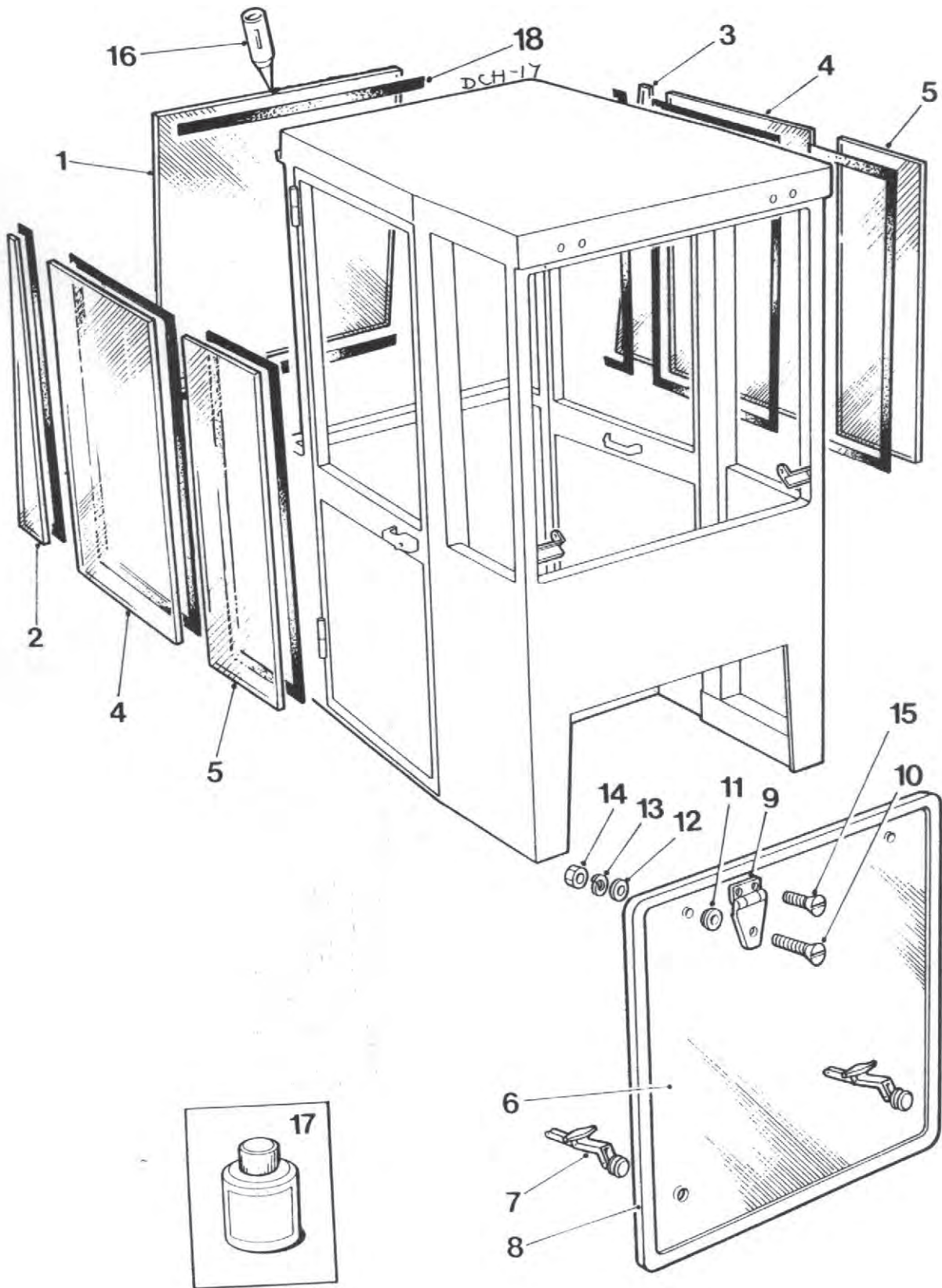

GLAZING, cab

8 - D - 3

Item	Part no	Serial no	Description	Qty
1	V600133	AK010877	GLASS, front screen, plain	1
2	V600134		GLASS, quarterlight, plain, L.H.	1
3	V600135		GLASS, quarterlight, plain, R.H.	1
4	V600136		GLASS, door	2
5	V600137		GLASS, side	2
6	V600138		GLASS, rear	1
7	V600139		CATCH	2
8	V600140		SEAL (order by metre)	AR
9	V600141		HINGE	2
10	11S03C		SCREW, set	2
11			WASHER, rubber	2
12	267S05		WASHER, flat	2
13	17S04		WASHER, spring	2
14	7S03		NUT	2
15	11S03B		SCREW	4
16	V2003235		SEALANT, black	tube 1
17	V2003236		PRIMER	can 1
17	V2003237		CONDITIONER	can 1
18	V2003238		TAPE, damming	AR

4C4000 & 4C5000 Dumper

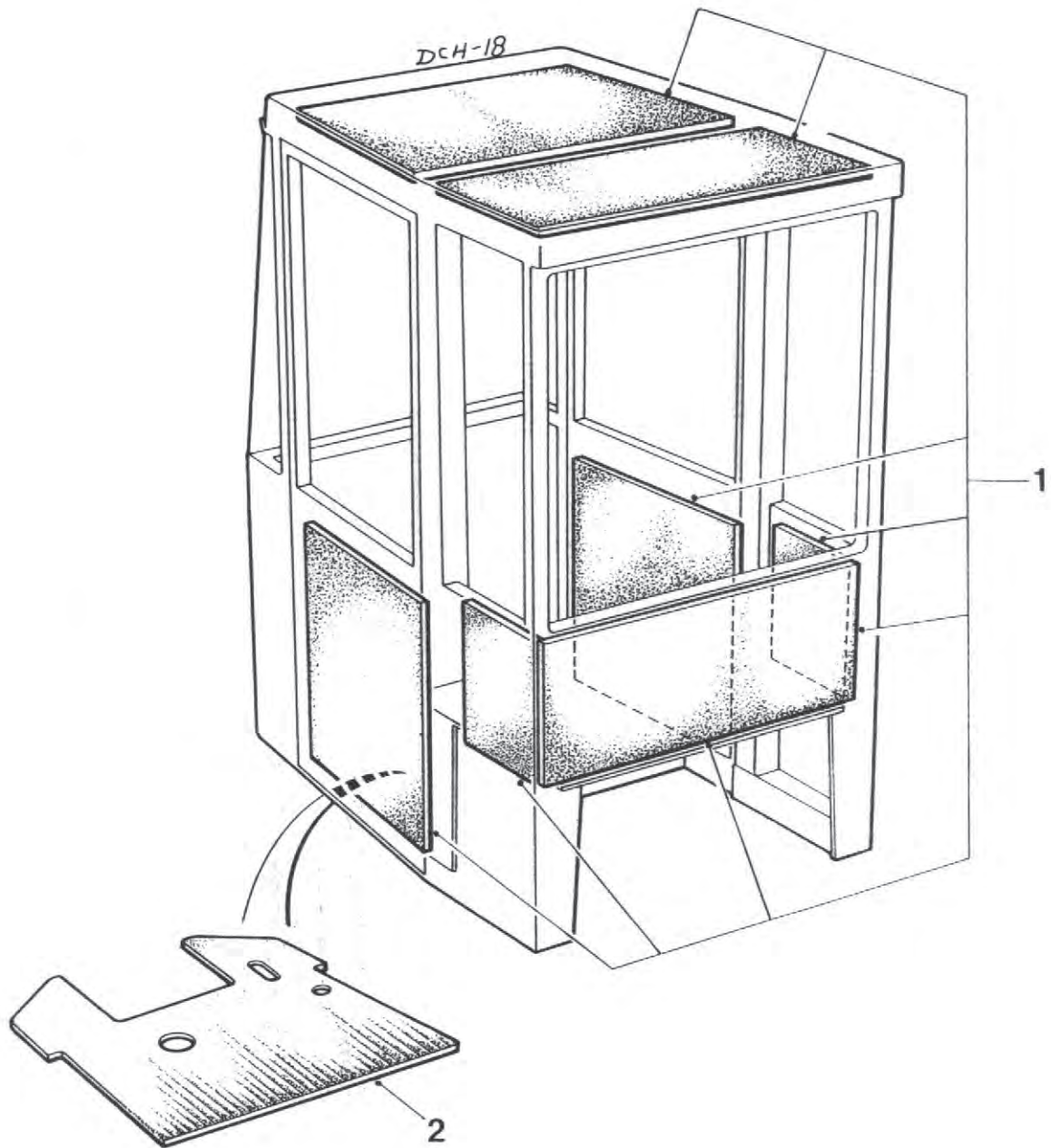

INSULATION, cab**8 - D - 4**

Item	Part no	Serial no	Description	Qty
1	V2002135	AK010877	KIT, insulation	1
2	V2002136		MAT, floor	1

4C4000 & 4C5000 Dumper

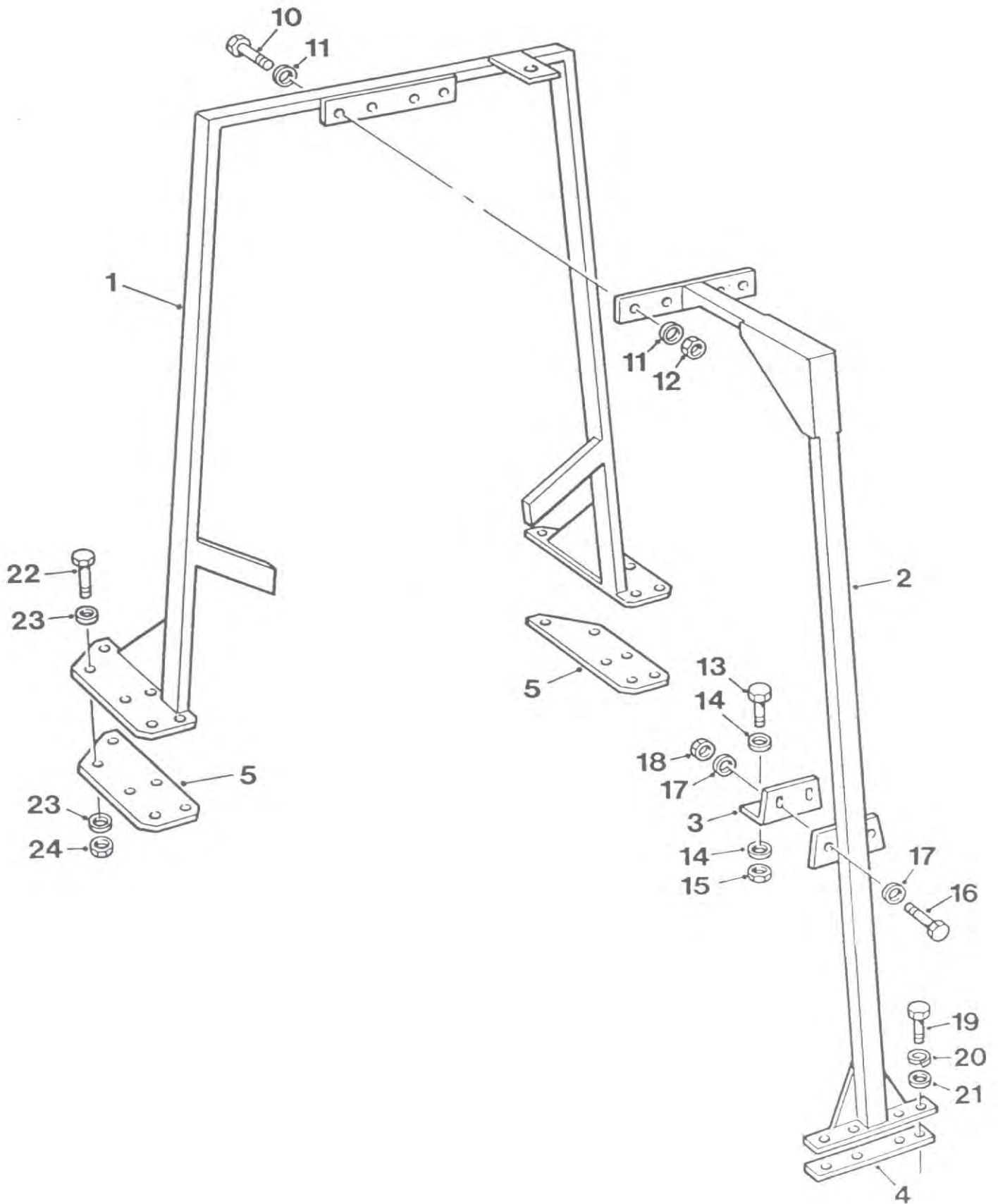

R.O.P.S. FRAME KIT

8 - E - 1

Item	Part no	Serial no	Description	Qty
.....	V602774		R.O.P.S. KIT, includes all items listed below plus KAB XH2/P2N seat assembly to ISO 6683, part number V2005013.	
1	V2005067		R.O.P.S. FRAME (c/w item 2)	1
2		SUPPORT, rear, (Part of item 1)	1
3	V2005203		BRACKET, retaining	1
4	V2005204		PLATE, threaded	1
5	V2005072		PLATE, clamping	2
10	8S06H		BOLT	4
11	267S09		WASHER, flat	8
12	59S11		NUT, nyloc	4
13	8S05D		BOLT	2
14	267S07		WASHER, flat	4
15	59S04		NUT, nyloc	2
16	8S05D		BOLT	2
17	267S07		WASHER, flat	4
18	59S04		NUT, nyloc	2
19	8S06D		BOLT	4
20	17S08		WASHER, spring	4
21	267S09		WASHER, flat	4
22	8S06H		BOLT	12
23	267S09		WASHER, flat	24
24	59S11		NUT, nyloc	12
.....	V2005030		PLATE, R.O.P.S. identification	1
.....	101S05D		RIVET, for above identification plate	4
.....	V2004754		DECAL, damage to frame	1

MISCELLANEOUS

9 - A - 2 DECALS

9 - A - 3 DECALS



4C4000 & 4C5000 Dumper

1 HYDRAULIC OIL

2 DIESEL FUEL



4 **WINGET**

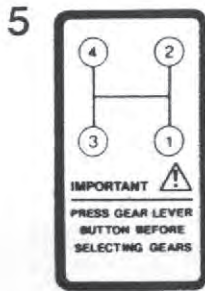

6 **4C4000**

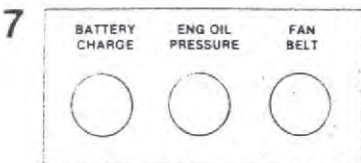

8 **50 p.s.i.**

9 **IMPORTANT**
CHANGE HYDRAULIC OIL
FILTER ELEMENT AFTER FIRST
100 HOURS AND THEREAFTER
EVERY 300 HOURS



12 TAKE EXTRA CARE WHEN TIPPING
NON FREE RUNNING LOADS

13 **maximum payload 4000 kgs**

14 **WINGET DUMPER SAFETY**

- BEFORE OPERATING THIS MACHINE THE DRIVER SHOULD BE FAMILIAR WITH THE OPERATING INSTRUCTIONS ISSUED BY THE MANUFACTURER.
- THE MANUFACTURER'S RATED PAYLOAD MUST NEVER BE EXCEEDED. THE WEIGHT OF ALL LOADS ABOVE SEEP WATER LEVEL MUST BE CHECKED.
- PASSENGERS MUST NOT BE CARRIED AT ANY TIME.
- USE EXTREME CARE WHEN DESCENDING STEEP GRADIENTS AND KEEP SPEED TO A MINIMUM.
- DO NOT APPLY BRAKES VIOLENTLY WHEN TRAVELLING DOWN STEEP GRADIENTS.
- DO NOT TOW DOWN GRADIENTS OTHERWISE JACK KNOCKING MAY OCCUR.
- DUMPER ARE NOT DESIGNED AS TOWING VEHICLES BUT LOADS INCLUDING WEIGHT OF TRAILER NOT EXCEEDING THE RATED PAYLOAD OF THE DUMPER MAY BE TOWED ON LEVEL GROUND IN FIRST GEAR PROVIDED THE DUMPER IS LOADED WITH HALF THE RATED PAYLOAD TO ENSURE TIRE ADHESION WHEN BRAKING.
- NEVER DRIVE THE MACHINE TOO CLOSE TO THE EDGE OF ANY EXCAVATION PARTICULARLY AT THE CRUISING SPEEDS OR SET.
- NEVER MAKE ANY ADJUSTMENTS TO THE MACHINE WHILE IT IS IN MOTION.
- NEVER FILL THE FUEL TANK WITH THE ENGINE RUNNING EXERCISE CAUTION WHEN THE ENGINE IS HOT.
- ALWAYS KEEP THE FLOOR PLATES CLEAN.
- NEVER DISMOUNT WHILE MACHINE IS IN MOTION.
- ALWAYS APPLY HANDBRAKE BEFORE LEAVING THE DRIVER'S SEAT.

OPERATORS INSTRUCTIONS

- CHECK CONDITION AND PRESSURE OF TIRES DAILY.
- CHANGE HYDRAULIC OIL FILTER ELEMENT AFTER FIRST 100 HOURS AND THEREAFTER EVERY 300 HOURS.
- THE WARRANTY OF THIS VEHICLE OPERATES ON THE TRANSMISSION AND MUST ONLY BE USED FOR TIPPING OF FREIGHT. STOP DAMAGE MAY BE CAUSED IF USED AS A SERVICE TRUCK.

15 **NEGATIVE EARTH**

16 **WARNING**
DO NOT WORK UNDER
UNPROPPED SKIP

17 **KEEP CLEAR**
OF THIS AREA
WHEN ENGINE
IS RUNNING



DECALS & PLATES

9 - A - 2

Item	Part no	Serial no	Description
1	V2003100		"HYDRAULIC OIL"
2	V2003101		"DIESEL FUEL"
3	V2003103		"STRIPE", bodywork, 3 colour (OBSOLETE: use V2003038 2 colour)
3	V2003038		"STRIPE", bodywork, 2 colour
4	V2003039		LOGO
5	V2003157		GEARBOX GATE
6	V2000346		"4C4000"
7	V2000348		WARNING LIGHTS
8	10166A02		"TYRE PRESSURE 50PSI"
9	10215A03		FILTER INSTRUCTION
10	10284A01		"DUMP/RETURN"
11	10317A05		PLATE, serial number (OBSOLETE: use V2003037)
11	V2003037		PLATE, serial number
12	10536A02		"NON FREE RUNNING LOADS"
13	10541A27		"MAXIMUM PAYLOAD 4000KGS"
14	20132A03		DUMPER SAFETY, plate
15	4602331		"NEGATIVE EARTH"
16	DM157		SKIP WARNING
17	DM198		"KEEP CLEAR - STEERING LOCK" WARNING
18	FSE357		"ENGINE STOP"

1 **2B 1000**

2 **2B 1500**

3

RECOMMENDED LUBRICATING OILS					
COMPONENT	GRADE	SAE GRADE	API GRADE	SAE GRADE	API GRADE
Engine	SAE 15W-40	SAE 15W-40	SAE 15W-40	SAE 15W-40	SAE 15W-40
Hydraulic System	SAE 46	SAE 46	SAE 46	SAE 46	SAE 46
Transmission	SAE 80W-90	SAE 80W-90	SAE 80W-90	SAE 80W-90	SAE 80W-90
Final Drive	SAE 90	SAE 90	SAE 90	SAE 90	SAE 90
Wheel Bearings	SAE 30	SAE 30	SAE 30	SAE 30	SAE 30
Grease	SAE 2	SAE 2	SAE 2	SAE 2	SAE 2

4 **4B 2500**

5 **4B 3000**

6 **40 p.s.i.**

7 **WARNING!**
TIGHTEN WHEEL
NUTS DAILY

8 **4B2000**

9 **35 p.s.i.**

10 **maximum payload 2000 kgs**

11 **maximum payload 5000 kgs**

12 **4C5000**

13  **FLASHING BEACON**
ON ← → OFF

14 **HANDBRAKE
WARNING**

DECALS & PLATES

9 - A - 3

Item	Part no	Serial no	Description
1	V2003152		"2B1000"
2	V2003153		"2B1500"
3	DM196		"LUBRICATION OIL", 4C4000, 4C5000, 4B2500 & 4B3000
3	DM197		"LUBRICATION OIL", 4B2000, 2B1000, 2B1500
4	V2003155		"4B2500"
5	V2003156		"4B3000"
6	10540A01		"40psi" tyre pressure
7	V2003142		"WARNING - WHEEL NUTS"
8	V2003154		"4B2000"
9	10540A02		"35psi" tyre pressure
10	10540A13		"MAX PAYLOAD 2000KGS"
11	10541A38		"MAXIMUM PAYLOAD 5000KGS"
12	V2001650		"4C5000"
13	V2003143		"FLASHING BEACON"
14	V2002552		"HANDBRAKE WARNING"

CALIFORNIA

Proposition 65 Warning

Diesel engine exhaust and some of its constituents are known to the State of California to cause cancer, birth defects, and other reproductive harm