

WINGET

**OPERATING
INSTRUCTIONS
&
SPARE PARTS
LIST**

**5SEH DIESEL
DUMPER
(CAPACITY 35 CWT)**

ISSUED AUGUST 1978

REPRINTED JULY 2002

WINGET LIMITED
PO BOX 41
EDGEFOLD INDUSTRIAL ESTATE
PLODDER LANE
BOLTON
LANCS
BL4 OLS
TEL: ++ 44 (0) 1204 854650
FAX: ++ 44 (0) 1204 854663
service@winget.co.uk
parts@winget.co.uk
winget.co.uk

INTRODUCTION

This Parts & Operators Manual is a re-print of the manual last published in 1978 and contains some amended part numbers.

Health & Safety legislation and working practices applicable to Site Dumpers, both 2 and 4 wheel Drive, Rigid Chassis and Articulated Chassis have changed considerably in the years since this manual was last published and immediately following this Introduction are notes on the Safe Use of Site Dumpers. These notes supersede and replace all previous 'Dumper Safety' notes issued with Winget 5SEH Two Wheel Drive Dumpers

Reference is made on a number of pages to 'bolt c/w nut and washer', this no longer the case, fixings such as nuts, bolts, screws and washers should be ordered as individual items. A number of Whitworth and B.S.F fixings are now no longer available, in these cases the nearest metric equivalent size will be supplied.

The contents of this manual although correct at the time of publication, may be subject to alteration by the manufacturers without notice and Winget Limited can accept no responsibility for any errors or omissions contained within the following pages. Nor can we accept any liability whatsoever arising from the use of this manual howsoever caused.

Winget Limited operate a policy of continuous product development. Therefore, some illustrations or text within this publication may differ from your machine.

WINGET LIMITED
PO BOX 41
EDGEFOLD INDUSTRIAL ESTATE
PLODDER LANE
BOLTON
LANCS
BL4 OLS
TEL ++ 44 (0) 1204 854650
FAX ++ 44 (0) 1204 854663
E mail service@winget.co.uk
parts@winget.co.uk
www.winget.co.uk

Safety is the responsibility of all persons working with this machine. Think "safety" at all times. ***Read and remember the contents of this handbook.***

The safe working recommendations for specific tasks are found with the instructions for the relevant operation in this Handbook.

MACHINE MODIFICATION

WARNING Any modifications to the machine will affect its working parameters and safety factors. Refer to the Manufacturers before fitting any non-standard equipment or parts.



The Manufacturers accept no responsibility for any modifications made after the machine has left the factory, unless previously agreed by the Manufacturers in writing; the Manufacturers will accept no liability for damage to property, personnel or the machine if failure is brought about due to such modifications, or fitment of spurious parts.

TRAINING

WARNING Only trained operators should use this machine.



Operators should hold an appropriate full motor vehicle driving licence and undergo both a safety awareness course and a driver training course for Site dumpers run by the C.ITB or equivalent body leading to the award of a CTA.

It is strongly recommended that operators read the H.S.E. publication "Safe Working with Small Dumpers" which is available from government bookshops (HMSO) or from other bookshops quoting the following number ISBN 011 8836935. Another useful publication is British Standard number BS 6264, "Procedure for Operator Training For Earth Moving Machinery" available from the British Standard Institution.

RUNNING-IN

WARNING While a gradual 'running-in' of a new engine is not necessary, it is extremely important that the instructions given in *Section 2 "Operation"* on "Running-in a new engine" should be followed very closely during the first fifty hours of operation.



DRIVING

WARNING ***NEVER*** use the machine for purposes other than those for which it was designed. This machine was designed to carry loads such as soil, clay, sand, wet concrete, stone or other similar materials. It was not designed to carry loads which may move around in the skip uncontrollably, nor to carry any loads or materials which overhang the skip in any way. If in any doubt as to the suitability of this machine for a particular task, contact your nearest Distributor or the Manufacturer for advice.



ALWAYS be aware of local and national regulations governing the use of the machine.

NEVER commence work with the machine until the "Daily (or every ten hours)" service checks have been made. (*See Service Section* for details)

ALWAYS check wheel nut tightness daily.

NEVER carry passengers.

Ensure that the seat is securely fixed to the machine. Where seat belt restraints are fitted as part of Rops/Fops protection they must be worn. Check that the seat belt is in good condition, free from cuts and frayed edges.

ALWAYS remain in the driving seat whenever the engine is running. Never attempt to operate any controls unless seated.

ALWAYS apply the parking brake before leaving the driver's seat.

NEVER dismount with the engine running, and never leave the machine unattended with the key in the starter switch.

When Battery Isolators are fitted they must be activated only when the engine is turned off except in cases of emergency.

Activating a Battery Isolator when the engine is running can result in damage to the electrical components and circuits.

NEVER fill the fuel or hydraulic tanks with the engine running.

ALWAYS drive only on surfaces that are known to be stable.

ALWAYS keep the floor plates and walkways clean.

NEVER drive the machine close to the edge of any excavation. Always use effective wheel stops to prevent the machine running close to the edge. Make sure that the stops are in proportion to the size of the wheels and are set sufficiently far enough back from the edge of any excavation to prevent the weight of the load causing a collapse.

NEVER adjust the tyre pressures in an attempt to improve traction on soft ground or obtain a softer ride on hard ground. Incorrectly adjusted tyres can affect the steering and handling characteristics.

NEVER attempt to free a machine which is 'bogged down' by pushing with the bucket of a backhoe loader, tracked excavator or other similar machine.

NEVER make unnecessary "crash stops" when travelling at speed, especially in forward direction.

NEVER work under an unpropped skip. If the dumper was supplied with a special skip support always ensure that it is used.

SKIPS AND LOADING

WARNING NEVER exceed the rated payload. The weights of all loads above skip water level must be checked.



NEVER remain on the machine when loading the skip with excavators or loaders. Stop the engine, apply the parking brake, dismount, and stand well clear.

ALWAYS ensure that the load is evenly distributed in the skip.

NEVER carry loads or heap materials in such a manner as to affect the forward vision.

ALWAYS take extra care when tipping non free running loads.

NEVER use the skip in a tipped position to bulldoze heaped materials level or to backfill material into excavations.

TOWING

WARNING NEVER attempt to start the engine of a dumper by towing or pushing.



Dumpers are not designed as towing vehicles. However, trailers may be towed provided that:

- 1 The combined weight of the trailer and its load does not exceed the dumper "drawbar pull of 250kg (2500N)" and dumper "drawbar load of 50kg (500N)".
- 2 Trailers may be towed in first gear on level dry ground, provided a purpose made towing pin is used.
- 3 The dumper skip must be loaded with half the rated payload to ensure tyre adhesion when braking.

NEVER tow loads up, down or across gradients.

GRADIENTS

WARNING NEVER operate **Two Wheel Drive rigid chassis dumpers** on any gradients which exceed 10% (1 in 10), or across gradients which exceed 10% (1 in 10).



ALWAYS remember that slippery or loose surface conditions can adversely affect safe machine operation, including braking, particularly on gradients.

ALWAYS choose routes that avoid steep, slippery or loose gradients.

NEVER coast down gradients. Always negotiate gradients in first gear.

ALWAYS drive forwards up gradients when loaded.

ALWAYS reverse down gradients when loaded.

ALWAYS keep the load facing uphill.

NEVER park on a gradient. If this is unavoidable, *ALWAYS* chock the wheels.

NEVER attempt to turn on a gradient

NEVER tow up, down or across a gradient.

NEVER operate high discharge or rotating skips on gradients.

HYDRAULICS

WARNING *ALWAYS* "Dump" residual pressure from the system before leaving the machine or before carrying out any maintenance or adjustments.



If maintenance work requires the skip to be in the raised position, then it must be raised and supported before dumping the pressure.

Dump pressure by switching off the engine, then moving the hydraulic control lever several times in each direction.

NEVER leave the machine unattended with pressure in the system.

ALWAYS purge hydraulic rams before commencing work. With the engine running operate the hydraulic control to fully extend and retract the rams.

ALWAYS practise the greatest cleanliness in maintaining hydraulic components.

SERVICING

WARNING *ALWAYS* report any defect at once, before an accident or consequential damage can occur.



ALWAYS conform to service schedules except where:

- 1 Warning lights or warning indicators call for immediate attention.
- 2 Adverse conditions necessitate more frequent servicing.

ALWAYS wear correctly fitting protective clothing. Loose or baggy clothing can be extremely dangerous when working on running engines or machinery.

ALWAYS, where possible, work on or close to engines or machinery only when they are stopped. If this is not practical, remember to keep tools, test equipment and all parts of your body well away from the moving parts.

ALWAYS "Dump" pressure from the hydraulic system before carrying out any kind of maintenance or adjustment. (*see Service - Hydraulic system*).

ALWAYS avoid contact with exhaust pipes, exhaust manifolds and silencers when the engine is running; these can be very hot.

ALWAYS work out of doors, or in a well-ventilated area.

NEVER run an engine in an enclosed space. Exhaust fumes in enclosed areas can kill.

ALWAYS disconnect battery cables and remove battery before using an external charger, carrying out welding repairs or to prevent unauthorised usage when unattended or during a repair.

NEVER allow unqualified personnel to attempt to repair, remove or replace any part of the machine, or anyone to remove large or heavy components without adequate lifting tackle.

NEVER attempt to modify or repair Rops Frames or Fops Canopies by welding, drilling or any other means. Attempts to do so will invalidate Rops/Fops Certification.

ALWAYS obtain advice before mixing oils; some are incompatible. If in doubt drain and refill.

NEVER allow oils and fuels to come into regular contact with skin. This can lead to serious skin diseases including, medical evidence suggests, skin cancer. *ALWAYS* wear protective gloves when handling oils and fuels whether topping up, draining or refilling. *ALWAYS* wash hands if oils or fuels come into contact with the skin.

Many liquids used in this machine are harmful if taken internally or splashed into the eyes. In the event of accidentally swallowing oils, fuels, anti-freeze, battery acid etc, *DO NOT* encourage vomiting, seek qualified medical assistance immediately.

ALWAYS dispose of waste oils and fuels into waste oil storage tanks. If storage tanks are not available consult your distributor or local authority for addresses of local designated disposal points. It is illegal to dispose of waste oil into drains or water courses or to bury it.

Equipment which includes friction materials will sometimes contain asbestos. When removing friction material dust from components, such as when servicing brakes or clutches, do not blow out with an airline; it could be harmful to inhale the dust. Remove the dust with a vacuum cleaner or wipe clean with a damp rag. Waste should be placed in a sealed container, marked, and disposed of in accordance with local or national regulations.

The accumulated dust found in clutch housings may contain lead/antimony. No food should be eaten at a work place contaminated by this dust. Hands must be washed before eating. Do not blow out dust with an airline.

NEVER work under an unpropped skip. ***If the dumper was supplied with a special Skip Support always ensure that it is used.***

ALWAYS ensure that when using a starting handle that it is clean and in good condition. Keep the engine starting dog and the part of the starting handle that mates with it lightly lubricated (*Refer to the Engine Handbook*).

PREPARATION FOR USE

Fig. 1
BEFORE THE DUMPER IS PUT INTO SERVICE, ALWAYS CHECK THE FOLLOWING POINTS.

1. **Engine**
Check the oil level on the dipstick (A), topping up if necessary to the full mark. See also 'Recommended Oils' page 14.
2. **Gearbox**
Check the oil level on the dipstick (B), topping up if necessary to the full mark. See also 'Recommended Oils', page 14.
3. **Drive Axle**
Remove level/filler plug (C) and check that oil is up to bottom of hole. Top up if necessary. See also 'Recommended Oils', page 14.
4. **Fuel Tank**
Fill tank (D) with diesel oil until approximately 1" from the top.

NOTE: Never allow fuel level to fall to below 2" deep in the bottom of the tank.
5. **Hydraulic Tank**
Fill the hydraulic tank (E). Before removing the cap, clean the surrounding area, to prevent the possible entry of foreign matter. DO NOT MIX OILS. See also 'Recommended Oils', page 14.
6. **Brake System**
Ensure that the brake master cylinder reservoir (F) is full of brake fluid. Top up if necessary, to within 1/4" of the top of the reservoir. Use only Girling Crimson Brake Fluid.
7. **Miscellaneous**
Check wheel nuts for tightness.
Check all nuts and bolts for tightness. Loose nuts and bolts may lead to damage not covered by the Dumper Warranty.

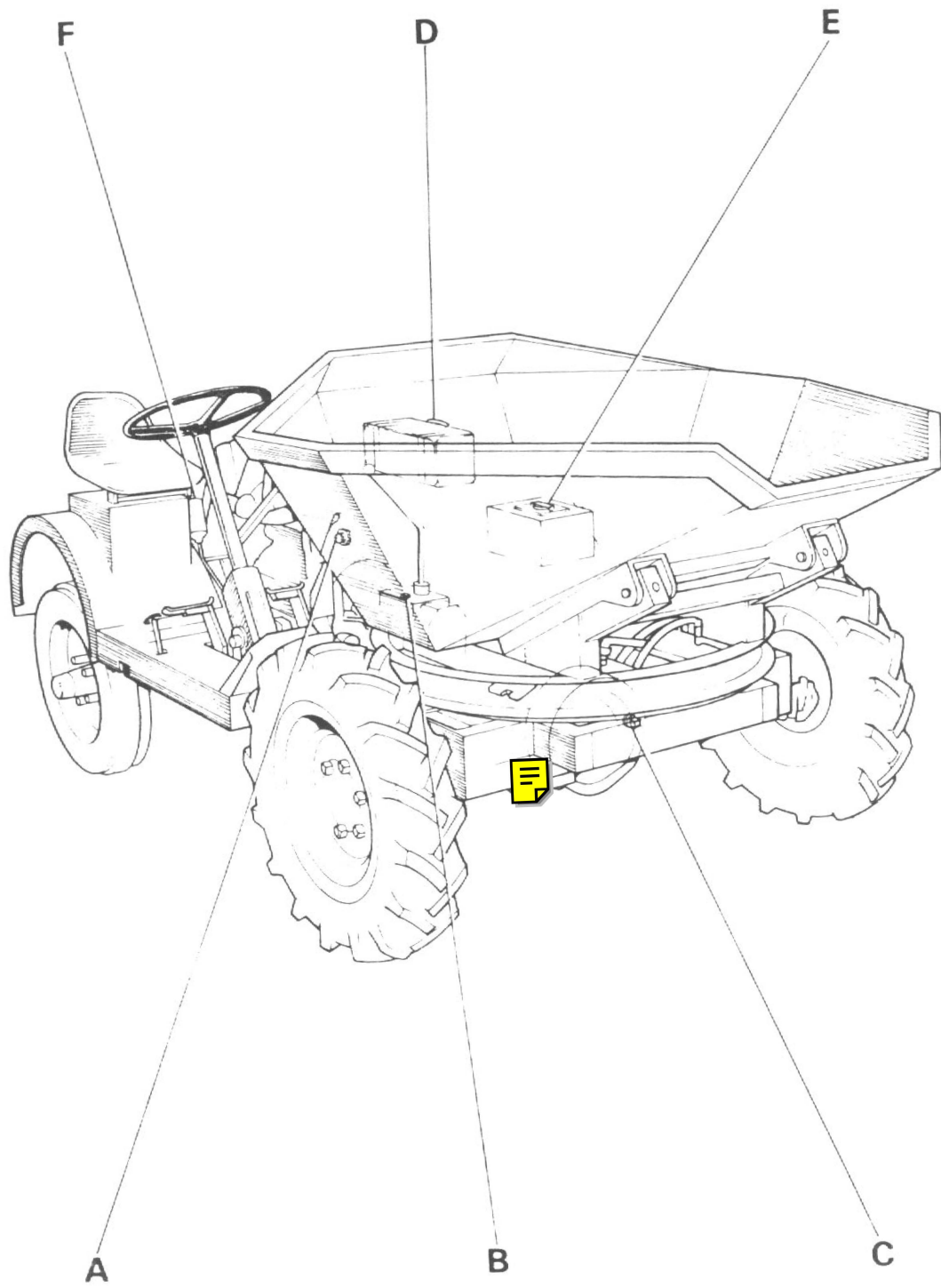

9161

FIG 1

OPERATION

Starting

Fig. 2 & 3

1. Lift red-painted overload stop (A) situated on fuel pump immediately above priming lever (B), and move fuel pump racks (C) into fully-open position. (Petter engine).
2. Operate priming lever (B) six times. (Petter engine).
3. Pull out overload lever (D) and lift to its highest position. (Lister engine).

NOTE: This is unnecessary if engine is already warm.

4. Lift decompression levers (E), positioned on top of engine and turn engine as fast as possible using starting handle. When engine is turning at a good speed, knock down decompression levers and engine should fire.
5. If engine does not fire, lift decompression lever and slowly crank engine a few times before attempting to start again. Where ambient temperature is 5°F (-15°C) or below, a cold starting aid should be fitted.
6. Set overload lever (D) horizontal when engine starts. (Lister engine).

Stopping

Fig. 2

Hold the fuel pump rack (C) in the fully forward position, or lift the priming lever to the horizontal until engine stops and then release. (Petter engine).

Fig. 3

Push overload lever to its lowest position. (Lister engine).

IMPORTANT:

1. DO NOT stop engine by means of decompression levers, this will lead to damaged valve seats and cylinder head joints.
2. DO NOT stop engine by closing fuel tap or by allowing fuel tank to run dry. This will allow air into fuel lines and necessitate bleeding and priming system.

NOTE: Lister engine has self bleeding fuel system:

Gear Shift Lever

Fig. 4

The dumper is fitted with three forward gears and one reverse gear. When changing gear, the clutch pedal is used in the normal manner.

Skip Control Lever

Fig. 5

1. Control lever (A) has three positions DUMP (B), HOLD (C) and RETURN (D).
2. Pull lever up to DUMP (B) to deposit load.
3. Push lever down to RETURN (D) to return the skip to the carrying position.

NOTE: If lever is released when in the DUMP or RETURN positions, it will automatically return to HOLD (C) position and motion of skip will cease. In this way, speed at which load is deposited can be finely controlled.

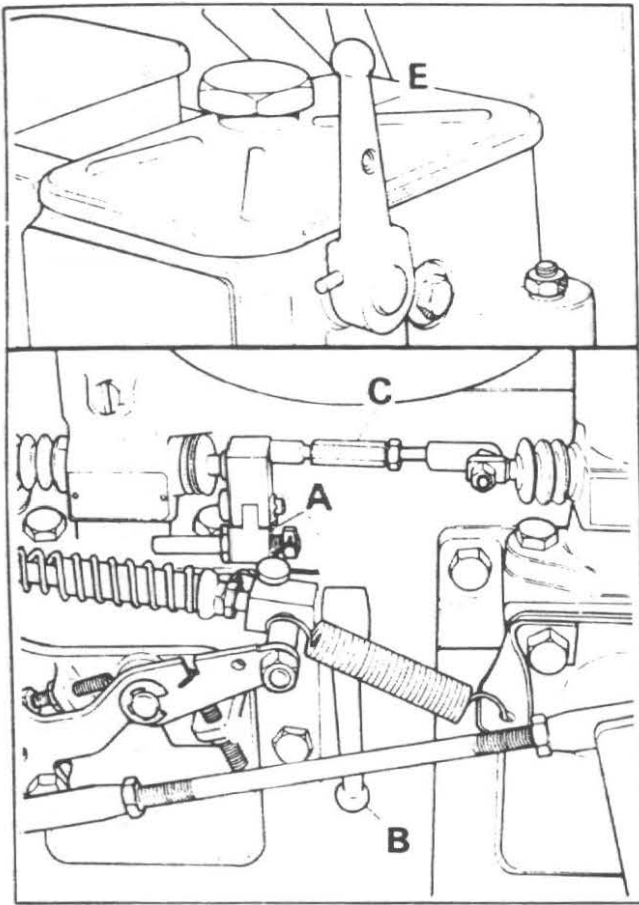

FIG 2

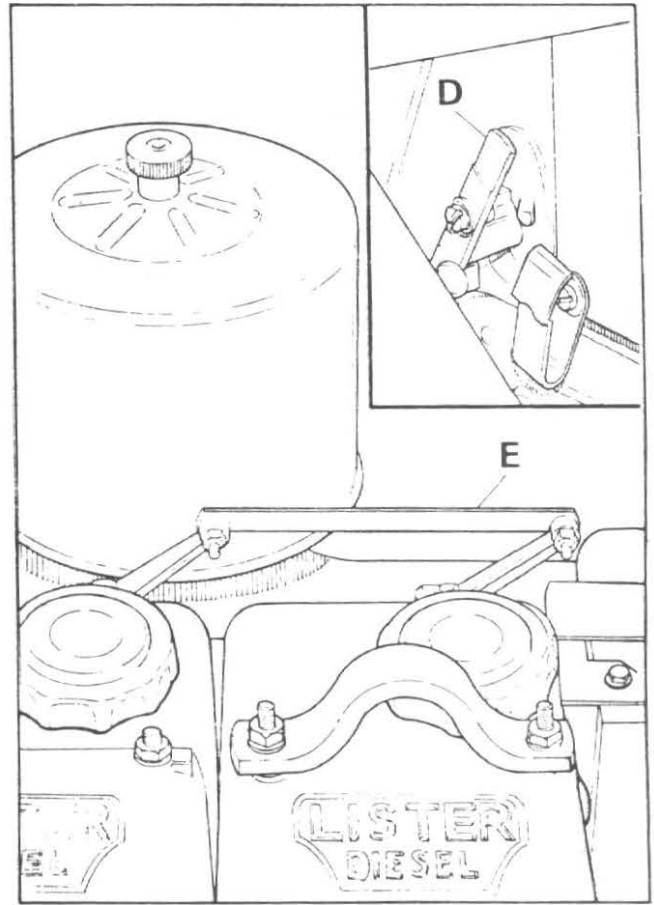

FIG 3

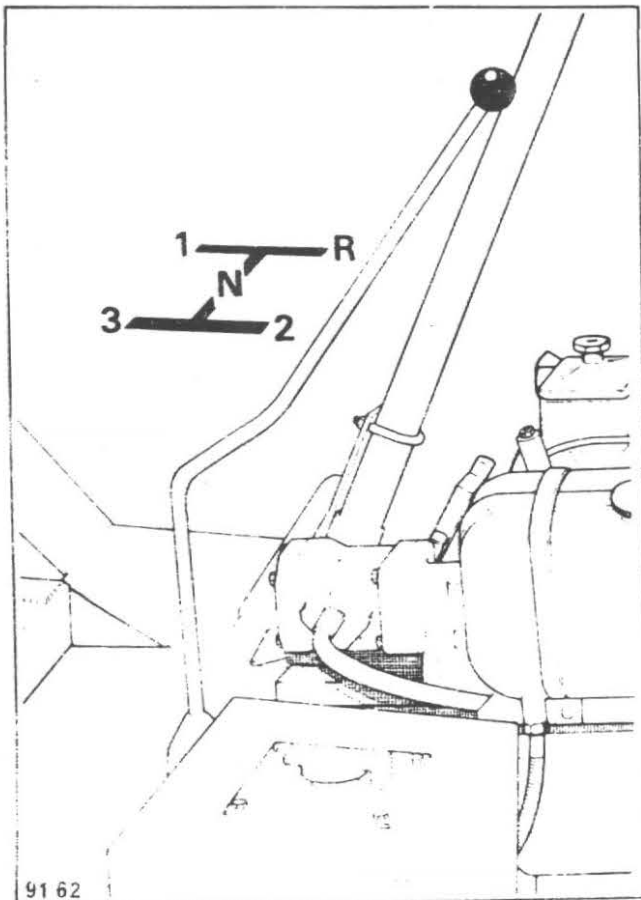

FIG 4

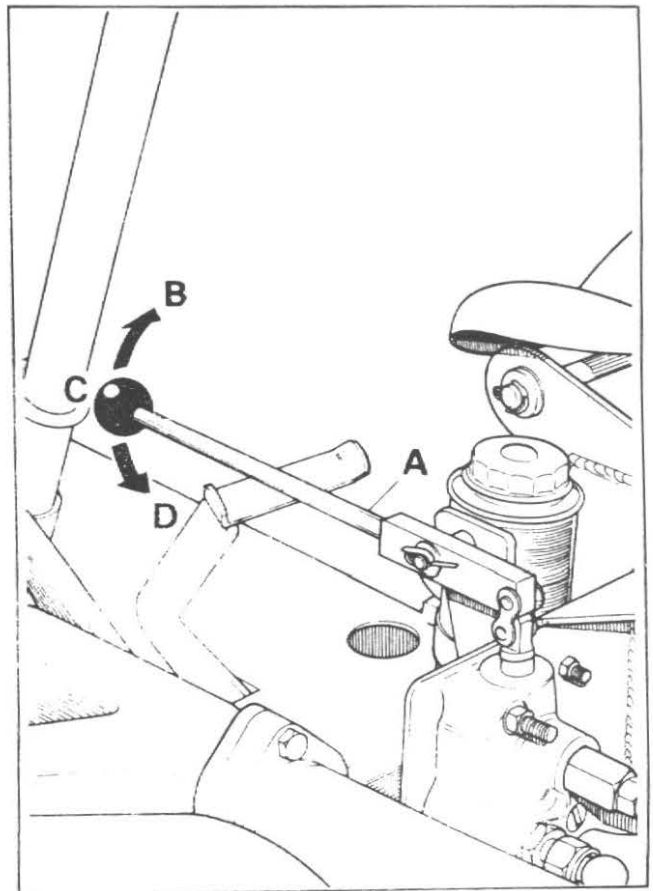
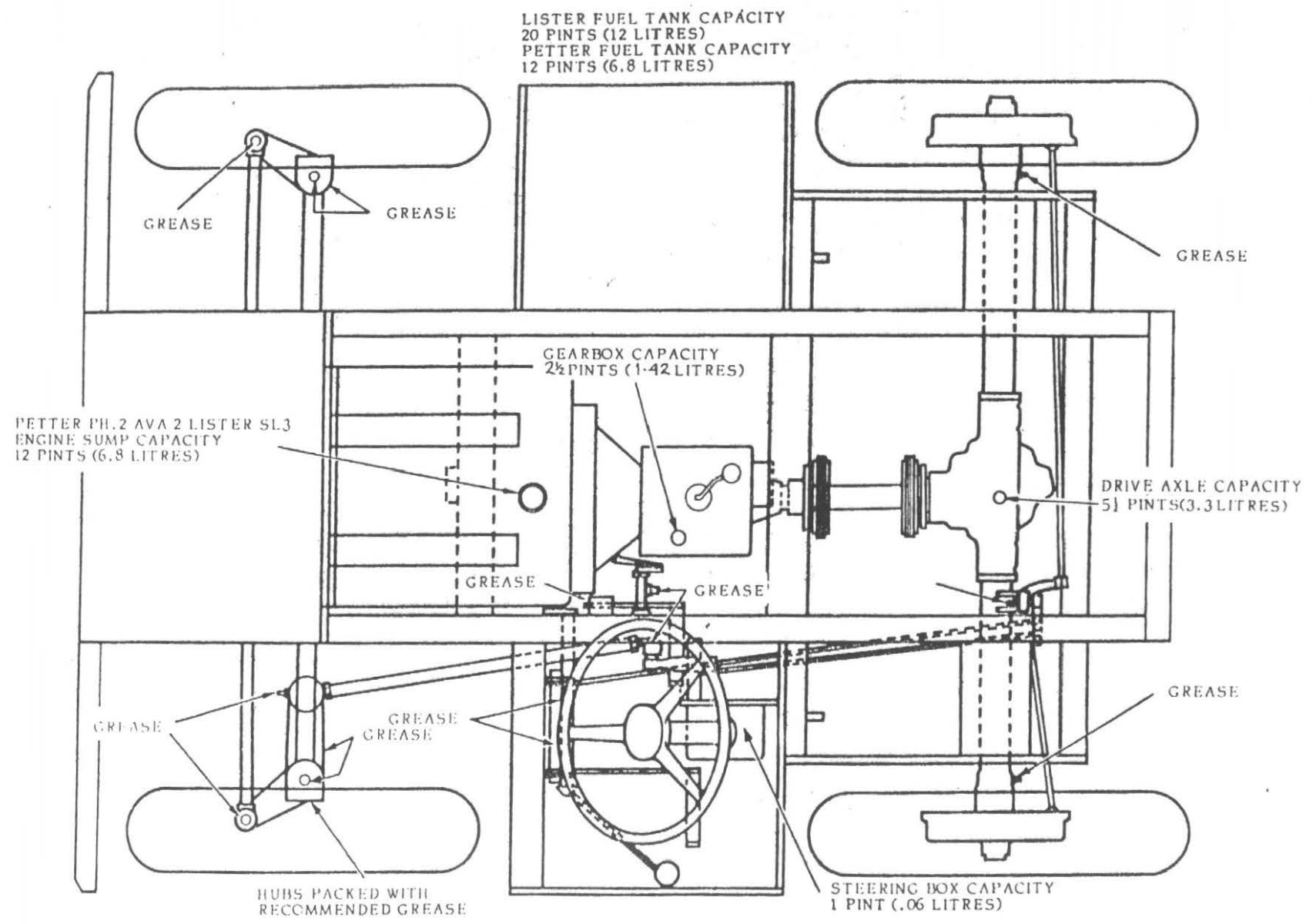

FIG 5









GENERAL MAINTENANCE

Lubrication
Fig. 5

	Daily	No. of points
1	Engine oil	1
2	Fuel Tank	1
	Weekly	
3	Gearbox – oil	1
4	Drive Axle – oil	1
5	Hydraulic Tank – oil	1
6	Brake Master Cylinder Reservoir – brake fluid	1
7	Ram Bearings – grease	4
8	Footbrake Pedal – grease	1
9	Clutch Pedal – grease	1
10	Clutch Cross Shaft – grease	3
11	Steering Axle and Ball Ends – grease	8
12	Steering Box – oil	1
13	Skip Pivot – grease	1

Key

 Engine oil  Gearbox oil  Axle oil  Hydraulic fluid	 Brake fluid  Grease gun  Diesel fuel
---	---

- NOTES:-
1. Rear Axle Articulation Points consist of silentbloc bushes and do not require lubrication.
 2. For full details on the lubrication and maintenance of the engine, refer to the appropriate manufacturer's manual.

Recommended Lubricating Oils

see page 14.

Periodic Maintenance

1. DAILY check engine oil level and fill to full mark on dipstick, if necessary.
2. DAILY fill fuel tank, or as often as proves necessary, to within approximately 1" of top of tank. Never allow there to be a depth of less than 2" of fuel in the tank.
3. WEEKLY check oil level in gearbox and fill to full mark on dipstick, if necessary.
4. WEEKLY remove level/filler plug from drive axle. Oil level should be to bottom of hole. Top up if necessary.
5. WEEKLY check oil level in hydraulic tank. Always clean surrounding area before removing cap, to prevent possible entry of foreign matter. Fill tank if necessary, to within 1" of top.
6. WEEKLY check brake fluid in master cylinder reservoir and top up if necessary, to within 1/4" of top.
7. WEEKLY apply grease to all grease nipples.
8. WEEKLY check all wheel nuts and tighten, if necessary.
9. OCCASIONALLY check all nuts and bolts and tighten, if necessary.

Brake System

The brake system is designed to require the minimum of maintenance, and, providing that the hydraulic fluid in the reservoirs is not allowed to fall below the recommended level no defect should normally occur. Fluid loss must be supplemented by topping up the reservoir with Girling Crimson Brake Fluid. No other fluid may be used. If air is present in the system, it will be indicated by sluggish response of the brake or by spongy action of the brake pedal. This may be due to air being introduced at a loose joint or by the reservoir fluid level being allowed to fall to a very low level. These defects must be remedied immediately and the complete system bled.

To bleed the system, proceed as follows. During the operation it is essential that the reservoir level is kept topped up to prevent further air from being drawn into the system. Only use new fluid for topping-up.

Fig. 6

1. Check that all connections are tight and all bleed screws are closed.
2. Fill reservoir with Girling Crimson Brake Fluid.
3. Attach bleeder tube (A) to bleed screw (B) of one wheel and immerse other end in a small quantity of brake fluid contained in a glass jar (C). Slacken bleed screw and operate brake pedal up and down through its full stroke until fluid pumped into jar contains no air bubbles. Hold down pedal and close bleed screw. Remove bleeder tube and release pedal.
4. Repeat on other wheel.
5. Lock both bleed screws and top up reservoir to correct level.
6. Apply normal working load on brake pedal for two or three minutes and examine entire system for leaks.

Main Hydraulic System

The main hydraulic system controls the dumping and return of the skip. If the skip fails to operate or does so extremely slowly, carry out the following procedures until the fault is rectified.

1. Check that hydraulic tank is full of oil.

Fig. 7

2.
 - a) Remove four setscrews (A) securing filler cap assembly (B) and remove assembly
 - b) Unscrew suction filter (C) from inside of tank (D) and wash in white spirits. Dry with moisture-free compressed air.
 - c) Replace suction filter and filler cap assembly.

NOTE: If suction filter cannot be thoroughly cleaned, fit a new one.

3. Check that hydraulic pressure is correct.
 - a) Fit a 2500 p.s.i. gauge into hydraulic line to base of rams.
 - b) Operate control lever to dump skip and check that pressure reading on gauge is 2000 p.s.i. when ram is fully-extended and relief valve is 'blowing'.

Fig. 8

4. Remove relief valve cartridge (A) (hexagon head) from end of control valve (B) opposite to control lever
5. Remove hose adaptor (C) from control valve, remove hexagonal orifice plate (D) and wash in white spirit. Dry using moisture-free compressed air. DO NOT poke wire, etc. into orifice. Re-fit plate and hose adaptor, with slot of orifice plate facing outwards.

If none of these procedures correct the fault, contact your local Winget agent

Periodically check the hose between the pump and the hydraulic tank to ensure that it is not deformed. Any deformation in the hose may result in a flow and damage the pump.

SERVICE PROCEDURE FOR DISC BRAKES

The disc brakes fitted to the dumper are self-adjusting on the footbrake.

The operating rods actuating the handbrake section of the brakes should not be altered in length to effect adjustment.

Should there be any tendency for the footbrake line pressure to build up and thereby causing the footbrake pads to remain 'hard on' the discs, this is invariably due to the master cylinder piston being prevented from travelling its full return stroke.

Adjustment is made by turning the clevis end fitted to the master cylinder piston rod, until a clearance of $\frac{1}{8}$ " is obtained between the brake pedal and the edge of the drivers footplate when the clevis end is refitted to the brake lever. NOTHING SHOULD RESTRICT THE RETURN OF THE BRAKE PEDAL.

The brakes are 'bled' in the usual automotive method until all air is expelled from the system. Ensure that the header tank is kept full at all times, and that the master cylinder piston travels its full operating stroke during the 'bleeding procedure'.

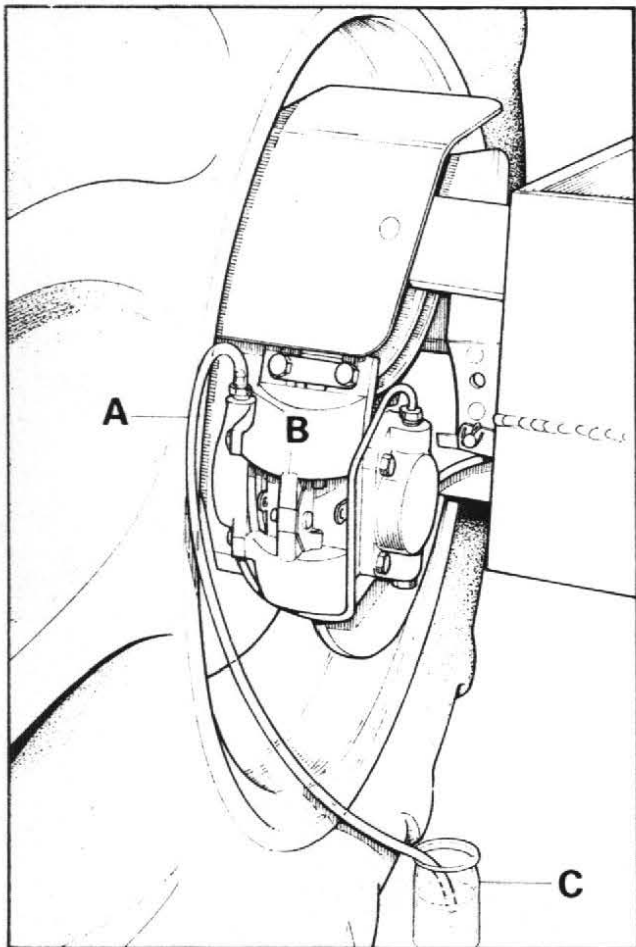

FIG 6

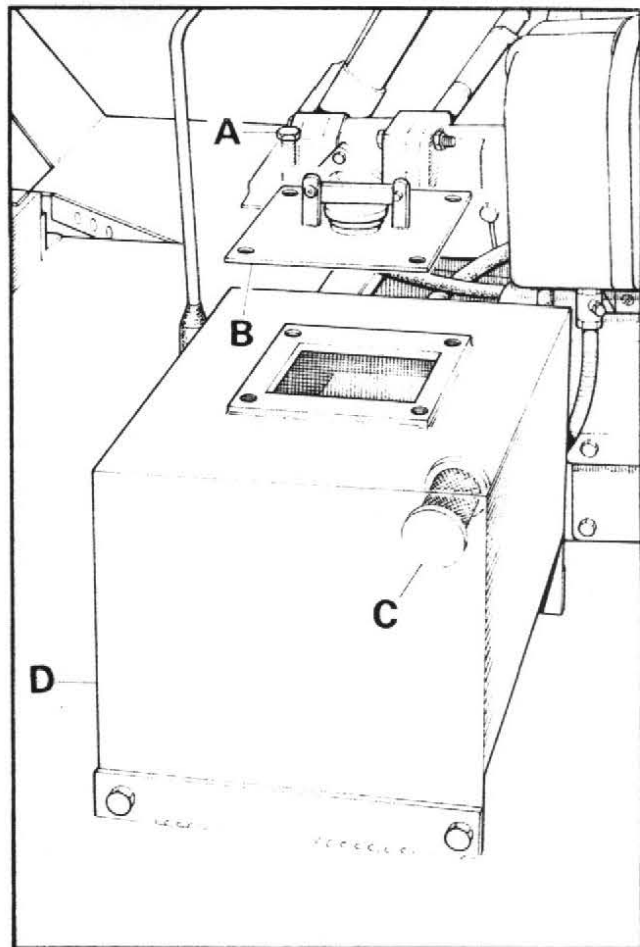

FIG 7

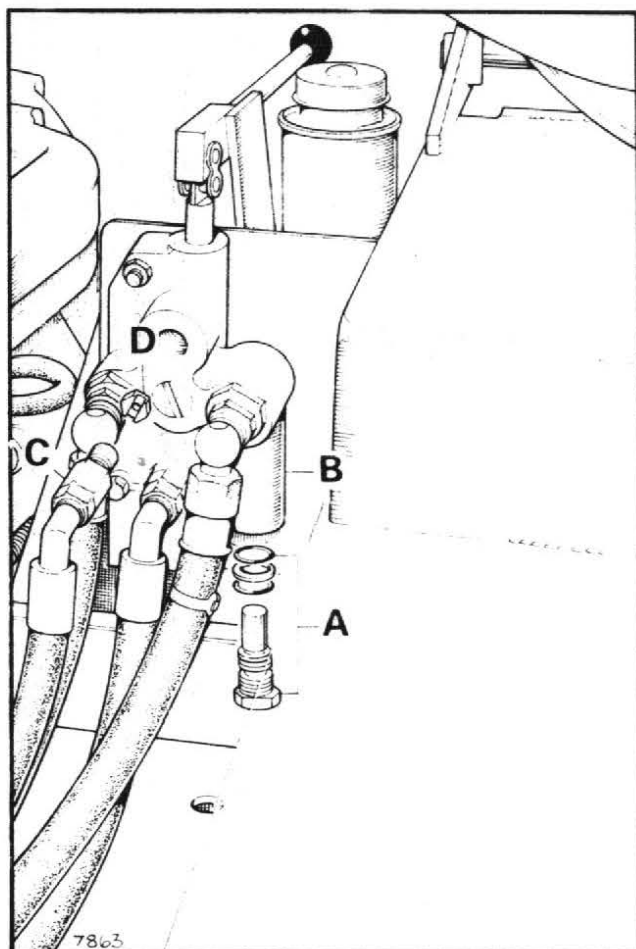
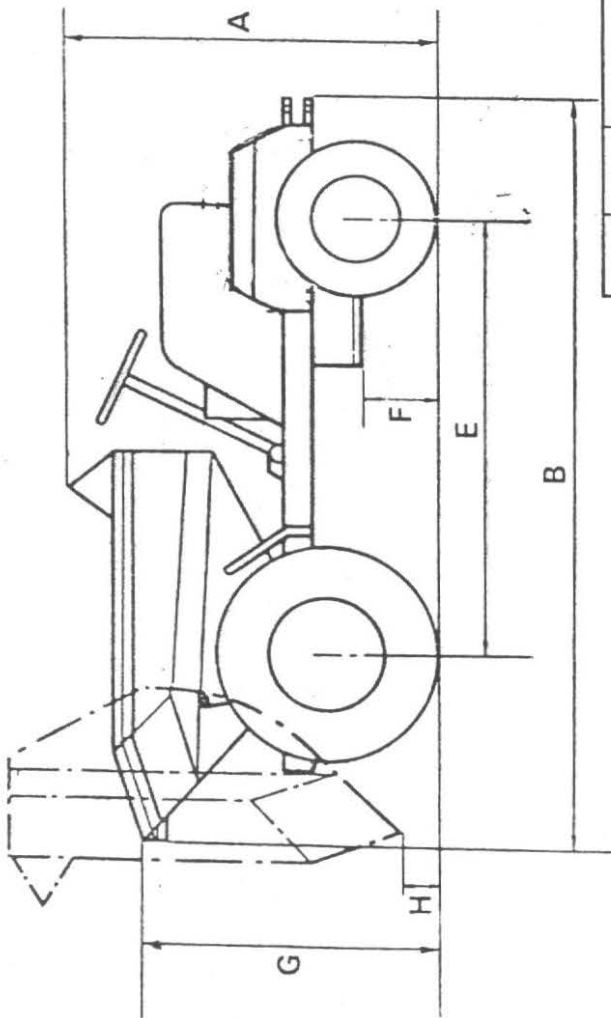
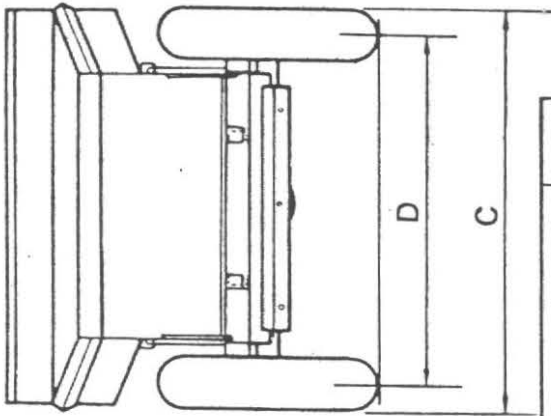
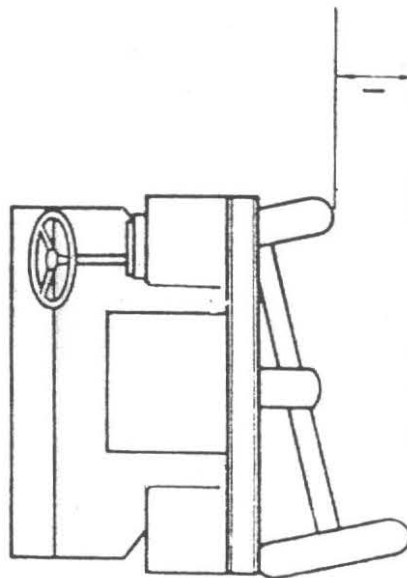

FIG 8



DIMENSIONS		Ft.	Ins.
A	OVERALL HEIGHT	4	10
B	OVERALL LENGTH	10	5
C	OVERALL WIDTH	5	7
D	TRACK	4	8½
E	WHEEL BASE	5	9
F	GROUND CLEARANCE		10½
G	LOADING HEIGHT	4	0
H	DISCHARGE HEIGHT		3½
I	ARTICULATION	1	2
J	TURNING CIRCLE	27	0
SKIP CAPACITIES:-		Ft³	
WATER CAPACITY		33	
STRUCK CAPACITY		37	
HEAPED CAPACITY		44	
NETT WEIGHT		26¾ Cwt.	
MAX. PAYLOAD		3920 lbs (1778 kgs.)	



RECOMMENDED LUBRICATING OILS

COMPANY		ENGINE	DRIVE AXLE TRANSFER BOX & STEERING BOX	GEARBOX	WHEEL BEARINGS & OTHER GREASE POINTS	HYDRAULIC SYSTEM
(U.K.) ESSO	SUMMER WINTER	ESSOLUBE HDX 20W	GEAR OIL GP85W/140	ESSOLUBE HDX 30	BEACON 2	NUTO H32
	ABOVE 32 ^o 0-32 ^o BELOW 0 ^o C (Overseas)	ESSOLUBE HDX 30 ESSOLUBE HDX 20W ESSOLUBE HDX 10W	GEAR OIL GP 85W/140 GEAR OIL GP 85W/140 GEAR OIL GP 80W	ESSOLUBE HDX 30	BEACON 2	NUTO H68 NUTO H32 NUTO H22
(U.K.) CASTROL	SUMMER WINTER	DEUSOL CRB 20	DEUSOL GEAR EP 90	DEUSOL CRB 30	CASTROL SPHEEROL APT 2	CASTROL HYSPIN AWS 32
	ABOVE 32 ^o 0-32 ^o BELOW 0 ^o C	DEUSOL CRB 30 DEUSOL CRB 20 DEUSOL CRB 10	DEUSOL GEAR EP 140 DEUSOL GEAR EP 90 DEUSOL GEAR EP 80	DEUSOL CRB 30	CASTROL SPHEEROL APT 2	
(U.K.) SHELL	SUMMER WINTER	ROTELLA SX OIL 20/20W	SPIRAX 90 EP	ROTELLA SX OIL 30	RETINAX A	TELLUS OIL 37
	ABOVE 32 ^o 0-32 ^o BELOW 0 ^o C (Overseas)	ROTELLA SX OIL 30 ROTELLA SX OIL 20/20W ROTELLA SX OIL 10W	SPIRAX 140 EP SPIRAX 90 EP SPIRAX 80 EP	ROTELLA SX OIL 30	RETINAX A	
(U.K.) BP	SUMMER WINTER	VANELLUS M20W	GEAR OIL SAE 90 EP	VANELLUS M30	ENERGREASE L2	ENERGOL HLP 65
	ABOVE 32 ^o 0-32 ^o BELOW 0 ^o C (Overseas)	VANELLUS M30 VANELLUS M20W VANELLUS M10W	GEAR OIL SAE 140 EP GEAR OIL SAE 90 EP GEAR OIL SAE 80 EP	VANELLUS M30	ENERGREASE L2	
(U.K.) MOBIL	SUMMER WINTER	DELVAC 1220	MOBILUBE HD 90 MOBILUBE GX 90	DELVAC 1230	MOBILGREASE MP MOBILGREASE SUPER	DTE 24
	ABOVE 32 ^o 0-32 ^o (Overseas)	DELVAC 1230	MOBILUBE HD 140 MOBILUBE GX 140			
	BELOW 0 ^o C ALL TEMPERATURES	DELVAC 1220 DELVAC 1210 DELVAC SPECIAL 10W-30	MOBILUBE HD 90 MOBILUBE GX 90 MOBILUBE HD 80 MOBILUBE GX 80	DELVAC 1230		
(U.K.) WALKERS CENTURY	SUMMER WINTER	CENTLUBE HD 20	CENTURY EP 90	CENTLUBE HD 30	REGULUS A2	CENTURY PWLA HYD OIL
	ABOVE 32 ^o 0 ^o C-32 ^o BELOW 0 ^o C (Overseas)	CENTLUBE HD 30 CENTLUBE HD 20 CENTURY ROIL 10W	CENTURY EP 140 CENTURY EP 90 CENTURY EP 80	CENTLUBE HD30	REGULUS A2	CENTURY PWLA HYD OIL

IN THE UNLIKELY EVENT OF THE ABOVE OILS NOT BEING AVAILABLE
EQUIVALENT OILS SUPPLIED BY A REPUTABLE MANUFACTURER MAY BE USED

SPARE PARTS SECTION

LIST OF CONTENTS

TITLE	PAGE NO.
CHASSIS	20-21
SKIP & FRAME	22-23
CLUTCH ASSEMBLY	24
GEARBOX	25-28
DRIVE AXLE SALISBURY 5HA-001-239	29-32
PROPSHAFT & COUPLING	33
DRIVE WHEELS/FRONT 10.5 X 18	34
STEERING WHEELS/REAR	35
STEERING AXLE	36-37
STEERING GEAR (CAM & ROLLER)	38-39
PEDALS & CONTROLS	40-41
HANDBRAKE ASSEMBLY	42
BRAKE CALIPER	43
BRAKE PIPES & FITTINGS	44
MASTER CYLINDER	45
HYDRAULIC HOSES & FITTINGS	46-47
TIPPING CYLINDER	48-49
HYDRAULIC PUMP	50-51
HYDRAULIC CONTROL VALVE	52-53
ELECTRICAL SYSTEM	54

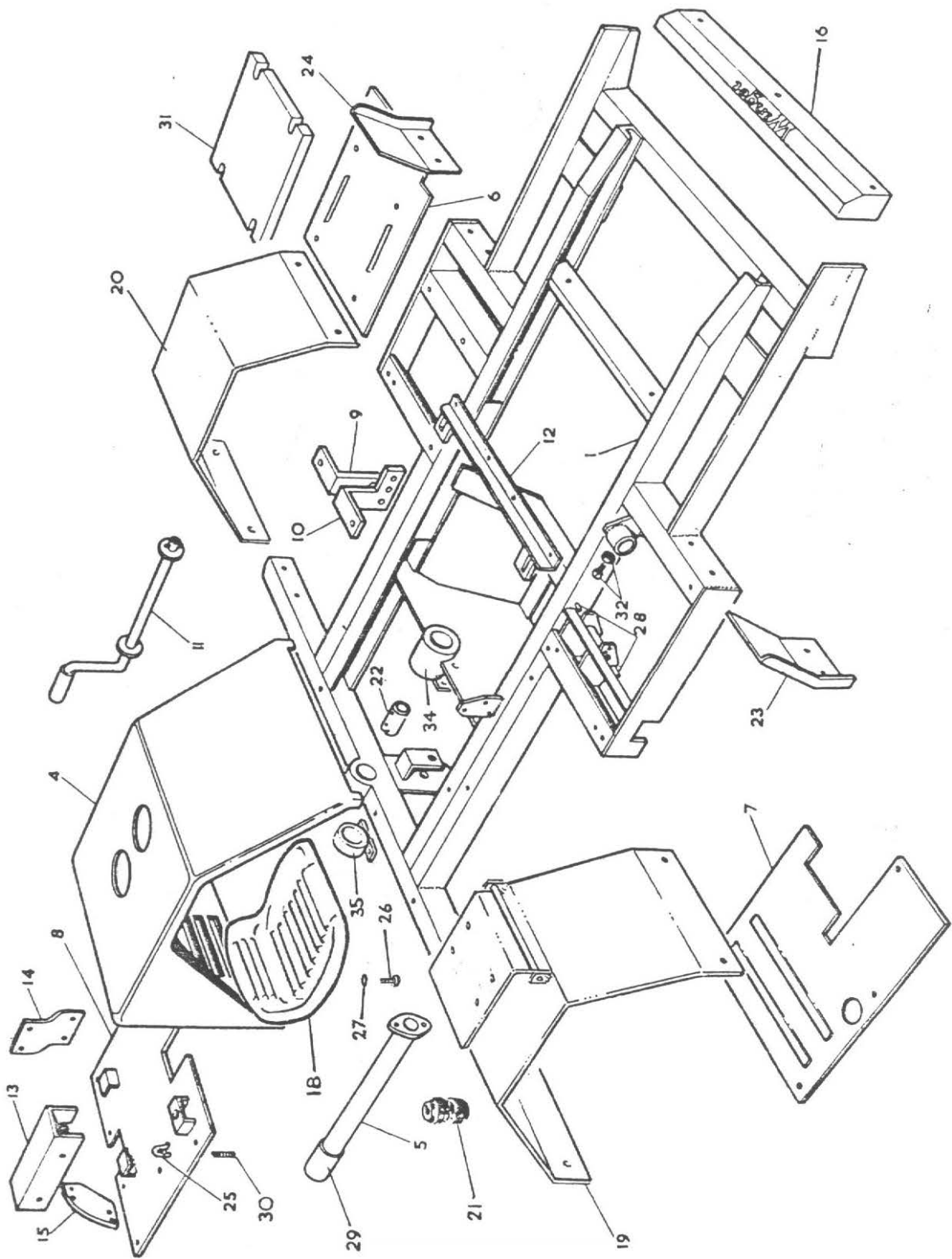

Item No.	Part No.	Description	Qty.
1	40249.A01	Chassis Frame (Petter)	1
	40249.A02	Chassis Frame (Lister)	1
2			
3			
4	40238.A01	Engine Cover (Petter)	1
	40238.A02	Engine Cover (Lister)	1
5	5S.111	Exhaust Pipe (Petter)	1
6	F.529	Footplate (L.H. Side)	1
7	4S.105	Footplate (Driver's Side)	1
8	4S.109	Footplate (Rear) (Petter)	1
	4S.124	Footplate (Rear) (Lister)	1
9	4S.104	G/Box Support L.H.....	1
10	4S.104A	G/Box Support R.H.....	1
11	F.534	Starting Handle	1
12	5S.110	Engine Cover Support (Petter)	1
	5S.123	Engine Cover Support (Lister)	1
13	F.539	Engine Fuel Tank Support (Top) (Petter)	1
14	F.540	Engine Fuel Tank Support (Bottom) (Petter)	1
15			
16	C.147	Ballast Weight (Front)	1
17			
18	20072.A01	Seat	1
19	40220.A05	Mudwing (Driver's Side)	1
20	40220.A02	Mudwing (L.H.)	1
21	10519.A01	Seat Spring (Rubber)	1
	11S.04C	Screw - M10 x 25 (Spring Fixing)	1
	61S.04	Nut - M10 (Spring Fixing)	1
	C.180B	Washer (Special) (Spring Fixing)	1
22	L.259L	Starter Dog (Lister)	1
	L.259R	Starter Dog (Petter)	1
23	L.283RH	Mudflap R.H.....	1
24	L.283LH	Mudflap L.H.....	1
25	L.287A	Starting Handle Clip	1
26	69S.2C	Setscrew (Seat Fixing)	4
27	41S.4A	Washer (Seat Fixing)	4
28	WB.0808	Bush - Accelerator	2
29	5S.111/B	Exhaust Socket (Petter)	1
30	L.256/C	Spring (Starting Handle Clip)	1
31	C.181	Ballast Weight (Side)	1
32	C.212	Grub Screws c/w Locknuts (Steering Column)	2
33	4S.100B/21A	Starter Dog Shroud	1
34	4S.123/2	Starting Handle Guide (Rear) (Lister)	1
	11S.04D	Screw - M10 x 30 (Wing Fixing)	8
	7S.04	Nut - M10 (Wing Fixing)	8
	17S.05	Washer - M10	8

When an electric start Petter engine is fitted the following item changes occur:-

Item No.	New Part No.	Description	Qty.
4	10934A01	Engine cover	1

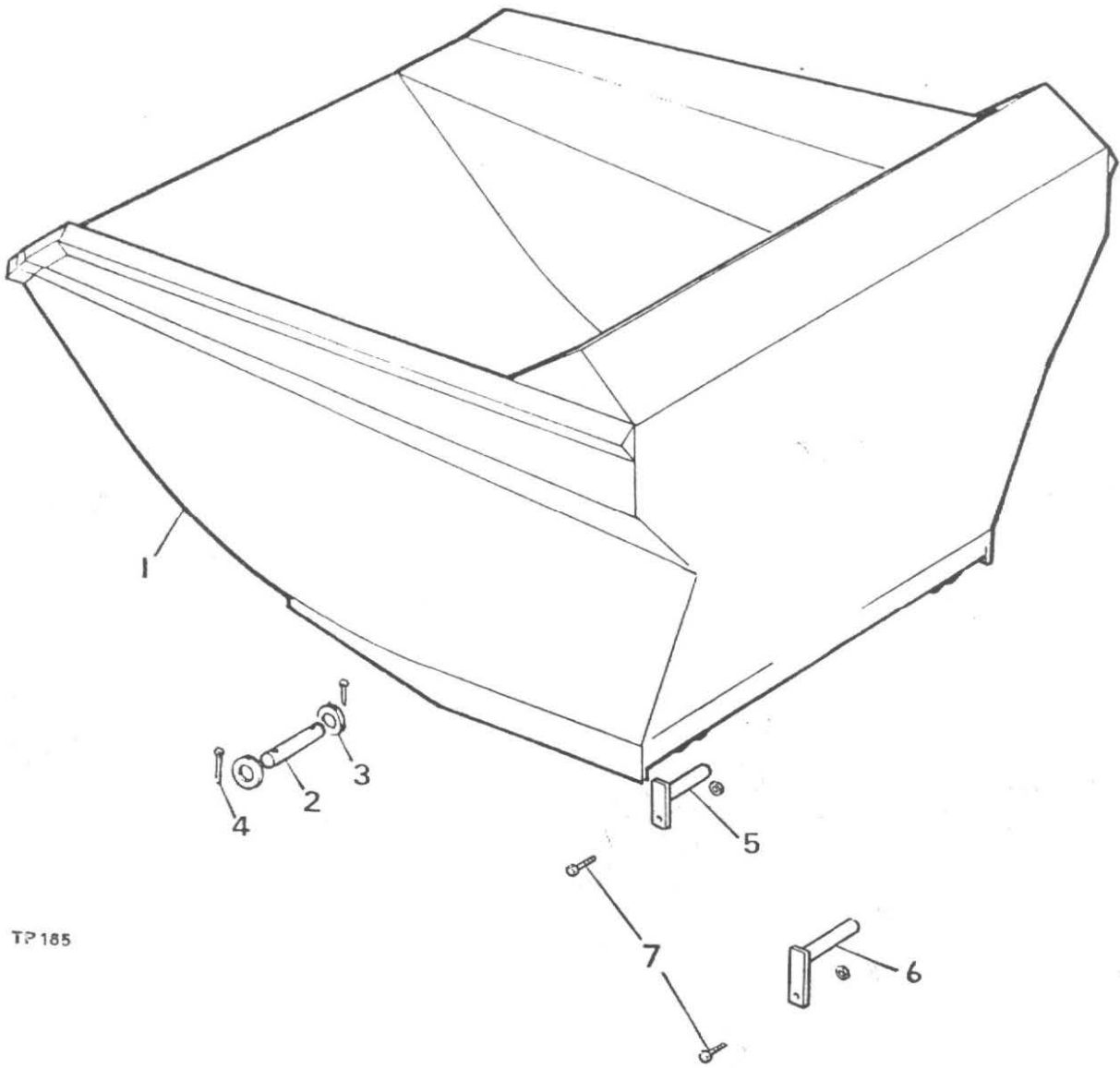

TP165

SKIP & RELEASE LEVER

Item No.	Part No.	Description	Qty
1	5SH 61	Skip	1
2	3SH-65	Skip pivot pin	2
3		Flat washer $\frac{7}{8}$ " dia.	AR
4		Split pin $\frac{3}{16}$ " dia.	4
5	3SH-83	Ram pivot pin (skip end).....	2
6	3SH 84	Ram pivot pin (chassis end).....	2
7		Bolt M8 x 30mm long & Self Lock nut & Washer.....	4

FLYWHEEL AND CLUTCH ASSEMBLY

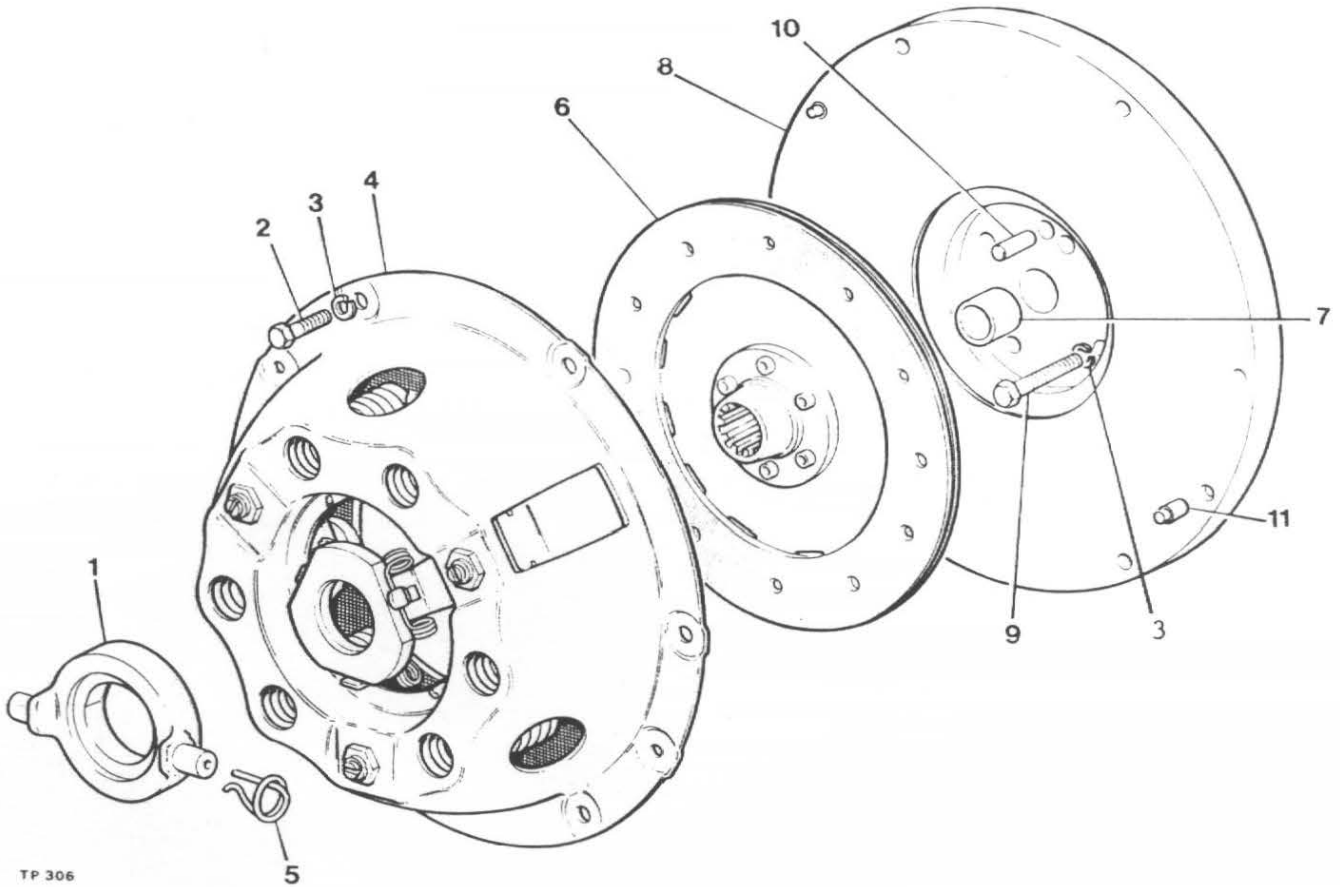

TP 306

Item No.	Part No.	Description	Qty.
1	10579A01	Clutch Release Bearing	1
2	28S02D	Screw Set	6
3	41S04	Washer Spring	10
4	10597A01	Cover Assembly	1
5	10579A101	Retainer Spring	2
6	10598A02	Drive Plate	1
7	10580A0101	Bush	1
8	10580A02	Flywheel Assembly (comprises of items 7, 8, & 11)	1
9	1S02C	Bolt, Petter PH Engine (drill for locking wire)	4
9A	6S02B	Bolt, Lister Engine (drill for locking wire)	4
10	C321	Dowel	1
11	10580A0102	Dowel	2
	10948A02	Clutch Kit (comprises of items 1, 4, 5 & 6)	1

It is recommended that instead of drilling the head of the bolts (item 9) for locking wire that one of each of tabwashers part no's 10531A02 and 10531A03 are used to prevent the bolts working loose.

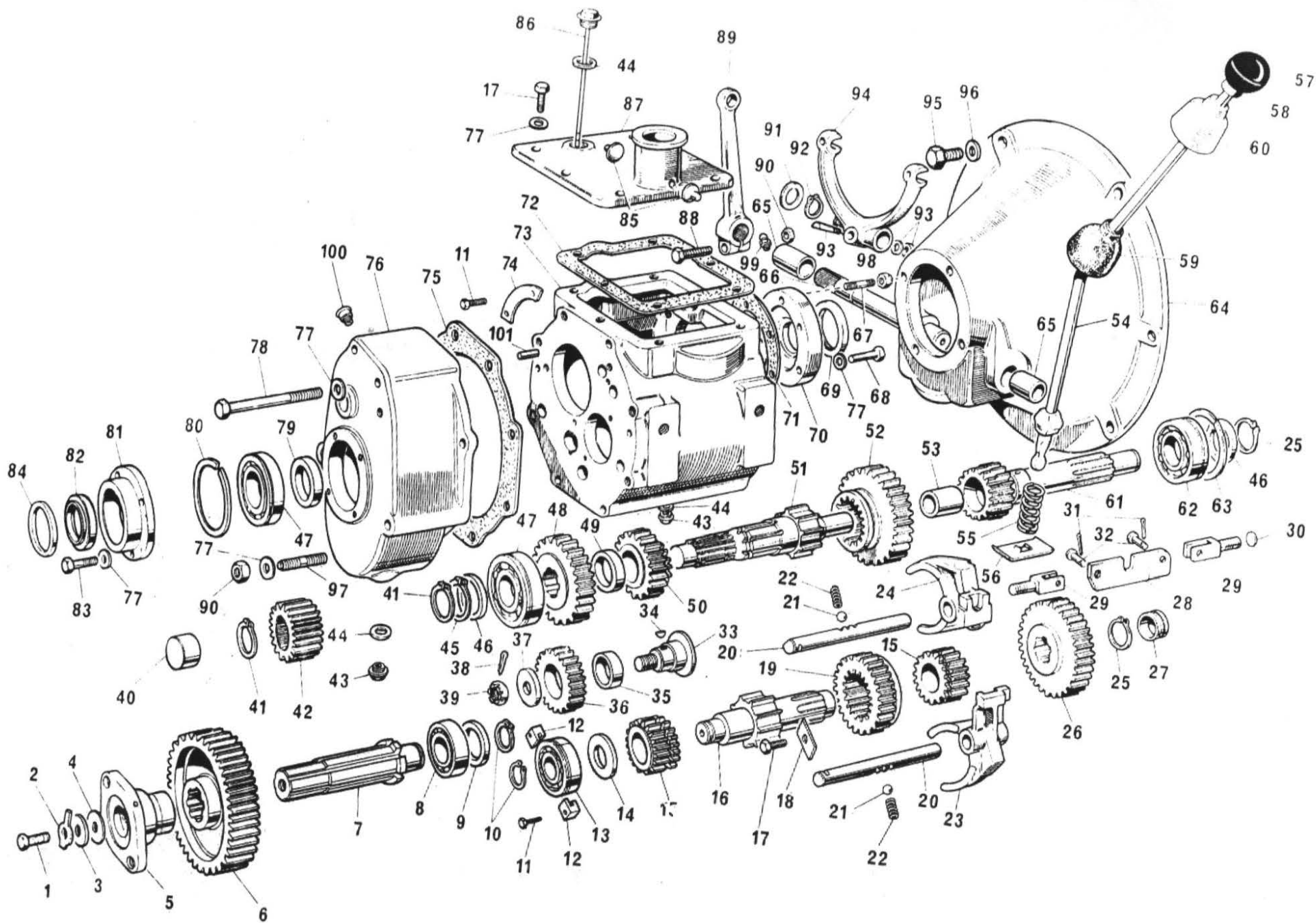

GEARBOX 40M/824

Item No.	Part No.	Description	No. Of
1	USF55	Screw, Coupling	1
2	CM2050	Lockwasher	1
3	CM2123	Washer, Coupling	1
4	40M/340	Washer, Fibre	1
* 5	40M/383	Flange, Drive (Type 70) 9/16" Bolts	1
6	40M/316	Gear, Driven	1
7	40M/313	Shaft, Output	1
8	40M/327	Bearing	1
9	40M/325	Spacer, Bearing	1
10	40M/148	Circlip	2
11	USF11	Screw, Bearing Retaining	3
12	40M/299	Clip, Layshaft Bearing	2
13	40M/146	Bearing, Rear Layshaft	1
14	40M/130	Spacer, Bearing	1
15	40M/114	Gear, Reverse Speed	2
16	40M/118	Layshaft	1
17	USF21	Screw, Top Cover & Lock Strip	13
18	40M/136	Strip, Locking (Selector)	1
19	40M/116	Gear, Second Speed Sliding	1
20	40M/135	Shaft, Selector	2
21	CP1077	Ball, Detent (CM2051 Prior To S/NO 4616)	2
22	CM2103	Spring, Detent	2
23	40M/501	Fork, Selector (First & Reverse)	1
24	40M/502	Fork, Selector (Second & Third)	1
25	CM2053	Circlip, Primary Shaft	3
26	40M/360	Gear, First Reduction	1
27	40M162	Bush, Layshaft	1
28	40M/505	Plate, Interlock	1
29	40M/231	Stud, Interlock	2
30	CM2113	Disc, Sealing	3
31	40M/244	Split Pin, Interlock	2
32	40M/232	Clevis Pin, Interlock	2
33	40M/119	Shaft, Reverse Pinion	1
34	40M/222	Key, Reverse Pinion Shaft	1
35	40M/161	Bush, Reverse Pinion	1
36	40M/111 S/A	Pinion, Reverse C/W Item 35	1
37	40M/155	Washer, Reverse Pinion Shaft	1
38	CP1004	Pin, Split	1
39	UN507	Nut, Reverse Spindle	1
40	40M/346	Roller, Needle	1
41	40M/347	Circlip	2
42	40M/350	Gear, Drive	1
43	CP1002	Plug, Drain	2
44	CP1068	Washer, Drain Plugs & Dipstick	3
45	40M/348	Circlip	1
46	40M/174	Spacer, Bearing	2
47	CM2052	Bearing, Rear Mainshaft	2
48	40M/110	Gear, Output	1
49	40M/128	Spacer, Output Shaft	1
50	40M/113	Gear, Second Speed	1
51	40M/345	Shaft, Main	1
* 5A	40M223	Drive Flange (1/2" Bolts)	1

SEE NOTE
BELOW

(CM2051 Prior To S/NO 4616)

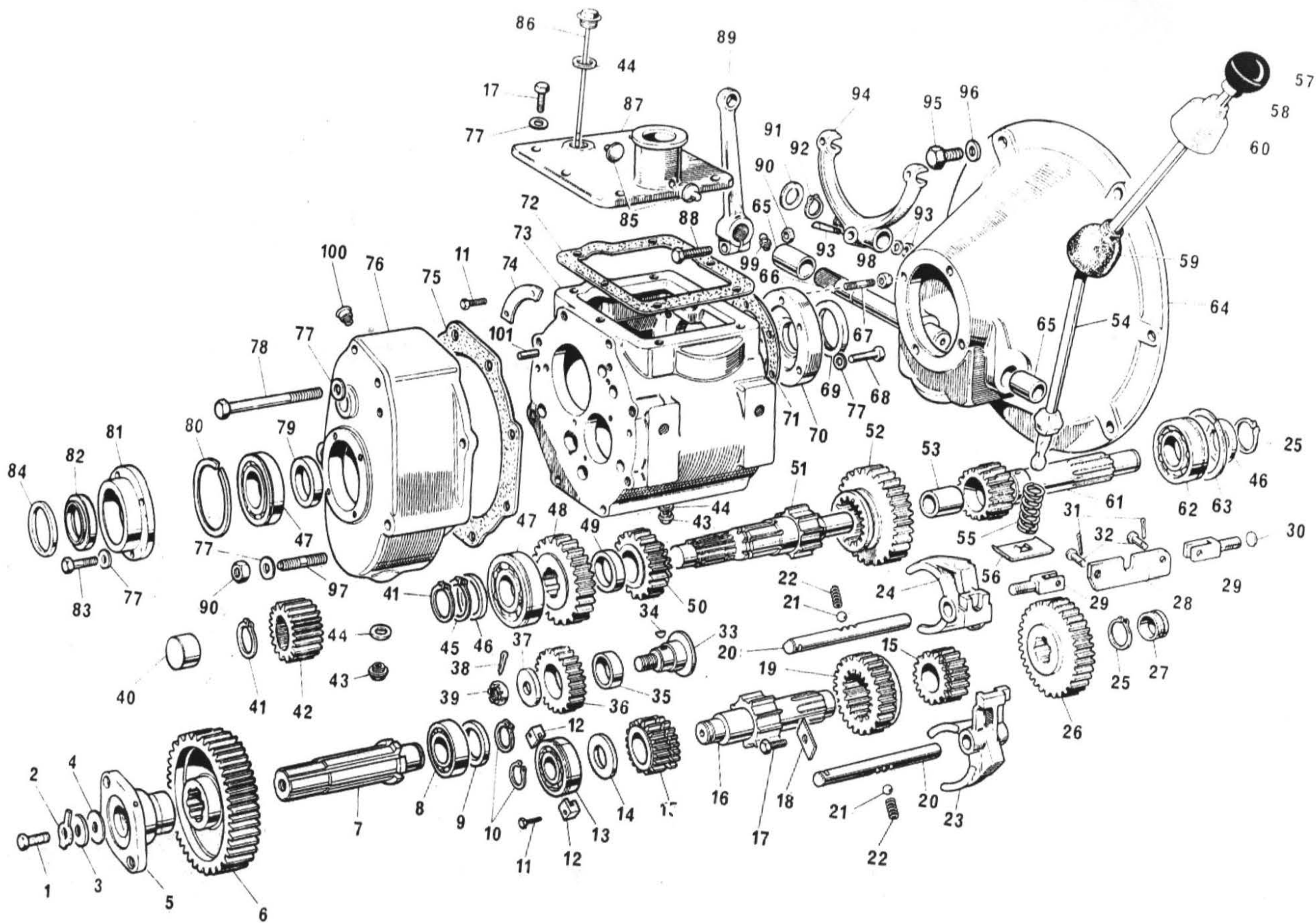

GEARBOX 40M/824

Item No.	Part No.	Description	No. Off
52	40M/115	Gear, First Speed	1
53	40M/513	Bearing, Primary Shaft	1
54	40M/334A	Lever, Gear	1
55	40M/367	Spring, Gear Lever	1
56	40M/245	Plate, Gear Lever Retaining	1
57	40M/133	Knob, Gear Lever	1
58	UN512	Nut, Gear Lever	1
59	40M/129	Cover, Gear Lever	1
60	40M/377	Cover, Protective	1
61	40M/117 S/A	Shaft, Primary C/W Item 53	1
62	40M/143	Bearing, Input	1
63	40M/252	Ring, Snap	1
64	40M/392	Housing, Clutch	1
65	CM2179	Bush, Clutch Cross Shaft	2
* 66	40M/394	Cross Shaft, Clutch SEE NOTE BELOW	1
67	40M/177	Stud	6
68	UBF71	Bolt, Front Cover	4
69	40M/150	Oil Seal, Input	1
70	40M/126	Cover, Front	1
71	40M/172	Joint, Front Cover	1
72	40M/169	Joint, Top Cover	1
73	40M/101/N	Casing, Gearbox	1
74	40M/141A	Retainer, Large Bearing	1
75	40M/661	Joint, Reduction Housing	1
76	40M/660	Housing, Reduction	1
77	W104	Washer, Front Cover, Top Cover Lock Strip & Reduction Housing	25
78	UBF19L	Bolt, Reduction	4
79	40M/320	Spacer, Output Shaft	1
80	CM2060	Retainer, Bearing	1
81	40M/622 S/A	Housing, Rear Oil Seal C/W Item 82	1
82	40M/167	Oil Seal, Rear	1
83	USF3L	Screw Reduction Housing	8
84	CM2201	Excluder, Dust	2
85	40M/254	Pad, Gear Lever	2
86	40M/153	Dipstick	1
87	40M/220	Cover, Gearbox	1
88	UBF91	Bolt, Clutch Lever	1
89	CM2090	Lever Clutch Release	1
90	UN501	Nut, Clutch Lever & Reduction Housing	3
91	40M/398	Washer, Cross Shaft	1
92	CP1006	Circlip, Cross Shaft	1
93	CM2084/SA	Cotter, Nut & Washer	1
94	CM2083	Fork, Clutch Release	1
95		Bolt	6
96		Washer	6
97	40M/329	Stud	2
98	UNL106	Nut, Clutch Housing	6
99	CP1069	Nipple, Grease (Straight)	1
100	CM2106	Breather	1
101	40M/656	Dowel	1
* 66A	40M 158	Clutch Cross Shaft (old type)	1

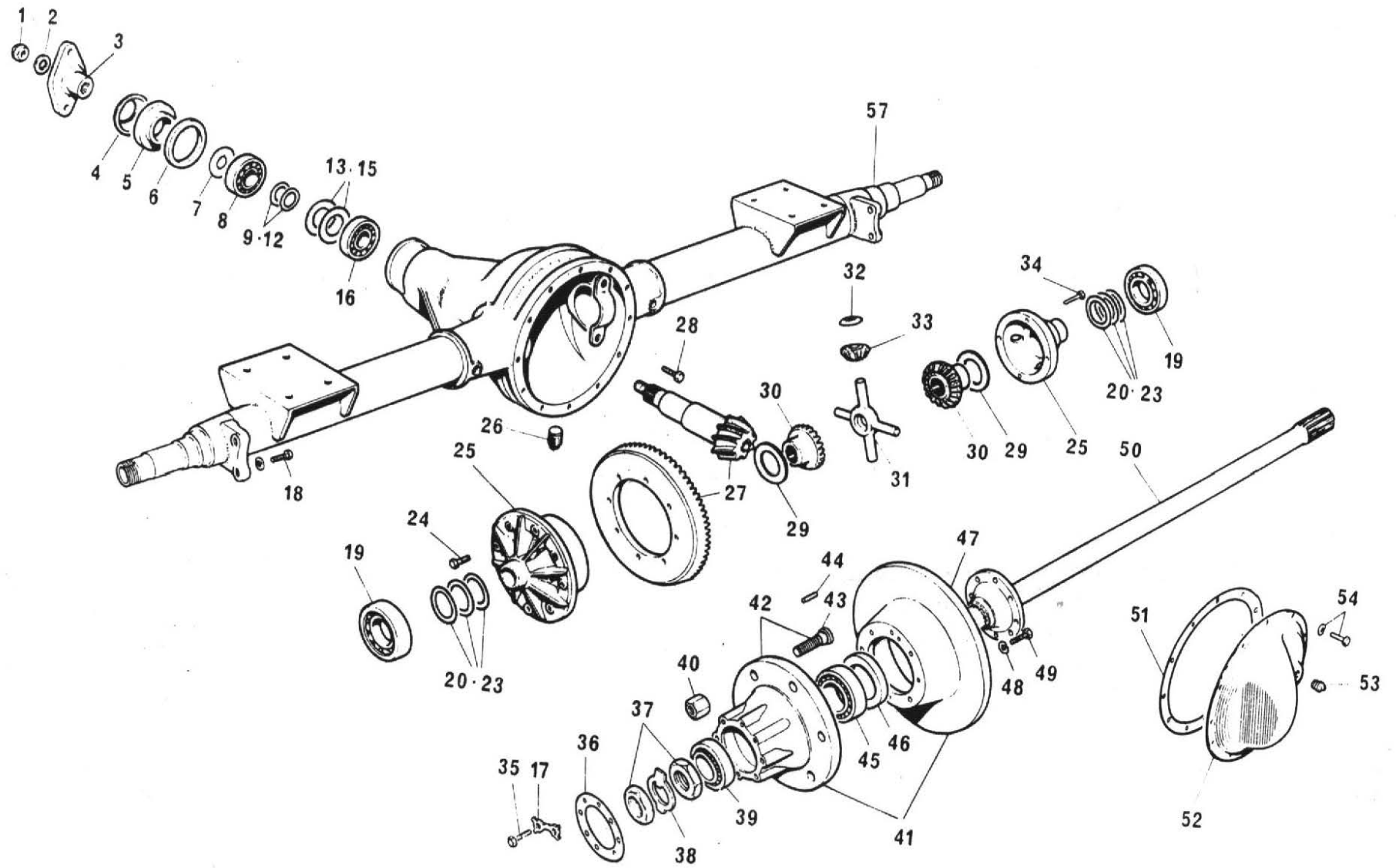

DRIVE AXLE 5HA 001-239

Item No.	Part No	Description	Qty. Req'd
1	12LN-NF9	Pinion Nut	1
2	12W-24	Pinion Nut Washer	1
3	5HA-102-8	Companion Flange Assembly Type 70 4.5/16" Ctrs.	1
4	2HA-021	Companion Flange Dust Shield	1
5	2HA-019	Pinion Oil Seal	1
6	2HA-020	Pinion Oil Seal Gasket	1
7	2HA-036	Pinion Oil Slinger	1
8	5HA-022	Pinion Bearing Outer	1
9	5HA-039	Pinion Adjusting Shim Outer (.003") as req'd	2
10	5HA-040	Pinion Adjusting Shim Outer (.005") as req'd	2
11	5HA-041	Pinion Adjusting Shim Outer (.010") as req'd	2
12	5HA-042	Pinion Adjusting Shim Outer (.030") as req'd	2
13	5HA-043	Pinion Adjusting Shim Inner (.003") as req'd	2
14	5HA-044	Pinion Adjusting Shim Inner (.005") as req'd	2
15	5HA-045	Pinion Adjusting Shim Inner (.010") as req'd	2
16	5HA-023	Pinion Bearing Inner	1
17	5HA-074-3	Axle Shaft Flange Lockstrap	8
18	7BNF-22-B	Brake Caliper Mounting Bolt	4
18A	7W-16	Caliper Mounting Packing Washer	4
18B	7W-14	Caliper Mounting Washer	4
18C	5HA-138	Caliper Adjusting Shim (.003")	A/R
18D	5HA-139	Caliper Adjusting Shim (.005")	A/R
18E	5HA-140	Caliper Adjusting Shim (.020")	A/R
18F	5HA-141	Caliper Adjusting Shim (.030")	A/R
19	5HA-024-1	Differential Bearing	2
20	5HA-046	Differential Bearing Shim (.003")	2
21	5HA-047	Differential Bearing Shim (.005")	2
22	5HA-048	Differential Bearing Shim (.010")	2
23	5HA-049	Differential Bearing Shim (.030")	2
24	5HA-075-2	Drive Gear Screw	12
25	5HA-006-1	Differential Case	1
	* 5HA-082-2	Differential Case Assembly	1
	* 5HA-082-11	Differential Case Assembly (From Serial No. N70/546)	1
26	HA-059	Drain & Filler Plugs	2
27	5HA-105-11	Drive Gear and Pinion Assembly including Items 1, 24 & 58	1
28	8BNC.36	Differential Bearing Cap Screw	4
28A	8LW-115	Differential Bearing Cap Lockwasher	4
29	5HA-038-1	Differential Case Side Gear Thrustwasher	2
30	5HA-007-4	Differential Side Gear	4
	5HA-007-3	Differential Side Gear (from Serial No. N70/546)	4
31	5HA-012-2	Differential Pinion Mate Shaft	1
32	5HA-037-1	Pinion Mate Thrustwasher	4
33	5HA-008-4	Pinion Mate	2
	5HA-008-3	Pinion Mate (from Serial No. N70/546)	2
34	5BNC2 BA	Differential Case Screw	8
34A	5HA-097	Differential Case Lockstrap	4
35	7BNC-20A	Axle Shaft Flange Driving Bolt	16
36	10HA-031	Axle Shaft Flange Gasket	2
37	32N-NF4	Wheel Bearing Locknut	4
38	8HA-091-2	Wheel Bearing Locking Washer	2
39	8HA-025-6	Wheel Bearing Outer	2
40	T.23	Wheel Nut	12
41	10HA-028-23	Hub and Disc Assembly	2
42	10HA-028-24	Wheel Hub with Studs	2

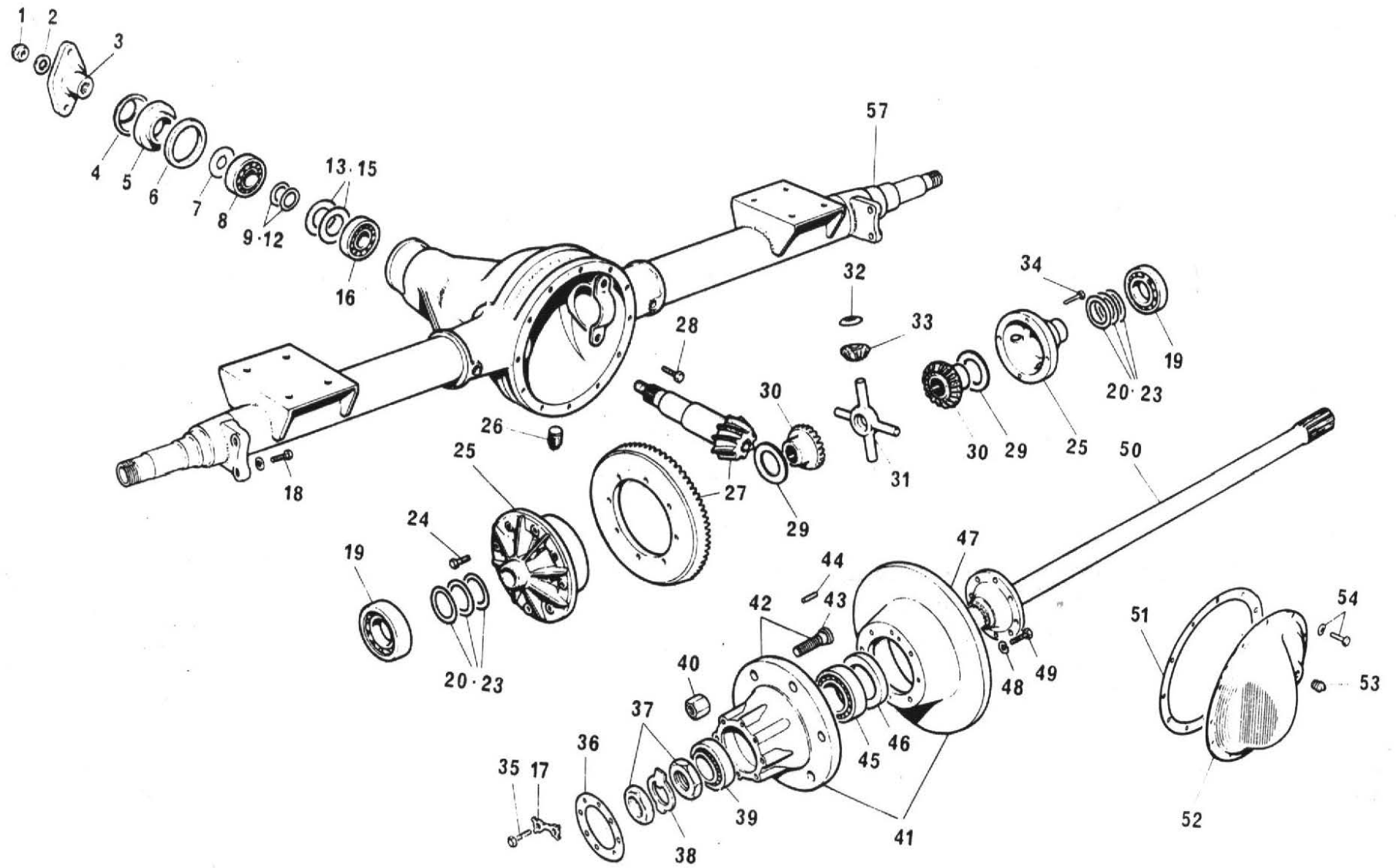

DRIVE AXLE Cont'd

<i>Item No.</i>	<i>Part No.</i>	<i>Description</i>	<i>Qty</i>
43	10HA-055-5	Wheel Stud	12
44	12RP-16	Brake Disc Dowel	4
45	8HA-025-5	Wheel Bearing Inner	2
46	5HA-032-6	Hub Oil Seal	2
47	10HA-136	Brake Disc	2
48	6LW-105	Brake Disc Retaining Washer	10
49	6BNF-21	Brake Disc Retaining Screw	10
50	5HA-005-75	Axle Shaft	2
51	5HA-026	Gear Carrier Cover Gasket	1
52	5HA-010-14	Gear Carrier Cover	1
53	HA-059	Filler Plug	1
54	6B-NC-10	Cover Screw and Washer	10
57	5HA-101-86	CARRIER TUBE	1

7819

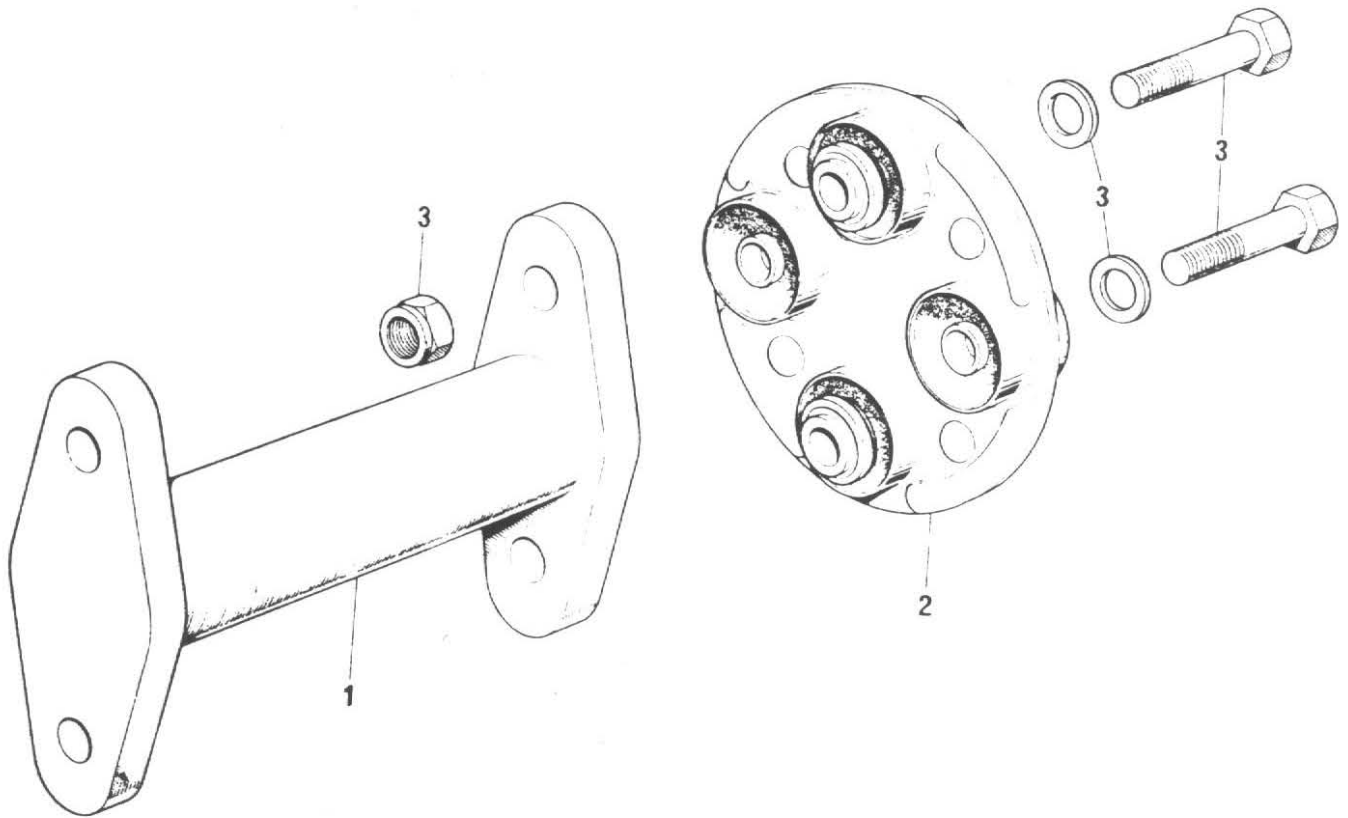

PROPSHAFT

Item No.	Part No.	Description	Qty.
1	5S10265	Prop shaft tube (1/2"/M12 bolts, 4.1/8" centers)	1
1A	5S10270	Prop shaft tube (9/16" bolts, 4. 5/16" centers)	1
2	2408	Coupling Type 65 4.1/8" centers	2
2A	10323A01	Coupling Type 70 4. 5/16" centers	2
3	2408A	Coupling bolt, washer and nut (M12)	8
3A	10203A	Coupling bolt, washer and nut (9/16")	8

2408A consists of bolt 8S05M, washers 267S07 and nyloc nuts 59S04

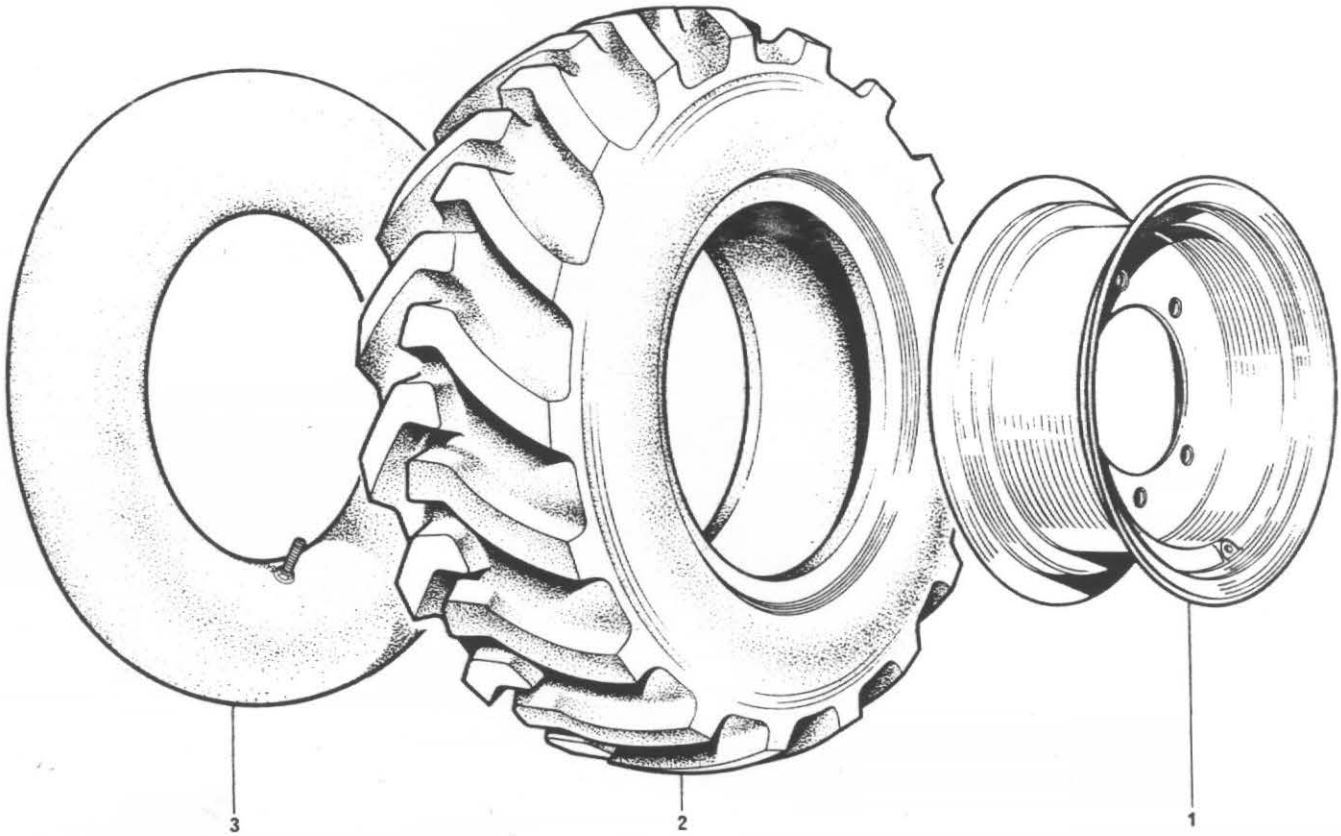

DRIVE WHEELS AND TYRES

Item No.	Part No.	Description	Qty.
	24S16	R/H Wheel Assembly	1
	24S15	L/H Wheel Assembly	1
1	30193A01	Wheel rim 9 x 18	2
2	20S01	Tyre 10.5 x 18-6 ply	2
3	23S04	Tube 10.5 x 18	2

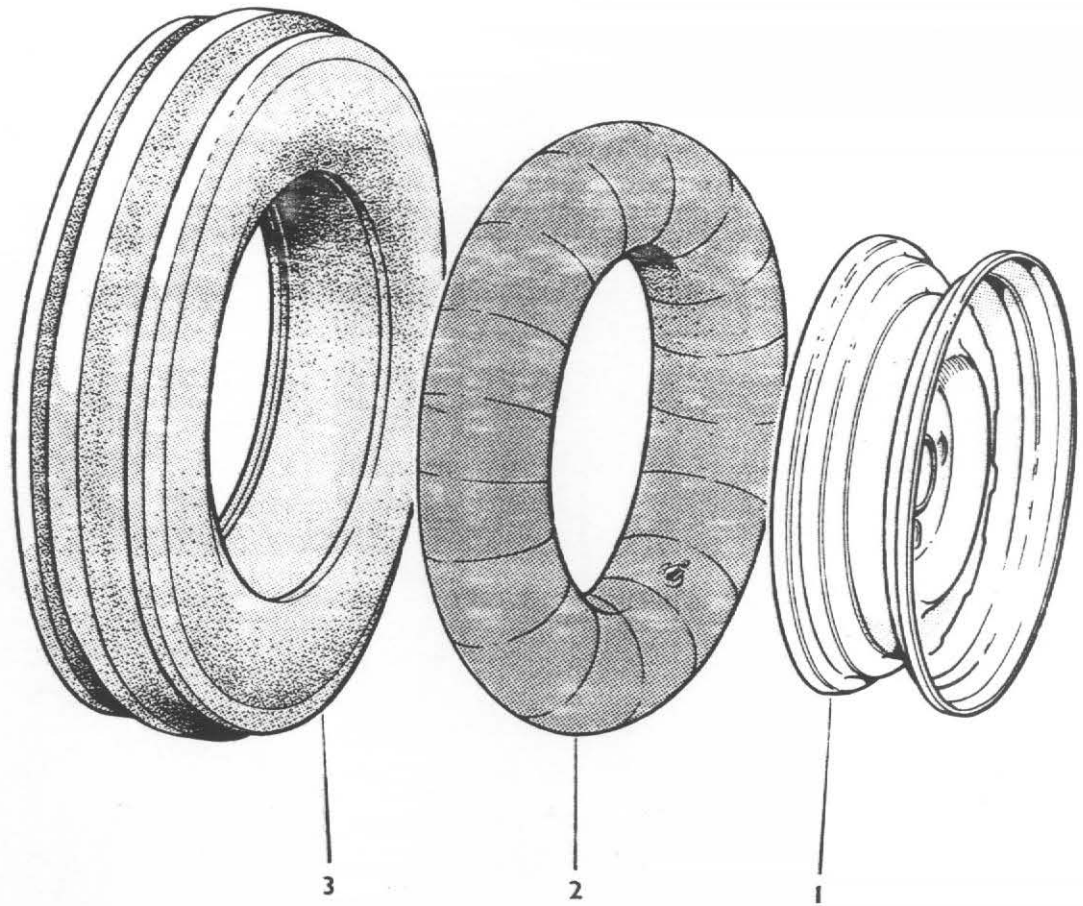

STEERING WHEELS AND TYRES

Item No.	Part No.	Description	Qty.
1	24S31	Steering wheel complete	2
2	30033A01	Wheel rim 4.00 x 16	2
3	23S02	Tube 6.00 x 16	2
	21S03	Tyre 6.00 x 16-4 ply	2

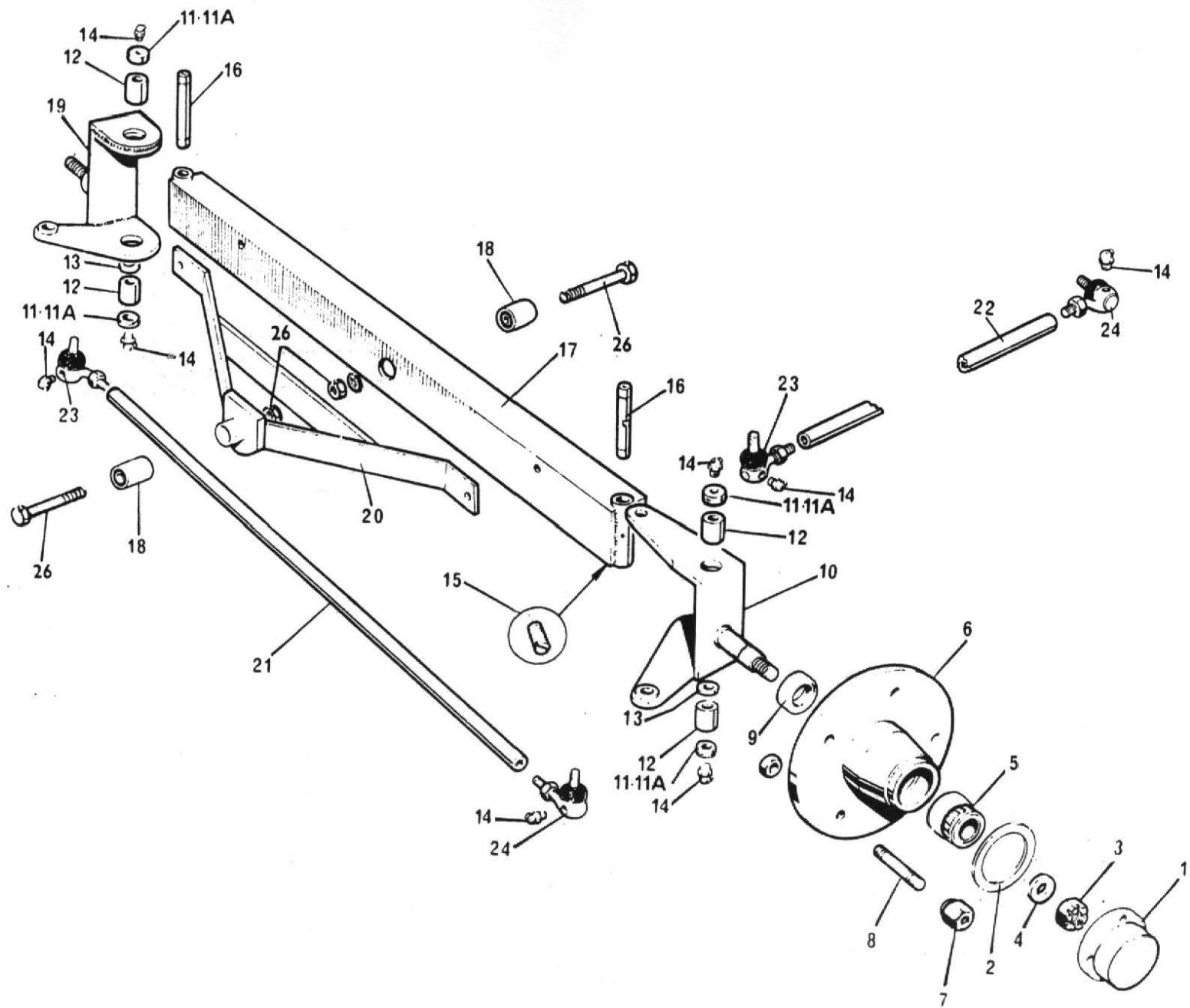

STEERING AXLE

<i>Item No.</i>	<i>Part No.</i>	<i>Description</i>	<i>No. Off</i>
1	R344	Hub Cap	2
2	R345	Gasket, Hub Cap	2
3	R305-A	Slotted Nut	2
4	4S149	Washer	2
5	K18690-K18620	Bearing, Hub	4
6	0190	Hub Assembly, including Items 1, 2, 5, 7, 82, 9	2
7	R340	Wheel Nut	10
8	0190-S	Wheel Stud	10
9	R343	Oil Seal, Hub Bearing	2
10	F505-OS	Stub Axle Assembly O/S	1
11	C180-A	Washer, King Pin (Felt)	4
11A	C180-B	Washer, King Pin (Steel)	4
12	C190	Bush, King Pin	4
13	C175	Thrust Washer	2
14	T90	Grease Nipple	8
15	C111-A	Screw, King Pin Retaining	2
16	R320	King Pin	2
17	F503	Steering Axle Beam	1
18	E2245	Bush, Steering Axle and Stabiliser	2
19	F505-NS	Stub Axle Assembly N/S	1
20	L262	Steering Axle Stabiliser	1
21	L308T	Track Rod	1
22	F513	Drag Link	1
23	C159/LH	Steering Ball Joint with Nut	2
24	C159/RH	Steering Ball Joint with Nut	2
26		Bolt, 7/8" UNF x 4" Long & Nut	2

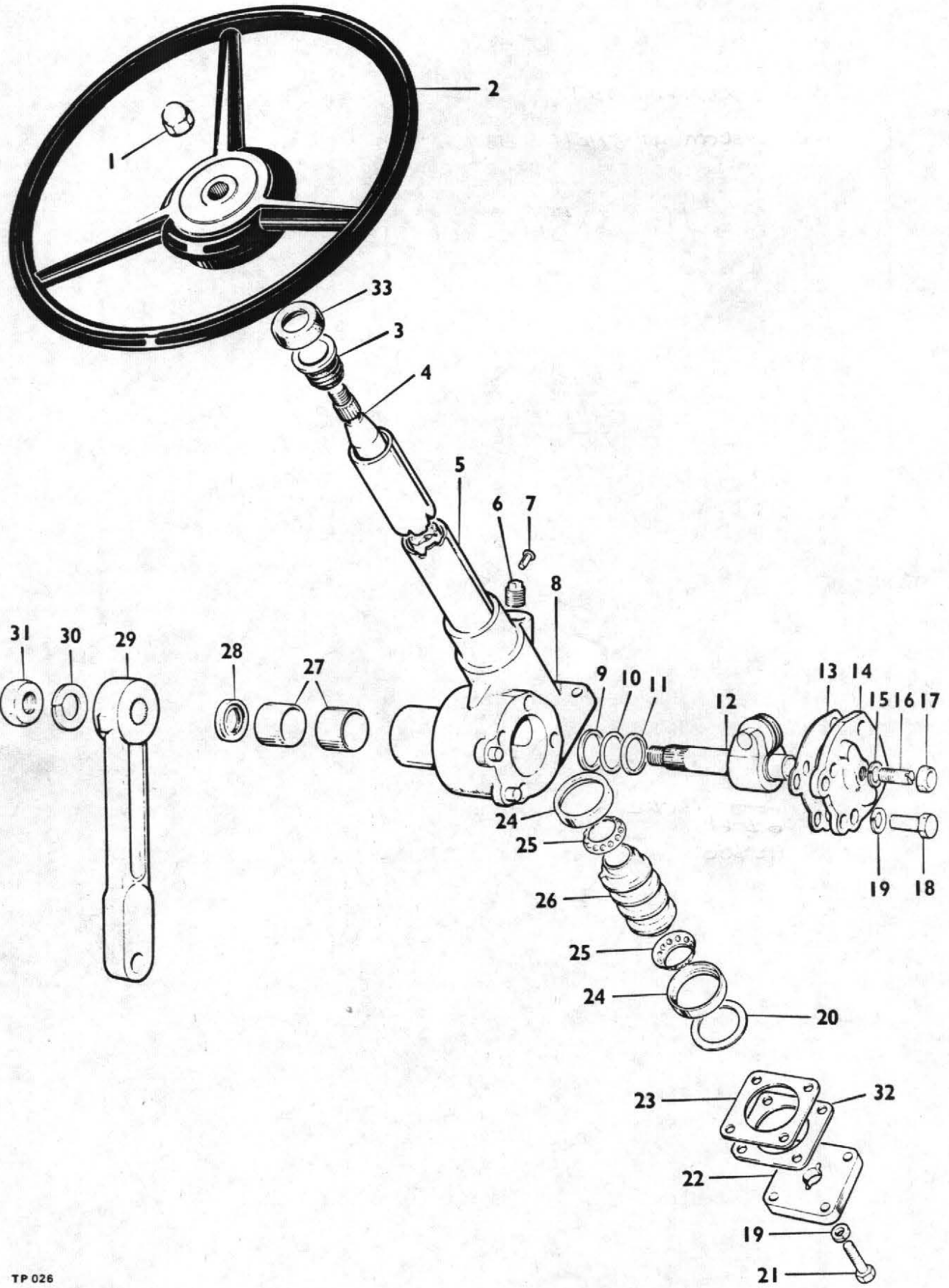

STEERING GEAR (CAM AND ROLLER TYPE)

Item No.	Part No.	Description	Qty.
	MGA 34849	Steering column assy. complete less items, 1,2 & 29	1
1	C 304	Steering wheel nut	1
2	347 K	Steering wheel	1
3	PA3904A	Column top bush	1
4	P5244/30"	Inner shaft	1
5	P3911/24"	Outer tube	1
6	S 9033	Oil plug	1
7	S 9166	Pin	1
8	PA4426	Steering box c/w item 14	1
9	P4151	Thrust washer	2
10	P 3308	Shim	A/R
11	P 4150	Thrust washer	2
12	PA5229/4¼"	Rocker shaft c/w roller	1
13	P3306A	Cover plate gasket	A/R
14	QA757	Cover plate and bush	1
15	S 999	Spring washer	1
16	P 4222	Adjuster screw	1
17	P 4221	Nut	1
18	S 9240	Setscrew	4
19	S 902	Spring washer	8
20	P3342	Washer	1
21	S 9300	Setscrew	4
22	P 3907	Bottom cap	1
23	P 3301/.005"	Shim	A/R
24	P 3341	Outer race	2
25	PA2733	Cage and balls	2
26	P 3340	Cam	1
27	P 3309	Bush	2
28	S 9242	Oil seal	1
29	M 29629	Drop arm	1
30	S 955	Spring washer	1
31	S 9332	Nut	1
32	P 3301G	Bottom cap liner	2
33	M33418	Inner column shroud	1

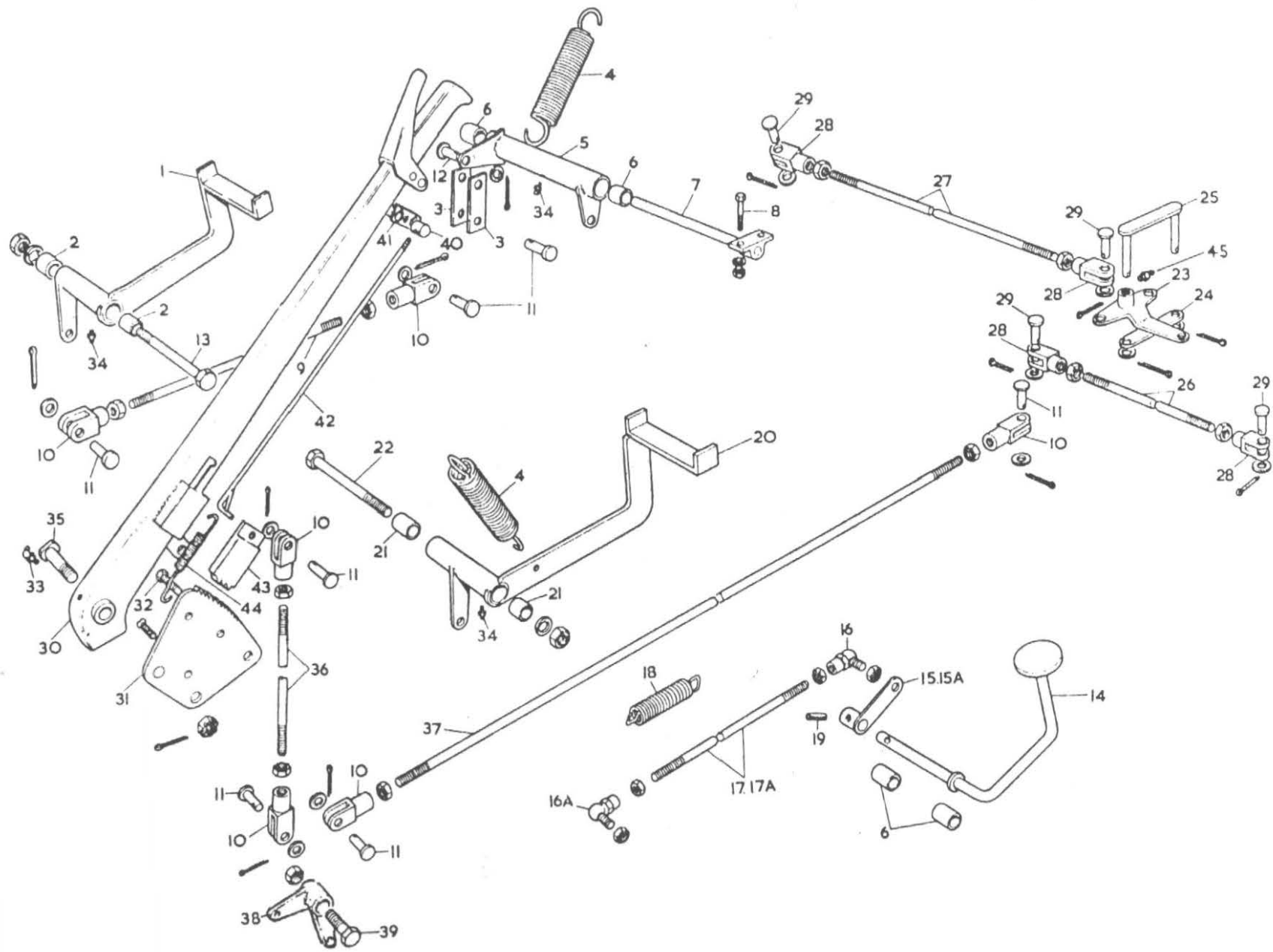

CLUTCH, HANDBRAKE & FOOTBRAKE ASSEMBLIES

Item No.	Part No.	Description	No. Off
1	F521	Pedal, Clutch	1
2	WB.1010	Bush, Clutch Pedal	2
3	F537	Link, Clutch Lever	2
4	C173-B	Spring, Return (Clutch and Footbrake Pedal)	2
5	F519	Lever, Clutch Transfer	1
6	WB0808	Bush, Transfer Lever (Clutch and Accelerator)	2
7	F519A	Rod, Clutch Transfer Lever	1
8		Nut and Bolt, $\frac{3}{8}$ "BSF x $1\frac{1}{2}$ " Long	1
9	F525	Rod, Clutch Adjusting $14\frac{1}{2}$ " x $\frac{3}{8}$ "BSF	1
10	C174 A	Clevis	6
11	C174 X	Clevis Pin	7
12	5ST-101	Clevis Pin	1
13		Nut and Bolt, $\frac{5}{8}$ "BSF x $4\frac{1}{2}$ " Long	1
14	C137	Pedal, Accelerator	1
15	F522	Lever, Accelerator (Petter)	1
15A	C 308	Lever, Accelerator (Lister)	1
16	C160-B	Ball End, Accelerator Rod	1
16A	C160-B	Ball End, Accelerator Rod	1
17	5ST-22	Rod, Accelerator (Petter)	1
17A	4S 166	Rod, Accelerator (Lister)	1
18	C173-D	Spring, Return (Accelerator Rod)	1
19	C251-1	Pin, Tension	1
20	4S.102	Pedal, Footbrake	1
21	WB1212	Bush, Footbrake Pedal	2
22		Nut and Bolt $\frac{1}{2}$ " BSF x 8" Long	1
23	C272	Arm, Compensator Lever	1
24	C189-A	Link, Compensator	1
25	C271	Compensator Link Assembly	1
26	L278A	Rod, Brake	1
27	4S.107	Rod, Handbrake	1
28	C174-C	Forkend	2
29	C174-Y	Clevis Pin	2
30	F517	Handbrake Lever Complete	1
31	F517A	Quadrant, Handbrake Lever	1
32		Bolt, $\frac{5}{16}$ " BSF x 1" Long	2
33	T90	Nipple, Grease (90°)	1
34	TST	Nipple, Grease (Straight)	3
35	F517B	Bolt, Handbrake Carrier	1
36	T 21C	Rod, Lever Connecting $\frac{3}{8}$ BSF x 9" long	1
37	4S.108	Rod, Handbrake	1
38	LT292	Lever, Handbrake Transfer	1
39		Nut and Bolt, $\frac{5}{8}$ "BSF x $3\frac{1}{2}$ " Long	1
40	000022/A	Pin, Latch Pivot Arm	1
41	14425A	Arm, Latch Pivot	1
42	10291C	Rod, Handbrake Rod	1
43	6266A	Pawl, Handbrake Pawl	1
44	12873-A	Spring, Handbrake	1
45	5ST 100	Grease Nipple	1

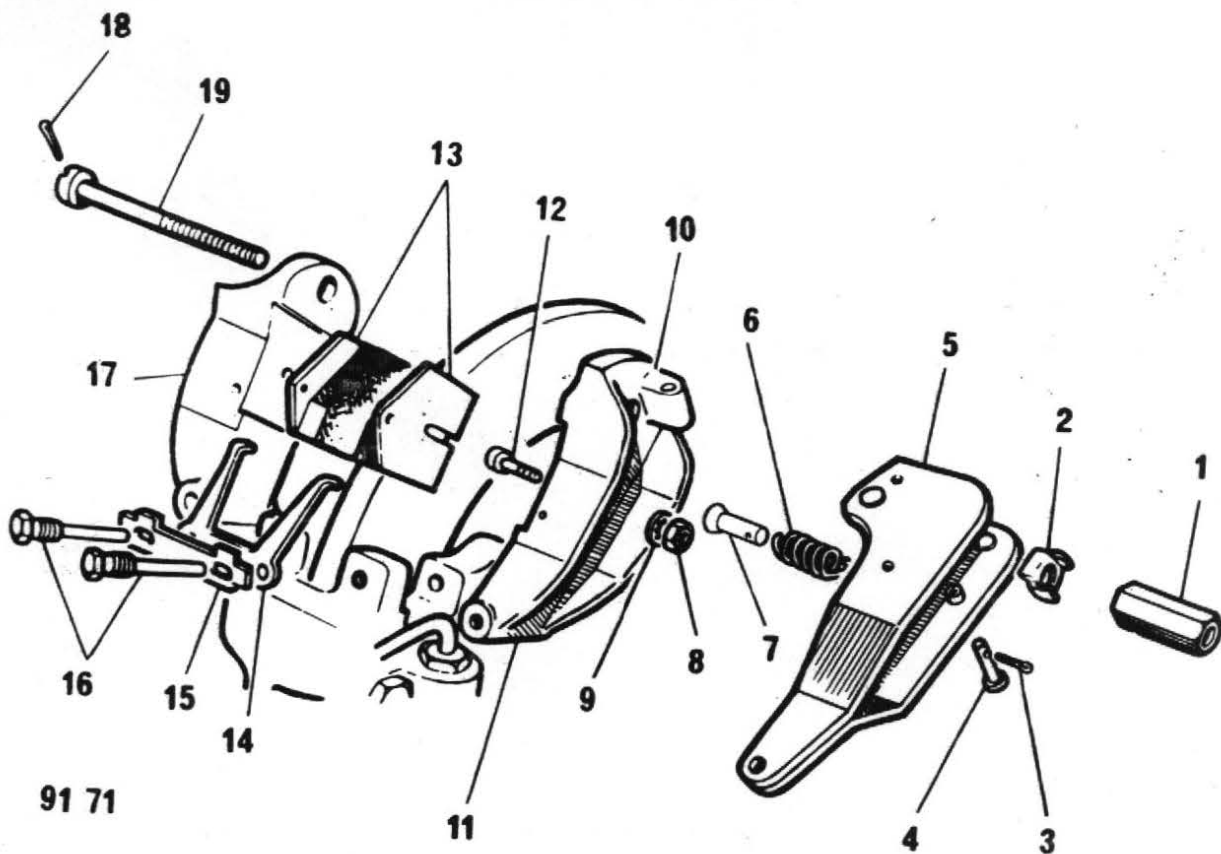

91 71

HANDBRAKE ASSEMBLY

Item No.	Part No.	Description	No. Off
1	CB20258	Nut, Adjustment	2
2	VBO8307	Spring, Friction	2
3	VBO6135D	Split Pin	2
4	VBO8315	Pin, Hinge	2
5	CB20526	Lever Assembly	2
6	VBO7329	Spring, Return	2
7	VBO7330	Spring Anchor	2
8	VBO6050	Nut 2BA	4
9	VBO6101F	Washer	4
10	VBO8308	Pivot Seat	2
11	CB60249/8308	Carrier Pad Assembly/Inner c/w Pivot Seat	2
12	VBC4124	Bolt	4
13	CB20311/Y	Friction Pad (4 per set)	1 set
14	VBM4635/1	Plate, Retraction	2
15	VBO4226	Washer, Tab	2
16	VBO4190	Bolt	4
17	VBM4573	Carrier Pad (Outer)	2
18	VBO6158/G	Split Pin	2
19	CB20289	Bolt	2
	CB90256	H/B Right Complete	1
	CB90257	H/B Left Complete	1

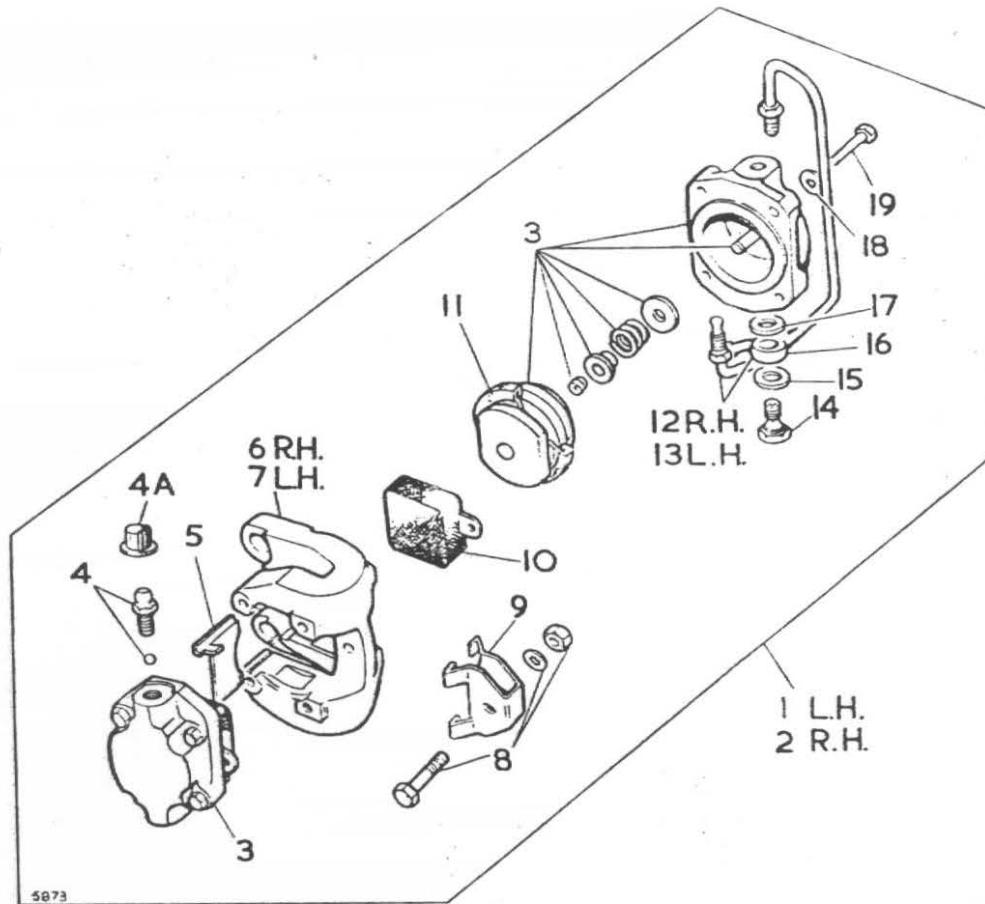

CALIPER ASSEMBLY

Item No.	Part No.	Description	No. Off
1	CB90262	Caliper Assy. Complete (LH)	1
2	CB90263	Caliper Assy. Complete (RH)	1
3	VB05505	Piston & Cylinder Assy.	4
4	VB08378	Bleed Screw & Ball Assy.	2
4A	CB0849	Dust Cover (Bleedscrew)	2
5	VB05133	Plate, Support	4
6	CB60253	Body, Caliper (RH)	1
7	CB60252	Body, Caliper (LH)	1
8	VB08491	Nut, Bolt & Washer (Keep Plate)	2
9	VB05123	Keep Plate	2
10	CB20554Y	Friction Pad Complete (Set of 4)	1 set
11	VB08210A	Seal Kit (Dust & Piston)	4
12	VB03927	Bridge Pipe Assy. (RH)	1
13	VB03926	Bridge Pipe Assy. (LH)	1
14	VB06008	Banjo Bolt $\frac{3}{8}$ " UNF	2
15	VB06113	Washer, Copper	2
16	VB06212	Banjo $\frac{3}{8}$ " UNF	2
17	VB06112	Washer, Copper	2
18	VB06101L	Washer, Shakeproof	16
19	VB05100	Bolt, Retaining (Cylinder)	16

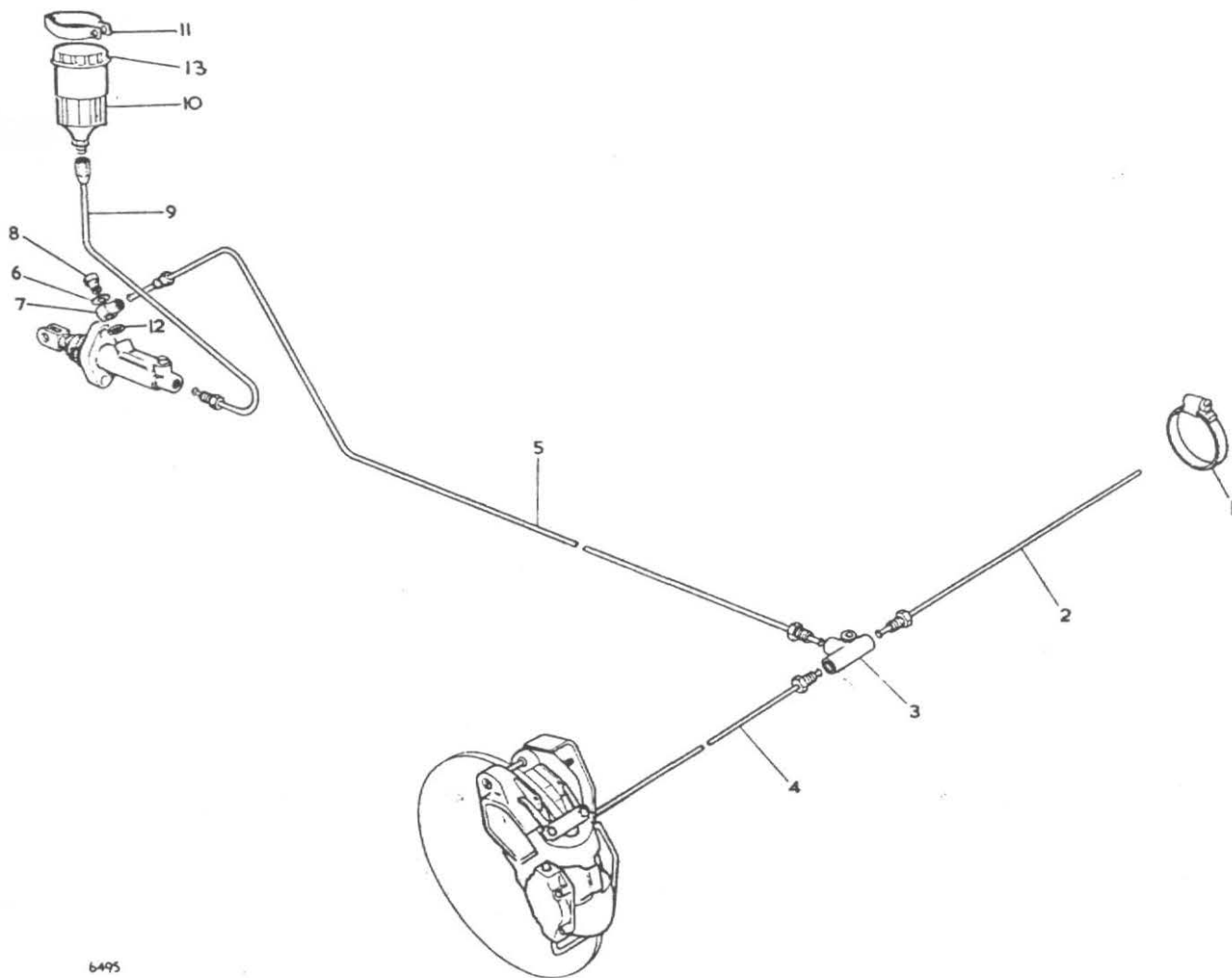

6495

HYDRAULIC BRAKE SYSTEM

1	4S 133	Hose Clip	1
2	3508610W	Pipe (43")	1
3	64474341	Tee Piece	1
4	64476097	Pipe (18 $\frac{1}{2}$ ")	1
5	64474263	Pipe (53")	1
6	378700	Washer	1
7	64474287	Banjo	1
8	376102W	Banjo Bolt	1
9	3424240W	Pipe (21")	1
10	64046158	Header Tank	1
11	64477544	Clip	1
12	378703	Washer	1
13	64474602	Tank Cap	1

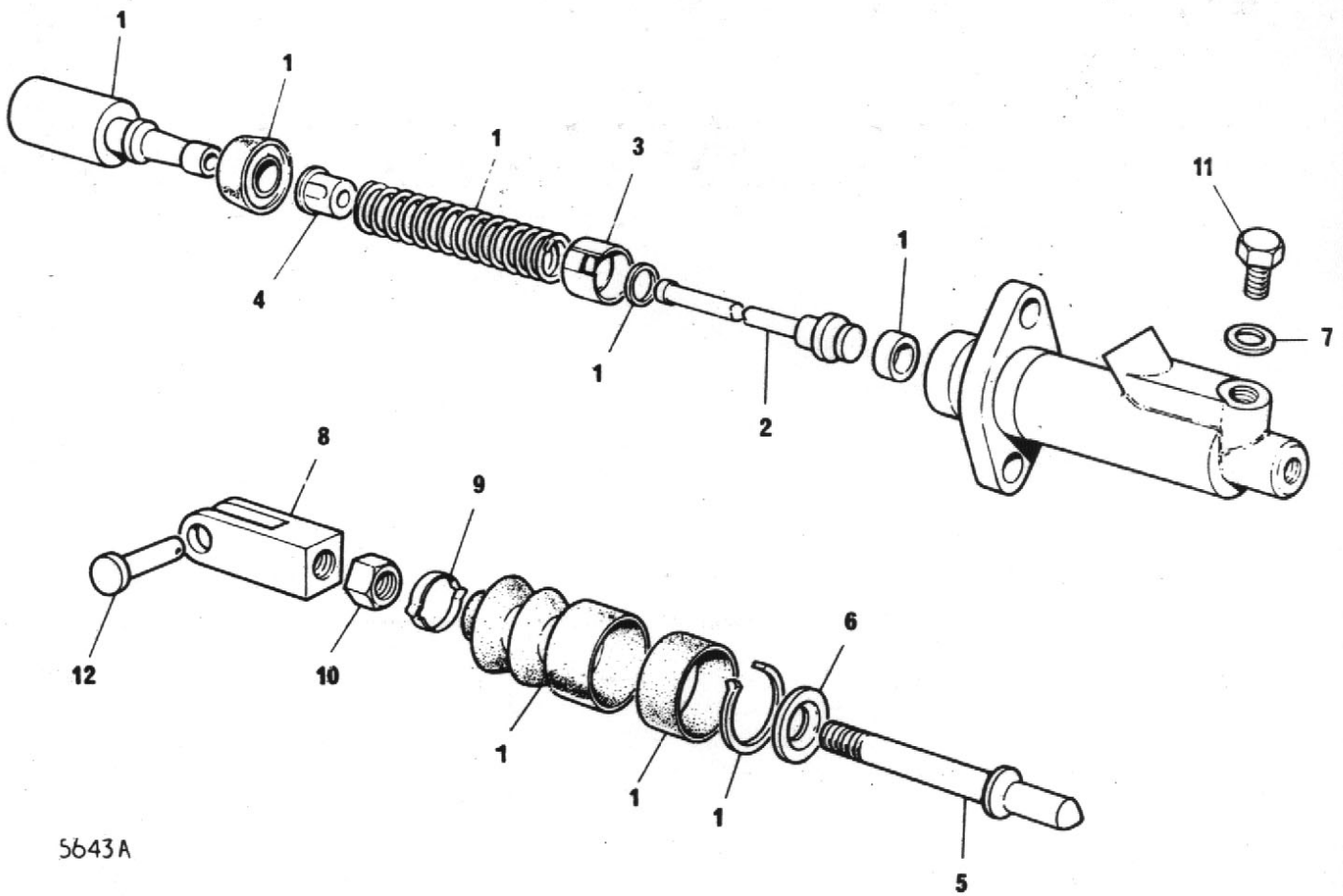

5643A

MASTER CYLINDER

Item No.	Part No.	Description	No. Off
	64067970	Master Cylinder Complete	1
1	SP 1996-2	Seal Kit	1
2	378641	Valve Stem	1
3	318001	Valve Spacer	1
4	64673391	Valve Spring Retainer	1
5	351257W	Push Rod	1
6	378242	Retaining Washer	1
7	378700	Washer	1
8	64671286	Clevis	1
9	378312	Dust Cover Retainer	1
10	64100052	Lock Nut	1
11	64110348	Plug	1
12	C 174 Y	Clevis Pin	1

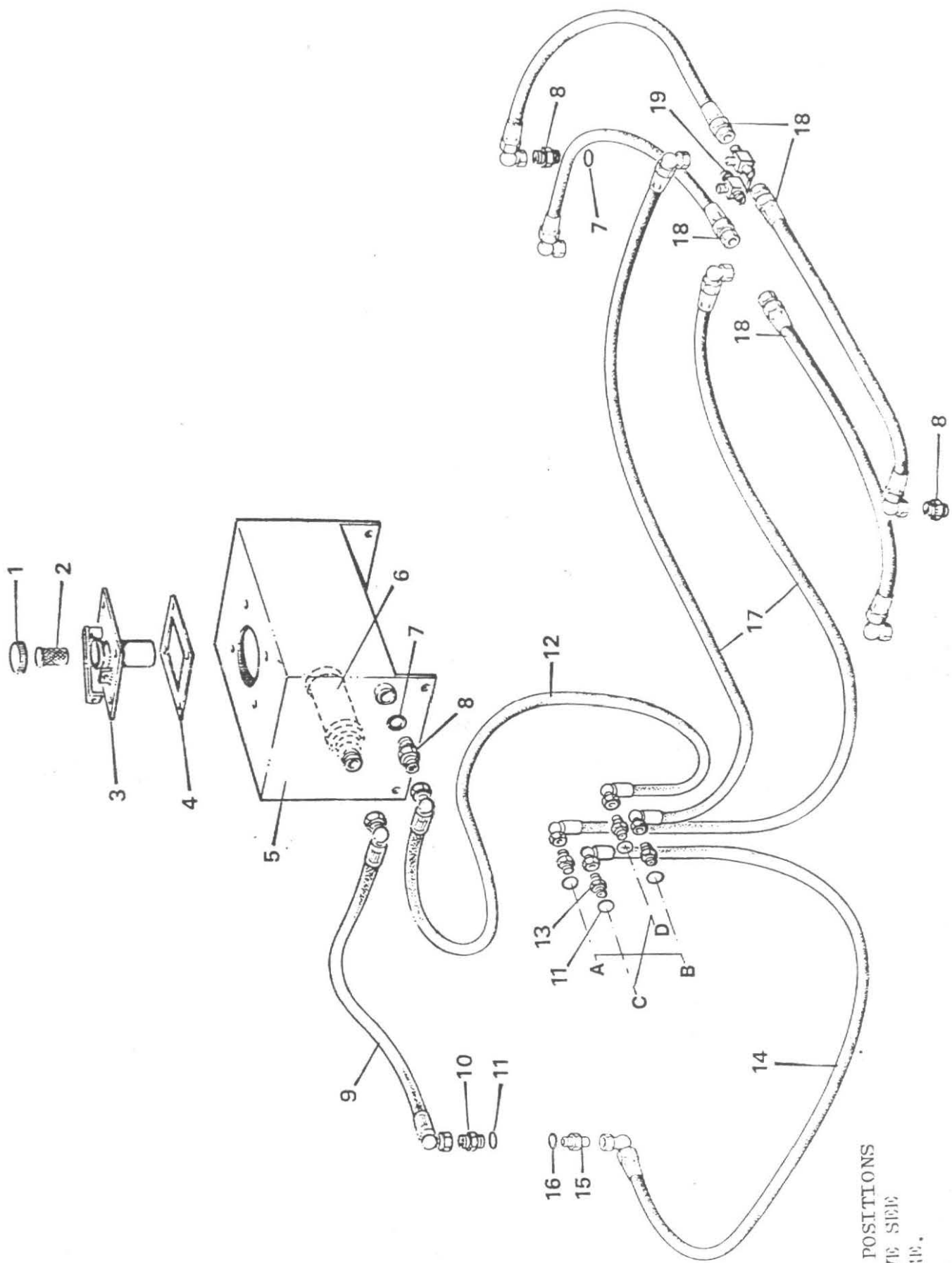

NOTE:-
 FOR HOSE POSITIONS
 INTO VALVE SEE
 VALVE PAGE.

HYDRAULIC PIPES AND FITTINGS

Item No.	Part No.	Description	Qty
1	P 2578	Hydraulic tank cap	1
2	P 1145	Strainer	1
3	4-35-187	Cover Plate Assembly	1
4	T 18 B	Gasket	1
5	2ST 118	Hydraulic tank	1
6	UC 1457	Filter	1
7	T 14 I	Sealing washer	3
8	T 14 J	Adaptor $\frac{3}{8}$ " BSP x $\frac{3}{8}$ " BSP	3
9	2ST 72E	Hose (Tank to Pump) (Petter)	1
	5SH 60	Hose (Tank to Pump) (Lister)	1
10	2ST 72F	Adaptor $\frac{3}{4}$ " J.I.C. x $\frac{1}{2}$ " BSP	1
11	2ST 72J	'O' Ring	5
12	4SH 65	Hose (Valve to Tank)	1
13	4-35-40K	Adaptor $\frac{3}{4}$ " J.I.C. x $\frac{3}{8}$ " BSP	4
14	4SH 56	Hose (Pump to Valve) (Petter)	1
	2ST 72D	Hose (Pump to Valve) (Lister)	1
15	2ST 72G	Adaptor 9/16" J.I.C. x $\frac{3}{8}$ " BSP	1
16	2ST 72K	'O' Ring	1
17	4SH 54	Hose (Valve to Tee)	2
18	3SH 63	Hose	4
19	3SH 66	Six way Tee piece	1
20	4SH 68	Hydraulic Control Valve Mtg.Brkt. (Not illustrated)	1

When an electric start Petter engine is fitted the following item changes occur:-

Item No.	New Part No.	Description	Qty.
9	2ST97A	Hose (tank to pump)	1
14	4-35-108H	Hose (pump to valve)	1

US304

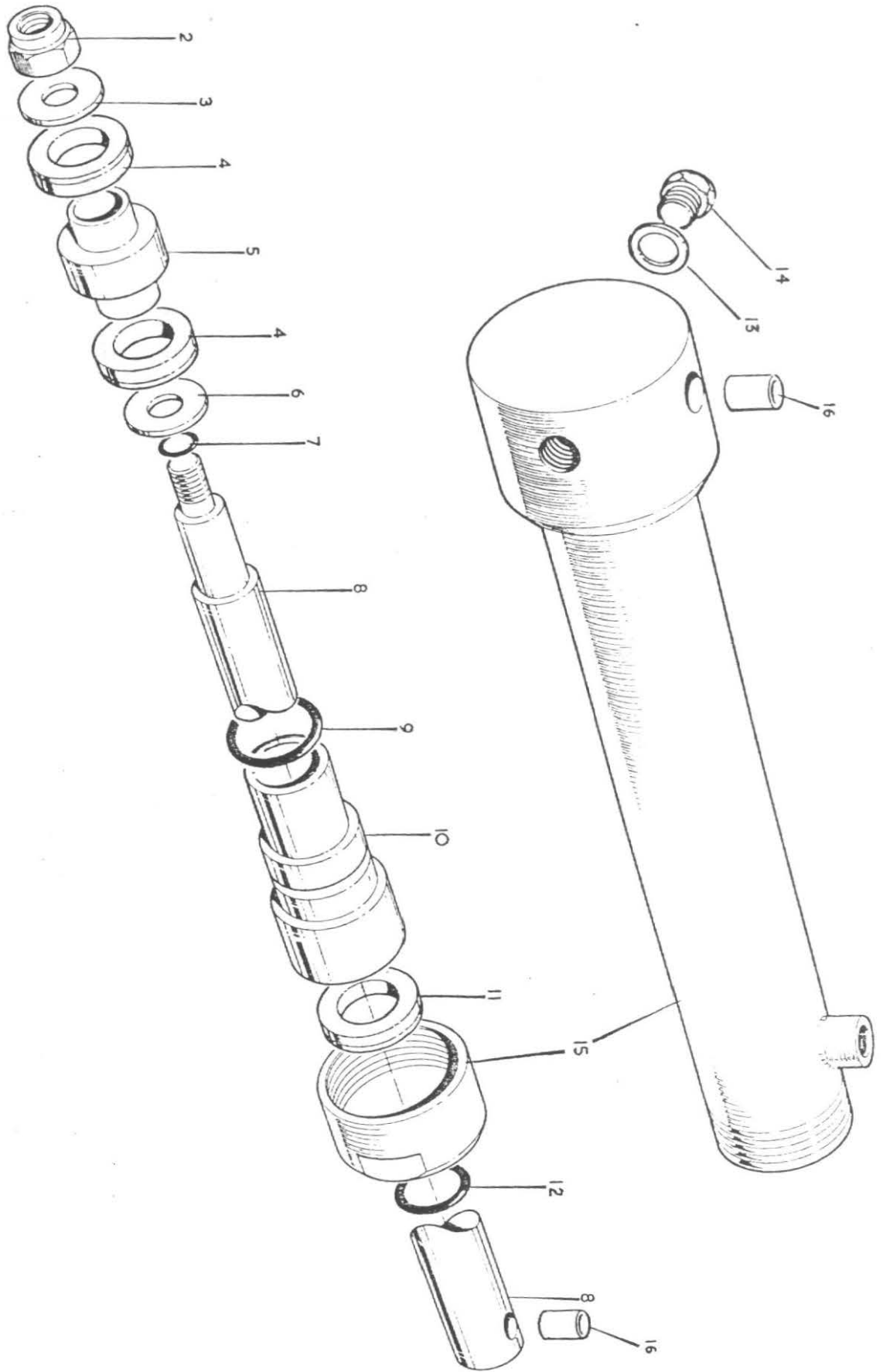

HYDRAULIC CYLINDER

Item No.	Part No.	Description	Qty
1	30287.A01	Cylinder (complete)	2
2		Locknut $\frac{5}{8}$ " BSF	1
3	LS.104-10	Backing washer	1
4	R.7784-S	Piston Seal	2
5	TD.2910	Piston Head	1
6	LS.104-11	Backing washer	1
7	BS.117	Piston 'O' Ring	1
8	TD.1873	Piston Rod	1
9	BS.224	Sleeve 'O' Ring	1
10	TD.2913	Sleeve	1
11	R.4041-S	Sleeve Seal	1
12	PP.58-13	Wiper	1
13		Copper washer $\frac{3}{8}$ " BSP	1
14	TD.1448-C	Plug	1
15	TD.4254	Cylinder (complete with tube cap)	1
16	10DU14	Glacier Bush	3
17	3SH 81	Seal Kit comprising items 4, 7, 9, 11 and 12	A/R

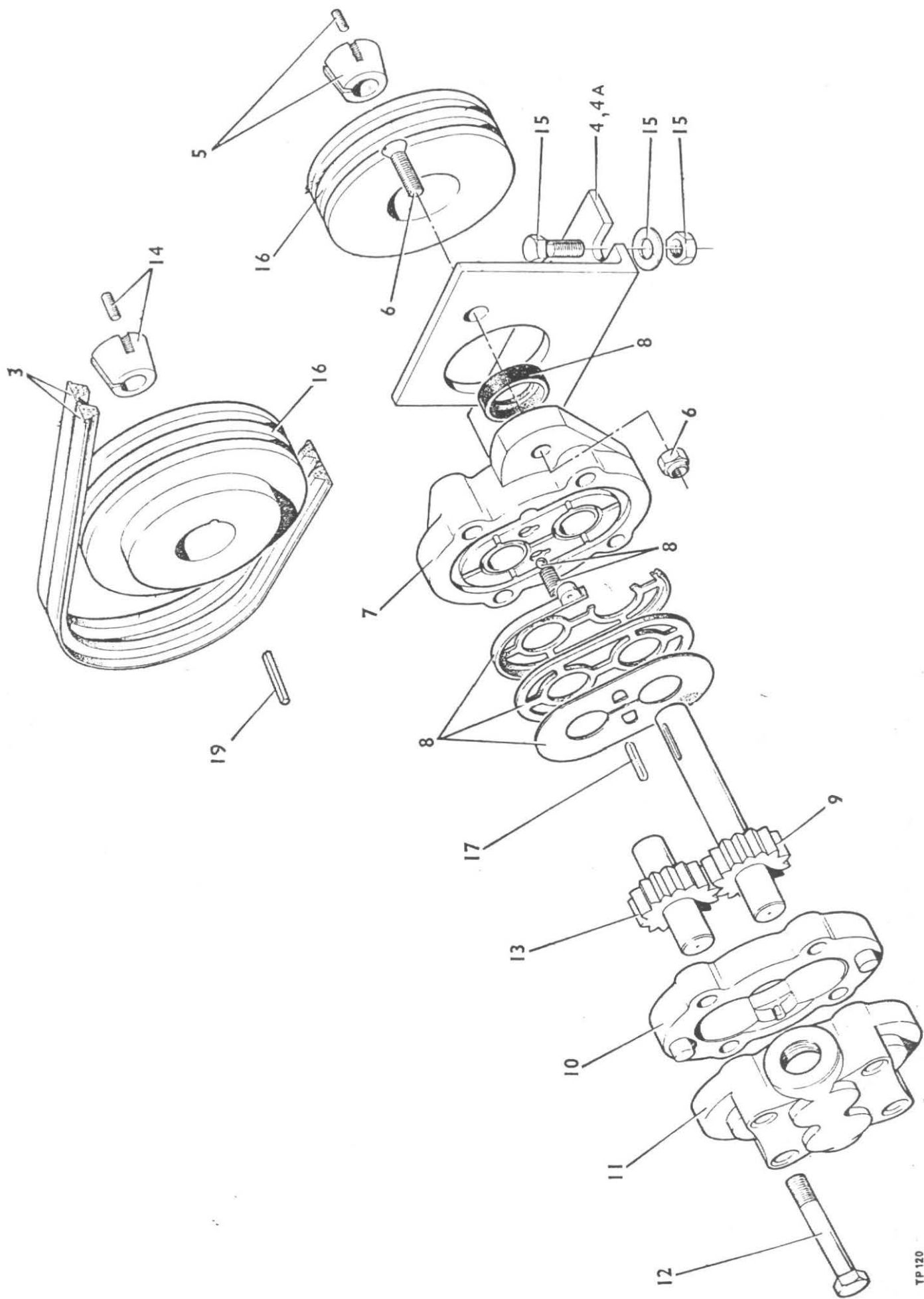

HYDRAULIC PUMP & DRIVE

Item No.	Part No.	Description	Qty
1	H 20210-0 AEA	Pump Assembly (PETTER)	
2	H 20210-1 AEA	Pump Assembly (LISTER)	
3	2 ST 121	Wedge Belt	2
4	2 ST 119	Pump Mounting Bracket (LISTER)	1
4A	4 SH 62	Pump Mounting Bracket (PETTER)	
		Not Illustrated	1
5	2 ST 124	Taper Lock Bush	1
6		Countersunk Bolt $\frac{3}{8}$ " UNF x $1\frac{1}{4}$ " long & Nut	2
7	20200-20	Front Plate Assembly	1
8	20200-34	Seal Repair Kit	1
9	20210-7	Drive Gear Assembly	1
10	20210-13	Body & Dowel Assembly	1
11	20200-36	Back Plate Assembly	1
12	16032-522	Hex Screw	4
13	20210-8	Idler Gear Assembly	1
14	2 ST 123	Taper Lock Bush	1
15		Bolt $\frac{3}{8}$ " UNF x $1\frac{1}{4}$ " long, Washer & Nut	2
16	2ST 122	Pulley	2
17	20200-25	Key	1
18	4 SH 63	Pump Mounting Bracket Plate (PETTER)	
		Not Illustrated	1
19	ASE 159	Key (Crankshaft	1

When an electric start Petter engine is fitted the following item changes occur:-

Item No.	New Part No.	Description	Qty.
1	10880A02	Hydraulic Pump	1
4	3SH79	Bracket - H. Pump Mounting	1
18	3SH80	Plate - H. Pump Mounting (not illustrated)	1

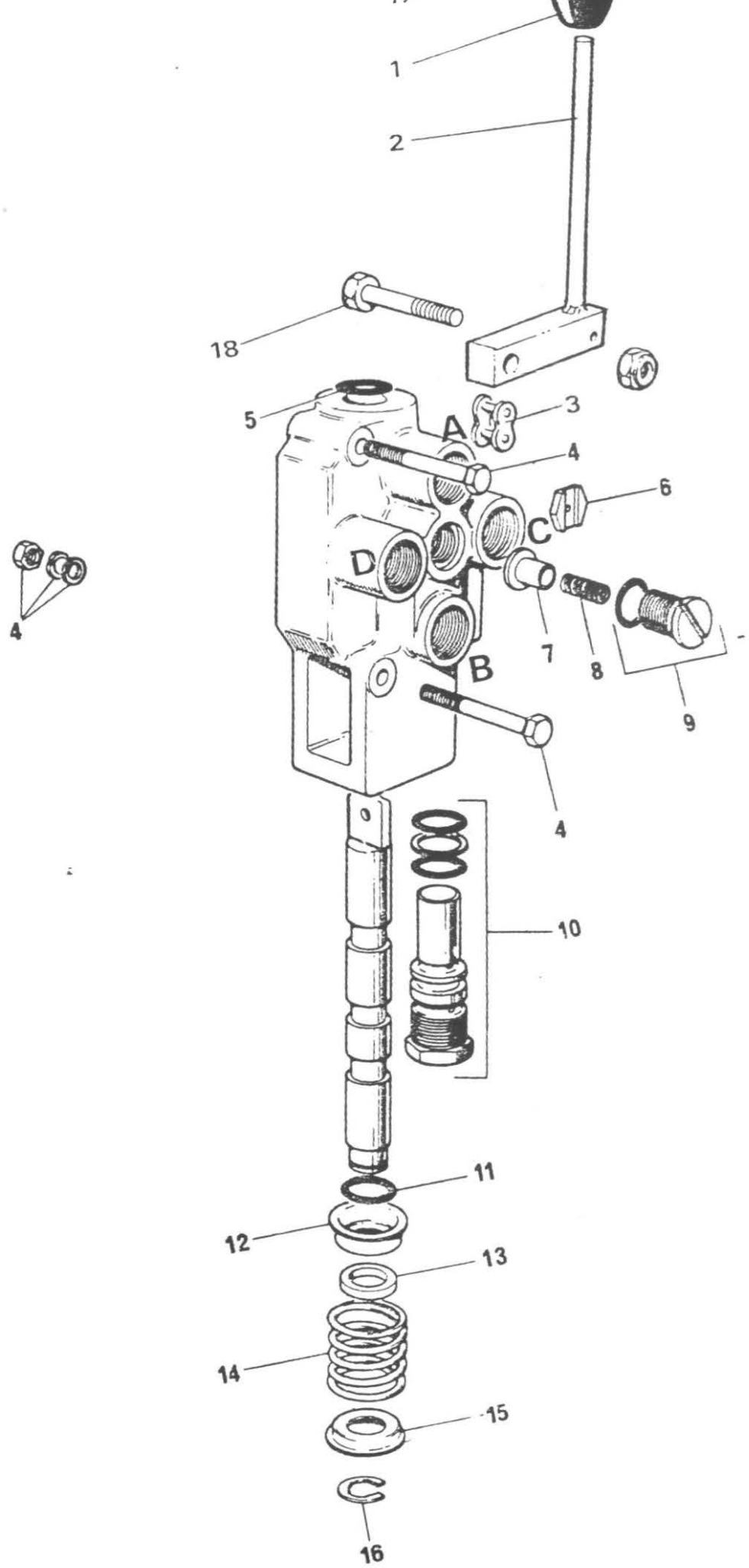

HYDRAULIC CONTROL VALVE

Item No.	Part No.	Description	No. Off
	3SH 88	Control Valve Assembly	
	300-024-AAD	Hydraulic Control Valve	1
1	10211 A01	Control Knob	1
2	4SH 69	Valve Control Lever	1
3	4-60-178	Connection Link	1
4		Bolt 5/16" UNF x 2 $\frac{1}{2}$ " Long, Nut and Washers	2
5	100-147-063	'O' Ring	1
6	16097-3-35	Orifice Plate	1
7	30501-12	Lift Check Plunger	1
8	30501-13	Lift Check Spring	1
9	30501-17	Lift Check Plug Assembly	1
10	30218-L9	Relief Valve Assembly	1
11	100-146-012	'O' Ring 3/32" dia. x $\frac{5}{8}$ " i/d	1
12	30501-10	Deep Washer	1
13	16048-31	Washer, Spacer	1
14	30501-39	Spool Spring	1
15	15546-6	Shallow Washer	1
16	16124-50	Clip Ring $\frac{1}{2}$ " Shaft	1
17	10284 A01	Hyd. Valve Control Knob label	1
18		Bolt M10 x 50 mm long & nut	1

WIRING DIAGRAM (ELECTRICAL SYSTEM)

PETER

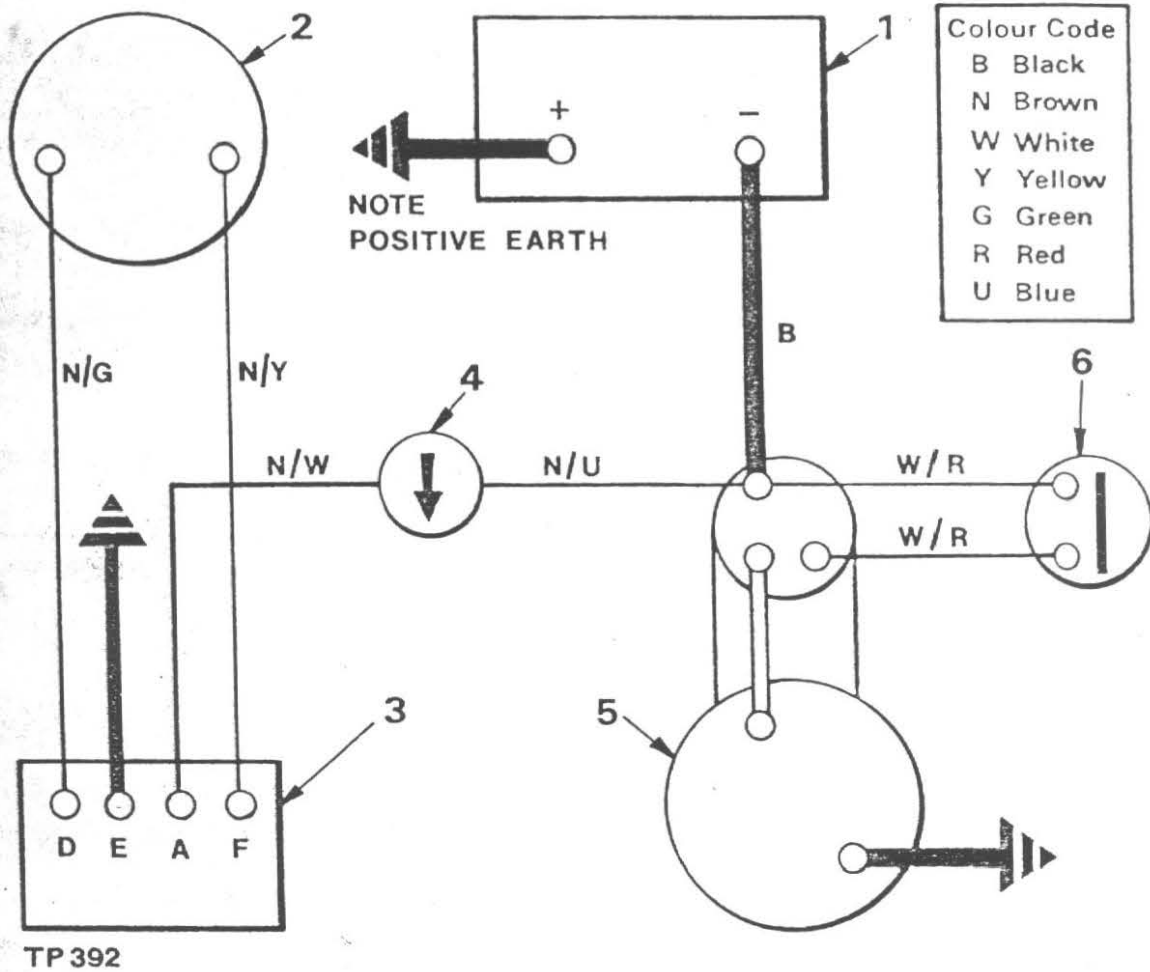

ELECTRICAL SYSTEM (PETER)

(Not Illustrated)

Item No.	Part No.	Description	Qty.
1	109S.01	Battery	1
	109S.03	Battery (Alternative)	1
	109S.05	Battery (Alternative)	1
2	10610A01	Dynamo(Supplied	1
3	10611A02	Regulator(By	1
4	10612A02	Ammeter(Makers	1
5	10613A01	Starter c/w Solenoid(With	1
6	10614A01	Starter Switch(Engine	1
7	10559A01	Battery Clamp Assy.	1
8	40S.A17	Rod ½" UNF.	2
9	9S.01	Nut - Full ½" UNF	8
10	10S.12	Washer - Bright ½"	4
11	10742A05	Battery Cover	1
12	177S.03	Wing Nuts	2

DECIMAL, FRACTIONAL AND METRIC EQUIVALENTS

Inches		Milli- metres	Inches		Milli- metres
Fractions	Decimals		Fractions	Decimals	
1/64	0.015625	0.397	33/64	0.515625	13.097
1/32	0.03125	0.794	17/32	0.53125	13.494
3/64	0.046875	1.191	35/64	0.546875	13.891
1/16	0.0625	1.588	9/16	0.5625	14.288
5/64	0.078125	1.984	37/64	0.578125	14.684
3/32	0.09375	2.381	19/32	0.59375	15.081
7/64	0.109375	2.778	39/64	0.609375	15.478
1/8	0.125	3.175	5/8	0.625	15.875
9/64	0.140625	3.572	41/64	0.640625	16.272
5/32	0.15625	3.969	21/32	0.65625	16.669
11/64	0.171875	4.366	43/64	0.671875	17.066
3/16	0.1875	4.763	11/16	0.6875	17.463
13/64	0.203125	5.159	45/64	0.703125	17.859
7/32	0.21875	5.556	23/32	0.71875	18.256
15/64	0.234375	5.953	47/64	0.734375	18.653
1/4	0.250	6.350	3/4	0.750	19.050
17/64	0.265625	6.747	49/64	0.765625	19.447
9/32	0.28125	7.144	25/32	0.78125	19.844
19/64	0.296875	7.541	51/64	0.796875	20.241
5/16	0.3125	7.938	13/16	0.8125	20.638
21/64	0.328125	8.334	53/64	0.828125	21.034
11/32	0.34375	8.731	27/32	0.84375	21.431
23/64	0.359375	9.128	55/64	0.859375	21.828
3/8	0.375	9.525	7/8	0.875	22.225
25/64	0.390625	9.922	57/64	0.890625	22.622
13/32	0.40625	10.319	29/32	0.90625	23.019
27/64	0.421875	10.716	59/64	0.921875	23.416
7/16	0.4375	11.113	15/16	0.9375	23.813
29/64	0.453125	11.509	61/64	0.953125	24.209
15/32	0.46875	11.906	31/32	0.96875	24.606
31/64	0.484375	12.303	63/64	0.984375	25.003
1/2	0.500	12.700	1	1.000	25.400

INCHES INTO MILLIMETRES

Inches	0	1	2	3	4	5	6	7	8	9
0	0	25.40	50.80	76.20	101.60	127.00	152.40	177.80	203.20	228.60
10	254.00	279.40	304.80	330.20	355.60	381.00	406.40	431.80	457.20	482.60
20	508.00	533.40	558.80	584.20	609.60	635.00	660.40	685.80	711.20	736.60
30	762.00	787.40	812.80	838.20	863.60	889.00	914.40	939.80	965.20	990.60
40	1016.00	1041.40	1066.80	1092.20	1117.60	1143.00	1168.40	1193.80	1219.20	1244.60
50	1270.00	1295.40	1320.80	1346.20	1371.60	1397.00	1422.40	1447.80	1473.20	1498.60
60	1524.00	1549.40	1574.80	1600.20	1625.60	1651.00	1676.40	1701.80	1727.20	1752.60
70	1778.00	1803.40	1828.80	1854.20	1879.60	1905.00	1930.40	1955.80	1981.20	2006.60
80	2032.00	2057.40	2082.80	2108.20	2133.60	2159.00	2184.40	2209.80	2235.20	2260.60
90	2286.00	2311.40	2336.80	2362.20	2387.60	2413.00	2438.40	2463.80	2489.20	2514.60

Use in conjunction with above table.

Example: Find equivalent mm. for 84 5/8".

84" = 2133.60 mm.

5/8" = 15.875 mm.

84 5/8" = 2149.475 mm.

CALIFORNIA

Proposition 65 Warning

Diesel engine exhaust and some of its constituents are known to the State of California to cause cancer, birth defects, and other reproductive harm