

WINGET

OPERATING INSTRUCTIONS & SPARE PARTS LIST 4S VHD DIESEL DUMPER (HAMWORTHY AXLES)

FIRST ISSUED DECEMBER 1979

REPRINTED JULY 2002

**WINGET LIMITED
PO BOX 41
EDGEFOLD INDUSTRIAL ESTATE
PLODDER LANE
BOLTON
LANCS
BL4 OLS
TEL: ++ 44 (0) 1204 854650
FAX: ++ 44 (0) 1204 854663
service@winget.co.uk
parts@winget.co.uk
winget.co.uk**

INTRODUCTION

This Parts & Operators Manual is a re-print of the manual last published in 1981 and contains some amended part numbers.

Health & Safety legislation and working practices applicable to Site Dumpers, both 2 and 4 wheel Drive, Rigid Chassis and Articulated Chassis have changed considerably in the years since this manual was last published and immediately following this Introduction are notes on the Safe Use of Site Dumpers. These notes supersede and replace all previous 'Dumper Safety' notes issued with Winget 4S Variable Height Discharge Two Wheel Drive Dumpers

Reference is made on a number of pages to 'bolt c/w nut and washer', this no longer the case, fixings such as nuts, bolts, screws and washers should be ordered as individual items. A number of Whitworth and B.S.F fixings are now no longer available, in these cases the nearest metric equivalent size will be supplied.

The contents of this manual although correct at the time of publication, may be subject to alteration by the manufacturers without notice and Winget Limited can accept no responsibility for any errors or omissions contained within the following pages. Nor can we accept any liability whatsoever arising from the use of this manual howsoever caused.

Winget Limited operate a policy of continuous product development. Therefore, some illustrations or text within this publication may differ from your machine.

WINGET LIMITED
PO BOX 41
EDGEFOLD INDUSTRIAL ESTATE
PLODDER LANE
BOLTON
LANCS
BL4 OLS
TEL ++ 44 (0) 1204 854650
FAX ++ 44 (0) 1204 854663
E mail service@winget.co.uk
parts@winget.co.uk
www.winget.co.uk

Safety is the responsibility of all persons working with this machine. Think "safety" at all times. ***Read and remember the contents of this handbook.***

The safe working recommendations for specific tasks are found with the instructions for the relevant operation in this Handbook.

MACHINE MODIFICATION

WARNING Any modifications to the machine will affect its working parameters and safety factors. Refer to the Manufacturers before fitting any non-standard equipment or parts.



The Manufacturers accept no responsibility for any modifications made after the machine has left the factory, unless previously agreed by the Manufacturers in writing; the Manufacturers will accept no liability for damage to property, personnel or the machine if failure is brought about due to such modifications, or fitment of spurious parts.

TRAINING

WARNING Only trained operators should use this machine.



Operators should hold an appropriate full motor vehicle driving licence and undergo both a safety awareness course and a driver training course for Site dumpers run by the C.ITB or equivalent body leading to the award of a CTA.

It is strongly recommended that operators read the H.S.E. publication "Safe Working with Small Dumpers" which is available from government bookshops (HMSO) or from other bookshops quoting the following number ISBN 011 8836935. Another useful publication is British Standard number BS 6264, "Procedure for Operator Training For Earth Moving Machinery" available from the British Standard Institution.

RUNNING-IN

WARNING While a gradual 'running-in' of a new engine is not necessary, it is extremely important that the instructions given in *Section 2 "Operation"* on "Running-in a new engine" should be followed very closely during the first fifty hours of operation.



DRIVING

WARNING **NEVER** use the machine for purposes other than those for which it was designed. This machine was designed to carry loads such as soil, clay, sand, wet concrete, stone or other similar materials. It was not designed to carry loads which may move around in the skip uncontrollably, nor to carry any loads or materials which overhang the skip in any way. If in any doubt as to the suitability of this machine for a particular task, contact your nearest Distributor or the Manufacturer for advice.



ALWAYS be aware of local and national regulations governing the use of the machine.

NEVER commence work with the machine until the "Daily (or every ten hours)" service checks have been made. (*See Service Section* for details)

ALWAYS check wheel nut tightness daily.

NEVER carry passengers.

Ensure that the seat is securely fixed to the machine. Where seat belt restraints are fitted as part of Rops/Fops protection they must be worn. Check that the seat belt is in good condition, free from cuts and frayed edges.

ALWAYS remain in the driving seat whenever the engine is running. Never attempt to operate any controls unless seated.

ALWAYS apply the parking brake before leaving the driver's seat.

NEVER dismount with the engine running, and never leave the machine unattended with the key in the starter switch.

When Battery Isolators are fitted they must be activated only when the engine is turned off except in cases of emergency.

Activating a Battery Isolator when the engine is running can result in damage to the electrical components and circuits.

NEVER fill the fuel or hydraulic tanks with the engine running.

ALWAYS drive only on surfaces that are known to be stable.

ALWAYS keep the floor plates and walkways clean.

NEVER drive the machine close to the edge of any excavation. Always use effective wheel stops to prevent the machine running close to the edge. Make sure that the stops are in proportion to the size of the wheels and are set sufficiently far enough back from the edge of any excavation to prevent the weight of the load causing a collapse.

NEVER adjust the tyre pressures in an attempt to improve traction on soft ground or obtain a softer ride on hard ground. Incorrectly adjusted tyres can affect the steering and handling characteristics.

NEVER attempt to free a machine which is 'bogged down' by pushing with the bucket of a backhoe loader, tracked excavator or other similar machine.

NEVER make unnecessary "crash stops" when travelling at speed, especially in forward direction.

NEVER work under an unpropped skip. If the dumper was supplied with a special skip support always ensure that it is used.

SKIPS AND LOADING

WARNING NEVER exceed the rated payload. The weights of all loads above skip water level must be checked.



NEVER remain on the machine when loading the skip with excavators or loaders. Stop the engine, apply the parking brake, dismount, and stand well clear.

ALWAYS ensure that the load is evenly distributed in the skip.

NEVER carry loads or heap materials in such a manner as to affect the forward vision.

ALWAYS take extra care when tipping non free running loads.

NEVER use the skip in a tipped position to bulldoze heaped materials level or to backfill material into excavations.

TOWING

WARNING NEVER attempt to start the engine of a dumper by towing or pushing.



Dumpers are not designed as towing vehicles. However, trailers may be towed provided that:

- 1 The combined weight of the trailer and its load does not exceed the dumper "drawbar pull of 250kg (2500N)" and dumper "drawbar load of 50kg (500N)".
- 2 Trailers may be towed in first gear on level dry ground, provided a purpose made towing pin is used.
- 3 The dumper skip must be loaded with half the rated payload to ensure tyre adhesion when braking.

NEVER tow loads up, down or across gradients.

GRADIENTS

WARNING NEVER operate **Two Wheel Drive rigid chassis dumpers** on any gradients which exceed 10% (1 in 10), or across gradients which exceed 10% (1 in 10).



ALWAYS remember that slippery or loose surface conditions can adversely affect safe machine operation, including braking, particularly on gradients.

ALWAYS choose routes that avoid steep, slippery or loose gradients.

NEVER coast down gradients. Always negotiate gradients in first gear.

ALWAYS drive forwards up gradients when loaded.

ALWAYS reverse down gradients when loaded.

ALWAYS keep the load facing uphill.

NEVER park on a gradient. If this is unavoidable, *ALWAYS* chock the wheels.

NEVER attempt to turn on a gradient

NEVER tow up, down or across a gradient.

NEVER operate high discharge or rotating skips on gradients.

HYDRAULICS

WARNING *ALWAYS* "Dump" residual pressure from the system before leaving the machine or before carrying out any maintenance or adjustments.



If maintenance work requires the skip to be in the raised position, then it must be raised and supported before dumping the pressure.

Dump pressure by switching off the engine, then moving the hydraulic control lever several times in each direction.

NEVER leave the machine unattended with pressure in the system.

ALWAYS purge hydraulic rams before commencing work. With the engine running operate the hydraulic control to fully extend and retract the rams.

ALWAYS practise the greatest cleanliness in maintaining hydraulic components.

SERVICING

WARNING *ALWAYS* report any defect at once, before an accident or consequential damage can occur.



ALWAYS conform to service schedules except where:

- 1 Warning lights or warning indicators call for immediate attention.
- 2 Adverse conditions necessitate more frequent servicing.

ALWAYS wear correctly fitting protective clothing. Loose or baggy clothing can be extremely dangerous when working on running engines or machinery.

ALWAYS, where possible, work on or close to engines or machinery only when they are stopped. If this is not practical, remember to keep tools, test equipment and all parts of your body well away from the moving parts.

ALWAYS "Dump" pressure from the hydraulic system before carrying out any kind of maintenance or adjustment. (*see Service - Hydraulic system*).

ALWAYS avoid contact with exhaust pipes, exhaust manifolds and silencers when the engine is running; these can be very hot.

ALWAYS work out of doors, or in a well-ventilated area.

NEVER run an engine in an enclosed space. Exhaust fumes in enclosed areas can kill.

ALWAYS disconnect battery cables and remove battery before using an external charger, carrying out welding repairs or to prevent unauthorised usage when unattended or during a repair.

NEVER allow unqualified personnel to attempt to repair, remove or replace any part of the machine, or anyone to remove large or heavy components without adequate lifting tackle.

NEVER attempt to modify or repair Rops Frames or Fops Canopies by welding, drilling or any other means. Attempts to do so will invalidate Rops/Fops Certification.

ALWAYS obtain advice before mixing oils; some are incompatible. If in doubt drain and refill.

NEVER allow oils and fuels to come into regular contact with skin. This can lead to serious skin diseases including, medical evidence suggests, skin cancer. *ALWAYS* wear protective gloves when handling oils and fuels whether topping up, draining or refilling. *ALWAYS* wash hands if oils or fuels come into contact with the skin.

Many liquids used in this machine are harmful if taken internally or splashed into the eyes. In the event of accidentally swallowing oils, fuels, anti-freeze, battery acid etc, *DO NOT* encourage vomiting, seek qualified medical assistance immediately.

ALWAYS dispose of waste oils and fuels into waste oil storage tanks. If storage tanks are not available consult your distributor or local authority for addresses of local designated disposal points. It is illegal to dispose of waste oil into drains or water courses or to bury it.

Equipment which includes friction materials will sometimes contain asbestos. When removing friction material dust from components, such as when servicing brakes or clutches, do not blow out with an airline; it could be harmful to inhale the dust. Remove the dust with a vacuum cleaner or wipe clean with a damp rag. Waste should be placed in a sealed container, marked, and disposed of in accordance with local or national regulations.

The accumulated dust found in clutch housings may contain lead/antimony. No food should be eaten at a work place contaminated by this dust. Hands must be washed before eating. Do not blow out dust with an airline.

NEVER work under an unpropped skip. ***If the dumper was supplied with a special Skip Support always ensure that it is used.***

ALWAYS ensure that when using a starting handle that it is clean and in good condition. Keep the engine starting dog and the part of the starting handle that mates with it lightly lubricated (*Refer to the Engine Handbook*).

PREPARATION FOR USE

BEFORE THE DUMPER IS PUT INTO SERVICE, ALWAYS CHECK THE FOLLOWING POINTS –

1. **Engine**
Check the oil level on the dipstick (A), topping up if necessary to the full mark. See also 'Recommended Lubricating Oils', page 14.
2. **Gearbox**
Check the oil level on the dipstick (B), topping up if necessary to the full mark. See also 'Recommended Lubricating Oils' page 14.
3. **Drive Axle**
Remove level/filler plug (C) and check that oil is up to bottom of hole. Top up if necessary. See also 'Recommended Lubricating Oils', page 14.
4. **Fuel Tank**
Fill tank (D) with diesel oil until approximately 1" from the top.

NOTE: See Periodic Maintenance (2).

5. **Hydraulic Tank**
Fill the hydraulic tank (E). Before removing the cap, clean the surrounding area, to prevent the possible entry of foreign matter. DO NOT MIX OILS. See also 'Recommended Lubricating Oils', page 14.
6. **Brake System**
Ensure that the brake master cylinder reservoir (F) is full of brake fluid. Top up if necessary, to within 1/4" of the top of the reservoir. Use only Girling Crimson Brake Fluid.
7. **Miscellaneous**
Check all wheel nuts for tightness.
Check all nuts and bolts for tightness. Loose nuts and bolts may lead to damage not covered by the Dumper Warranty.

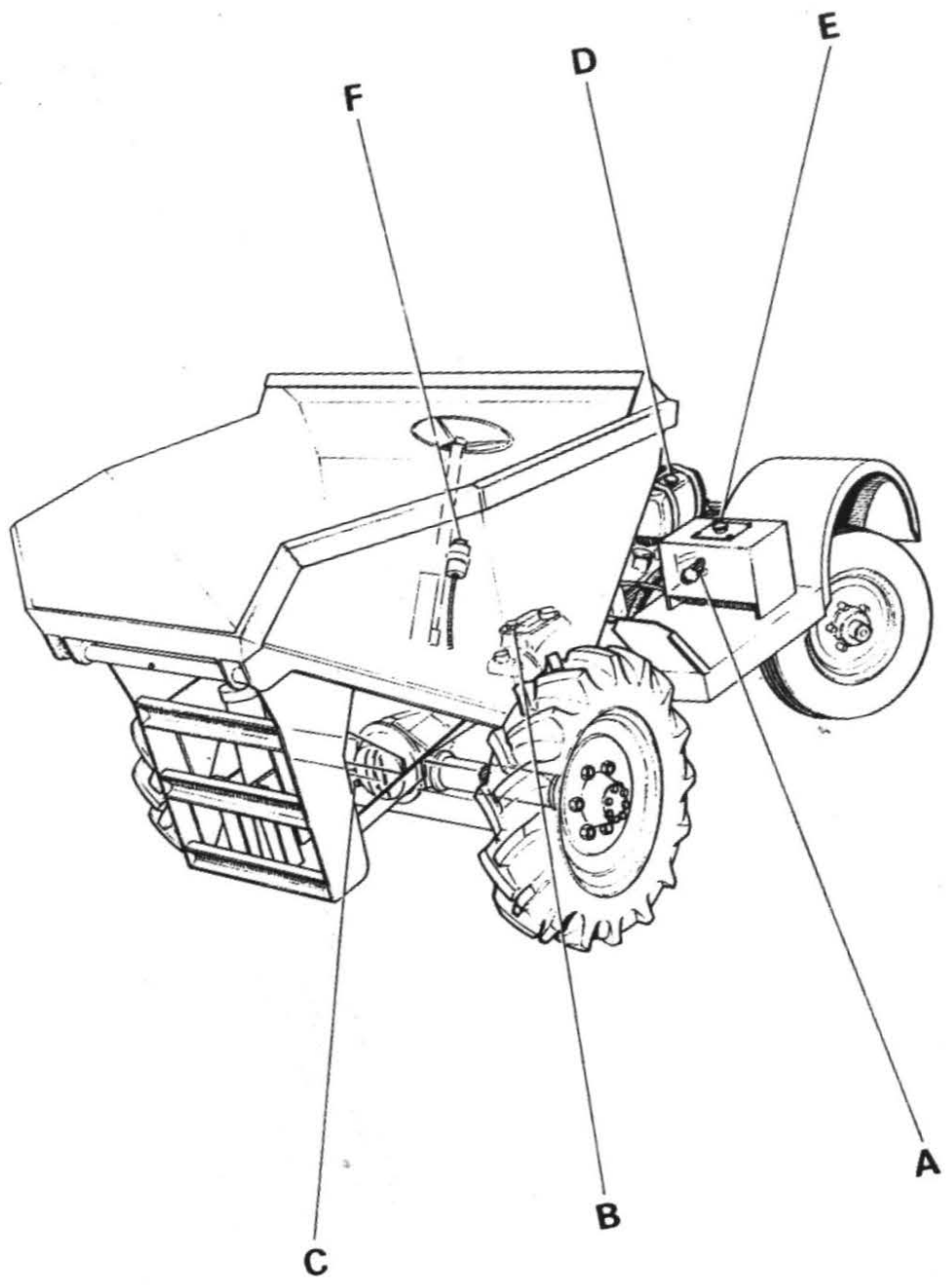

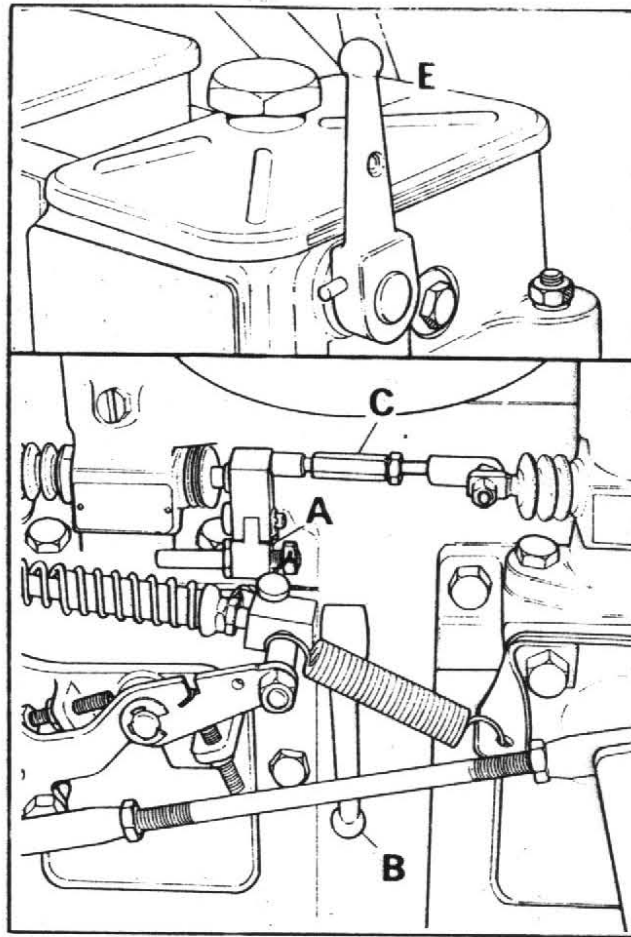

FIG 4

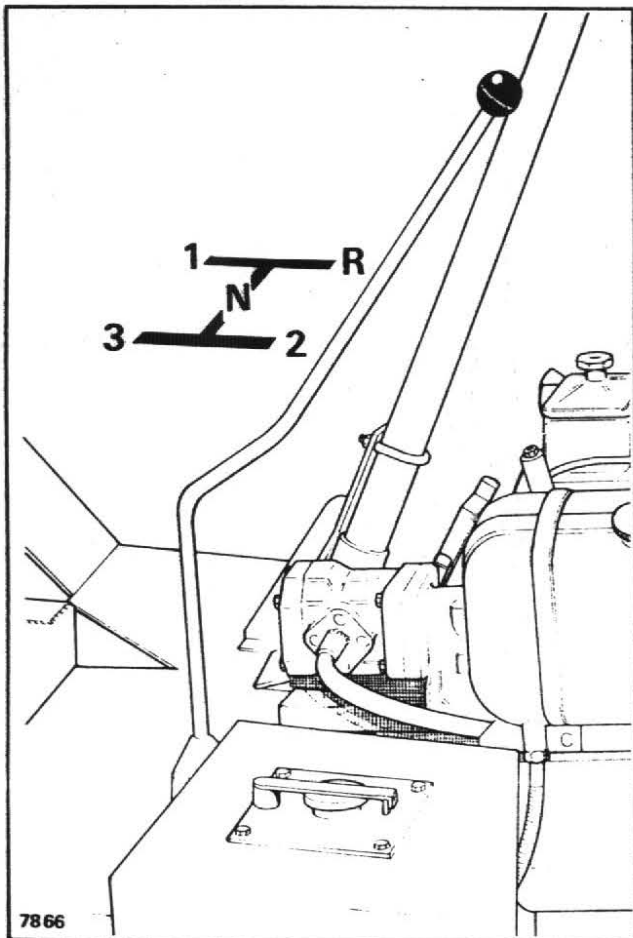

FIG 5

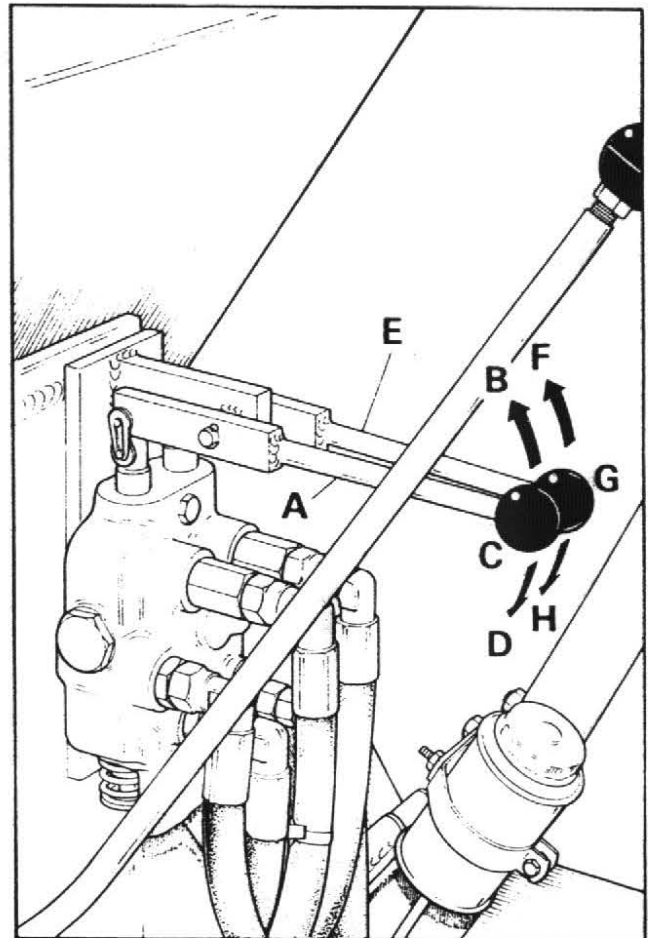

FIG 6

OPERATION

Starting

Fig. 4 (Petter)

1. Lift red-painted overload stop (A) situated on fuel pump immediately above priming lever (B), and move fuel pump racks (C) into fully-open position (PETTER ENGINE).
2. Operate priming lever (B) six times.

NOTE: This is unnecessary if engine is already warm.

3. Lift decompression levers (E), positioned on top of engine and turn engine as fast as possible using starting handle. When engine is turning at a good speed, knock down decompression levers and engine should fire.
4. If engine does not fire, lift decompression lever and slowly crank engine a few times before attempting to start again. Where ambient temperature is 5^oF (-15^oC) or below, a cold starting aid should be fitted.

Stopping

Fig. 4 (Petter)

Hold the fuel pump rack (C) in the fully forward position, or lift the priming lever to the horizontal, until engine stops and then release (PETTER ENGINE).

IMPORTANT

1. DO NOT stop engine by means of decompression levers, this will lead to damaged valve seats and cylinder head joints.
2. DO NOT stop engine by closing fuel tap or by allowing fuel tank to run dry. This will allow air into fuel lines and necessitate bleeding and priming system.

Gear Shift Lever

Fig. 5

The dumper is fitted with three forward gears and one reverse gear. When changing gear, the clutch pedal is used in the normal manner.

Skip Control Lever

Fig. 6

1. Control lever (A) has three positions, DUMP (B), HOLD (C) and RETURN (D).
2. Pull lever up to DUMP (B) to deposit load.
3. Push lever down to RETURN (D) to return the skip to the carrying position.

NOTE: If lever is released when in DUMP or RETURN positions, it will automatically return to HOLD (C) position and motion of skip will cease. In this way, speed at which load is deposited can be finely controlled.

Variable High Discharge Control Lever

Fig. 6

1. Control lever (E) has three positions, UP (F), HOLD (G) and DOWN (H).
2. Pull lever up to UP (F) to raise discharge height.
3. Push lever down to DOWN (H) to lower discharge height.

NOTE: If lever is released when in UP or DOWN positions, it will automatically return to HOLD (G) position and motion of skip will cease. In this way, height at which skip discharges can be finely controlled.

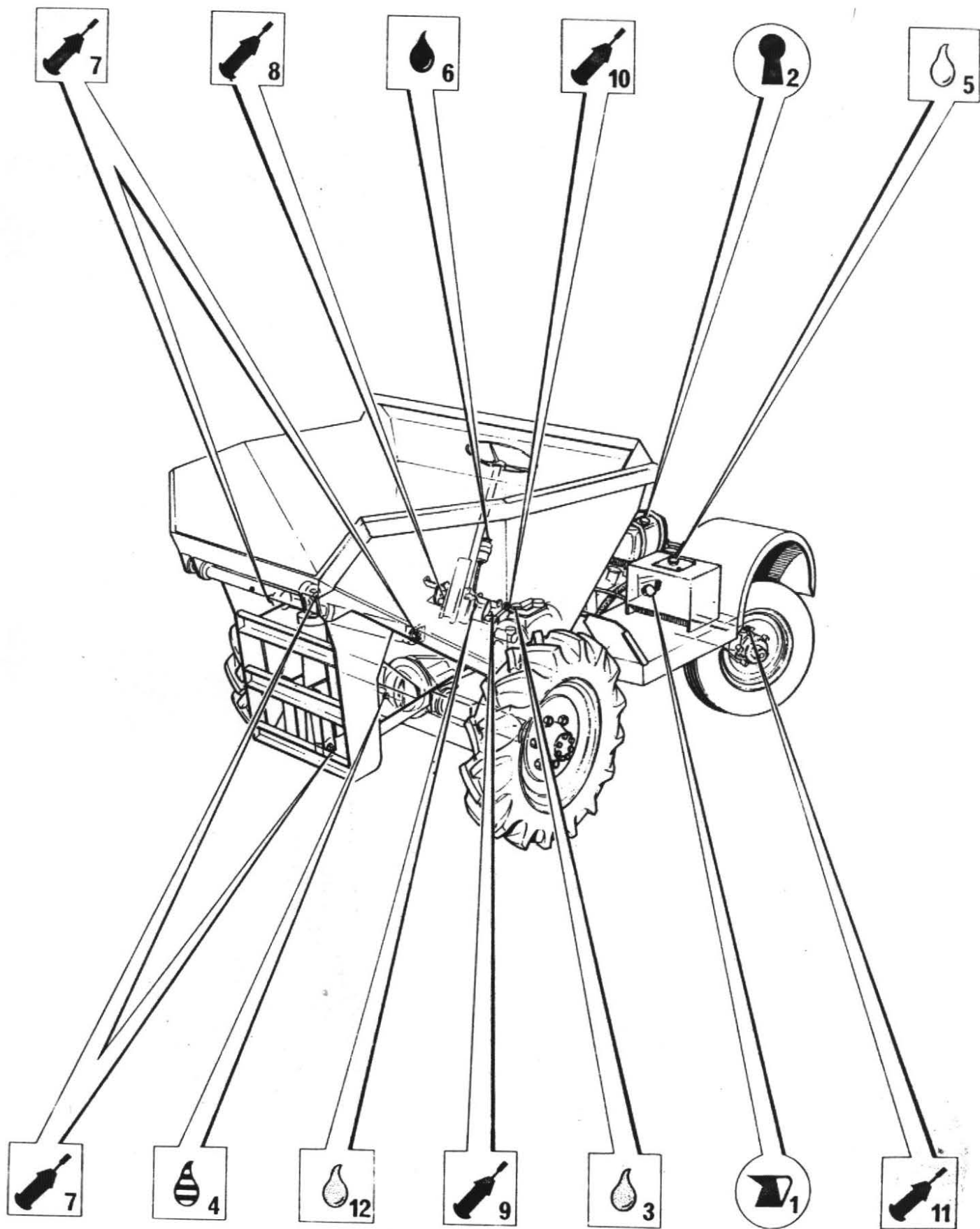

GENERAL MAINTENANCE

Lubrication

Daily

		No. of points
○ 1	Engine oil	1
○ 2	Fuel Tank	1

Weekly

3	Gearbox - oil	1
4	Drive Axle - oil	1
5	Hydraulic Tank - oil	1
6	Brake Master Cylinder Reservoir - brake fluid	1
□ 7	Ram Bearings - grease (variable height ram)	2
□ 8	Footbrake Pedal - grease	1
9	Clutch Pedal - grease	1
10	Clutch Cross Shaft - grease	2
11	Steering Hub and Ball Ends – grease	10
12	Steering Box - oil	1

Key

	Engine oil
	Gearbox oil
	Axle oil
	Hydraulic fluid
	Brake fluid
	Grease gun
	Diesel fuel

- NOTES:**
1. Rear Axle Articulation Points consist of silentbloc bushes and do not require lubrication.
 2. For full details on the lubrication and maintenance of the engine, refer to the appropriate manufacturer's manual.

Recommended Lubricating Oils

See page 14

Periodic Maintenance

1. DAILY check engine oil level and fill to full mark on dipstick, if necessary.
2. DAILY fill fuel tank, or as often as proves necessary, to within approximately 1" of top of tank. Maintain a minimum of 2" of fuel in tank.
3. WEEKLY check oil level in gearbox and fill to full mark on dipstick, if necessary.
4. WEEKLY remove level/filler plug from drive axle. Oil level should be to bottom of hole. Top up, if necessary.
5. WEEKLY check oil level in hydraulic tank. Always clean surrounding area before removing cap, to prevent possible entry of foreign matter. Fill tank, if necessary, to within 1" of top.
6. WEEKLY check brake fluid in master cylinder reservoir and top up if necessary, to within 1/4" of top.
7. WEEKLY apply grease to all grease nipples.
8. WEEKLY check all wheel nuts and tighten, if necessary.
9. OCCASIONALLY check all nuts and bolts and tighten if necessary.

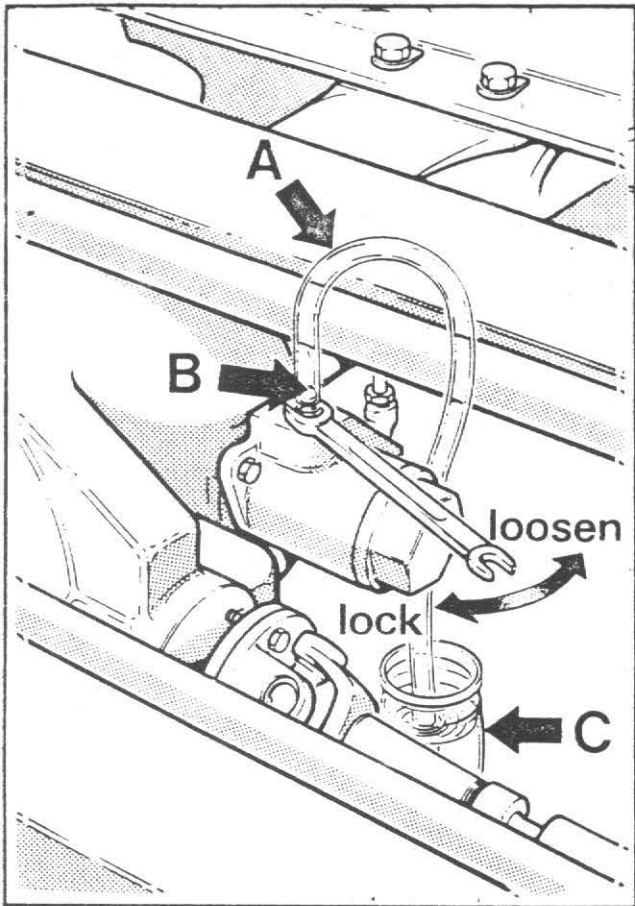

FIG 4

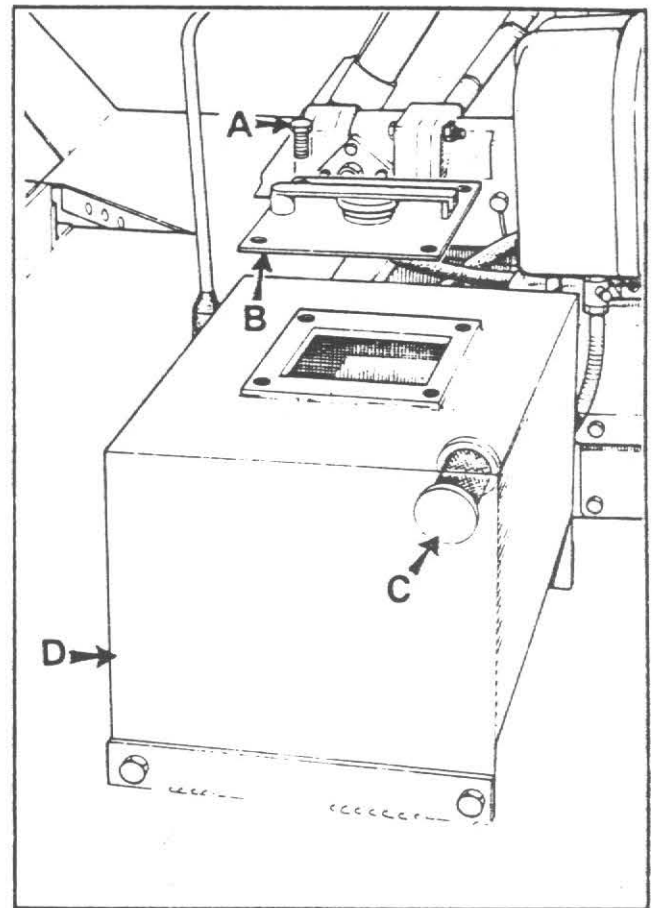

FIG 5

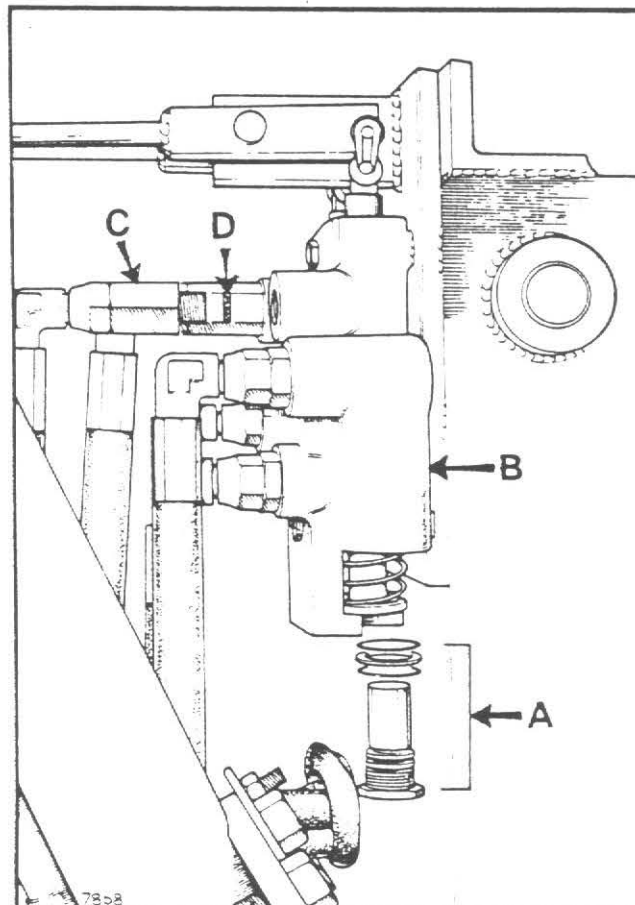

FIG 6

Brake System

The brake system is designed to require the minimum of maintenance, and, providing that the hydraulic fluid in the reservoirs is not allowed to fall below the recommended level, no defects should normally occur. Fluid loss must be supplemented by topping up the reservoir with Girling Crimson Brake Fluid. No other fluid may be used. If air is present in the system, it will be indicated by sluggish response of the brake or by spongy action of the brake pedal. This may be due to air being introduced at a loose joint or by the reservoir fluid level being allowed to fall to a very low level. These defects must be remedied immediately and the complete system bled.

To bleed the system, proceed as follows. During the operation it is essential that the reservoir level is kept topped up to prevent further air from being drawn into the system. Only use new fluid for topping-up.

Fig. 1

1. Check that all connections are tight and all bleed screws are closed.
2. Fill reservoir with Girling Crimson Brake Fluid.
3. Attach bleeder tube (A) to bleed screw (B) of one wheel and immerse other end in a small quantity of brake fluid contained in a glass jar (C). Slacken bleed screw and operate brake pedal up and down through its full stroke until fluid pumped into jar contains no air bubbles. Hold down pedal and close bleed screw. Remove bleeder tube and release pedal.
4. Repeat on other wheel.
5. Lock both bleed screws and top up reservoir to correct level.
6. Apply normal working load on brake pedal for two or three minutes and examine entire system for leaks.

Main Hydraulic System

The main hydraulic system controls the dumping and return of the skip. If the skip fails to operate or does so extremely slowly, carry out the following procedures until the fault is rectified.

1. Check that hydraulic tank is full of oil.

Fig. 2

2. a) Remove four setscrews (A) securing filler cap assembly (B) and remove assembly.
b) Unscrew suction filter (C) from inside of tank (D) and wash in white spirits. Dry with moisture-free compressed air.
c) Replace suction filter and filler cap assembly.

NOTE: If suction filter cannot be thoroughly cleaned, fit a new one.

3. Check that hydraulic pressure is correct.
a) Fit a 2500 p.s.i. gauge into hydraulic line to base of rams.
b) Operate control lever(s) to dump skip (raise skip frame) and check that pressure reading on gauge is 2000 p.s.i. when ram is fully-extended and relief valve is 'blowing'.

Fig. 3

4. Remove relief valve cartridge (A) (hexagon head) from end of control valve (B) opposite to control lever(s) and replace with a new one.
5. Remove hose adaptor (C) from control valve, remove hexagonal orifice plate (D) and wash in white spirit. Dry using moisture-free compressed air. DO NOT poke wire, etc. into orifice. Re-fit plate and hose adaptor, with slot of orifice plate facing outwards.

If none of these procedures correct the fault, contact your local Winget agent.

Periodically check the hose between the pump and the hydraulic tank to ensure that it is not deformed. Any deformation in the hose may result in a vertical flow and damage to the pump.

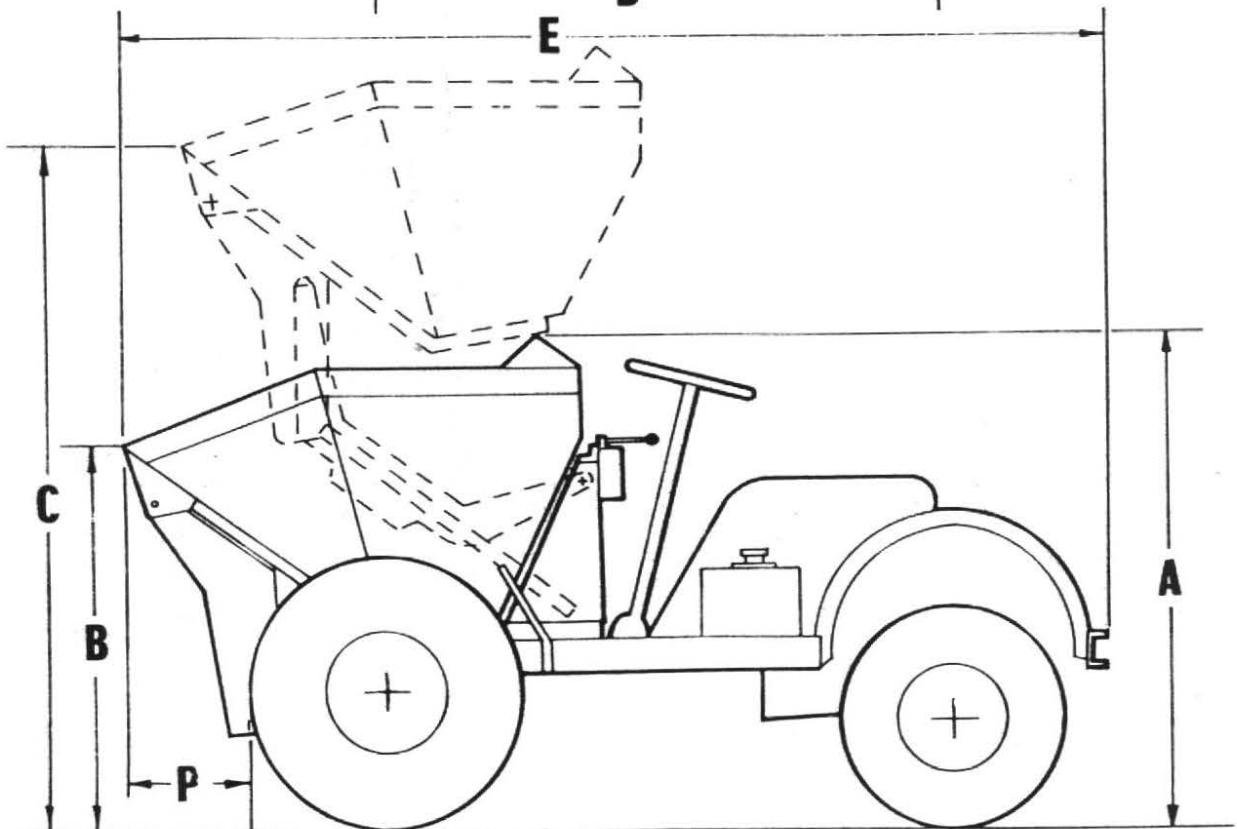
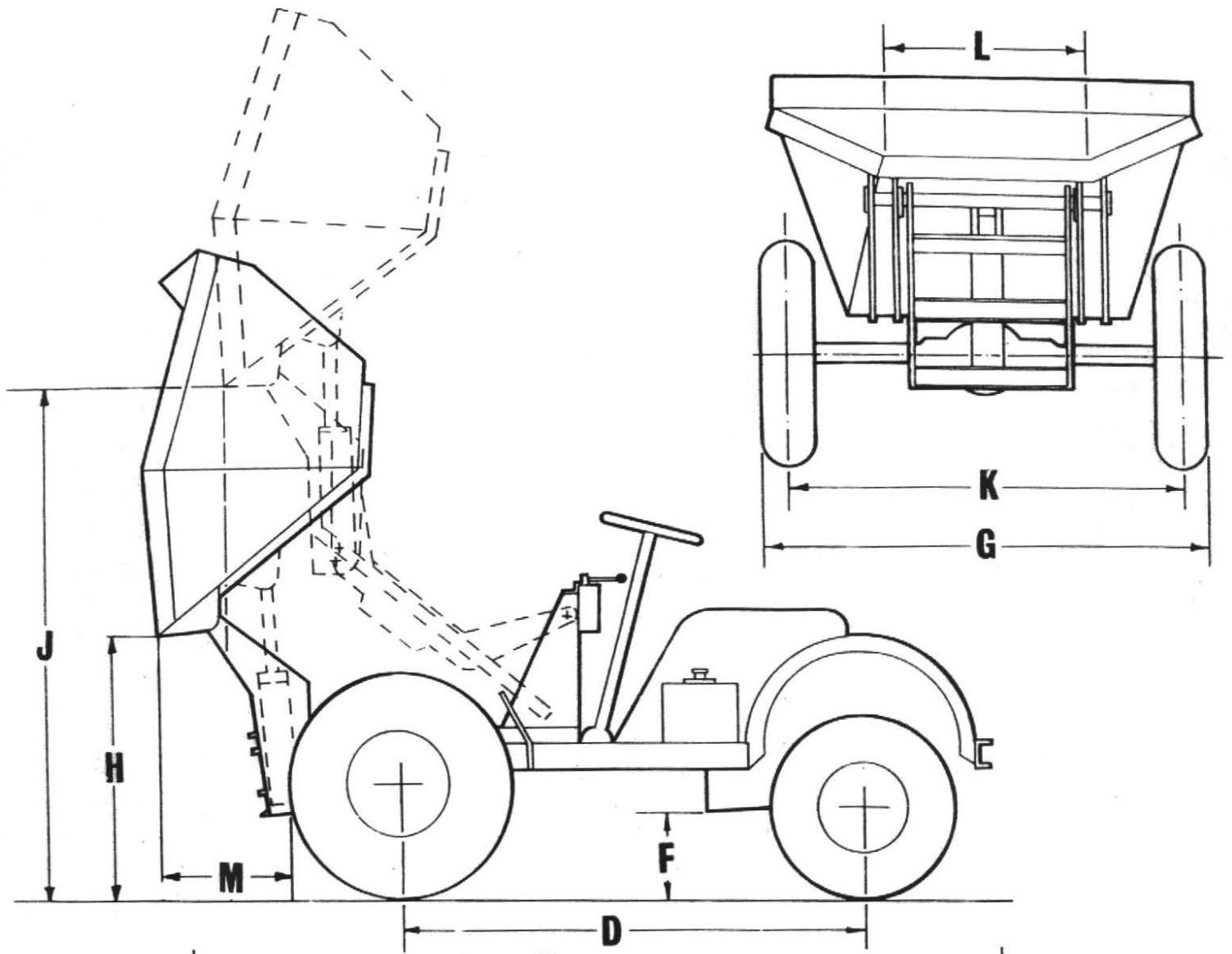

SPECIFICATION
4S VARIABLE HIGH DISCHARGE DUMPER

Dimensions

A	Overall height	5' 3"	(1.60 m)
B	Skip loading height low	4' 3"	(1.30 m)
C	Skip loading height high	7' 2"	(2.18 m)
D	Wheelbase	5' 9"	(1.75 m)
E	Overall length	10' 6"	(3.20 m)
F	Ground clearance	10"	(0.25 m)
G	Overall width	5' 6"	(1.68 m)
H	Skip ground clearance when tipped low	3' 7"	(1.09 m)
J	Skip ground clearance when tipped high	6' 6"	(1.98 m)
K	Wheel track	4' 10"	(1.47 m)
L	Skip discharge width	2' 9"	(0.84 m)
M	Skip discharge distance low	1' 10"	(0.56 m)
N	Skip discharge distance high	12"	(0.30 m)

Skip Capacities

Water Level	24 ft ³	(0.68 m ³)
Struck Level	30 ft ³	(0.85 m ³)
Heaped	37 ft ³	(1.05 m ³)

Road Speeds

	M.P.H.	Km/H
1st forward	3.00	4.8
2nd forward	6.75	10.8
3rd forward	12.5	20.1
Reverse	3.25	5.2

Tank Capacities

Diesel fuel tank		
Hydraulic oil tank	4 imp. galls	(18 litres)
Turning circle	27' 0"	(8.25 m)
Vehicle weight	1 ton 11 cwt. 3qrs.	(1613 kg.)
Hydraulic relief valve	2000 lb/in ²	(140 kg/cm ²)
Working pressure	1500 lb/in ²	(105 kg/cm ²)
Rear axle articulation	1' 2"	(0.35 m)

RECOMMENDED LUBRICATING OILS

COMPANY		ENGINE	DRIVE AXLE		GEARBOX	WHEEL BEARINGS & OTHER GREASE POINTS	HYDRAULIC SYSTEM
(U.K.) ESSO	SUMMER	ESSOLUBE HDX 20W	IL 2082		ESSOLUBE HDX 30	BEACON 2	NUTO H 44
	WINTER						
(Overseas)	ABOVE 32°C 0°C – 32°C BELOW 0°C	ESSOLUBE HDX 30 ESSOLUBE HDX 20W ESSOLUBE HDX 10W	IL 2082 IL 2082		ESSOLUBE HDX 30	BEACON 2	NUTO H 54 NUTO H 44 NUTO H 40
(U.K.) CASTROL	SUMMER	DEUSOL CRB 20	AGRICASTROL AS		DEUSOL CRI 30	CASTROL SPHEEROL APT 2	
	WINTER						
(Overseas)	ABOVE 32°C 0°C – 32°C BELOW 0°C	DEUSOL CRB 30 DEUSOL CRB 20 DEUSOL CRB 10	AGRICASTROL AS AGRICASTROL MD		DEUSOL CRI 30	CASTROL SPHEEROL APT 2	CASTROL HYPSPIN AWS 32
(U.K.) SHELL	SUMMER	ROTELLA SX OIL 20/20W	S.7142 (INITIAL FILL) SPIRAX EP 80 (Top up only)		ROTELLA SX OIL 30	RETINAX A	
	WINTER						
(Overseas)	ABOVE 32°C 0°C – 32°C BELOW 0°C	ROTELLA SX OIL 30 ROTELLA SX OIL 20/20W ROTELLA SX OIL 10W	S.7142 (INITIAL FILL) SPIRAX EP 80 (Top up only) S.7224 (INITIAL FILL) SPIRAX HD 75 (Top up only)		ROTELLA SX OIL 30	RETINAX A	TÉLLUS OIL 27
(U.K.) BP	SUMMER	VANELLUS M20	B.P. HYDRAULIC TF-8		VANELLUS M30	ENERGREASE L2	
	WINTER						
(Overseas)	ABOVE 32°C 0°C – 32°C BELOW 0°C	VANELLUS M30 VANELLUS M20 VANELLUS M10W	B.P. HYDRAULIC TF-8 B.P. TRACTRAN (Top up only)		VANELLUS M30	ENERGREASE L2	ENERGOL HLP 65
(U.K.) MOBIL	SUMMER	DELVAC 1220	MOBIL FLUID 422		DELVAC 1230		
	WINTER					MOBILGREASE MP	
		ABOVE 32°C	DELVAC 1230				DTE 24
		0°C – 32°C	DELVAC 1220	MOBIL FLUID 422		MOBILGREASE SUPER	
(Overseas)	BELOW 0°C	DELVAC 1210	MOBIL FLUID 427				
ALL TEMPERATURES		DELVAC SPECIAL 10W-30			DELVAC 1230		
(U.K.) WALKERS CENTURY	SUMMER	CENTLUBE HD 20	CENTLUBE F.76 COMPOUND		CENTLUBE HD 30	REGULUS A2	CENTURY PWL A HYD. OIL
	WINTER						
		ABOVE 32°C 0°C – 32°C BELOW 0°C	CENTLUBE HD 30 CENTLUBE HD 20 CENTLUBE HD 10	CENTLUBE F.76 COMPOUND CENTLUBE E.76 COMPOUND		CENTLUBE HD 30	REGULUS A2
(Overseas)							

IN THE UNLIKELY EVENT OF THE ABOVE OILS NOT BEING AVAILABLE
EQUIVALENT OILS SUPPLIED BY A REPUTABLE MANUFACTURER MAY BE USED

SPARE PARTS SECTION

LIST OF CONTENTS

TITLE	PAGE NO.
CHASSIS	20-21
SKIP & FRAME	22-23
CLUTCH ASSEMBLY	24
GEARBOX	25-28
DRIVE AXLE (HAMWORTHY) DIFFERENTIAL, HALFSHAFT & BRAKE	29-30
AXLE CASING & HUB ASSEMBLY	31-32
PROPSHAFT & COUPLING	33
DRIVE WHEELS/FRONT	34
STEERING WHEELS/REAR	35
STEERING AXLE	36-37
STEERING GEAR (CAM & ROLLER)	38-39
STEERING GEAR (RECIRCULATING BALL)	40-41
PEDALS, CONTROLS & HANDBRAKE	42-43
BRAKE PIPES & FITTINGS	44
MASTER CYLINDER	45
HYDRAULICS	46-47
HYDRAULIC PUMP	48
TIPPING CYLINDER	49-50
LIFTING CYLINDER	51
CONTROL VALVE	52-53

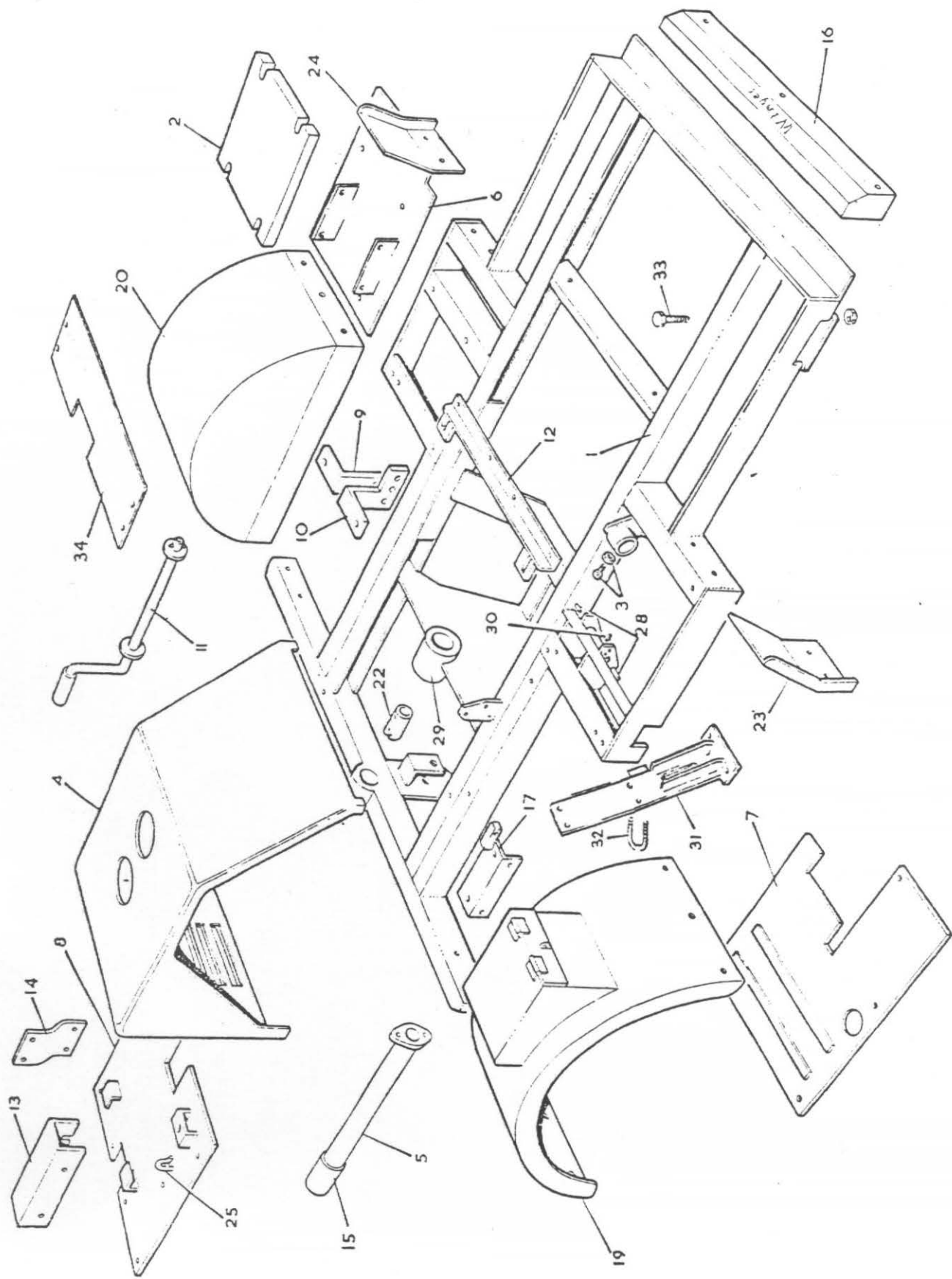

CHASSIS, WINGS, ETC.

Item No.	Part No.	Description	Qty.
1		Chassis Frame (Petter)	1
2	C.181	Ballast weight (side)	1
3	C.212	Locking bolts and nuts	2
4	F.510	Engine Cover (Petter)	1
5	5S/111	Exhaust Pipe (Petter)	1
6	4SH 58	Footplate L.H. (Petter)	1
7	5S/104	Footplate R.H.	1
8	5S/105	Rear Cover (Petter)	1
9	T/9	Gearbox Support R.H.	1
10	T/10	Gearbox Support L.H.	1
11	F.534	Starting Handle (Petter)	1
12	5S/110	Engine Cover Support (Petter)	1
13	F.539	Engine Fuel Tank Support (Petter)	1
14	F.540	Engine Fuel Tank Support (Petter)	1
15	5S-111B	1½" BSP Socket (Petter)	1
16	C.147	Ballast Weight (Front)	1
17	4SH 60	Hydraulic Valve Mtg Bracket	1
18	20072 A01	Seat (Not Illustrated)	1
19	5ST 105	Rear Mudwing R.H.	1
20	L.252B	Rear Mudwing L.H.	1
21	69S.2C	Setscrew-Seat fixing (Not Illustrated)	4
22	L.259P	Starter Dog (Petter)	1
23	5S/108. R.H.	Mudflap, Drive Wheel R.H.	1
24	5S/108. L.H.	Mudflap, Drive Wheel L.H.	1
25	L.287B	Starting Handle Clip and Spring	1
26	41S.4A	Springwasher - Seat fixing (Not Illustrated)	4
27			
28	WB.0808	Accelerator Pedal Bush	2
29	4S/100B21A	Starter Dog Shroud (Petter)	1
30	TST	Grease Nipple	1
31	4SHL 108	Steering column support	1
32	C.125	U Bolt and nuts	2
33		Axle Mtg. Bolt M16 x 60 mm long & locknut	8
34	4SH 64	Gearbox Cover	1

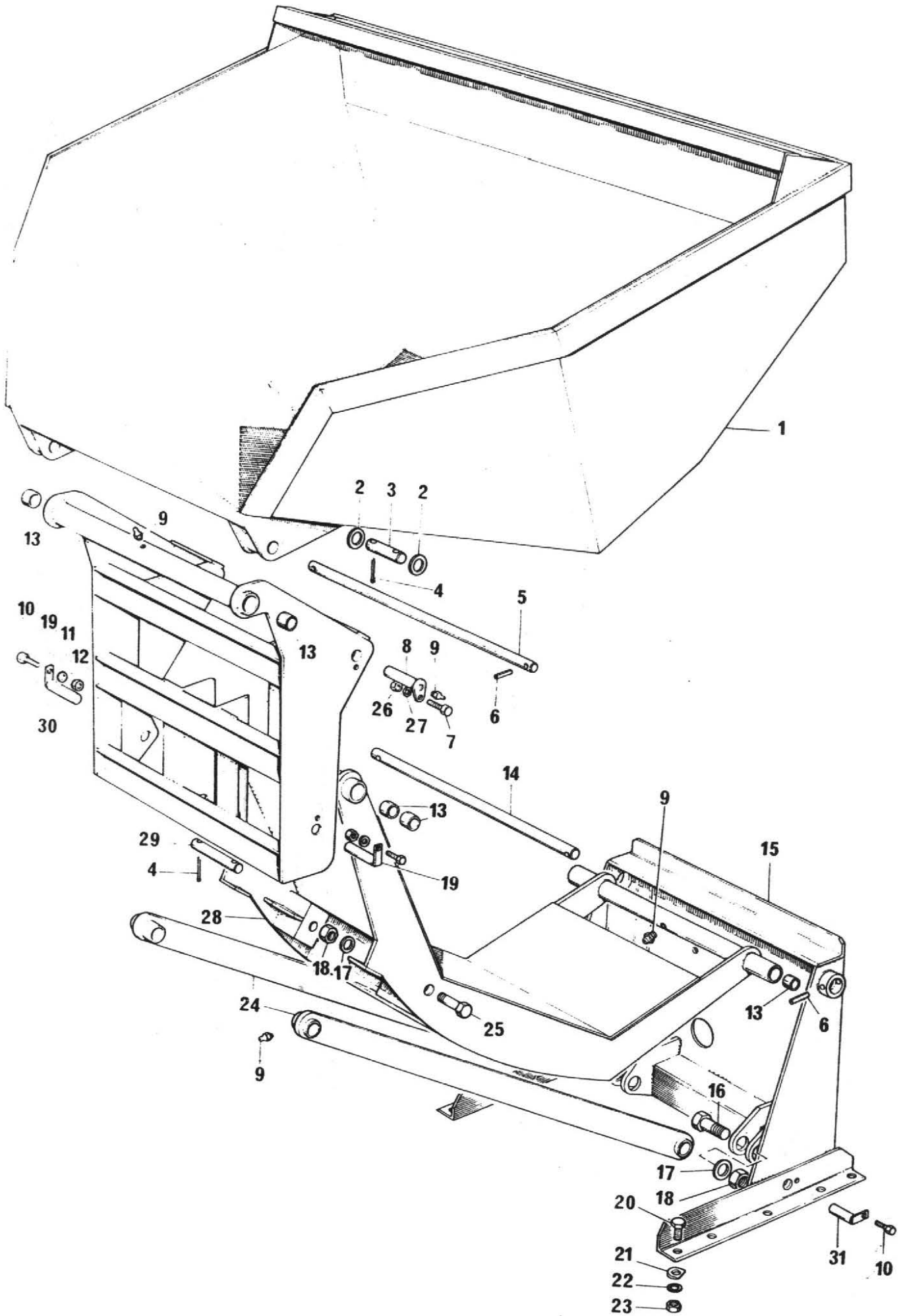

SKIP AND FRAME ASSEMBLY

<i>Item No.</i>	<i>Part No.</i>	<i>Description</i>	<i>No. Off</i>
1	4SHL.75	Skip	1
2		Flat Washer 1" Dia.	2
3	4SHL.65	Ram Pin	1
4		Split Pin 3/16" Dia. x 1.1/2"	2
5	4SHL.62	Skip Pivot Pin	1
6	4-35-29A	Tension Pin 5/16" Dia. x 2.1/4"	4
7		5/16" UNF Bolt x 1" Long	2
8	4SHL.61	Pin Lift Arm	2
9	5ST.100	Grease Nipple	8
10		Hex. Bolt 1/4" UNF x 1" Long	4
11		Spring Washer 1/4" Dia.	4
12		Hex. Nut 1/4" UNF	2
13	4SHL.91	Bush	8
14	4SHL.63	Pin - Lift Arm	1
15	4SHL.69	Rear Frame	1
16	4-35-110A	Ram Bolt	2
17		Spring Washer 1.1/4" Dia.	4
18	4-35-110B	Hex. Nut	4
19	4SHL.60	Link Pin - Front Frame	2
20		Hex. Bolt 1/2" UNF x 1.1/4" Long	10
21		Tapered Washer 1/2" Dia.	10
22		Spring Washer 1/2" Dia.	10
23		Hex. Nut 1/2" UNF	10
24	4SHL.56	Link	2
25	4SHL.64	Bolt	2
26		Hex. Nut 5/16" UNF	2
27		Spring Washer 5/16" Dia.	2
28	4SHL.72	Skip Lifting Frame	1
29	4SHL.66	Ram Pin	1
30	4SHL.68	Front Frame	1
31	4SHL.79	Link Pin - Fixed Frame	2

FLYWHEEL AND CLUTCH ASSEMBLY

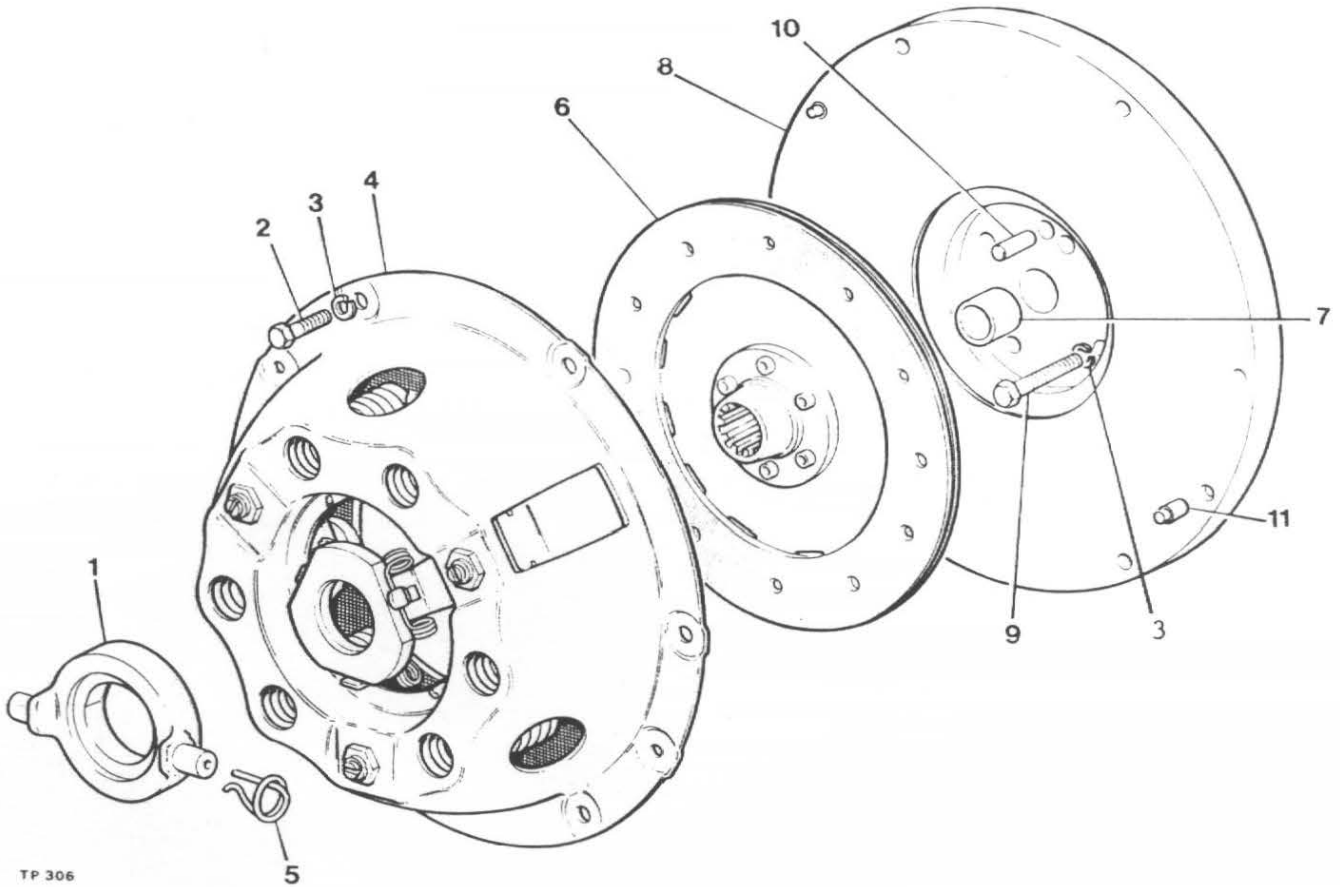

TP 306

Item No.	Part No.	Description	Qty.
1	10579A01	Clutch Release Bearing	1
2	28S02D	Screw Set	6
3	41S04	Washer Spring	10
4	10597A01	Cover Assembly	1
5	10579A101	Retainer Spring	2
6	10598A02	Drive Plate	1
7	10580A0101	Bush	1
8	10580A02	Flywheel Assembly (comprises of items 7, 8, & 11)	1
9	1S02C	Bolt, Petter PH Engine (drill for locking wire)	4
9A	6S02B	Bolt, Lister Engine (drill for locking wire)	4
10	C321	Dowel	1
11	10580A0102	Dowel	2
	10948A02	Clutch Kit (comprises of items 1, 4, 5 & 6)	1

It is recommended that instead of drilling the head of the bolts (item 9) for locking wire that one of each of tabwashers part no's 10531A02 and 10531A03 are used to prevent the bolts working loose.

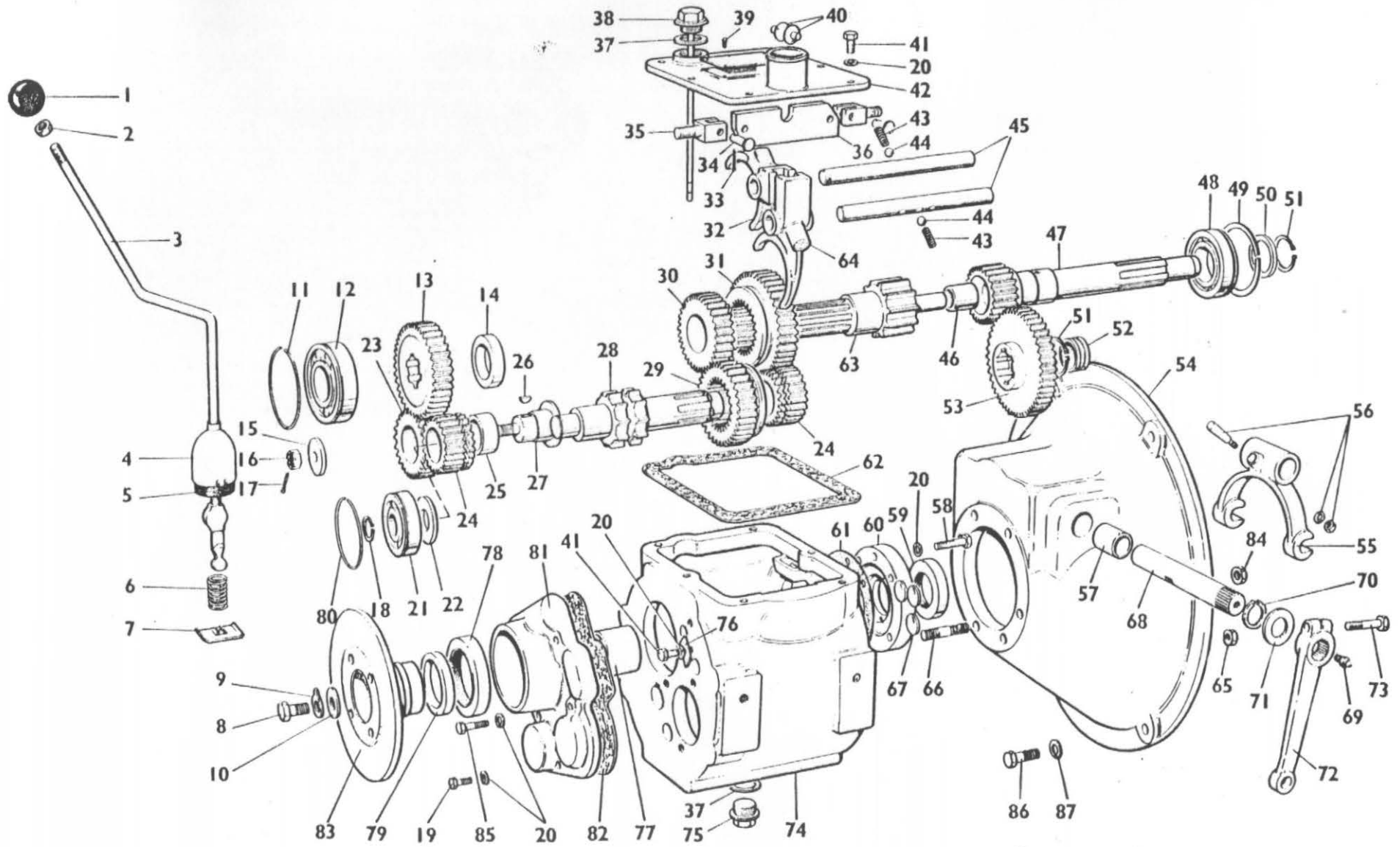

GEARBOX (40M-2-589 372)

Item No.	Part No.	Description	Qty.
1	40M-133	Gear Lever Knob	1
2	UN512	Gear Lever Locknut	1
3	40M-372	Gear Lever	1
4	40M-377	Gear Lever Cap	1
5	40M-129	Gear Lever Cover	1
6	40M-367	Gear Lever Spring	1
7	40M-245	Gear Lever Retaining Plate	1
8	USF 55	Bolt	1
9	CM2050	Tab Washer	1
10	CM2123	Washer	1
11	CM2060	Snap Ring	1
12	CM2052	Bearing, Mainshaft Rear	1
13	40M-110	Output Gear	1
14	40M-128	Output Gear Spacer	1
15	40M-155	Reverse Pinion Shaft Washer	1
16	UN507	Reverse Spindle Nut	1
17	CP1004	Split Pin	1
18	40M-148	Circlip	1
19	USF 31	Bolt	3
20	W104	Spring Washer	17
21	40M-146	Layshaft bearing	1
22	40M-130	Bearing spacer	1
23	40M-111	Reverse pinion	1
24	40M-114	Reverse speed gear	2
25	40M-161	Reverse pinion bush	1
26	40M-222	Reverse pinion shaft key	1
27	40M-119	Reverse pinion shaft	1
28	40M-118	Layshaft	1
29	40M-116	2nd. Speed sliding gear	1
30	40M-113	Second speed gear	1
31	40M-115	1st Speed gear	1
32	40M-502	2nd. and 3rd. Selector fork	1
33	40M-244	Split pin, interlock	2
34	40M-232	Clevis pin, interlock	2
35	40M-231	Stud, interlock	2
36	40M-505	Interlock plate	1
37	CP-1068	Sealing washer	2
38	40M-153	Dipstick	1
39	CP 1003	Drive screw	4
40	40M-254	Gear lever pad	2
41	USF 21	Bolt	7
42	40M-220	Top cover	1
43	CM 2103	Detent spring	2
44	CM 1077	Detent ball	2
45	40M-135	Selector shaft	2
46	40M-513	Bearing, Primary shaft	1
47	40M-117	Primary shaft	1

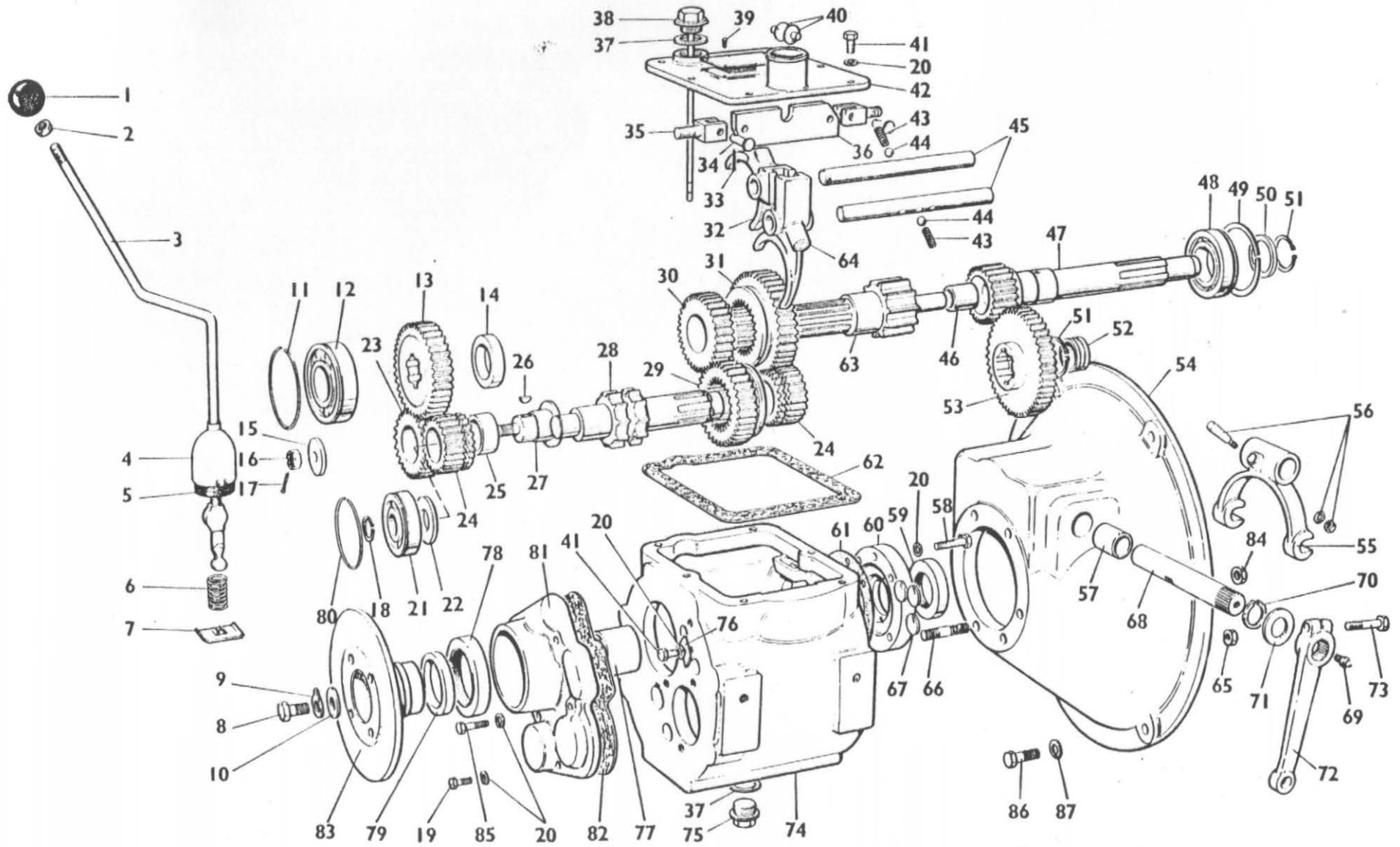

GEARBOX (CONT'D)

Item No.	Part No.	Description	Qty.
48	40M-143	Input bearing	1
49	40M-252	Snap ring	1
50	40M-174	Bearing spacer	1
51	CM2053	Circlip	2
52	40M-162	Layshaft bush	1
53	40M-360	1st. Reduction gear	1
54	40M-392	Clutch housing	1
55	CM2083	Clutch release fork	1
56	CM2084 S/A	Cotter, nut and washer S/A	1
57	CM2179	Cross shaft bush	2
58	UBF 71	Front cover bolt	4
59	40M-150	Oil seal, input	1
60	40M-126	Front cover	1
61	40M-172	Front cover gasket	1
62	40M-169	Top cover gasket	1
63	40M-514	Mainshaft	1
64	40M-501	1st. and reverse selector fork	1
65	UN501	Clutch lever nut	1
66	40M-177	Clutch housing stud	6
67	CM2113	Welch plug	3
68	40M-394	Clutch cross shaft	1
69	CP 1069	Grease nipple	2
70	CP 1006	Circlip	1
71	40M-398	Cross shaft washer	1
72	CM 2090	Clutch release lever	1
73	UBF 91	Clutch lever bolt	1
74	40M 101-B	Gearcase	1
75	CP 1189	Drain plug	1
76	40M-136	Selector locking strip	1
77	40M-138	Spacer	1
78	40M-167	Rear oil seal	1
79	CM 2537	Dust shield	1
80	40M-203	Snap ring	1
81	40M-107	Output cover	1
82	40M-171	Output cover gasket	1
83	CSE 164	Brake Disc (222mm dia)	1
84	UN516	Nut (Clutch housing)	6
85	USF 51	Bolt	2
86		Bolt 3/8" BSF x 1" long	6
87		Springwasher 3/8" dia.	6

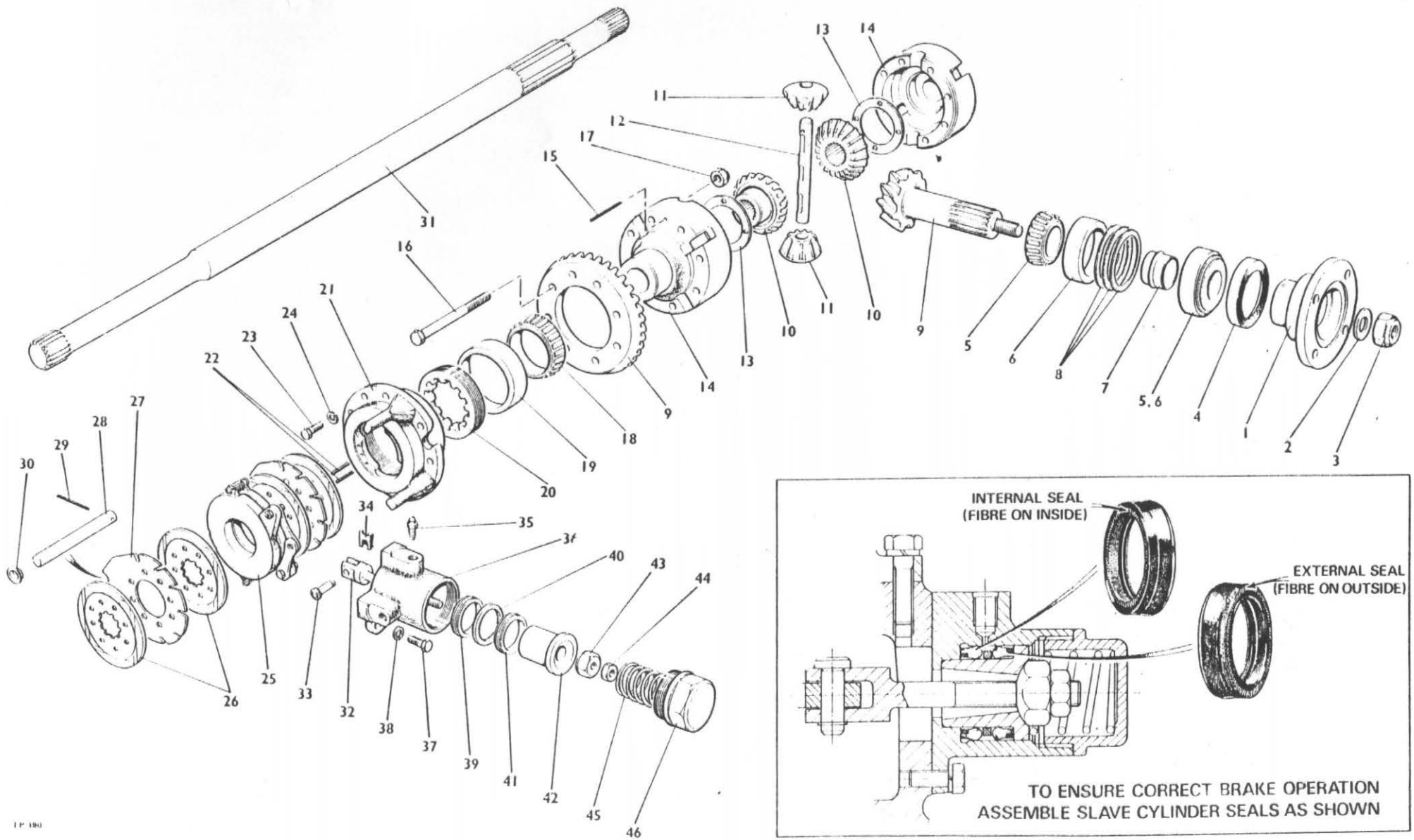

DRIVE AXLE

DIFFERENTIAL, HALF-SHAFTS & BRAKE ASSEMBLY

Item No.	Part No.	Description	Qty.
1	630130330	Coupling flange	1
2	630189112	Coupling flange washer	1
3	748415103	Coupling flange nut	1
4	742736074	Coupling flange oil seal	1
5	660101110	Bevel pinion bearing cone	2
6	660101128	Bevel pinion bearing cup	2
7	630075741	Bevel pinion bearing cone spacer	1
8	630041503	Bevel pinion bearing shim .05mm (.002")	A.R.
	630041511	Bevel pinion bearing shim .13mm (.005")	A.R.
	630041529	Bevel pinion bearing shim .25mm (.010")	A.R.
9	630127732	Bevel pinion	1
	630128730	Bevel wheel	1
10	630124101	Differential bevel wheel	2
11	630125058	Differential pinion	2
12	630126114	Differential trunnion	1
13	630031173	Differential bevel wheel thrust washer	2
14	630123350	Differential cage (recessed)	1
	630123368	Differential cage (bossed)	1
15	660170206	Roll pin	1
16	748230825	Differential cage bolt	8
17	748415061	Differential cage bolt nut	8
18	660100237	Differential bearing cone	2
19	660100245	Differential bearing cup	2
20	630033351	Differential bearing nut	2
21	630143184	Differential bearing housing	2
22	660390010	Roll pin	4
23	748211015	Differential bearing housing setscrews	16
24	660240116	Differential bearing housing setscrew spring washer	16
25	660020765	Actuator)	2
26	660020781	Middle plate) Supplied as an Assembly - 680600281	8
27	660020773	Intermediate plate)	4
28	630096358	Torque pin	2
29	660170214	Retaining pin	2
30	630036636	Torque pin cover	2
31	630045728	Drive shaft	2
32	630066138	Brake pull rod	2
33	630096291	Brake link pin	2
34	660060258	Brake link pin circlip	2
35	660500055	Brake cylinder bleed valve	2
36	630062244	Brake cylinder	2
37	748210777	Brake cylinder setscrew	4
38	660240108	Brake cylinder setscrew spring washer	4
39	660300167	Brake piston seal (Internal)	2
40	630075774	Spacer	2
41	660300159	Brake piston seal (External)	2
42	630064190	Brake piston	2
43	630183255	Brake pull rod nut	2
44	748440077	Brake pull rod locknut	2
45	630069066	Brake piston spring	2
46	630036552	Brake cylinder cap	2
47	693300846	Drive Axle complete (not illustrated)	1

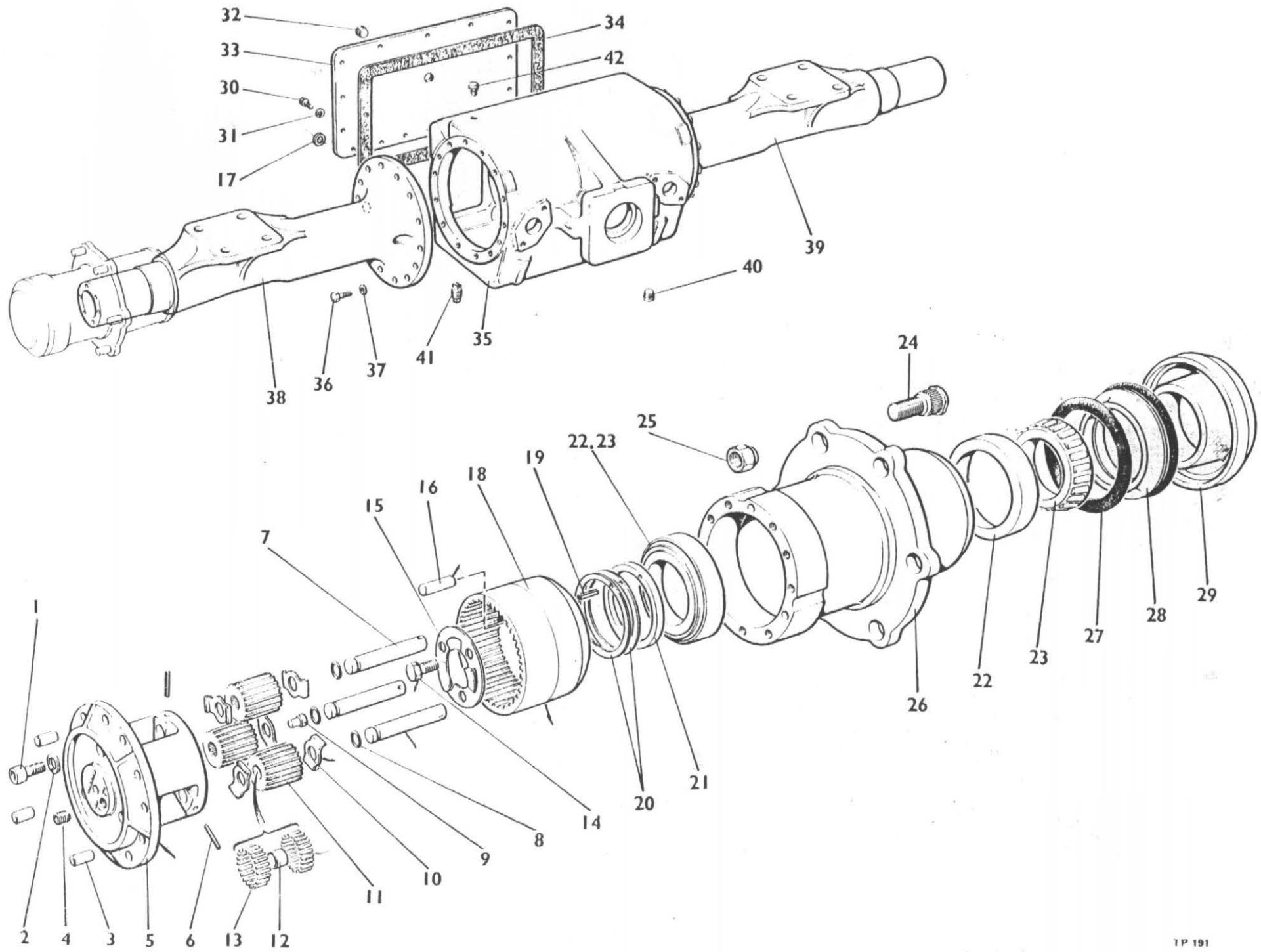

DRIVE AXLE

CASING & HUB ASSEMBLY

Item No.	Part No.	Description	Qty.
1	748011068	Planet Carrier Capscrew	18
2	740773053	Planet Carrier Capscrew Spring Washer	18
3	740100679	Planet Carrier Dowel	6
4	742223016	Planet Carrier Plug (1/8" B.S.P.T.)	2
5	630029565	Planet Carrier	2
6	660390010	Planet Pin Retaining Pin	6
7	630030258	Planet Pin	6
8	742010082	Planet Pin "O" Ring	6
9	660420015	Planet Carrier Thrust Button	2
10	630031413	Planet Wheel Side Washer	12
11	630027247	Planet Wheel	6
12	630075873	Planet Wheel Needle Roller Spacer	6
13	660200185	Planet Wheel Needle Rollers	240
14	630180509	Annulus Setscrew	6
15	630023386	Retaining Plate	2
16	630048128	Dowel	6
17	742171033	Washer	7
18	630026439	Annulus	2
19	660170180	Bearing Spacer Pin	2
20	630041701	Shim Pack	A/R
21	630075550	Bearing Spacer	2
22	660101185	Hub Bearing Cup	2
23	660101193	Hub Bearing Cone	2
24	630020127	Wheel Stud	12
25	630021075	Wheel Nut	12
26	630017719	Hub	2
27	660310174	"O" Ring (Spares Only)	4
28	660300233	Hub Oil Seal	2
29	630016430	Distance Piece	2
30	748210751	Casing Cover Setscrew	16
31	660240108	Casing Cover Setscrew Springwasher	9
32	742222034	Filler/Lever Plug (As Item 40)	1
33	630036479	Axle Casing Rear Cover	1
34	630037378	Rear Cover Gasket	1
35	630001580	Axle Centre Casing	1
36	748230700	Mounting Arm Bolt	28
37	660240116	Mounting Arm Bolt Spring Washer	28
38	630006381	Mounting Arm - Left Hand	1
39	630006373	Mounting Arm - Right Hand	1
40	742222034	Plug - 1/2" B.S.P.T. (As Item 32)	1
41	660190097	Plug - Magnetic Drain	1
42	660500014	Breather	1
	680300478	Hub Assembly (comprising items 22, 24, 25 & 26)	
	680500143	Planet Carrier Assembly (comprising items 5-13 inclusive) ..	
	693300846	Drive Axle Complete (not illustrated)	1

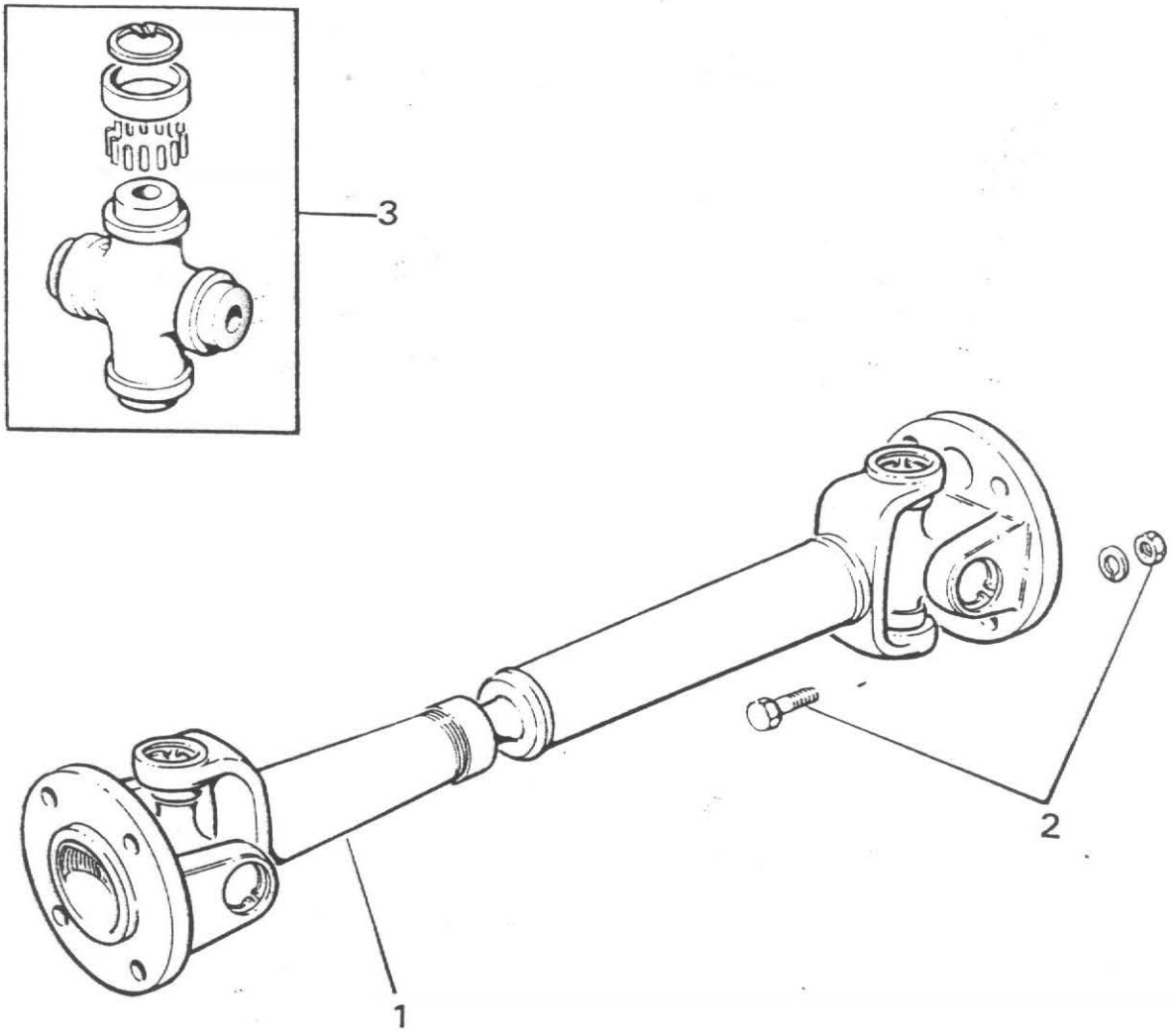

PROP SHAFT

Item No.	Part No.	Description	Qty
1	4SHL 110	Prop Shaft	1
2		Bolt 7/16"BSF x 1 1/4" long & Nut	8
3	10313A03	Repair Kit	A/R

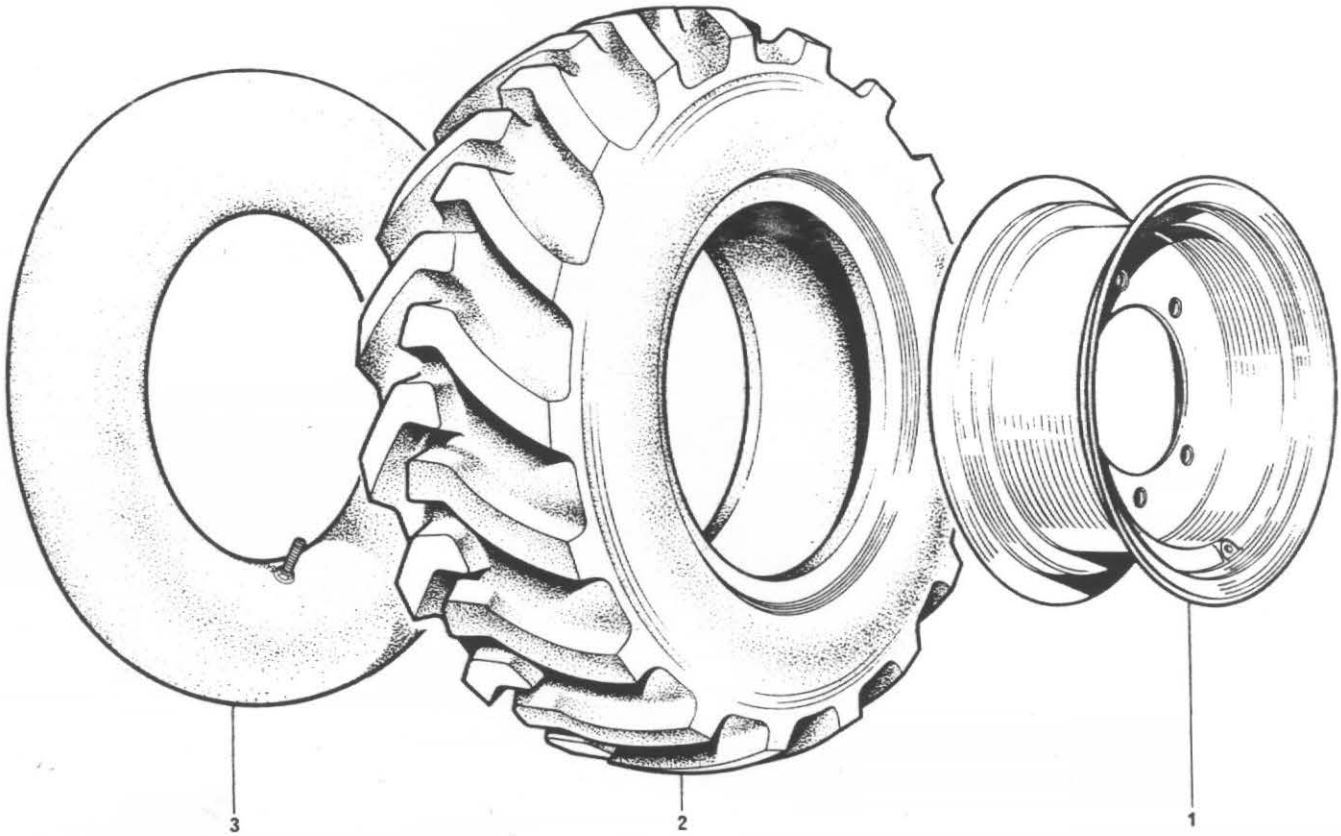

DRIVE WHEELS AND TYRES

Item No.	Part No.	Description	Qty.
	24S16	R/H Wheel Assembly	1
	24S15	L/H Wheel Assembly	1
1	30193A01	Wheel rim 9 x 18	2
2	20S01	Tyre 10.5 x 18-6 ply	2
3	23S04	Tube 10.5 x 18	2

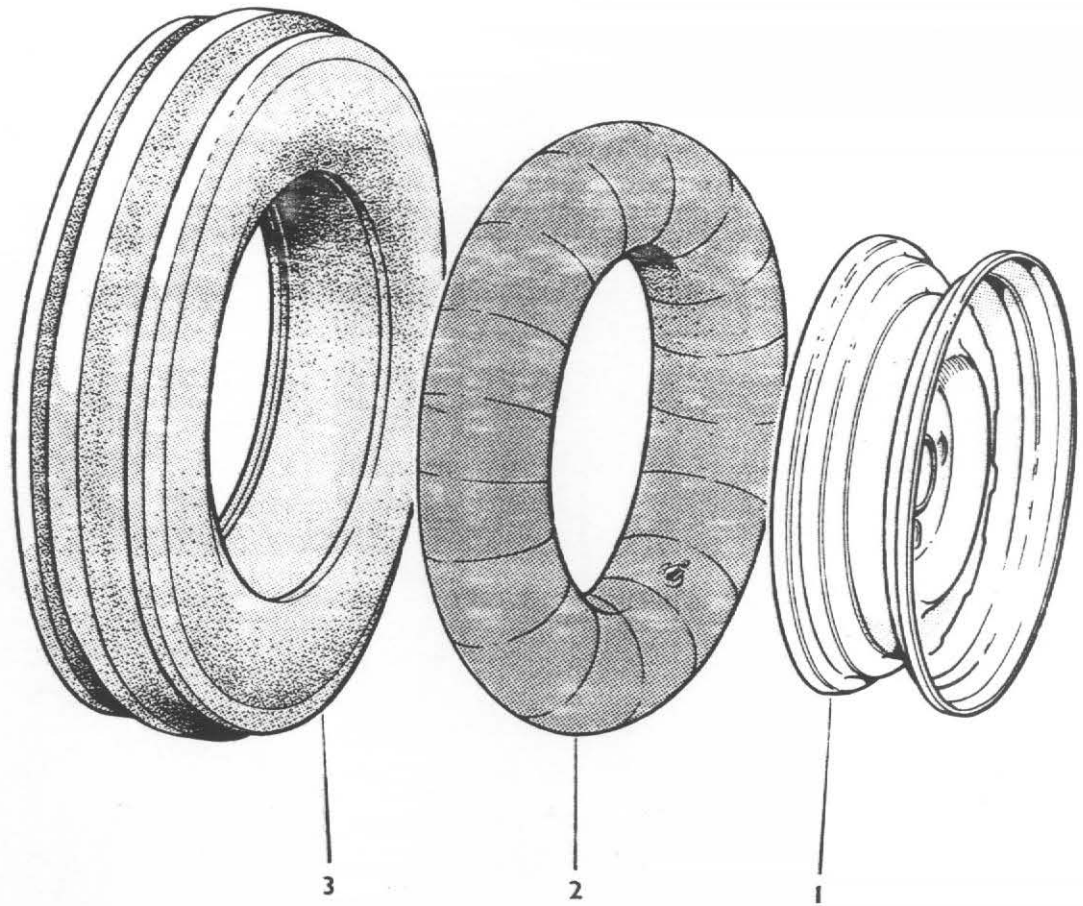

STEERING WHEELS AND TYRES

Item No.	Part No.	Description	Qty.
1	24S31	Steering wheel complete	2
2	30033A01	Wheel rim 4.00 x 16	2
2	23S02	Tube 6.00 x 16	2
3	21S03	Tyre 6.00 x 16-4 ply	2

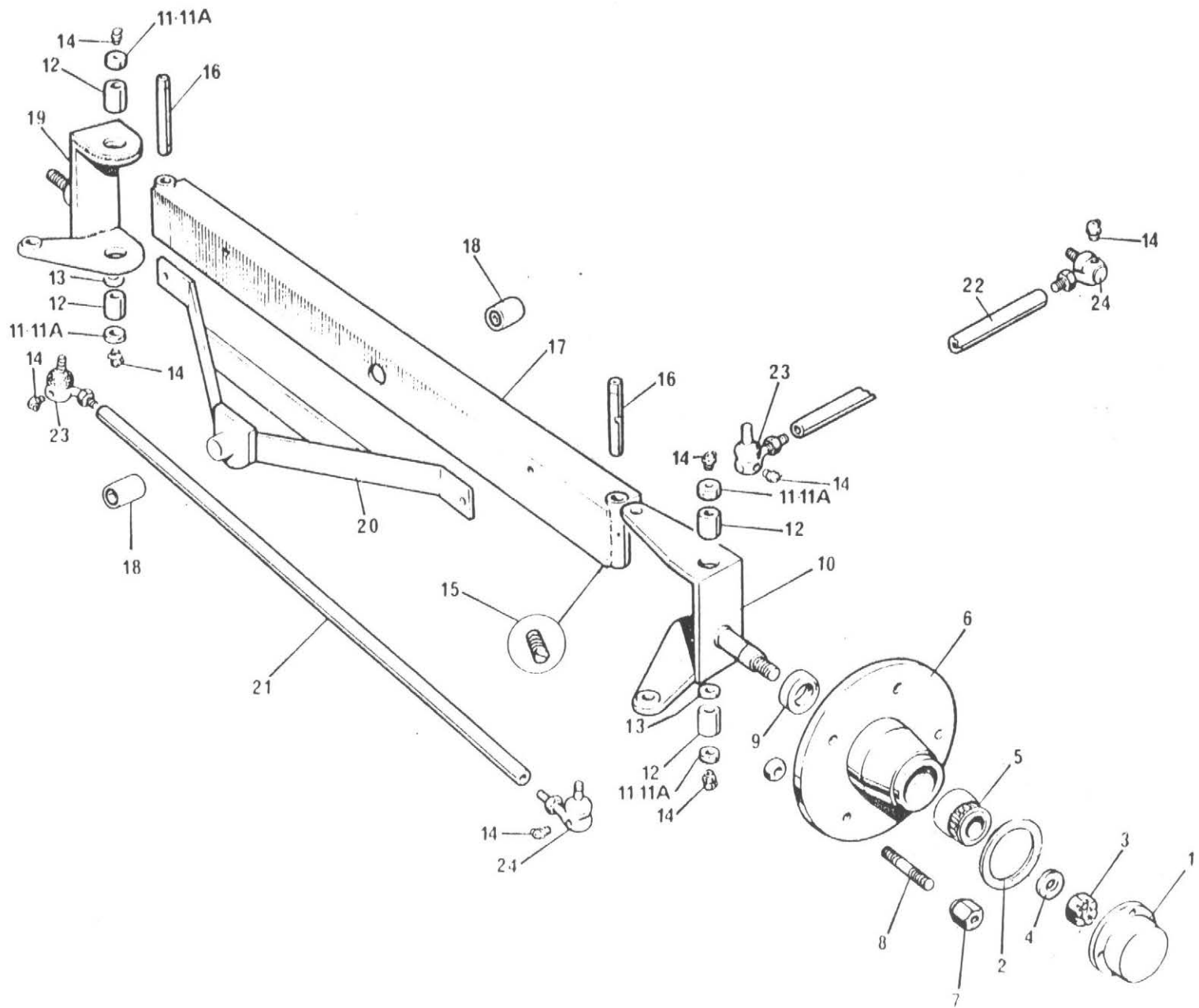

STEERING ASSEMBLY

<i>Item No.</i>	<i>Part No.</i>	<i>Description</i>	<i>No. Off</i>
1	R344	Hub Cap	2
2	R345	Gasket, Hub Cap	2
3	R305-A	Slotted Nut	2
4	4S.149	Washer	2
5	K18690-K18620	Bearing, Hub	4
6	0190	Hub Assembly, including items 1, 2, 5, 7, 8, 9	2
7	R340	Wheel Nut	10
8	0190-S	Wheel Stud C/W Lock Nut	10
9	R343	Oil Seal, Hub Bearing	2
10	F505-OS	Stub Axle Assembly R.H.	1
11	C180-A	Washer, King Pin (Felt)	4
11A	C180-B	Washer, King Pin (Steel)	4
12	C190	Bush, King Pin	4
13	C175	Thrust Washer	2
14	T90	Grease Nipple	8
15	C111-A	Screw, King Pin Retaining	2
16	R320	King Pin	2
17	F503	Steering Axle Beam	1
18	E2245	Bush, Steering Axle and Stabiliser	2
19	F505-NS	Stub Axle Assembly L.H.	1
20	L262	Steering Axle Stabiliser	1
21	F512	Track Rod	1
22	F513	Drag Link	1
23	C159/LH	Steering Ball Joint with Nut	2
24	C159/RH	Steering Ball Joint with Nut	2

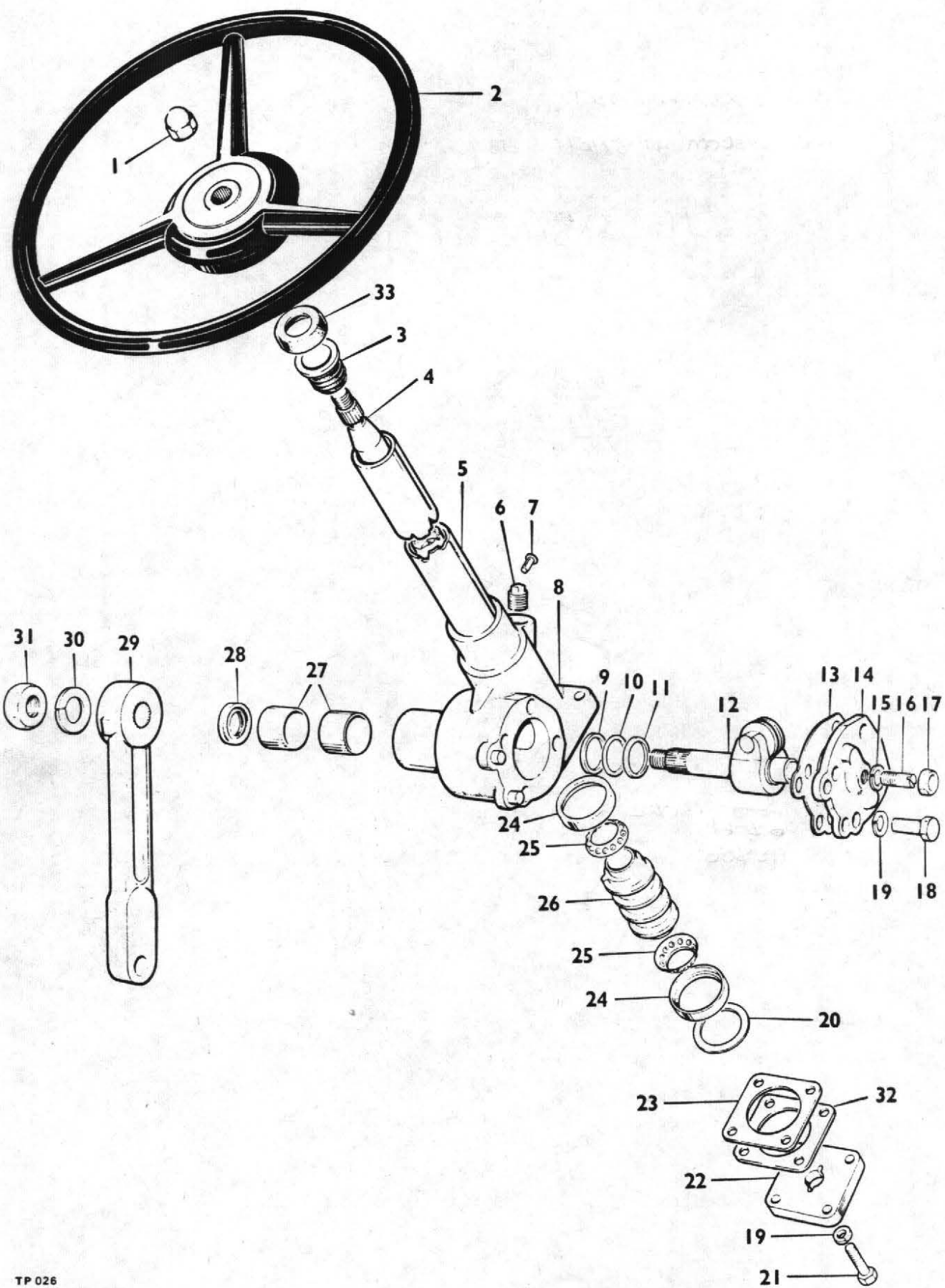

STEERING GEAR (CAM AND ROLLER TYPE)

Item No.	Part No.	Description	Qty.
	MGA 34849	Steering column assy. complete less items, 1,2 & 29	1
1	C 304	Steering wheel nut	1
2	347 K	Steering wheel	1
3	PA3904A	Column top bush	1
4	P5244/30"	Inner shaft	1
5	P3911/24"	Outer tube	1
6	S 9033	Oil plug	1
7	S 9166	Pin	1
8	PA4426	Steering box c/w item 14	1
9	P4151	Thrust washer	2
10	P 3308	Shim	A/R
11	P 4150	Thrust washer	2
12	PA5229/4¼"	Rocker shaft c/w roller	1
13	P3306A	Cover plate gasket	A/R
14	QA757	Cover plate and bush	1
15	S 999	Spring washer	1
16	P 4222	Adjuster screw	1
17	P 4221	Nut	1
18	S 9240	Setscrew	4
19	S 902	Spring washer	8
20	P3342	Washer	1
21	S 9300	Setscrew	4
22	P 3907	Bottom cap	1
23	P 3301/.005"	Shim	A/R
24	P 3341	Outer race	2
25	PA2733	Cage and balls	2
26	P 3340	Cam	1
27	P 3309	Bush	2
28	S 9242	Oil seal	1
29	M 29629	Drop arm	1
30	S 955	Spring washer	1
31	S 9332	Nut	1
32	P 3301G	Bottom cap liner	2
33	M33418	Inner column shroud	1

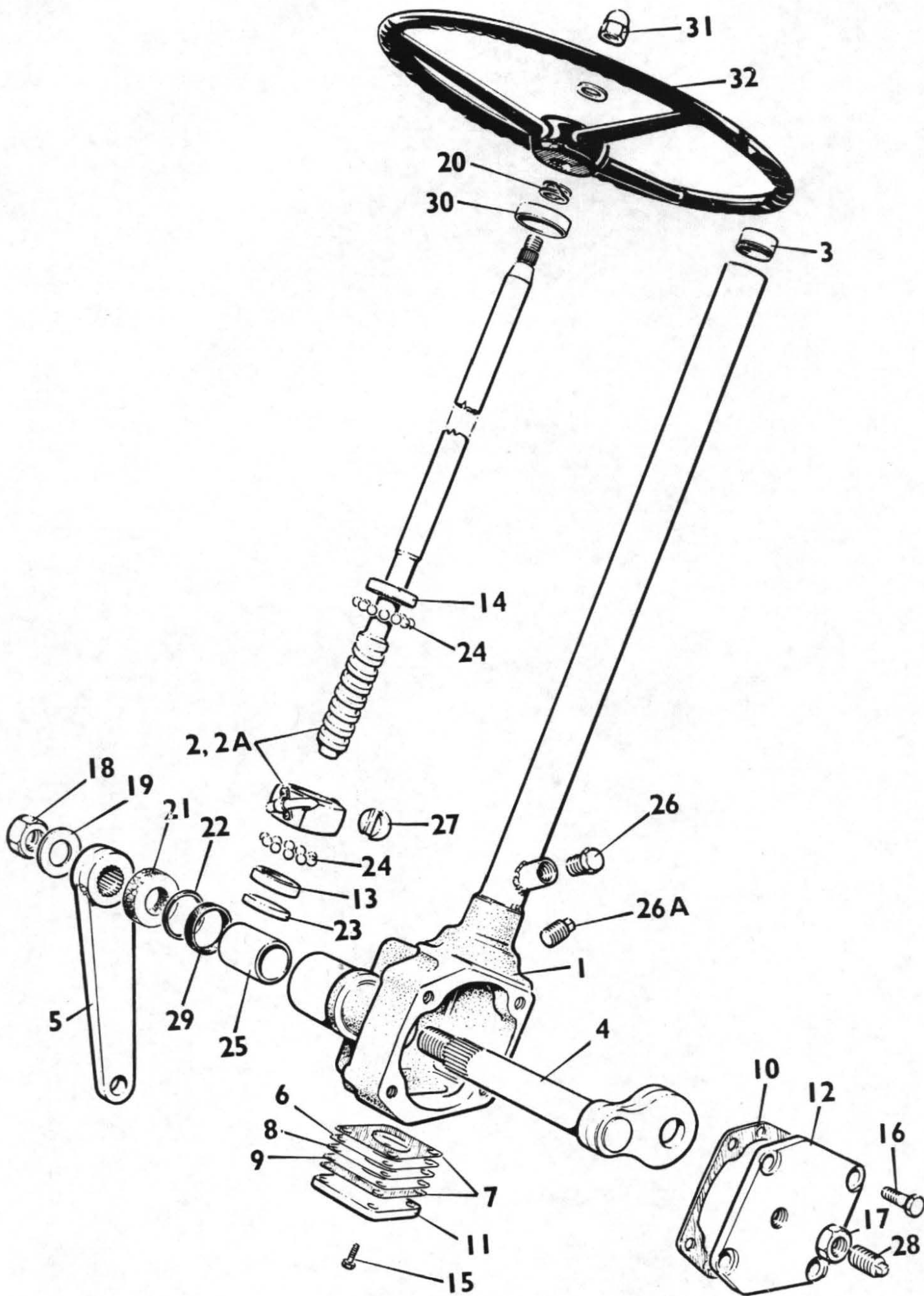

STEERING GEAR (RECIRCULATING BALL TYPE)

Item No	Part No.	Description	Qty
	11-077	Steering gear complete (less items 5 & 32)	
1	SA-01-183	Box and Tube assembly	1
2	SA-02-269	Inner column assembly and main nut (700mm long)	1
2A	SA-02-277	Inner column assembly and main nut (750mm long)	1
3	SA-21-004	Bearing assembly	1
4	S-7-103	Rocker shaft	1
5	2SE90	Drop arm	1
6	S-10-14	End plate shim .005"	3
7	S-10-15	End plate gasket	2
8	S-10-42	End plate shim .002"	2
9	S-10-111	End plate shim .010"	2
10	S-10-191	Cover plate gasket	1
11	S-11-83	End plate	1
12	S-12-186	Cover plate	1
13	S-23-32	Ballrace (small)	1
14	S-23-33	Ballrace (large)	1
15	10-3-37	End Plate bolt	4
16	10-4-16	Cover Plate bolt	4
17	11-7-2	Rocker shaft adjuster screw nut	1
18	11-8-7	Rocker shaft nut	1
19	12-8-36	Rocker shaft tab washer	1
20	12-8-85	Spring	1
21	12-9-61	Drop arm felt washer	1
22	12-10-7	Oil seal retaining washer	1
23	12-12-26	Inner column packing plate	1
24	17-3-4	Steel ball	54
25	19-9-17	Rocker shaft bush	1
26	21-8-4	Oil Plug	1
26A	21-7-2	Oil Plug	1
27	24-5-5	Main nut roller	1
28	25-7-2	Rocker shaft adjuster screw	1
29	27-9-6	Oil seal	1
30	32-8-8	Dust cap	1
31	11-7-45	Dome nut	1
32	347K	Steering wheel	1

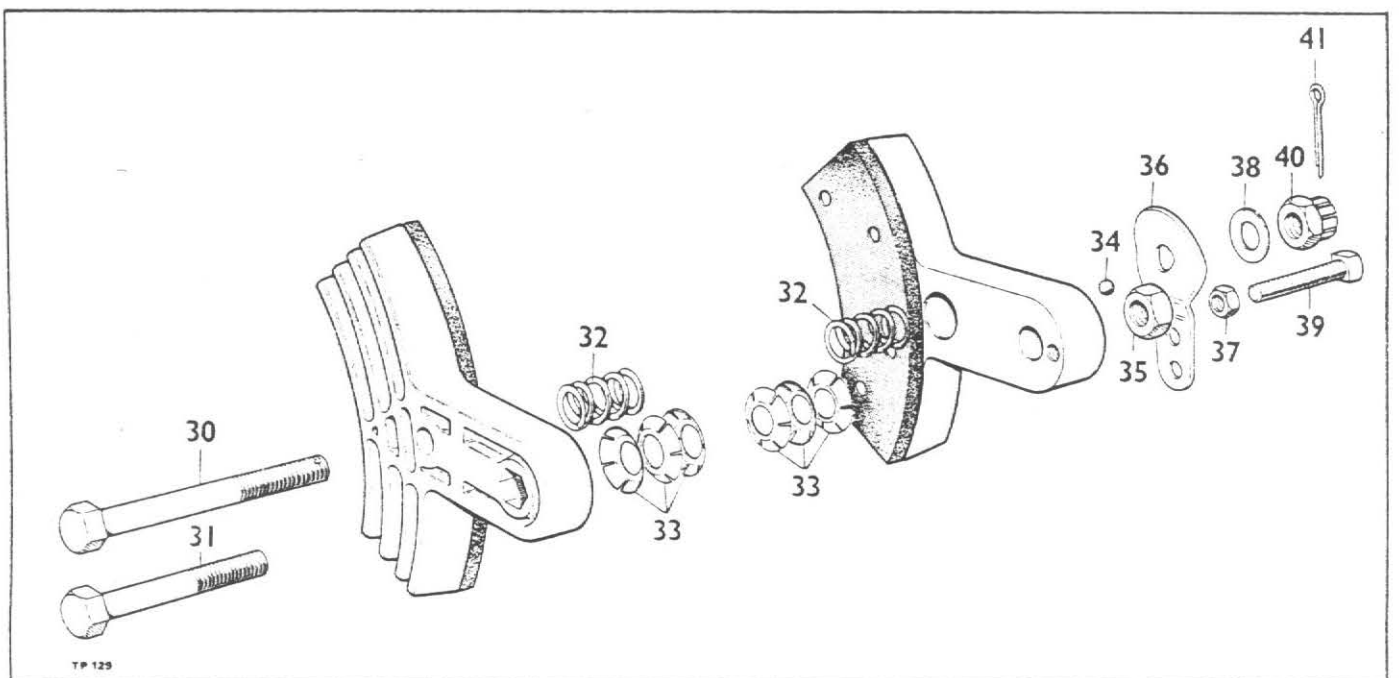
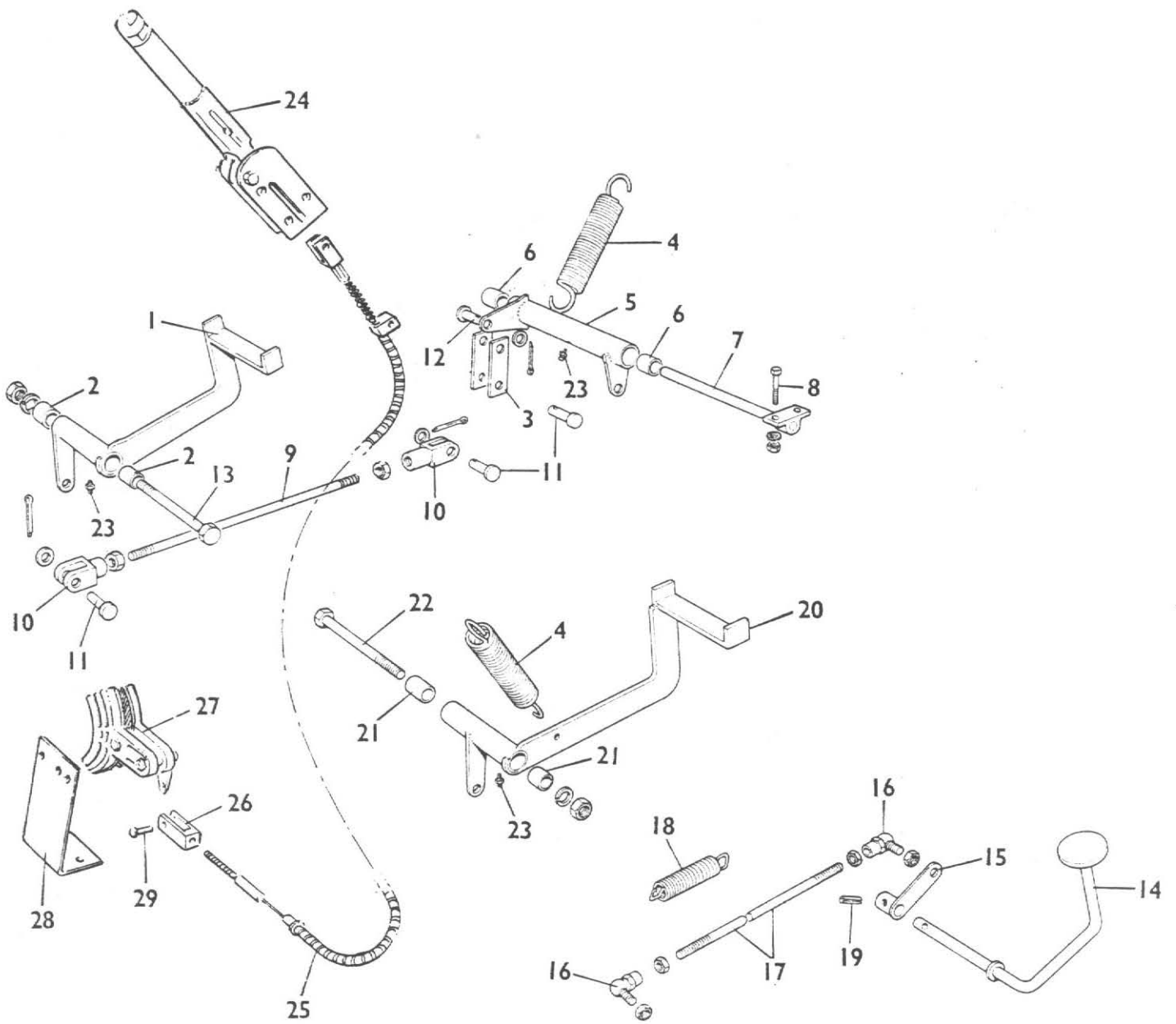

PEDALS, CONTROLS & HANDBRAKE ASSEMBLY

Item No.	Part No.	Description	Qty
1	F521	Pedal, Clutch	1
2	WB.1010	Bush, Clutch Pedal	2
3	F537	Link, Clutch Lever	2
4	C173-B	Spring, Return (Clutch and Footbrake Pedal)	2
5	F519	Lever, Clutch Transfer	1
6	WB.0808	Bush, Transfer Lever	2
7	F519A	Rod, Clutch Transfer Lever	1
8		Nut and Bolt 3/8" BSF x 1.1/4" Long	1
9	F525	Rod, Clutch Adjusting 14. 1/2" x 3/8" BSF	1
10	C.174A	Clevis	2
11	C.174X	Clevis Pin	3
12	5ST - 101	Clevis Pin	1
13		Nut and Bolt, 5/8" BSF x 4. 1/2" Long	1
14	C.137	Pedal, Accelerator	1
15	F522	Lever, Accelerator	1
16	C160-B	Ball End, Accelerator Rod	2
17	F524	Rod, Accelerator	1
18	C.173-D	Spring, Return (Accelerator Rod)	1
19	C.129A	Pin, Tension	1
20	4S. 102	Pedal, Footbrake	1
21	WB.1212	Bush, Footbrake Pedal	2
22		Nut and Bolt 3/4" BSF x 8" Long	1
23	T/ST	Nipple, Grease (Straight)	3
24	715-C-11605	Handbrake Lever	1
25	4-35-44 (Modified)	Handbrake Cable	1
26	4SHL113	Clevis	1
27	1073-A1	Handbrake Caliper (complete)	1
28	4SHL 107	Caliper Bracket	1
29	4-35-264	Clevis Pin	1
30	1-1116	Screw 5/26" UNF x 3 1/2" long	1
31	1-1398	Screw 5/16" UNF x 2 1/2" long	1
32	6-1009	Centring Spring	2
33	3-1013	Tension Washer (Spring Alternative - Qty 2)	6
34	1132	Ball Bearing	2
35	2-1014	Nut 5/16" UNF	1
36	1004-1	Cam	1
37	2-1015	Jam Nut 1/4" UNC	1
38	3-1030	Washer 5/16" ID. x 1" OD	1
39	1-1022	Setscrew 1/4" UNC x 1 1/2" long	1
40	2-1011	Castle Nut 5/16" UNF	1
41	5-1012	Cotter Pin	1

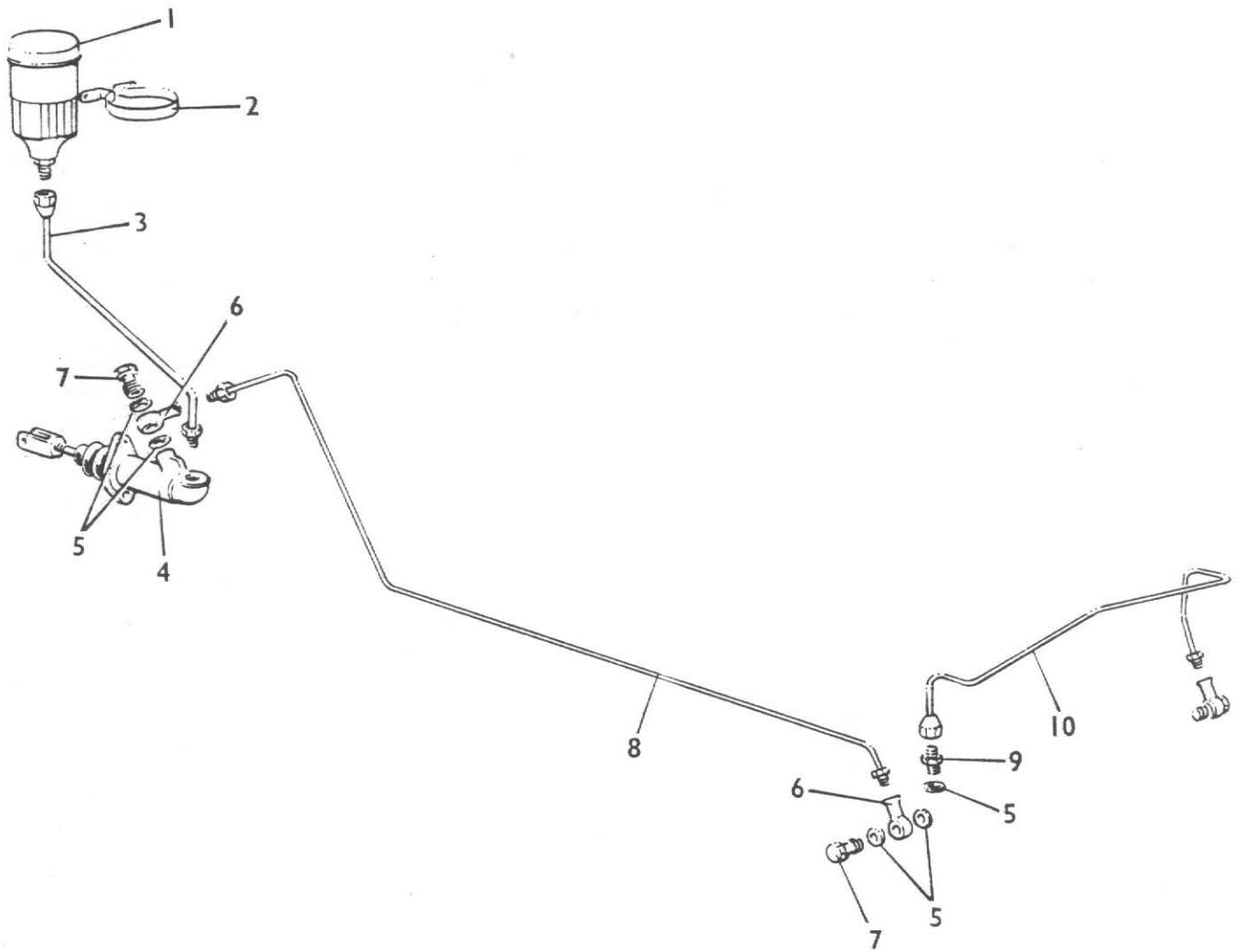

BRAKE PIPES & FITTINGS

Item No.	Part No.	Description	Qty.
1	64046158	Header Tank	1
2	64477544	Clip	1
3	DM 89-1	Pipe 1/4" dia x 21" long	1
4	64066004	Master Cylinder (See Page 31)	1
5	678700	Washer	7
6	64474287	Banjo	3
7	64473063	Banjo Bolt	3
8	DM 78-4	Pipe 3/16" dia x 53" long	1
9	64473623	Adaptor 3/8" UNF x 7/16" UNF	1
10	DM 79-2	Pipe 3/16" dia. x 19" long	1

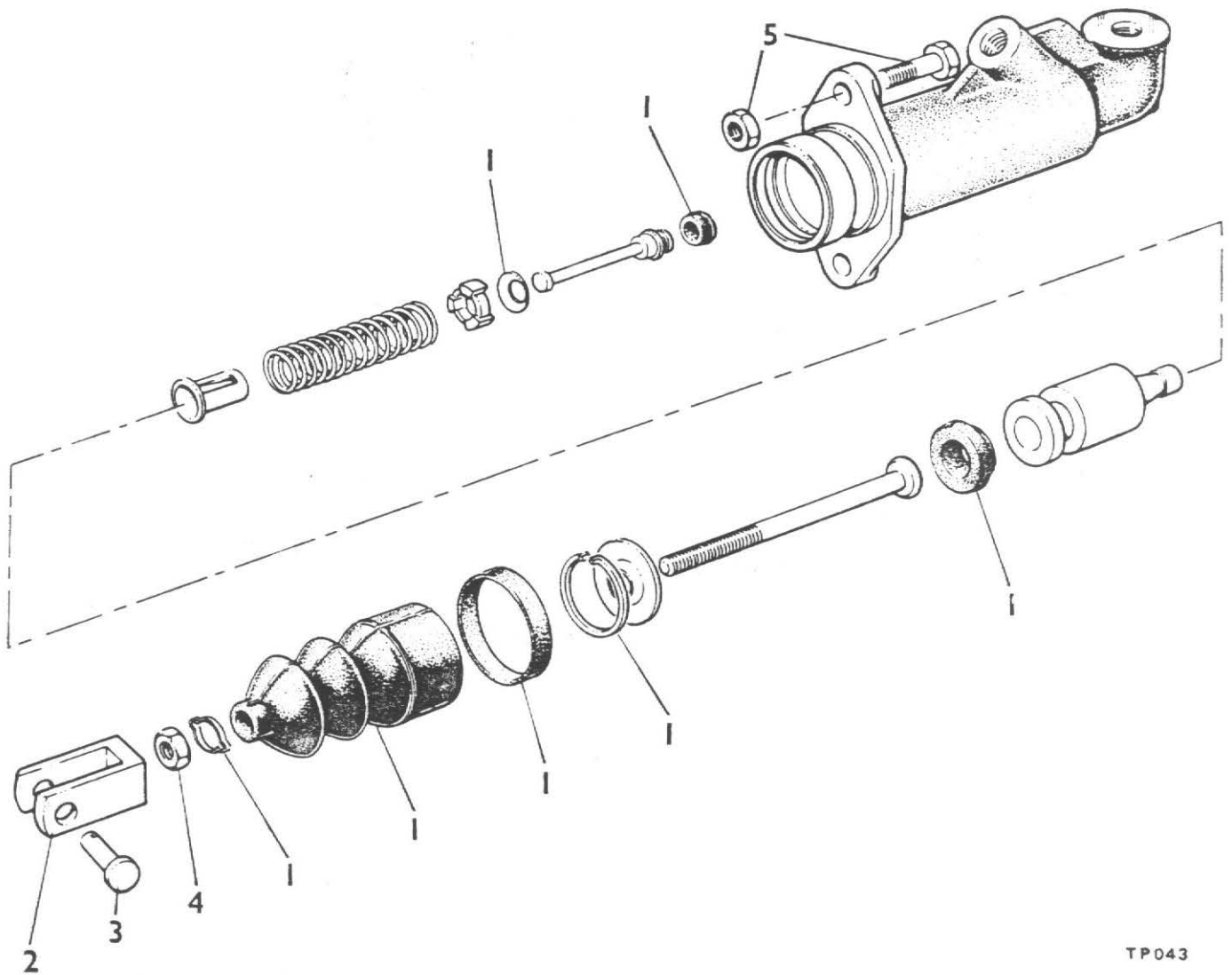

TP043

BRAKE MASTER CYLINDER ASSEMBLY

Item No.	Part No.	Description	Qty.
	64066004	Master Cylinder Complete	1
1	SP.2636	Service Kit	A/R
2	64671286	Clevis	1
3	C174Y	Clevis Pin	1
4	64100052	Locknut	1
5		Boit M10 x 40mm long & locknut	2

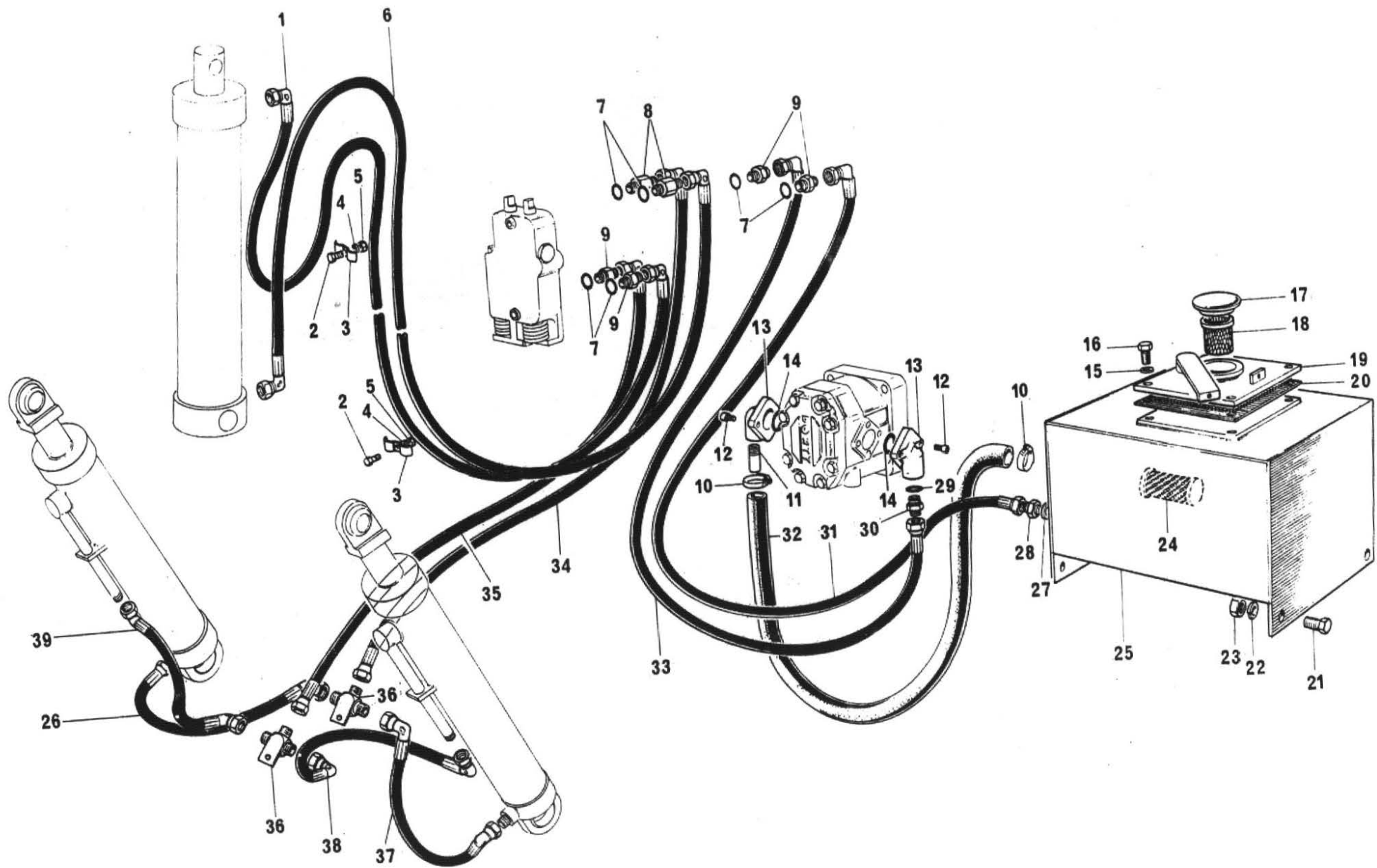

HYDRAULICS

<i>Item No.</i>	<i>Part No.</i>	<i>Description</i>	<i>No. Off</i>
1	4SHI 87	Hose - Valve to Ram Head 3/8" x 100" x 90°/90°	1
2		Bolt 1/4" UNF x 1" Long	2
3	X81	Pipe Clamp	2
4		Washer (Spring) 1/4" Dia.	2
5		Nut 1/4" UNF	2
6	4SHL 86	Hose - Valve to Ram Base 3/8" x 98" x 90°/90°	1
7	S9697	'O' Ring - Seal	6
8	4-60-158	3/8" BSP x 7/8" J.I.C. Adaptor - Long	2
9	CSE 186	3/8" BSP x 7/8" UNF Adaptor - Short	4
10	T-63-M	Clip	2
11	T48	Tube	1
12		Capscrews 5/16" UNF x 1.1/4" Long	4
13	GP-2-A2	Adaptor	2
14	DH-25-19	'O' Ring - Seal	2
15		Spring Washer 5/16" Dia.	4
16		Hex. Head Bolt 5/16" UNF x 3/4" Long	4
17	P2578-2	Cap	1
18	P1145	Strainer	1
19	4/35-187	Cover Plate Assembly	1
20	T-18-B	Gasket	1
21		Hex. Head Bolt 3/8" UNF x 1" Long	4
22		Spring Washer 3/8" Dia.	4
23		Nut 3/8" UNF	4
24	UC-1457	Filter	1
25	2ST118	Hydraulic Tank	1
26	4SHL 94	Hose L.H. Tee - R.H. Ram Base 3/8" x 39" x ST/90°	1
27	T-14-I	3/8" Sealing Washer	1
28	T-14-J	3/8" x 3/8" Parallel Adaptor	1
29	T-14-H	1/2" Sealing Washer	1
30	T-63-K	3/8" x 1/2" BSP Adaptor	1
31	4SHL 82	Hose - Valve to Tank 3/8" x 43" x ST/90°	1
32		3/4" Bore - Cotton Braid Hose - 48" Long	1
33	4-60-139	Hose - Pump to Valve 3/8" x 37" x 90°/135°	1
34	3SH 63	Hose - Valve to L.H. Tee 3/8" x 23.1/2" x ST/90°	1
35	4SHL 95	Hose - Valve to R.H. Tee 3/8" x 13" x 90°/90°	1
36	4SHL 97	Tee Bracket	2
37	4SHL 96	Hose - L.H. Tee to L.H. Ram Base 3/8" x 17" x 90°/90°	1
38	4/60/133	Hose R.H. Tee to L.H. Ram Head 3/8" x 48" x ST/90°	1
39	4SHL 93	Hose R.H. Tee to R.H. Ram Head 3/8" x 21.1/2" x ST/ST	1

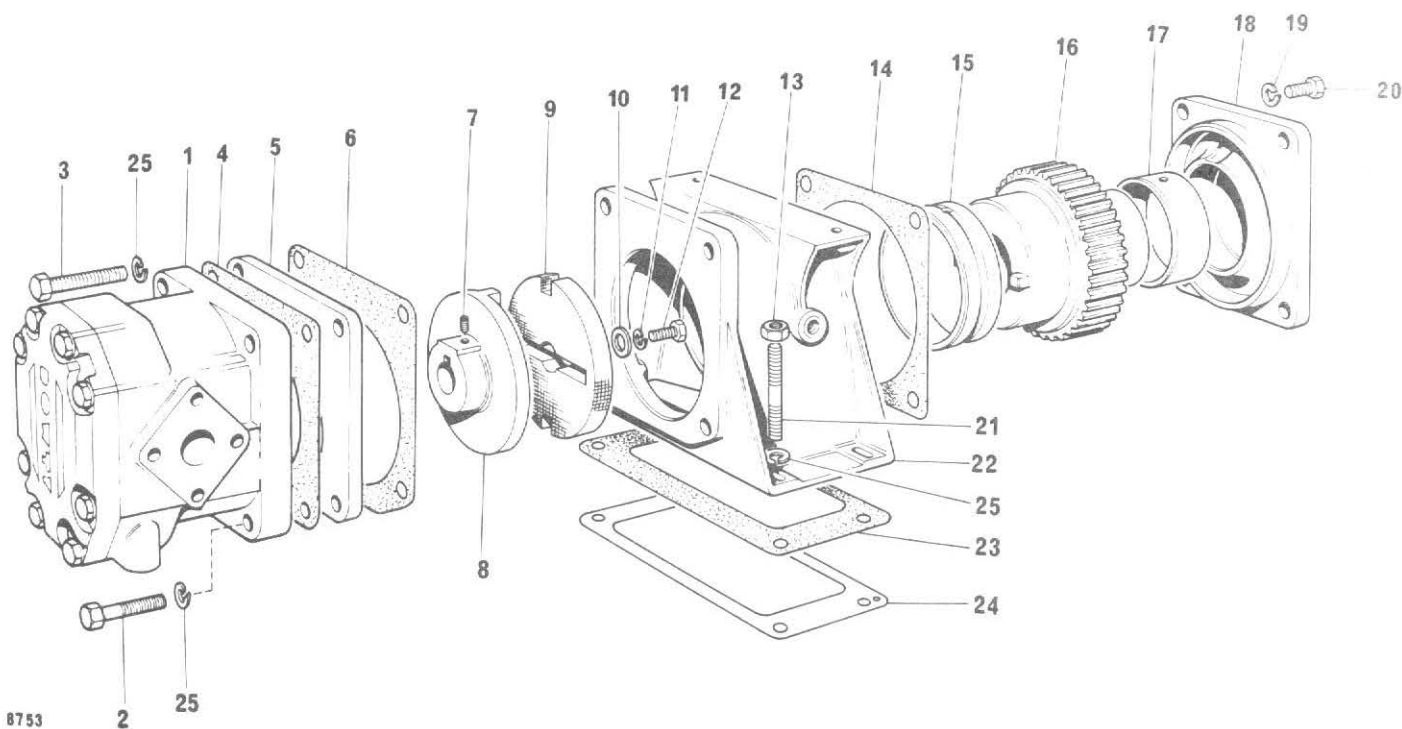

HYDRAULIC PUMP AND DRIVE GEAR

Item No.	Part No.	Description	No. Off.
1	GP265CU	Pump	1
2	NSD110 x 3/8" x 2"	Bolt 3/8" UNF x 2" Long	2
3	NSD110 x 3/8" x 2.1/2"	Bolt 3/8" UNF x 2.1/2" Long	2
4	263871	Joint	1
5	266158	Plate, Spigot	1
6	266159	Joint	1
7	NSD840	Screw, Socket 1/4" x 3/4" Long	1
8	266156	Coupling, Pump	1
9	265413	Block, Coupling	1
10	264705	Washer, Plain	1
11	NSD137 x 1/4"	Washer, Spring x 1/4"	1
12	NSD1004	Set Screw, Pump Shaft 1/4" UNF x 1/2" Long	1
13	NSD20 x 3/8"	Nut 3/8"	4
14	264702	Joint	1
15	2-264704	Bearing Housing	1
16	2-264703	Gearwheel	1
17	2-202485	Bush, Housing	1
18	264701	Cover, Pump Housing	1
19	NSD137 x 5/16"	Washer, Spring x 5/16"	4
20	NSD111	Setscrew, 5/16" x 5/8" Long	4
21	NSD60	Stud 3/8" x 1.1/2"	4
22	2-197597	Housing, Pump	1
23	264700	Joint	1
24	264706	Shim	A/R
25	NSD137	Washer, Spring x 3/8"	8

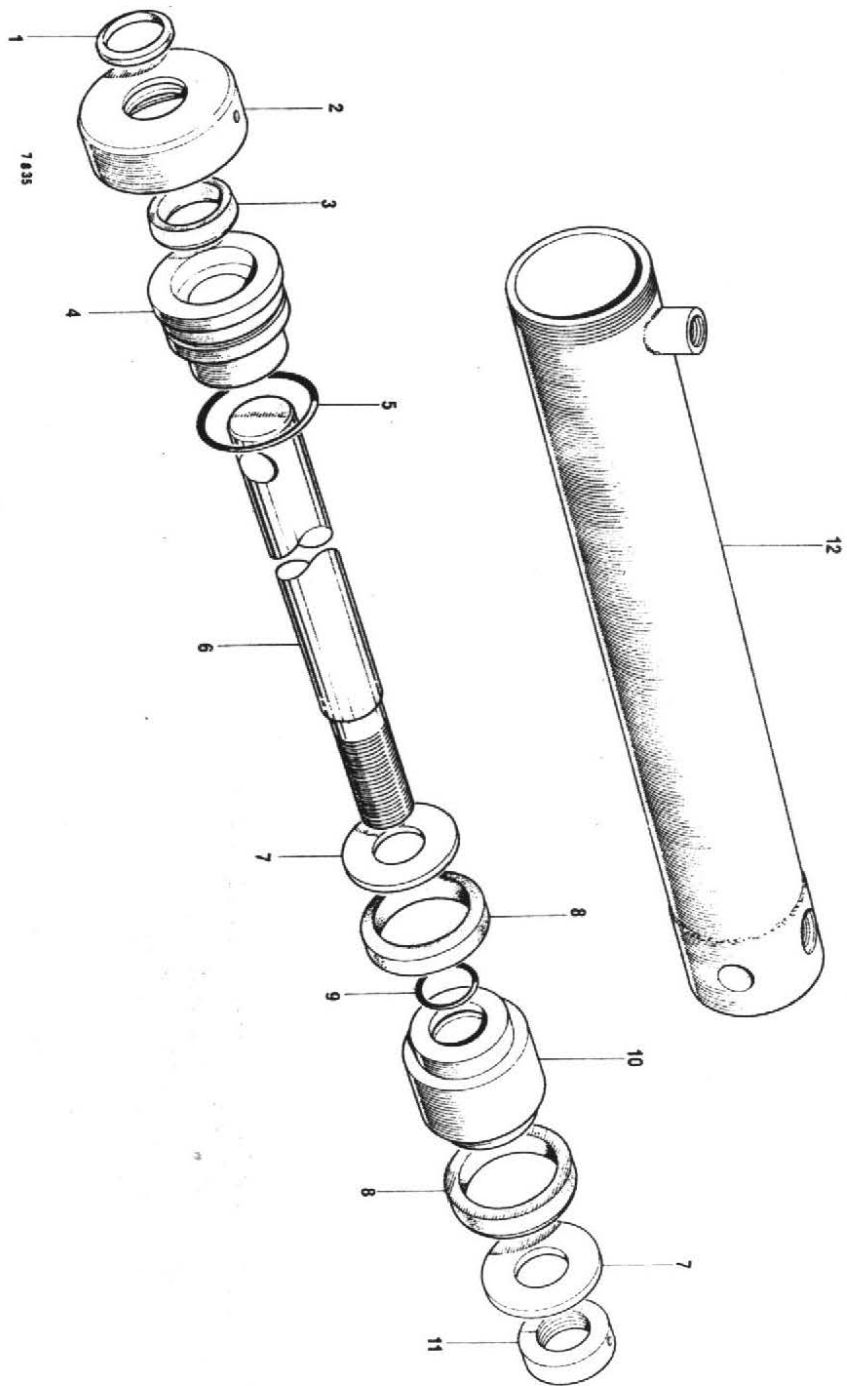

HYDRAULIC CYLINDER – SKIP TIPPING

<i>Item No.</i>	<i>Part No.</i>	<i>Description</i>	<i>No. Off</i>
	3600/75	Hydraulic Cylinder Complete	1
1	3622/75	Wiper	1
2	3603/75	Tube Cap	1
3	3619/75	Sleeve Seal	1
4	3606/75	Tube Sleeve	1
5	3620/75	Sleeve 'O' Ring	1
6	3605/75	Piston Rod	1
7	3618/75	Backing Washer	2
8	3609/75	Piston Seal	2
9	3623/75	Piston Head 'O' Ring	1
10	3604/75	Piston Head	1
11	3621/75	Locknut	1
12	3602A/75	Cylinder	1

5642A

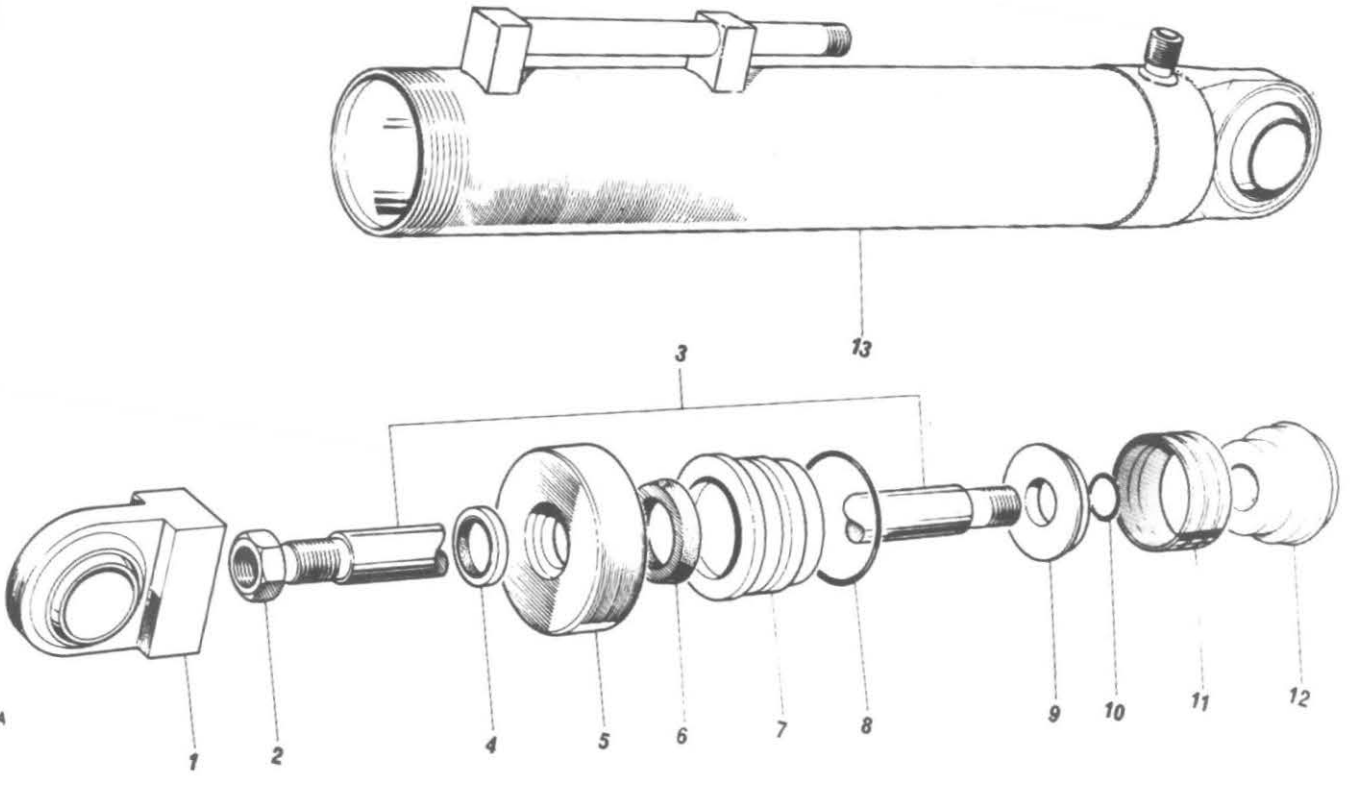

LIFTING CYLINDER

Item No.	Part No.	Description	No. Off
1	TD3894	Cylinder Complete (2 per machine)	1
2	K1/11	Piston Rod Fitting	1
3	K1/19	Locknut	1
4	K1/2	Piston Rod	1
5	K1/18	Wiper	1
6	K1/4	Tube Cap	1
7	K1/17	Sleeve Seal	1
8	K1/5	Sleeve	1
9	K1/16	Sleeve 'O' Ring	1
10	K1/15	Backing Washer	1
11	K1/13	Piston 'O' Ring	1
12	K1/12	Piston Seal	1
13	K1/14	Piston Head	1
	K1/20	Cylinder, Bosses and End Cap	1

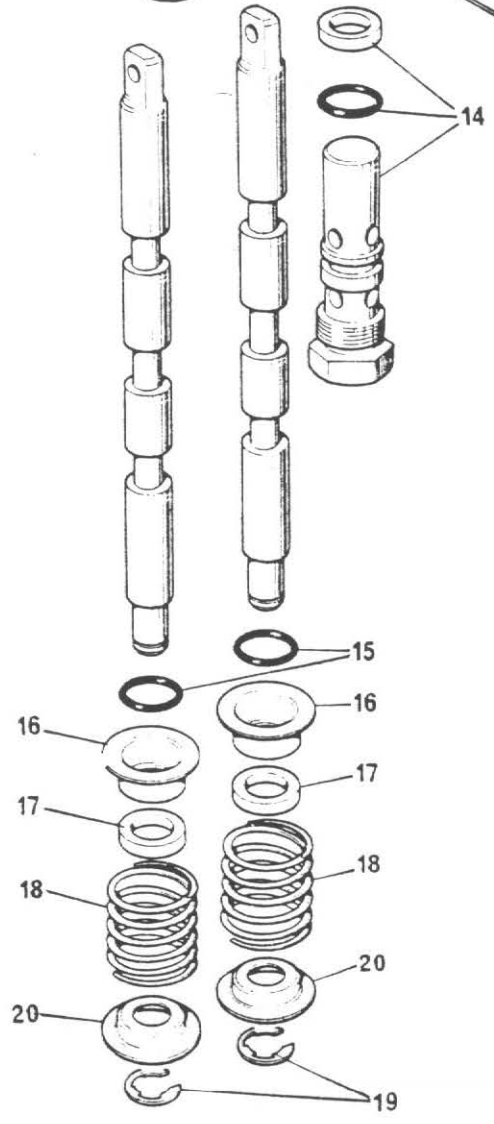
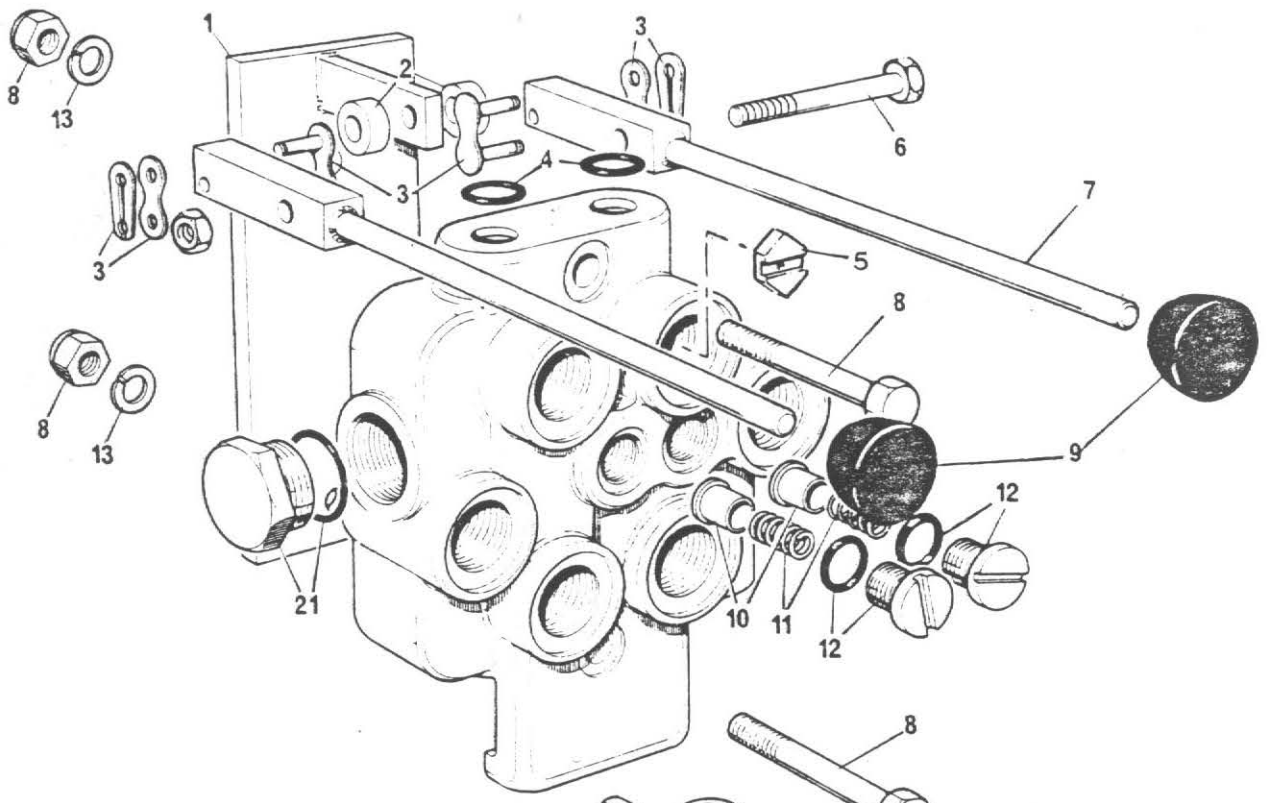

HYDRAULIC VALVE

<i>Item No.</i>	<i>Part No.</i>	<i>Description</i>	<i>No. Off</i>
	300-025-AAU	Hydraulic Control Valve	1
1	4SHL 77	Valve Control Bracket	1
2	2 ST 86	Spacer	2
3	4-60-178	Chain Link	2
4	16004-63	'O' Ring 1/8" x 5/8" I.D.	1
5	16097-451	Orifice Plate	1
6		Bolt 3/8" x 2 3/4" long & Nut	1
7	4SHL 89	Valve Control Lever (Drilled for 3/8" bolt)	2
8		Nut & Bolt 5/16" x 3" Long	2
9	10211 A01	Knob	2
10	30501-12	Plunger, Lift Check	2
11	30501-13	Spring, Lift Check	2
12	30501-17	Plug Assy. Lift Check	2
13		3/8" Spring Washer	2
14	32018-L9	Relief Valve Assy.	1
15	16003-12	'O' Ring 3/32" x 5/8" I.D.	2
16	30501-10	Washer, Deep	2
17	16048-31	Washer 59/64" O.D.	2
18	30501-39	Spring Spool Cr.	2
19	16124-50	Clip Ring 1/2" Shaft	2
20	15546-6	Washer, Shallow	2
21	16069-1140	Plug Assy. 7/8" UNF	1

DECIMAL, FRACTIONAL AND METRIC EQUIVALENTS

Inches		Milli- metres	Inches		Milli- metres
Fractions	Decimals		Fractions	Decimals	
1/64	0.015625	0.397	33/64	0.515625	13.097
1/32	0.03125	0.794	17/32	0.53125	13.494
3/64	0.046875	1.191	35/64	0.546875	13.891
1/16	0.0625	1.588	9/16	0.5625	14.288
5/64	0.078125	1.984	37/64	0.578125	14.684
3/32	0.09375	2.381	19/32	0.59375	15.081
7/64	0.109375	2.778	39/64	0.609375	15.478
1/8	0.125	3.175	5/8	0.625	15.875
9/64	0.140625	3.572	41/64	0.640625	16.272
5/32	0.15625	3.969	21/32	0.65625	16.669
11/64	0.171875	4.366	43/64	0.671875	17.066
3/16	0.1875	4.763	11/16	0.6875	17.463
13/64	0.203125	5.159	45/64	0.703125	17.859
7/32	0.21875	5.556	23/32	0.71875	18.256
15/64	0.234375	5.953	47/64	0.734375	18.653
1/4	0.250	6.350	3/4	0.750	19.050
17/64	0.265625	6.747	49/64	0.765625	19.447
9/32	0.28125	7.144	25/32	0.78125	19.844
19/64	0.296875	7.541	51/64	0.796875	20.241
5/16	0.3125	7.938	13/16	0.8125	20.638
21/64	0.328125	8.334	53/64	0.828125	21.034
11/32	0.34375	8.731	27/32	0.84375	21.431
23/64	0.359375	9.128	55/64	0.859375	21.828
3/8	0.375	9.525	7/8	0.875	22.225
25/64	0.390625	9.922	57/64	0.890625	22.622
13/32	0.40625	10.319	29/32	0.90625	23.019
27/64	0.421875	10.716	59/64	0.921875	23.416
7/16	0.4375	11.113	15/16	0.9375	23.813
29/64	0.453125	11.509	61/64	0.953125	24.209
15/32	0.46875	11.906	31/32	0.96875	24.606
31/64	0.484375	12.303	63/64	0.984375	25.003
1/2	0.500	12.700	1	1.000	25.400

INCHES INTO MILLIMETRES

Inches	0	1	2	3	4	5	6	7	8	9
0	0	25.40	50.80	76.20	101.60	127.00	152.40	177.80	203.20	228.60
10	254.00	279.40	304.80	330.20	355.60	381.00	406.40	431.80	457.20	482.60
20	508.00	533.40	558.80	584.20	609.60	635.00	660.40	685.80	711.20	736.60
30	762.00	787.40	812.80	838.20	863.60	889.00	914.40	939.80	965.20	990.60
40	1016.00	1041.40	1066.80	1092.20	1117.60	1143.00	1168.40	1193.80	1219.20	1244.60
50	1270.00	1295.40	1320.80	1346.20	1371.60	1397.00	1422.40	1447.80	1473.20	1498.60
60	1524.00	1549.40	1574.80	1600.20	1625.60	1651.00	1676.40	1701.80	1727.20	1752.60
70	1778.00	1803.40	1828.80	1854.20	1879.60	1905.00	1930.40	1955.80	1981.20	2006.60
80	2032.00	2057.40	2082.80	2108.20	2133.60	2159.00	2184.40	2209.80	2235.20	2260.60
90	2286.00	2311.40	2336.80	2362.20	2387.60	2413.00	2438.40	2463.80	2489.20	2514.60

Use in conjunction with above table.

Example: Find equivalent mm. for 84 5/8".

$$84'' = 2133.60 \text{ mm.}$$

$$5/8'' = 15.875 \text{ mm.}$$

$$84 \text{ } 5/8'' = 2149.475 \text{ mm.}$$

CALIFORNIA

Proposition 65 Warning

Diesel engine exhaust and some of its constituents are known to the State of California to cause cancer, birth defects, and other reproductive harm