

WINGET

**OPERATING
INSTRUCTIONS
&
SPARE PARTS
LIST
4S VARIABLE
HEIGHT
DISCHARGE
DIESEL
DUMPER**

FIRST ISSUED 1974

REPRINTED JULY 2002

WINGET LIMITED
PO BOX 41
EDGEFOLD INDUSTRIAL ESTATE
PLODDER LANE
BOLTON
LANCS
BL4 OLS
TEL: ++ 44 (0) 1204 854650
FAX: ++ 44 (0) 1204 854663
service@winget.co.uk
parts@winget.co.uk
winget.co.uk

INTRODUCTION

This Parts & Operators Manual is a re-print of the manual last published in 1981 and contains some amended part numbers.

Health & Safety legislation and working practices applicable to Site Dumpers, both 2 and 4 wheel Drive, Rigid Chassis and Articulated Chassis have changed considerably in the years since this manual was last published and immediately following this Introduction are notes on the Safe Use of Site Dumpers. These notes supersede and replace all previous 'Dumper Safety' notes issued with Winget 4S Variable Height Discharge Two Wheel Drive Dumpers

Reference is made on a number of pages to 'bolt c/w nut and washer', this no longer the case, fixings such as nuts, bolts, screws and washers should be ordered as individual items. A number of Whitworth and B.S.F fixings are now no longer available, in these cases the nearest metric equivalent size will be supplied.

The contents of this manual although correct at the time of publication, may be subject to alteration by the manufacturers without notice and Winget Limited can accept no responsibility for any errors or omissions contained within the following pages. Nor can we accept any liability whatsoever arising from the use of this manual howsoever caused.

Winget Limited operate a policy of continuous product development. Therefore, some illustrations or text within this publication may differ from your machine.

WINGET LIMITED
PO BOX 41
EDGEFOLD INDUSTRIAL ESTATE
PLODDER LANE
BOLTON
LANCS
BL4 OLS
TEL ++ 44 (0) 1204 854650
FAX ++ 44 (0) 1204 854663
E mail service@winget.co.uk
parts@winget.co.uk
www.winget.co.uk

Safety is the responsibility of all persons working with this machine. Think "safety" at all times. ***Read and remember the contents of this handbook.***

The safe working recommendations for specific tasks are found with the instructions for the relevant operation in this Handbook.

MACHINE MODIFICATION

WARNING Any modifications to the machine will affect its working parameters and safety factors. Refer to the Manufacturers before fitting any non-standard equipment or parts.



The Manufacturers accept no responsibility for any modifications made after the machine has left the factory, unless previously agreed by the Manufacturers in writing; the Manufacturers will accept no liability for damage to property, personnel or the machine if failure is brought about due to such modifications, or fitment of spurious parts.

TRAINING

WARNING Only trained operators should use this machine.



Operators should hold an appropriate full motor vehicle driving licence and undergo both a safety awareness course and a driver training course for Site dumpers run by the C.ITB or equivalent body leading to the award of a CTA.

It is strongly recommended that operators read the H.S.E. publication "Safe Working with Small Dumpers" which is available from government bookshops (HMSO) or from other bookshops quoting the following number ISBN 011 8836935. Another useful publication is British Standard number BS 6264, "Procedure for Operator Training For Earth Moving Machinery" available from the British Standard Institution.

RUNNING-IN

WARNING While a gradual 'running-in' of a new engine is not necessary, it is extremely important that the instructions given in *Section 2 "Operation"* on "Running-in a new engine" should be followed very closely during the first fifty hours of operation.



DRIVING

WARNING **NEVER** use the machine for purposes other than those for which it was designed. This machine was designed to carry loads such as soil, clay, sand, wet concrete, stone or other similar materials. It was not designed to carry loads which may move around in the skip uncontrollably, nor to carry any loads or materials which overhang the skip in any way. If in any doubt as to the suitability of this machine for a particular task, contact your nearest Distributor or the Manufacturer for advice.



ALWAYS be aware of local and national regulations governing the use of the machine.

NEVER commence work with the machine until the "Daily (or every ten hours)" service checks have been made. (*See Service Section* for details)

ALWAYS check wheel nut tightness daily.

NEVER carry passengers.

Ensure that the seat is securely fixed to the machine. Where seat belt restraints are fitted as part of Rops/Fops protection they must be worn. Check that the seat belt is in good condition, free from cuts and frayed edges.

ALWAYS remain in the driving seat whenever the engine is running. Never attempt to operate any controls unless seated.

ALWAYS apply the parking brake before leaving the driver's seat.

NEVER dismount with the engine running, and never leave the machine unattended with the key in the starter switch.

When Battery Isolators are fitted they must be activated only when the engine is turned off except in cases of emergency.

Activating a Battery Isolator when the engine is running can result in damage to the electrical components and circuits.

NEVER fill the fuel or hydraulic tanks with the engine running.

ALWAYS drive only on surfaces that are known to be stable.

ALWAYS keep the floor plates and walkways clean.

NEVER drive the machine close to the edge of any excavation. Always use effective wheel stops to prevent the machine running close to the edge. Make sure that the stops are in proportion to the size of the wheels and are set sufficiently far enough back from the edge of any excavation to prevent the weight of the load causing a collapse.

NEVER adjust the tyre pressures in an attempt to improve traction on soft ground or obtain a softer ride on hard ground. Incorrectly adjusted tyres can affect the steering and handling characteristics.

NEVER attempt to free a machine which is 'bogged down' by pushing with the bucket of a backhoe loader, tracked excavator or other similar machine.

NEVER make unnecessary "crash stops" when travelling at speed, especially in forward direction.

NEVER work under an unpropped skip. If the dumper was supplied with a special skip support always ensure that it is used.

SKIPS AND LOADING

WARNING NEVER exceed the rated payload. The weights of all loads above skip water level must be checked.



NEVER remain on the machine when loading the skip with excavators or loaders. Stop the engine, apply the parking brake, dismount, and stand well clear.

ALWAYS ensure that the load is evenly distributed in the skip.

NEVER carry loads or heap materials in such a manner as to affect the forward vision.

ALWAYS take extra care when tipping non free running loads.

NEVER use the skip in a tipped position to bulldoze heaped materials level or to backfill material into excavations.

TOWING

WARNING NEVER attempt to start the engine of a dumper by towing or pushing.



Dumpers are not designed as towing vehicles. However, trailers may be towed provided that:

- 1 The combined weight of the trailer and its load does not exceed the dumper "drawbar pull of 250kg (2500N)" and dumper "drawbar load of 50kg (500N)".
- 2 Trailers may be towed in first gear on level dry ground, provided a purpose made towing pin is used.
- 3 The dumper skip must be loaded with half the rated payload to ensure tyre adhesion when braking.

NEVER tow loads up, down or across gradients.

GRADIENTS

WARNING NEVER operate **Two Wheel Drive rigid chassis dumpers** on any gradients which exceed 10% (1 in 10), or across gradients which exceed 10% (1 in 10).



ALWAYS remember that slippery or loose surface conditions can adversely affect safe machine operation, including braking, particularly on gradients.

ALWAYS choose routes that avoid steep, slippery or loose gradients.

NEVER coast down gradients. Always negotiate gradients in first gear.

ALWAYS drive forwards up gradients when loaded.

ALWAYS reverse down gradients when loaded.

ALWAYS keep the load facing uphill.

NEVER park on a gradient. If this is unavoidable, *ALWAYS* chock the wheels.

NEVER attempt to turn on a gradient

NEVER tow up, down or across a gradient.

NEVER operate high discharge or rotating skips on gradients.

HYDRAULICS

WARNING *ALWAYS* "Dump" residual pressure from the system before leaving the machine or before carrying out any maintenance or adjustments.



If maintenance work requires the skip to be in the raised position, then it must be raised and supported before dumping the pressure.

Dump pressure by switching off the engine, then moving the hydraulic control lever several times in each direction.

NEVER leave the machine unattended with pressure in the system.

ALWAYS purge hydraulic rams before commencing work. With the engine running operate the hydraulic control to fully extend and retract the rams.

ALWAYS practise the greatest cleanliness in maintaining hydraulic components.

SERVICING

WARNING *ALWAYS* report any defect at once, before an accident or consequential damage can occur.



ALWAYS conform to service schedules except where:

- 1 Warning lights or warning indicators call for immediate attention.
- 2 Adverse conditions necessitate more frequent servicing.

ALWAYS wear correctly fitting protective clothing. Loose or baggy clothing can be extremely dangerous when working on running engines or machinery.

ALWAYS, where possible, work on or close to engines or machinery only when they are stopped. If this is not practical, remember to keep tools, test equipment and all parts of your body well away from the moving parts.

ALWAYS "Dump" pressure from the hydraulic system before carrying out any kind of maintenance or adjustment. (*see Service - Hydraulic system*).

ALWAYS avoid contact with exhaust pipes, exhaust manifolds and silencers when the engine is running; these can be very hot.

ALWAYS work out of doors, or in a well-ventilated area.

NEVER run an engine in an enclosed space. Exhaust fumes in enclosed areas can kill.

ALWAYS disconnect battery cables and remove battery before using an external charger, carrying out welding repairs or to prevent unauthorised usage when unattended or during a repair.

NEVER allow unqualified personnel to attempt to repair, remove or replace any part of the machine, or anyone to remove large or heavy components without adequate lifting tackle.

NEVER attempt to modify or repair Rops Frames or Fops Canopies by welding, drilling or any other means. Attempts to do so will invalidate Rops/Fops Certification.

ALWAYS obtain advice before mixing oils; some are incompatible. If in doubt drain and refill.

NEVER allow oils and fuels to come into regular contact with skin. This can lead to serious skin diseases including, medical evidence suggests, skin cancer. *ALWAYS* wear protective gloves when handling oils and fuels whether topping up, draining or refilling. *ALWAYS* wash hands if oils or fuels come into contact with the skin.

Many liquids used in this machine are harmful if taken internally or splashed into the eyes. In the event of accidentally swallowing oils, fuels, anti-freeze, battery acid etc, *DO NOT* encourage vomiting, seek qualified medical assistance immediately.

ALWAYS dispose of waste oils and fuels into waste oil storage tanks. If storage tanks are not available consult your distributor or local authority for addresses of local designated disposal points. It is illegal to dispose of waste oil into drains or water courses or to bury it.

Equipment which includes friction materials will sometimes contain asbestos. When removing friction material dust from components, such as when servicing brakes or clutches, do not blow out with an airline; it could be harmful to inhale the dust. Remove the dust with a vacuum cleaner or wipe clean with a damp rag. Waste should be placed in a sealed container, marked, and disposed of in accordance with local or national regulations.

The accumulated dust found in clutch housings may contain lead/antimony. No food should be eaten at a work place contaminated by this dust. Hands must be washed before eating. Do not blow out dust with an airline.

NEVER work under an unpropped skip. ***If the dumper was supplied with a special Skip Support always ensure that it is used.***

ALWAYS ensure that when using a starting handle that it is clean and in good condition. Keep the engine starting dog and the part of the starting handle that mates with it lightly lubricated (*Refer to the Engine Handbook*).

PREPARATION FOR USE

BEFORE THE DUMPER IS PUT INTO SERVICE, ALWAYS CHECK THE FOLLOWING POINTS –

1. **Engine**
Check the oil level on the dipstick (A), topping up if necessary to the full mark. See also 'Recommended Lubricating Oils', page 14.
2. **Gearbox**
Check the oil level on the dipstick (B), topping up if necessary to the full mark. See also 'Recommended Lubricating Oils' page 14.
3. **Drive Axle**
Remove level/filler plug (C) and check that oil is up to bottom of hole. Top up if necessary. See also 'Recommended Lubricating Oils', page 14.
4. **Fuel Tank**
Fill tank (D) with diesel oil until approximately 1" from the top.

NOTE: See Periodic Maintenance (2).

5. **Hydraulic Tank**
Fill the hydraulic tank (E). Before removing the cap, clean the surrounding area, to prevent the possible entry of foreign matter. DO NOT MIX OILS. See also 'Recommended Lubricating Oils', page 14.
6. **Brake System**
Ensure that the brake master cylinder reservoir (F) is full of brake fluid. Top up if necessary, to within 1/4" of the top of the reservoir. Use only Girling Crimson Brake Fluid.
7. **Miscellaneous**
Check all wheel nuts for tightness.
Check all nuts and bolts for tightness. Loose nuts and bolts may lead to damage not covered by the Dumper Warranty.

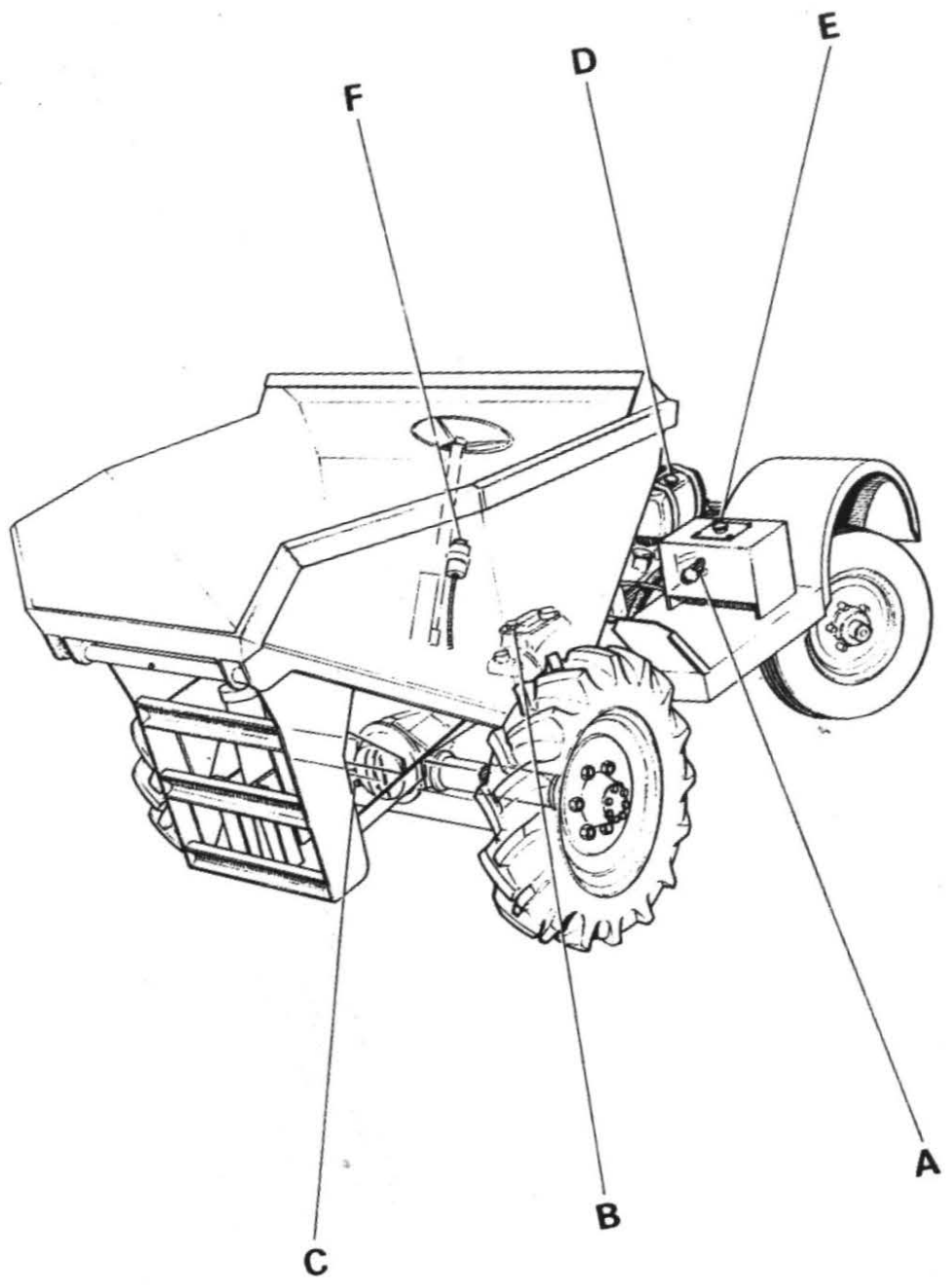

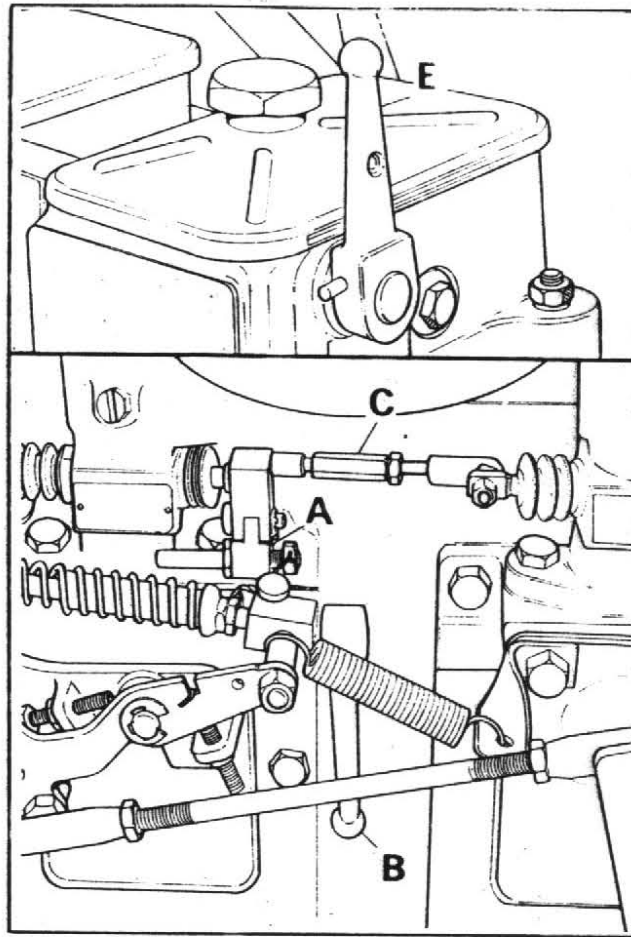

FIG 4

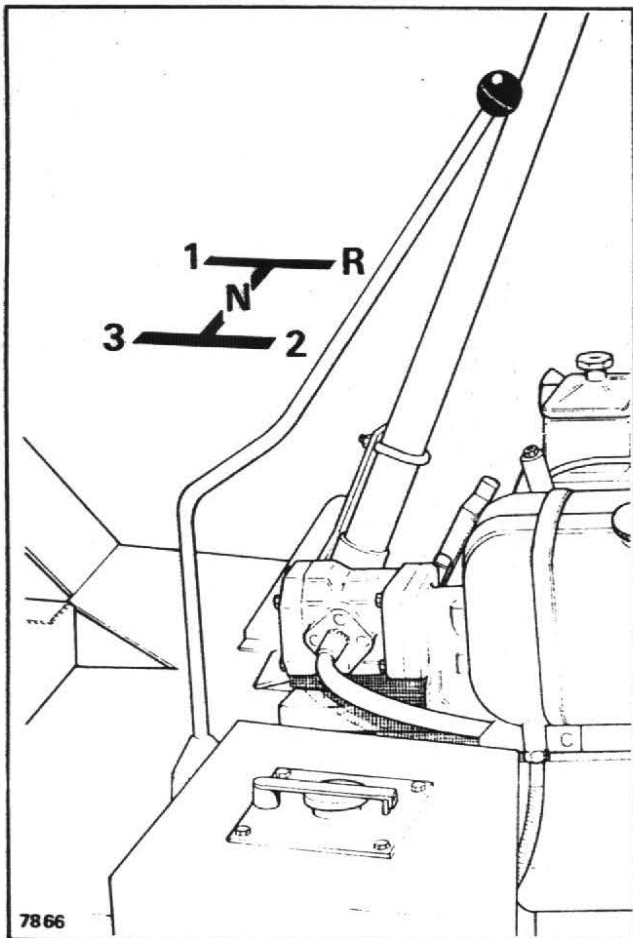

FIG 5

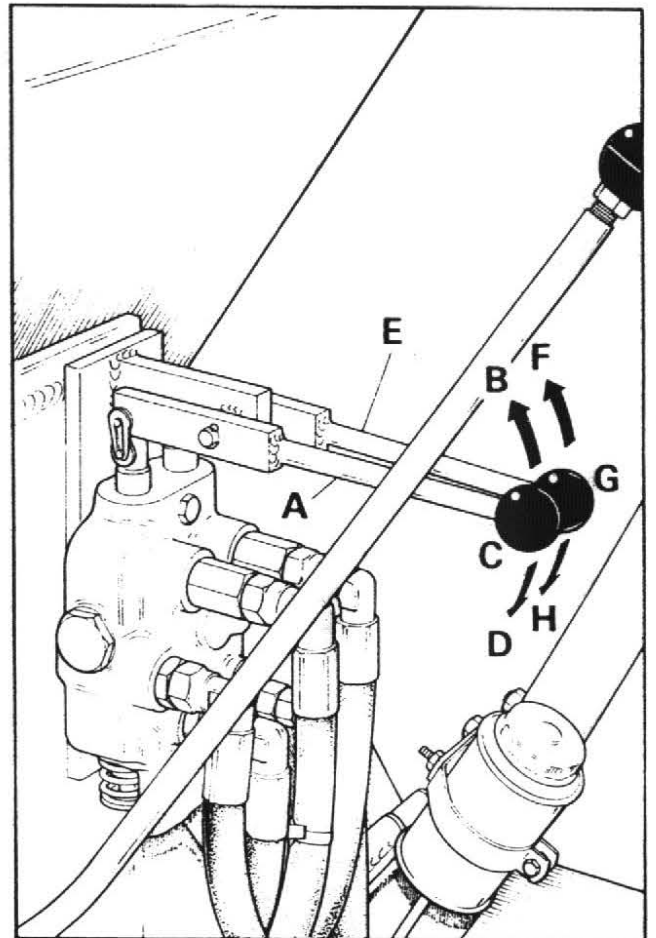

FIG 6

OPERATION

Starting

Fig. 4 (Petter)

1. Lift red-painted overload stop (A) situated on fuel pump immediately above priming lever (B), and move fuel pump racks (C) into fully-open position (PETTER ENGINE).
2. Operate priming lever (B) six times.

NOTE: This is unnecessary if engine is already warm.

3. Lift decompression levers (E), positioned on top of engine and turn engine as fast as possible using starting handle. When engine is turning at a good speed, knock down decompression levers and engine should fire.
4. If engine does not fire, lift decompression lever and slowly crank engine a few times before attempting to start again. Where ambient temperature is 5^oF (-15^oC) or below, a cold starting aid should be fitted.

Stopping

Fig. 4 (Petter)

Hold the fuel pump rack (C) in the fully forward position, or lift the priming lever to the horizontal, until engine stops and then release (PETTER ENGINE).

IMPORTANT

1. DO NOT stop engine by means of decompression levers, this will lead to damaged valve seats and cylinder head joints.
2. DO NOT stop engine by closing fuel tap or by allowing fuel tank to run dry. This will allow air into fuel lines and necessitate bleeding and priming system.

Gear Shift Lever

Fig. 5

The dumper is fitted with three forward gears and one reverse gear. When changing gear, the clutch pedal is used in the normal manner.

Skip Control Lever

Fig. 6

1. Control lever (A) has three positions, DUMP (B), HOLD (C) and RETURN (D).
2. Pull lever up to DUMP (B) to deposit load.
3. Push lever down to RETURN (D) to return the skip to the carrying position.

NOTE: If lever is released when in DUMP or RETURN positions, it will automatically return to HOLD (C) position and motion of skip will cease. In this way, speed at which load is deposited can be finely controlled.

Variable High Discharge Control Lever

Fig. 6

1. Control lever (E) has three positions, UP (F), HOLD (G) and DOWN (H).
2. Pull lever up to UP (F) to raise discharge height.
3. Push lever down to DOWN (H) to lower discharge height.

NOTE: If lever is released when in UP or DOWN positions, it will automatically return to HOLD (G) position and motion of skip will cease. In this way, height at which skip discharges can be finely controlled.

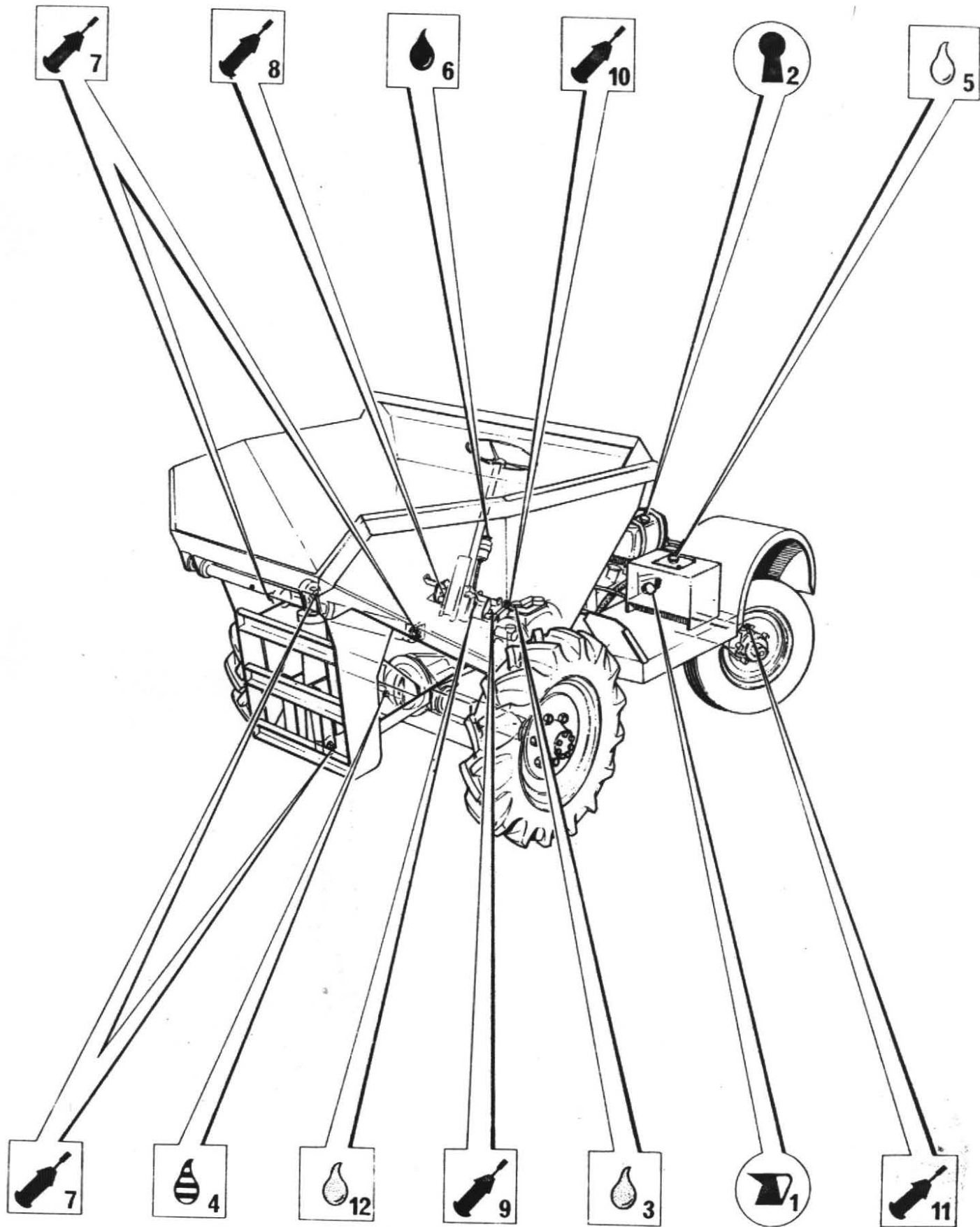

GENERAL MAINTENANCE

Lubrication

Daily

		No. of points
○ 1	Engine oil	1
○ 2	Fuel Tank	1

Weekly

3	Gearbox - oil	1
4	Drive Axle - oil	1
5	Hydraulic Tank - oil	1
6	Brake Master Cylinder Reservoir - brake fluid	1
□ 7	Ram Bearings - grease (variable height ram)	2
□ 8	Footbrake Pedal - grease	1
9	Clutch Pedal - grease	1
10	Clutch Cross Shaft - grease	2
11	Steering Hub and Ball Ends – grease	10
12	Steering Box - oil	1

Key

	Engine oil
	Gearbox oil
	Axle oil
	Hydraulic fluid
	Brake fluid
	Grease gun
	Diesel fuel

- NOTES:**
1. Rear Axle Articulation Points consist of silentbloc bushes and do not require lubrication.
 2. For full details on the lubrication and maintenance of the engine, refer to the appropriate manufacturer's manual.

Recommended Lubricating Oils

See page 14

Periodic Maintenance

1. DAILY check engine oil level and fill to full mark on dipstick, if necessary.
2. DAILY fill fuel tank, or as often as proves necessary, to within approximately 1" of top of tank. Maintain a minimum of 2" of fuel in tank.
3. WEEKLY check oil level in gearbox and fill to full mark on dipstick, if necessary.
4. WEEKLY remove level/filler plug from drive axle. Oil level should be to bottom of hole. Top up, if necessary.
5. WEEKLY check oil level in hydraulic tank. Always clean surrounding area before removing cap, to prevent possible entry of foreign matter. Fill tank, if necessary, to within 1" of top.
6. WEEKLY check brake fluid in master cylinder reservoir and top up if necessary, to within 1/4" of top.
7. WEEKLY apply grease to all grease nipples.
8. WEEKLY check all wheel nuts and tighten, if necessary.
9. OCCASIONALLY check all nuts and bolts and tighten if necessary.

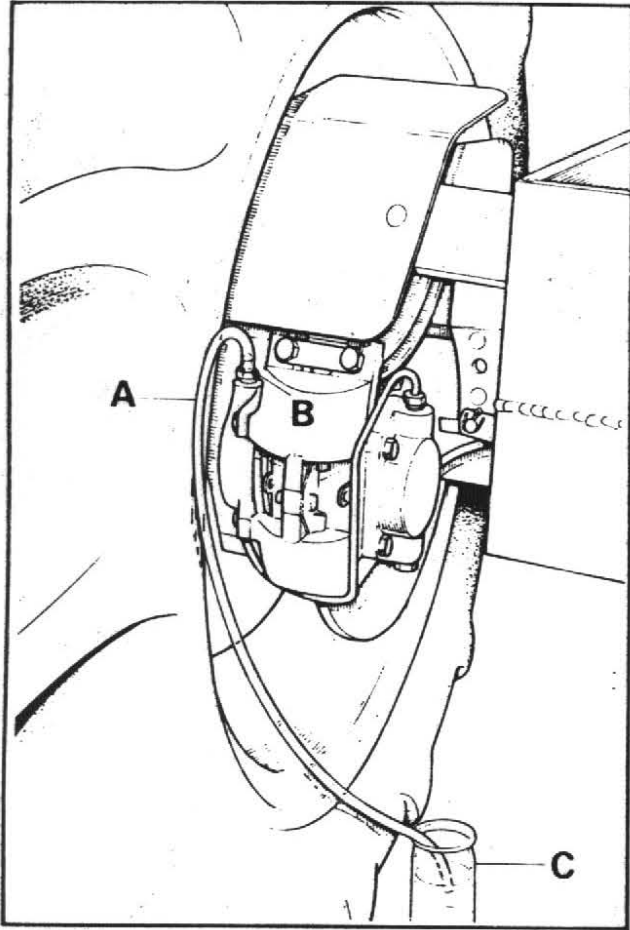

FIG 1

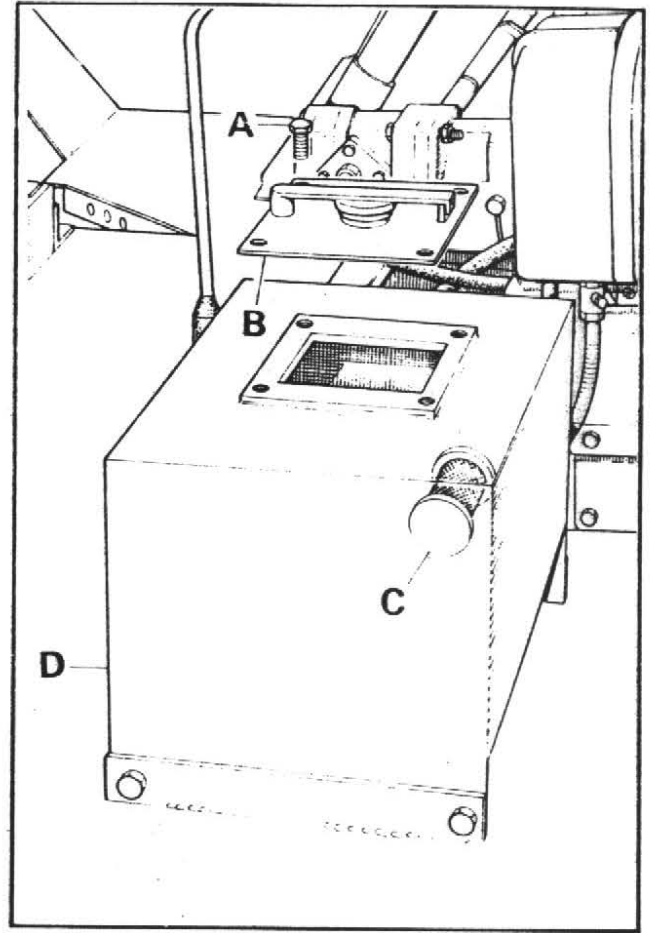

FIG 2

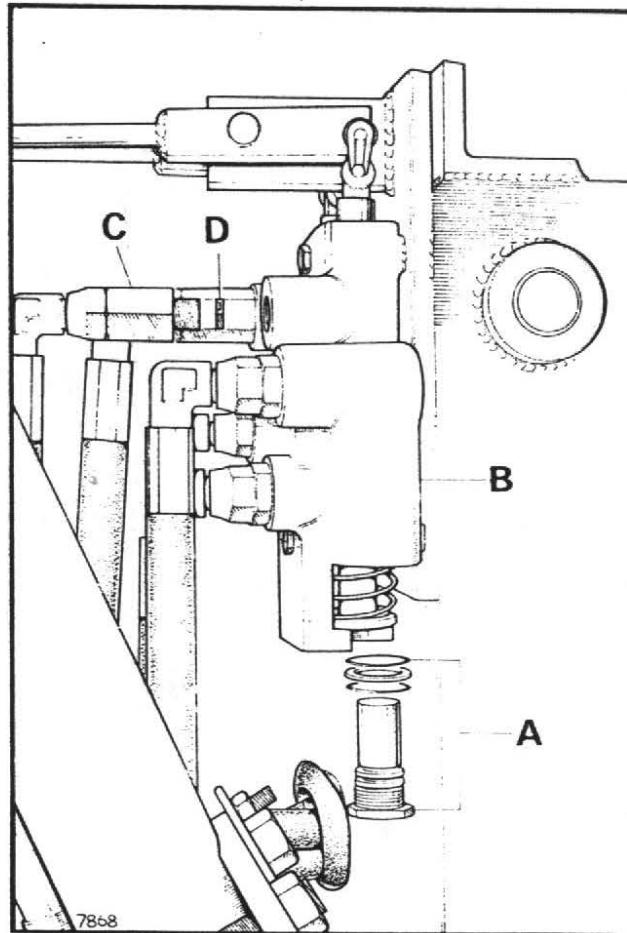

FIG 3

Brake System

The brake system is designed to require the minimum of maintenance, and, providing that the hydraulic fluid in the reservoirs is not allowed to fall below the recommended level, no defects should normally occur. Fluid loss must be supplemented by topping up the reservoir with Girling Crimson Brake Fluid. No other fluid may be used. If air is present in the system, it will be indicated by sluggish response of the brake or by spongy action of the brake pedal. This may be due to air being introduced at a loose joint or by the reservoir fluid level being allowed to fall to a very low level. These defects must be remedied immediately and the complete system bled.

To bleed the system, proceed as follows. During the operation it is essential that the reservoir level is kept topped up to prevent further air from being drawn into the system. Only use new fluid for topping-up.

Fig. 1

1. Check that all connections are tight and all bleed screws are closed.
2. Fill reservoir with Girling Crimson Brake Fluid.
3. Attach bleeder tube (A) to bleed screw (B) of one wheel and immerse other end in a small quantity of brake fluid contained in a glass jar (C). Slacken bleed screw and operate brake pedal up and down through its full stroke until fluid pumped into jar contains no air bubbles. Hold down pedal and close bleed screw. Remove bleeder tube and release pedal.
4. Repeat on other wheel.
5. Lock both bleed screws and top up reservoir to correct level.
6. Apply normal working load on brake pedal for two or three minutes and examine entire system for leaks.

Main Hydraulic System

The main hydraulic system controls the dumping and return of the skip. If the skip fails to operate or does so extremely slowly, carry out the following procedures until the fault is rectified.

1. Check that hydraulic tank is full of oil.

Fig. 2

2. a) Remove four setscrews (A) securing filler cap assembly (B) and remove assembly.
b) Unscrew suction filter (C) from inside of tank (D) and wash in white spirits. Dry with moisture-free compressed air.
c) Replace suction filter and filler cap assembly.

NOTE: If suction filter cannot be thoroughly cleaned, fit a new one.

3. Check that hydraulic pressure is correct.
a) Fit a 2500 p.s.i. gauge into hydraulic line to base of rams.
b) Operate control lever(s) to dump skip (raise skip frame) and check that pressure reading on gauge is 2000 p.s.i. when ram is fully-extended and relief valve is 'blowing'.

Fig. 3

4. Remove relief valve cartridge (A) (hexagon head) from end of control valve (B) opposite to control lever(s) and replace with a new one.
5. Remove hose adaptor (C) from control valve, remove hexagonal orifice plate (D) and wash in white spirit. Dry using moisture-free compressed air. DO NOT poke wire, etc. into orifice. Re-fit plate and hose adaptor, with slot of orifice plate facing outwards.

If none of these procedures correct the fault, contact your local Winget agent.

Periodically check the hose between the pump and the hydraulic tank to ensure that it is not deformed. Any deformation in the hose may result in a vertical flow and damage to the pump.

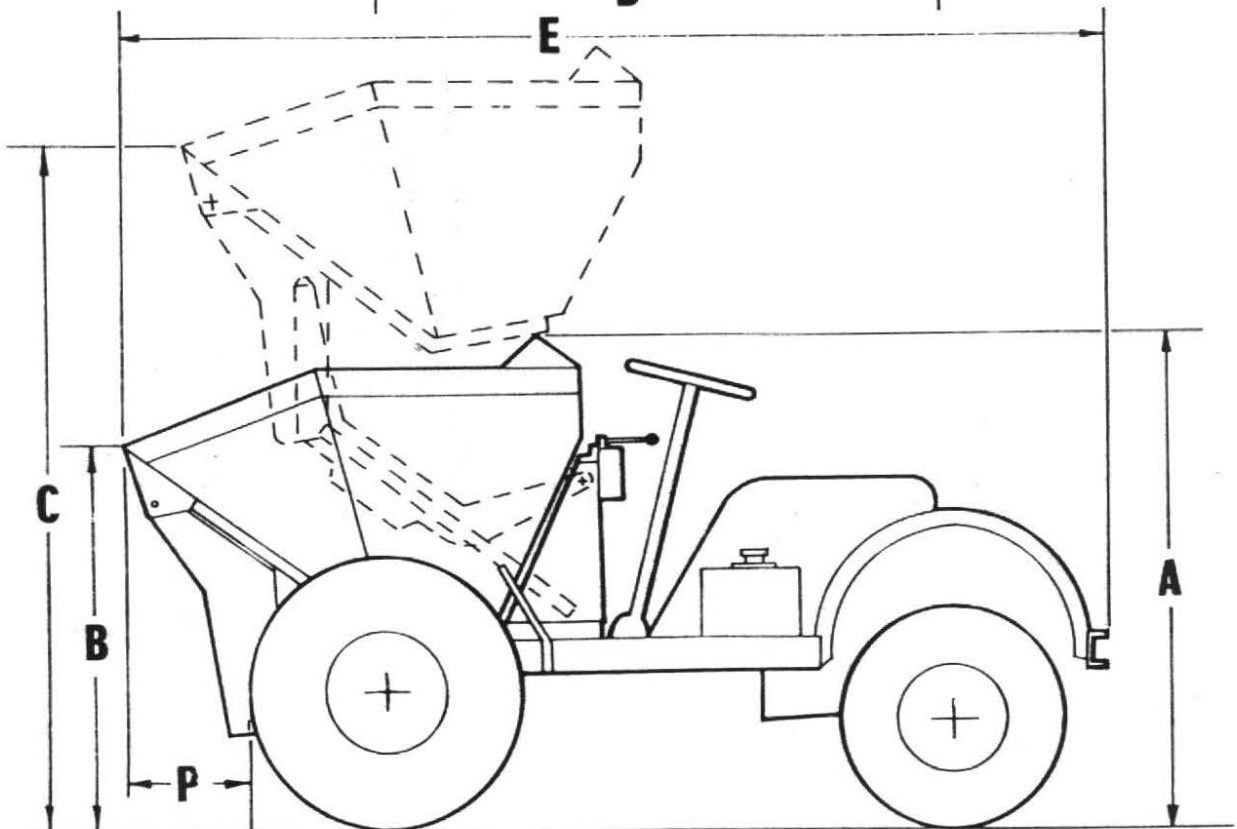
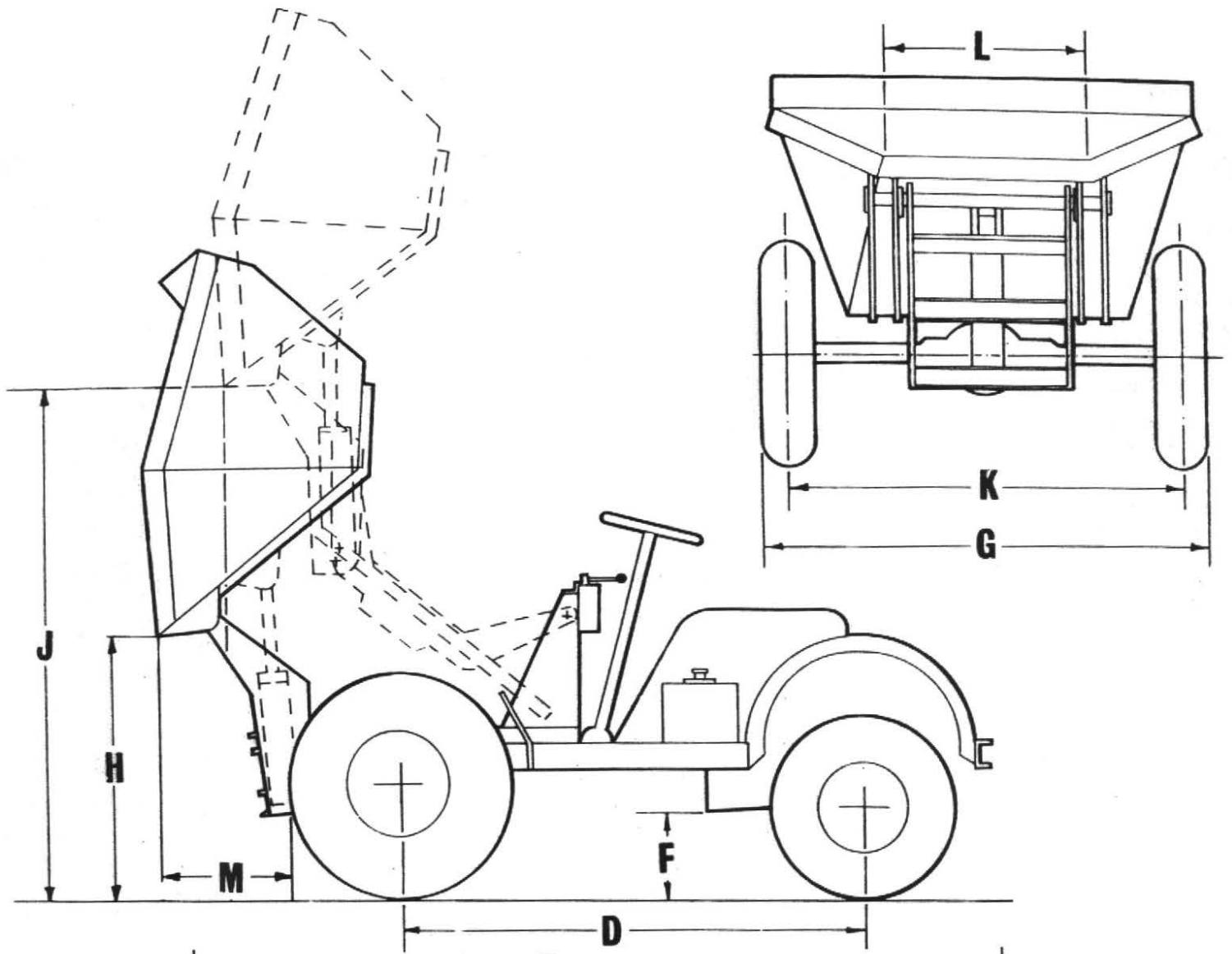

SPECIFICATION
4S VARIABLE HIGH DISCHARGE DUMPER

Dimensions

A	Overall height	5' 3"	(1.60 m)
B	Skip loading height low	4' 3"	(1.30 m)
C	Skip loading height high	7' 2"	(2.18 m)
D	Wheelbase	5' 9"	(1.75 m)
E	Overall length	10' 6"	(3.20 m)
F	Ground clearance	10"	(0.25 m)
G	Overall width	5' 6"	(1.68 m)
H	Skip ground clearance when tipped low	3' 7"	(1.09 m)
J	Skip ground clearance when tipped high	6' 6"	(1.98 m)
K	Wheel track	4' 10"	(1.47 m)
L	Skip discharge width	2' 9"	(0.84 m)
M	Skip discharge distance low	1' 10"	(0.56 m)
N	Skip discharge distance high	12"	(0.30 m)

Skip Capacities

Water Level	24 ft ³	(0.68 m ³)
Struck Level	30 ft ³	(0.85 m ³)
Heaped	37 ft ³	(1.05 m ³)

Road Speeds

	M.P.H.	Km/H
1st forward	3.00	4.8
2nd forward	6.75	10.8
3rd forward	12.5	20.1
Reverse	3.25	5.2

Tank Capacities

Diesel fuel tank		
Hydraulic oil tank	4 imp. galls	(18 litres)
Turning circle	27' 0"	(8.25 m)
Vehicle weight	1 ton 11 cwt. 3qrs.	(1613 kg.)
Hydraulic relief valve	2000 lb/in ²	(140 kg/cm ²)
Working pressure	1500 lb/in ²	(105 kg/cm ²)
Rear axle articulation	1' 2"	(0.35 m)

RECOMMENDED LUBRICATING OILS

Company		Engine		Drive Axle	Gearbox	Wheel Bearings & Other Grease Points	Hydraulic System
		Petter PH	Lister SR				
ESSO	(U.K.) Summer Winter	Estor HD 20		Esso Gear Oil GP 90/140	Estor HD 30	Beacon 2	Nuto H 44
	(Overseas) Above 90°F 32-90°F Below 32°F	Essolube HD 30 Essolube HD 20 Essolube HD 10W		Esso Gear Oil GP 90/140 Esso Gear Oil GP 90/140 Esso Gear Oil GP 80	Essolube HD 30	Beacon 2	
CASTROL	(U.K.) Summer Winter	Deusol CRI 20		Deusol Gear EP 90	Deusol CRI 30	Castrol Spheerol APT 2	Castrol Hyspin AWS 32
	(Overseas) Above 90°F 32-90°F Below 32°F	Deusol CRI 30 Deusol CRI 20 Deusol CRI 10		Deusol Gear EP 140 Deusol Gear EP 90 Deusol Gear EP 80	Deusol CRI 30	Castrol Spheerol APT 2	
SHELL	(U.K.) Summer Winter	Rotella S Oil 20/20W		Spirax 90EP	Rotella S Oil 30	Retinax A	Tellus Oil 27
	(Overseas) Above 90°F 32-90°F Below 32°F	Rotella S Oil 30 Rotella S Oil 20/20W Rotella S Oil 10W		Spirax 140 EP Spirax 90 EP Spirax 80 EP	Rotella S Oil 30	Retinax A	
BP	(U.K.) Summer Winter	Energol DD 20W		BP Gear Oil SAE 90 EP	Energol DD 30	Energrease L2	Energol HL 65
	(Overseas) Above 90°F 32-90°F Below 32°F	Energol DD 30 Energol DD 20W Energol DD 10W		BP Gear Oil SAE 140 EP BP Gear Oil SAE 90 EP BP Gear Oil SAE 80 EP	Energol DD 30	Energrease L2	
MOBIL	(U.K.) Summer Winter	Mobil Delvac Special or Mobil Delvac 1120		Mobilube GX 90	Mobil Delvac 1130	Mobilgrease MP	Mobil DTE Oil Light
	(Overseas) Above 90°F 32-90°F Below 32°F All Temperatures	Mobil Delvac 1130 Mobil Delvac 1120 Mobil Delvac 1110 Mobil Delvac Special		Mobilube GX 140 Mobilube GX 90 Mobilube GX 80	Mobil Delvac 1130	Mobilgrease MP	

IN THE UNLIKELY EVENT OF THE ABOVE OILS NOT BEING AVAILABLE
EQUIVALENT OILS SUPPLIED BY A REPUTABLE MANUFACTURER MAY BE USED

SPARE PARTS SECTION

LIST OF CONTENTS

TITLE	PAGE NO.
CHASSIS	20-21
SKIP & FRAME	22-23
CLUTCH ASSEMBLY	24
GEARBOX	25-28
DRIVE AXLE	29-32
PROPSHAFT & COUPLING	33
DRIVE WHEELS/FRONT	34
STEERING WHEELS/REAR	35
STEERING AXLE	36-37
STEERING GEAR (CAM & ROLLER) LATE	38-39
STEERING GEAR (CAM & ROLLER) EARLY	40-41
STEERING GEAR (RECIRCULATING BALL)	42-43
PEDALS & CONTROLS	44-45
HANDBRAKE ASSEMBLY	46
BRAKE CALIPER	47
BRAKE PIPES & FITTINGS	48
MASTER CYLINDER	49
HYDRAULICS	50-51
HYDRAULIC PUMP	52
TIPPING CYLINDER	53-54
LIFTING CYLINDER	55
CONTROL VALVE	56-57

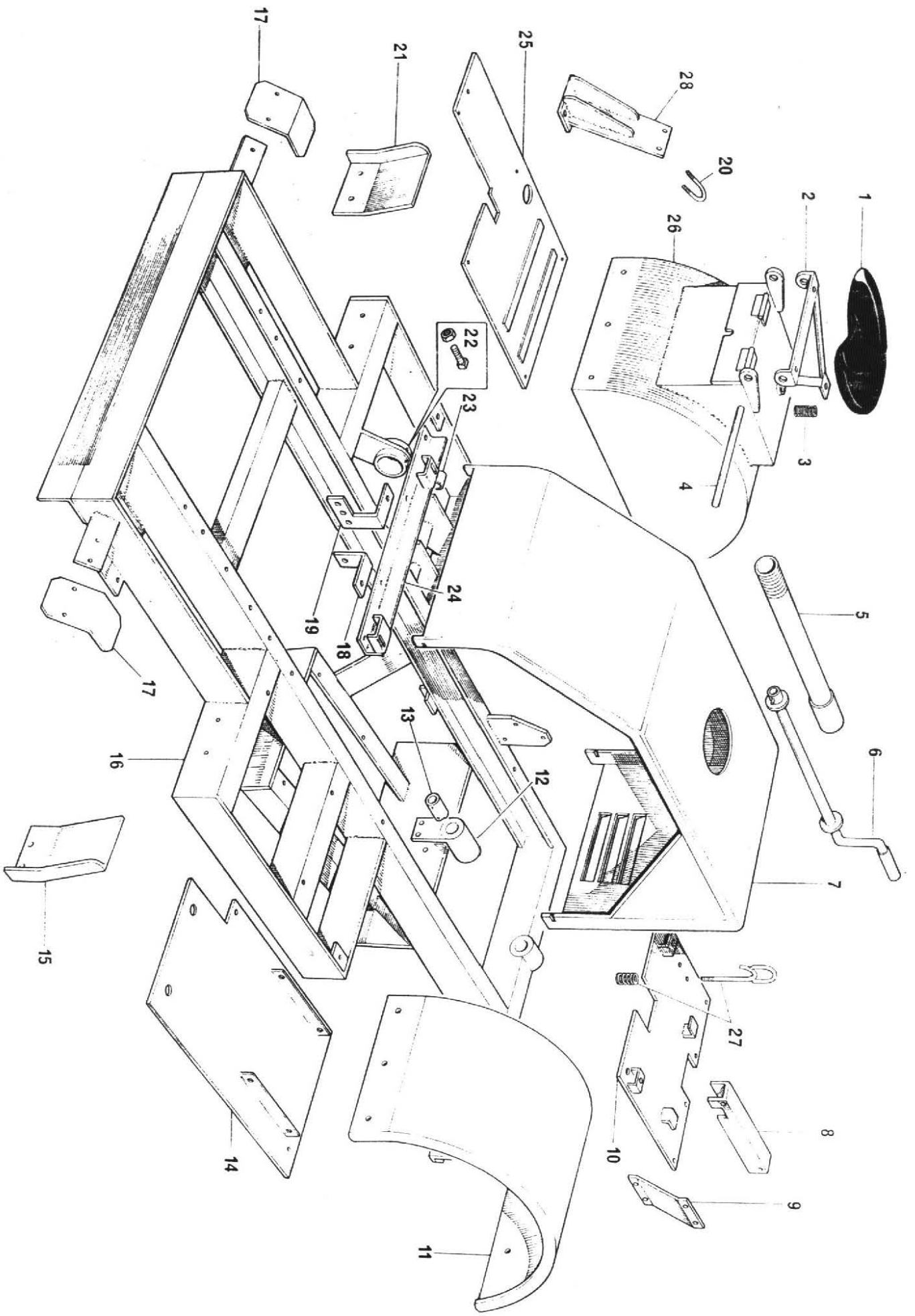

CHASSIS, WINGS ETC.

<i>Item No.</i>	<i>Part No.</i>	<i>Description</i>	<i>No. Off</i>
1	C.182	Pan Seat	1
2	5ST.80	Seat Frame	1
3	5ST.99	Seat Spring	1
4	4-35-79	Seat Rod	1
5	5S.111	Exhaust Pipe	1
6	F.534	Starting Handle	1
7	5ST.3	Cover	1
8	F.539	Upper Fuel Tank Support	1
	4S.148	Upper Fuel Tank Support from m/c. No. 141	1
9	F.540	Lower Fuel Tank Support	1
	4S.147	Lower Fuel Tank Support from m/c. No. 141	1
10	4S.109	Rear Cover	1
11	L.252B	Rear Mudwing L.H.	1
12	4S.100B/21A	Starter Dog Shroud	1
13	L.259P	Starter Dog	1
14	4SH.58	Cover, L.H.	1
15	L.283	Mudflap L.H.	1
16	4SHL.67	Chassis	1
17	5S.109	Disc Brake Cowling	2
18	4S.104	Gearbox Support L.H.	1
19	4S.104A	Gearbox Support	1
20	C.125	'U' Bolt & Nuts	1
21	L.283	Mudflap R.H.	1
22	C.212	Locking Nuts & Bolts	2
23	WB.0808	Accelerator Tube Bush	2
24	5ST.90	Engine Cover Support	1
25	4S.105	Cover R.H.	1
26	L.252A	Rear Mudwing R.H.	1
27	L.287B	Starting Handle Clip & Spring	1
28	C.117	Steering Column Support	1

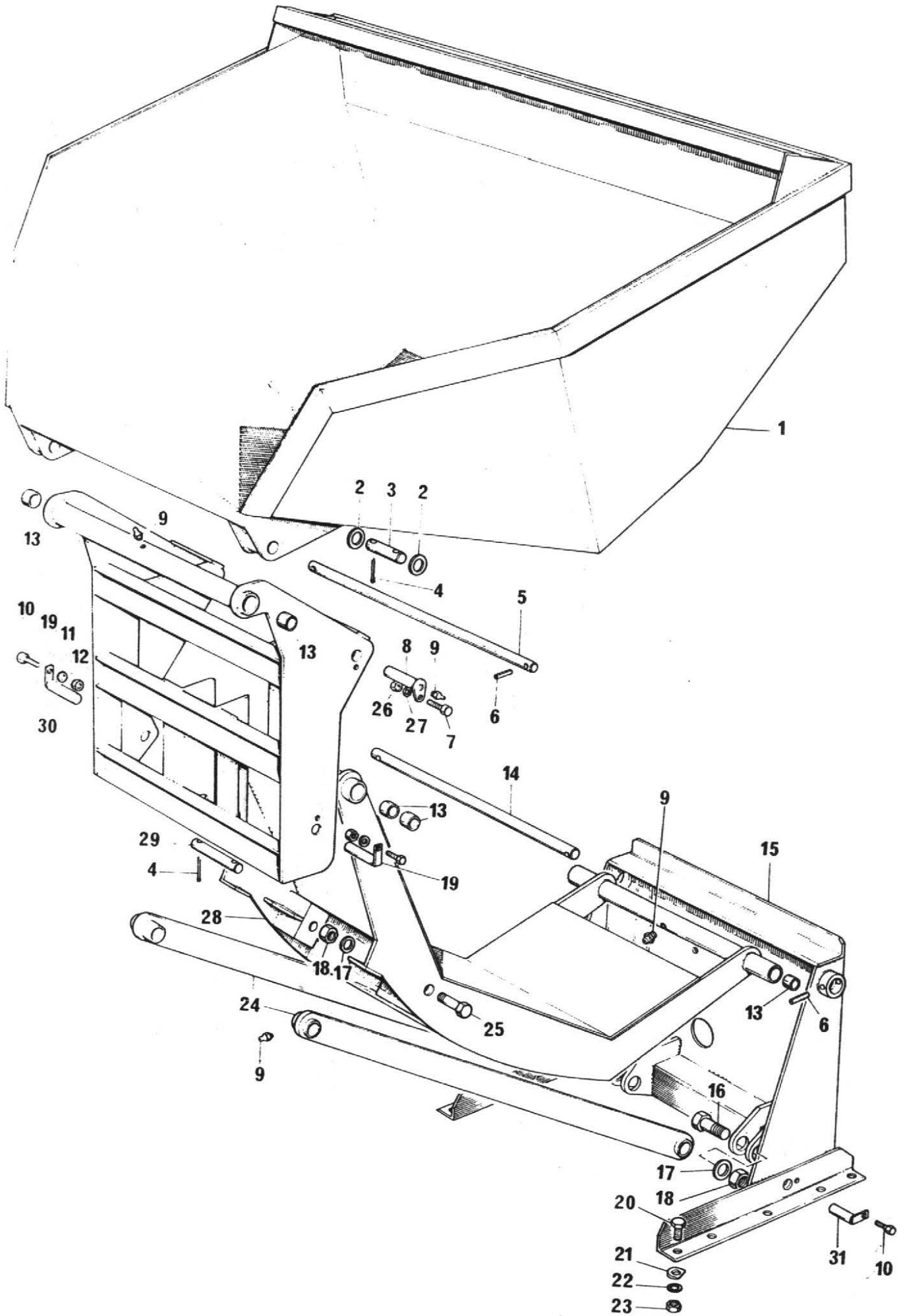

SKIP AND FRAME ASSEMBLY

<i>Item No.</i>	<i>Part No.</i>	<i>Description</i>	<i>No. Off</i>
1	4SHL.75	Skip	1
2		Flat Washer 1" Dia.	2
3	4SHL.65	Ram Pin	1
4		Split Pin 3/16" Dia. x 1.1/2"	2
5	4SHL.62	Skip Pivot Pin	1
6	4-35-29A	Tension Pin 5/16" Dia. x 2.1/4"	4
7		5/16" UNF Bolt x 1" Long	2
8	4SHL.61	Pin Lift Arm	2
9	5ST.100	Grease Nipple	8
10		Hex. Bolt 1/4" UNF x 1" Long	4
11		Spring Washer 1/4" Dia.	4
12		Hex. Nut 1/4" UNF	2
13	4SHL.91	Bush	8
14	4SHL.63	Pin - Lift Arm	1
15	4SHL.69	Rear Frame	1
16	4-35-110A	Ram Bolt	2
17		Spring Washer 1.1/4" Dia.	4
18	4-35-110B	Hex. Nut	4
19	4SHL.60	Link Pin - Front Frame	2
20		Hex. Bolt 1/2" UNF x 1.1/4" Long	10
21		Tapered Washer 1/2" Dia.	10
22		Spring Washer 1/2" Dia.	10
23		Hex. Nut 1/2" UNF	10
24	4SHL.56	Link	2
25	4SHL.64	Bolt	2
26		Hex. Nut 5/16" UNF	2
27		Spring Washer 5/16" Dia.	2
28	4SHL.72	Skip Lifting Frame	1
29	4SHL.66	Ram Pin	1
30	4SHL.68	Front Frame	1
31	4SHL.79	Link Pin - Fixed Frame	2

FLYWHEEL AND CLUTCH ASSEMBLY

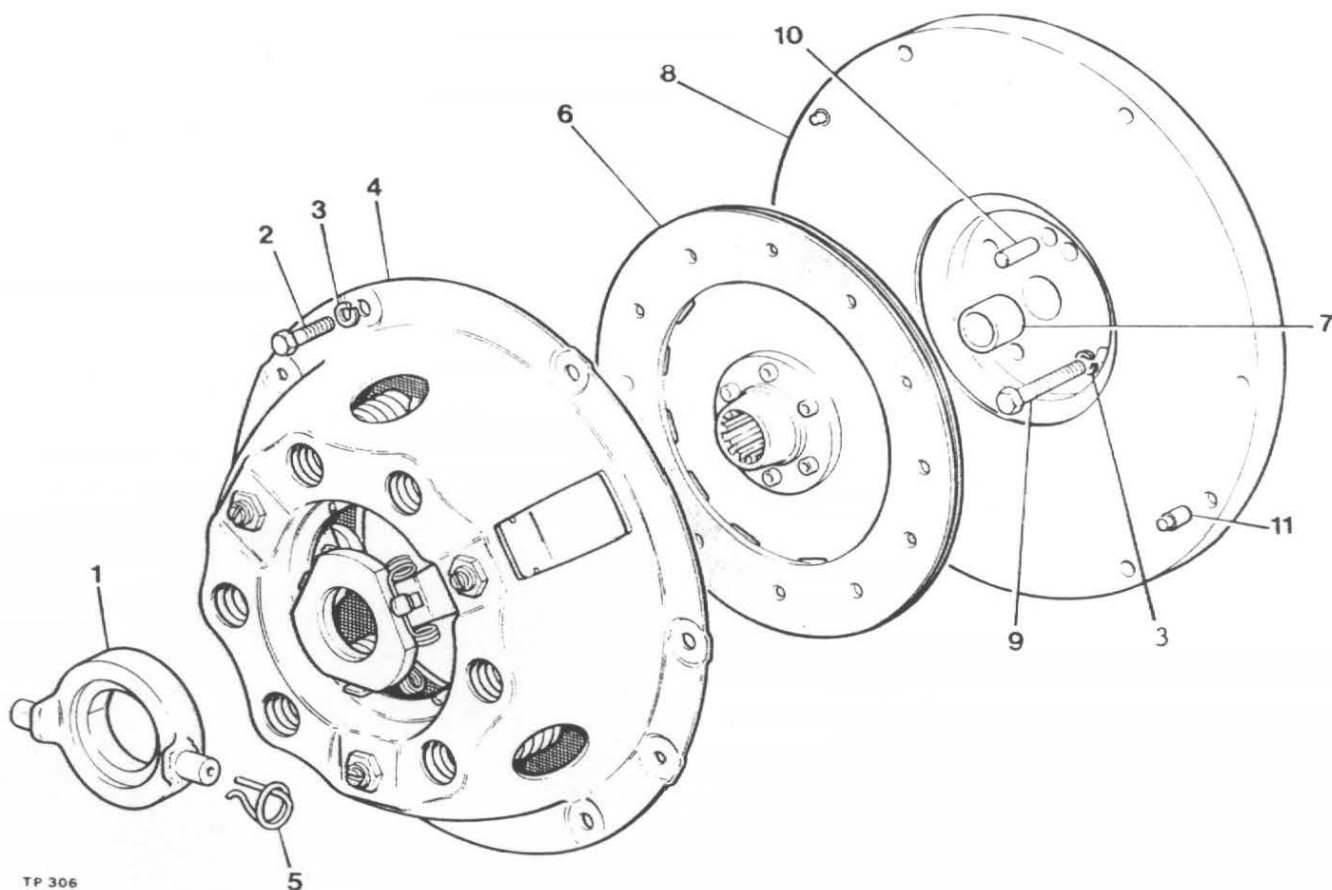

TP 306

Item No.	Part No.	Description	Qty.
1	10579A01	Clutch Release Bearing	1
2	28S02D	Screw Set	6
3	41S04	Washer Spring	10
4	10597A01	Cover Assembly	1
5	10579A101	Retainer Spring	2
6	10598A02	Drive Plate	1
7	10580A0101	Bush	1
8	10580A02	Flywheel Assembly (comprises of items 7, 8, & 11)	1
9	1S02C	Bolt, Petter PH Engine (drill for locking wire)	4
9A	6S02B	Bolt, Lister Engine (drill for locking wire)	4
10	C321	Dowel	1
11	10580A0102	Dowel	2
	10948A02	Clutch Kit (comprises of items 1, 4, 5 & 6)	1

It is recommended that instead of drilling the head of the bolts (item 9) for locking wire that one of each of tabwashers part no's 10531A02 and 10531A03 are used to prevent the bolts working loose.

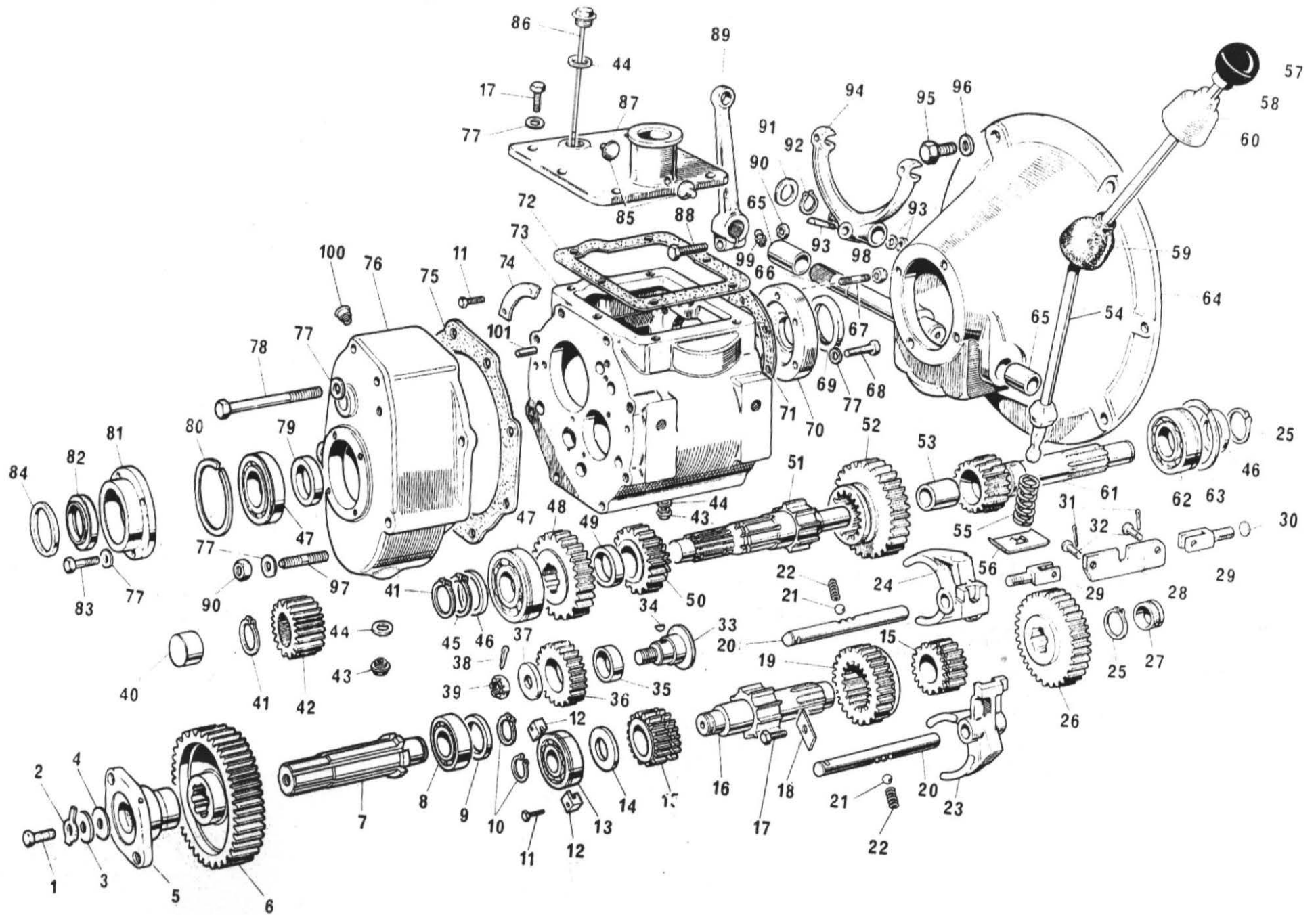

GEARBOX 40M/824 WITH 40M/372 GEAR LEVER

<i>Item No.</i>	<i>Part No.</i>	<i>Description</i>	<i>No. Of</i>
1	USF55	Screw, Coupling	1
2	CM2050	Lockwasher	1
3	CM2123	Washer, Coupling	1
4	40M/340	Washer, Fibre	1
5	40M/383	Flange, Drive (Type 70) 9/16" Bolts	1
6	40M/314	Gear, Driven	1
7	40M/313	Shaft, Output	1
8	40M/327	Bearing	1
9	40M/325	Spacer, Bearing	1
10	40M/148	Circlip	2
11	USF11	Screw, Bearing Retaining	3
12	40M/299	Clip, Layshaft Bearing	2
13	40M/146	Bearing, Rear Layshaft	1
14	40M/130	Spacer, Bearing	1
15	40M/114	Gear, Reverse Speed	2
16	40M/118	Layshaft	1
17	USF21	Screw, Top Cover & Lock Strip	13
18	40M/136	Strip, Locking (Selector)	1
19	40M/116	Gear, Second Speed Sliding	1
20	40M/135	Shaft, Selector	2
21	CP1077	Ball, Detent	2
22	CM2103	Spring, Detent	2
23	40M/501	Fork, Selector (First & Reverse)	1
24	40M/502	Fork, Selector (Second & Third)	1
25	CM2053	Circlip, Primary Shaft	3
26	40M/360	Gear, First Reduction	1
27	40M162	Bush, Layshaft	1
28	40M/505	Plate, Interlock	1
29	40M/231	Stud, Interlock	2
30	CM2113	Disc, Sealing	3
31	40M/244	Split Pin, Interlock	2
32	40M/232	Clevis Pin, Interlock	2
33	40M/119	Shaft, Reverse Pinion	1
34	40M/222	Key, Reverse Pinion Shaft	1
35	40M/161	Bush, Reverse Pinion	1
36	40M/111 S/A	Pinion, Reverse C/W Item 35	1
37	40M/155	Washer, Reverse Pinion Shaft	1
38	CP1004	Pin, Split	1
39	UN507	Nut, Reverse Spindle	1
40	40M/346	Roller, Needle	1
41	40M/347	Circlip	2
42	40M/349	Gear, Drive	1
43	CP1002	Plug, Drain	2
44	CP1068	Washer, Drain Plugs & Dipstick	3
45	40M/348	Circlip	1
46	40M/174	Spacer, Bearing	2
47	CM2052	Bearing, Rear Mainshaft	2
48	40M/110	Gear, Output	1
49	40M/128	Spacer, Output Shaft	1
50	40M/113	Gear, Second Speed	1
51	40M/516	Shaft, Main	1

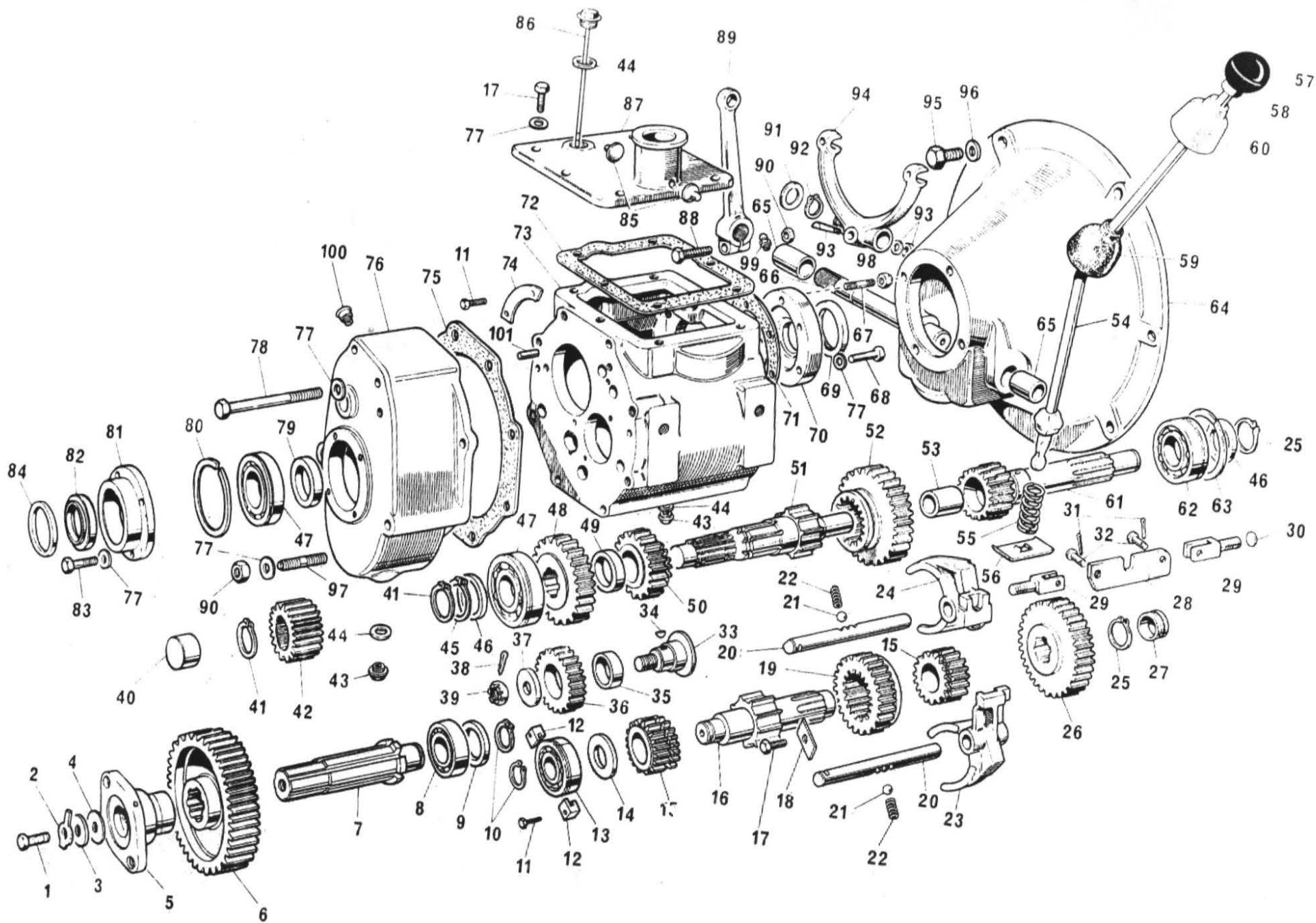

GEARBOX 40M/824 WITH 40M/372 GEAR LEVER Cont'd.

<i>Item No.</i>	<i>Part No.</i>	<i>Description</i>	<i>No. Off</i>
52	40M/115	Gear, First Speed	1
53	40M/513	Bearing, Primary Shaft	1
54	40M/372	Lever, Gear	1
55	40M/367	Spring, Gear Lever	1
56	40M/245	Plate, Gear Lever Retaining	1
57	40M/133	Knob, Gear Lever	1
58	UN512	Nut, Gear Lever	1
59	40M/129	Cover, Gear Lever	1
60	40M/377	Cover, Protective	1
61	40M/117 S/A	Shaft, Primary C/W Item 53	1
62	40M/143	Bearing, Input	1
63	40M/252	Ring, Snap	1
64	40M/392	Housing, Clutch	1
65	CM2179	Bush, Clutch Cross Shaft	2
66	40M/394	Cross Shaft, Clutch	1
67	40M/177	Stud	6
68	UBF71	Bolt, Front Cover	4
69	40M/150	Oil Seal, Input	1
70	40M/126	Cover, Front	1
71	40M/172	Joint, Front Cover	1
72	40M/169	Joint, Top Cover	1
73	40M/101/H	Casing, Gearbox	1
74	40M/141A	Retainer, Large Bearing	1
75	40M/626	Joint, Reduction Housing	1
76	40M/312	Housing, Reduction	1
77	W104	Washer, Front Cover, Top Cover Lock Strip & Reduction Housing	25
78	UBF191	Bolt, Reduction	4
79	40M/320	Spacer, Output Shaft	1
80	CM2060	Retainer, Bearing	1
81	40M/622 S/A	Housing, Rear Oil Seal C/W Item 82	1
82	40M/167	Oil Seal, Rear	1
83	USF31	Screw Reduction Housing	8
84	CM2201	Excluder, Dust	2
85	40M/254	Pad, Gear Lever	2
86	40M/153	Dipstick	1
87	40M/220	Cover, Gearbox	1
88	UBF91	Bolt, Clutch Lever	1
89	CM2090	Lever Clutch Release	1
90	UN501	Nut, Clutch Lever & Reduction Housing	3
91	40M/398	Washer, Cross Shaft	1
92	CP1006	Circlip, Cross Shaft	1
93	CM2084/SA	Cotter, Nut & Washer	1
94	CM2083	Fork, Clutch Release	1
95	C191	Bolt, Clutch Assy.	6
96	C192	Washer, Clutch Assy.	6
97	40M/329	Stud	2
98	UNL106	Nut, Clutch Housing	6
99	CP1069	Nipple, Grease (Straight)	1
100	CM2106	Breather	1
101	40M/359	Dowel	1

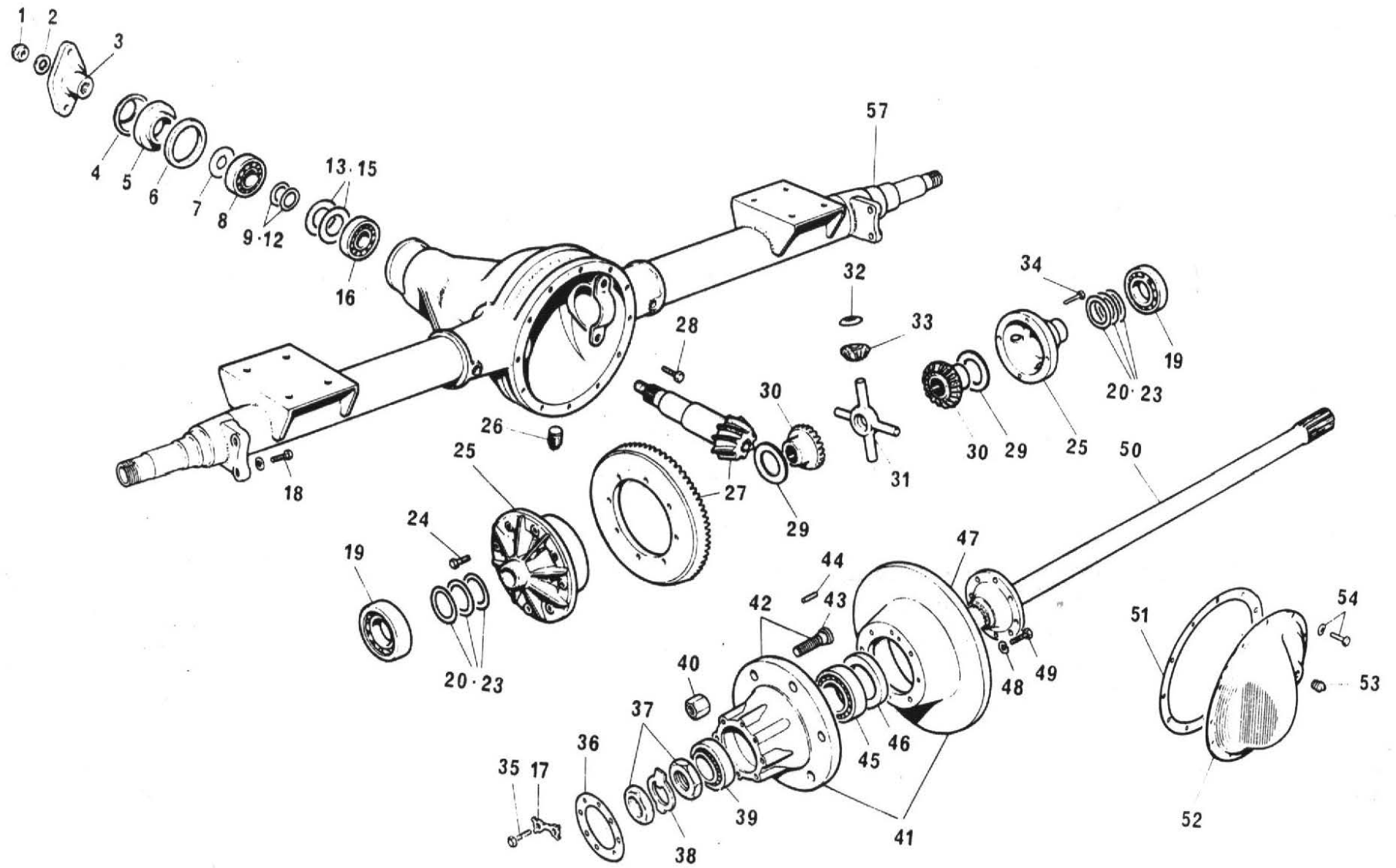

**DRIVE AXLE (5HA-001-162D & WHEEL ASSEMBLY
DRIVE AXLE (5HA-001-239) & WHEEL ASSEMBLY FROM SERIAL NO. N70/546**

<i>Item No.</i>	<i>Part No.</i>	<i>Description</i>	<i>No. Of</i>
1	12LN-NF9	Pinion Nut	1
2	12W-24	Pinion Nut Washer	1
3	5HA-102-8	Companion Flange Assembly Type 70 4.5/16" Ctrs.	1
4	2HA-021	Companion Flange Dust Shield	1
5	2HA-019	Pinion Oil Seal	1
6	2HA-020	Pinion Oil Seal Gasket	1
7	2HA-036	Pinion Oil Slinger	1
8	5HA-022	Pinion Bearing Outer	1
9	5HA-039	Pinion Adjusting Shim Outer (.003") as req'd	2
10	5HA-040	Pinion Adjusting Shim Outer (.005") as req'd	2
11	5HA-041	Pinion Adjusting Shim Outer (.010") as req'd	2
12	5HA-042	Pinion Adjusting Shim Outer (.030") as req'd	2
13	5HA-043	Pinion Adjusting Shim Inner (.003") as req'd	2
14	5HA-044	Pinion Adjusting Shim Inner (.005") as req'd	2
15	5HA-045	Pinion Adjusting Shim Inner (.010") as req'd	2
16	5HA-023	Pinion Bearing Inner	1
17	5HA-074-3	Axle Shaft Flange Lockstrap	8
18	7BNF-22-B	Brake Caliper Mounting Bolt	4
18A	7W-16	Caliper Mounting Packing Washer	4
18B	7W-14	Caliper Mounting Washer	4
18C	5HA-138	Caliper Adjusting Shim (.003")	A/R
18D	5HA-139	Caliper Adjusting Shim (.005")	A/R
18E	5HA-140	Caliper Adjusting Shim (.020")	A/R
18F	5HA-141	Caliper Adjusting Shim (.030")	A/R
19	5HA-024-1	Differential Bearing	2
20	5HA-046	Differential Bearing Shim (.003")	2
21	5HA-047	Differential Bearing Shim (.005")	2
22	5HA-048	Differential Bearing Shim (.010")	2
23	5HA-049	Differential Bearing Shim (.030")	2
24	5HA-075-2	Drive Gear Screw	12
25	5HA-006-1	Differential Case	1
	* 5HA-082-2	Differential Case Assembly	1
	* 5HA-082-11	Differential Case Assembly (From Serial No. N70/546)	1
26	HA-059	Drain & Filler Plugs	2
27	5HA-105-11	Drive Gear and Pinion Assembly including Items 1, 24 & 58	1
28	8BNC.36	Differential Bearing Cap Screw	4
28A	8LW-115	Differential Bearing Cap Lockwasher	4
29	5HA-038-1	Differential Case Side Gear Thrustwasher	2
30	5HA-007-4	Differential Side Gear	4
	5HA-007-3	Differential Side Gear (from Serial No. N70/546)	4
31	5HA-012-2	Differential Pinion Mate Shaft	1
32	5HA-037-1	Pinion Mate Thrustwasher	4
33	5HA-008-4	Pinion Mate	2
	5HA-008-3	Pinion Mate (from Serial No. N70/546)	2
34	5BNC2 BA	Differential Case Screw	8
34A	5HA-097	Differential Case Lockstrap	4
35	7BNC-20A	Axle Shaft Flange Driving Bolt	16
36	10HA-031	Axle Shaft Flange Gasket	2
37	32N-NF4	Wheel Bearing Locknut	4
38	8HA-091-2	Wheel Bearing Locking Washer	2
39	8HA-025-6	Wheel Bearing Outer	2
40	T.23	Wheel Nut	12
41	10HA-028-23	Hub and Disc Assembly	2
42	10HA-028-24	Wheel Hub with Studs	2

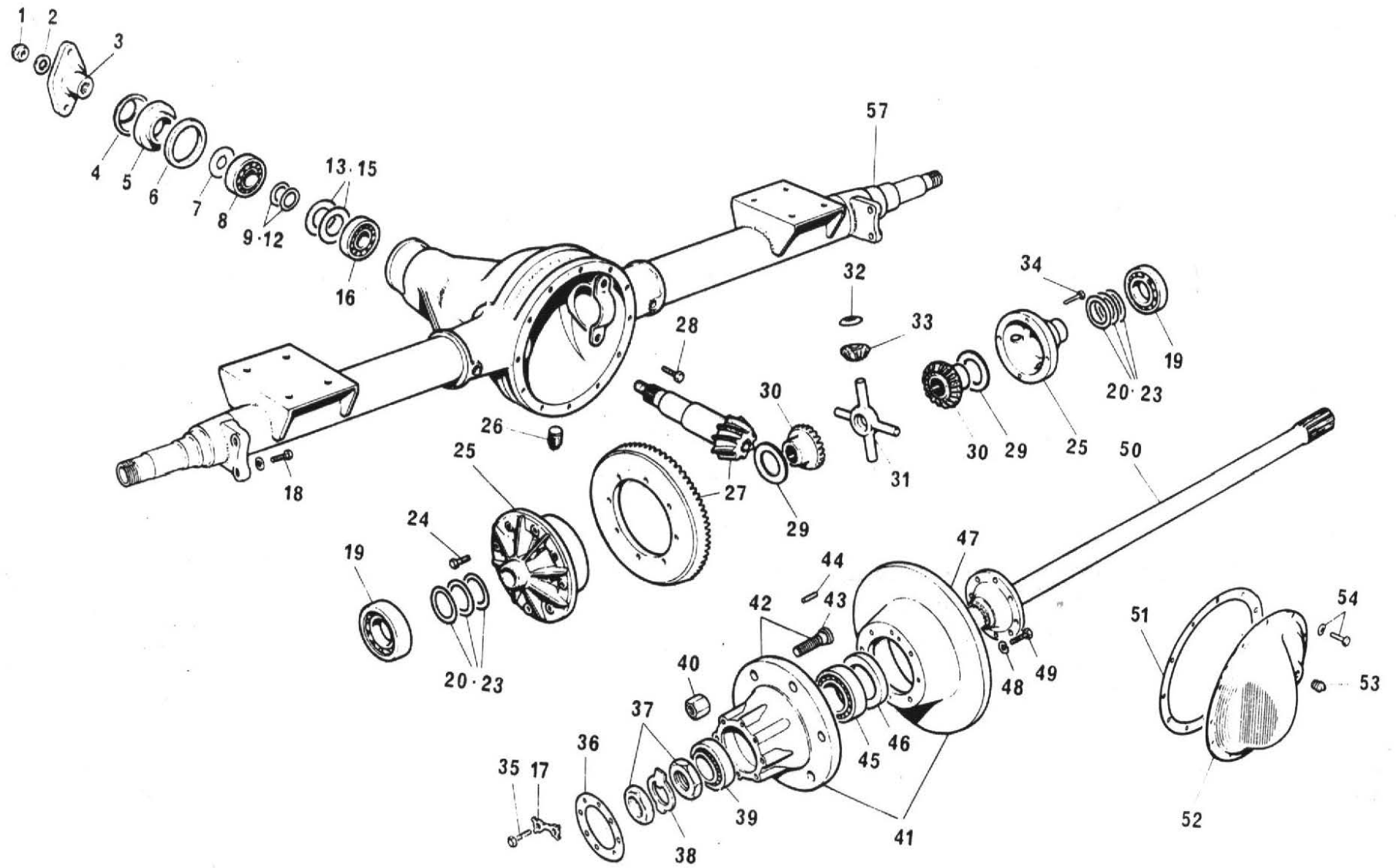

DRIVE AXLE Cont'd

<i>Item No.</i>	<i>Part No.</i>	<i>Description</i>	<i>Qty</i>
43	10HA-055-5	Wheel Stud	12
44	12RP-16	Brake Disc Dowel	4
45	8HA-025-5	Wheel Bearing Inner	2
46	5HA-032-6	Hub Oil Seal	2
47	10HA-136	Brake Disc	2
48	6LW-105	Brake Disc Retaining Washer	10
49	6BNF-21	Brake Disc Retaining Screw	10
50	5HA-005-75	Axle Shaft	2
51	5HA-026	Gear Carrier Cover Gasket	1
52	5HA-010-14	Gear Carrier Cover	1
53	HA-059	Filler Plug	1
54	6B-NC-10	Cover Screw and Washer	10
57	5HA-101-86	CARRIER TUBE	1

7819

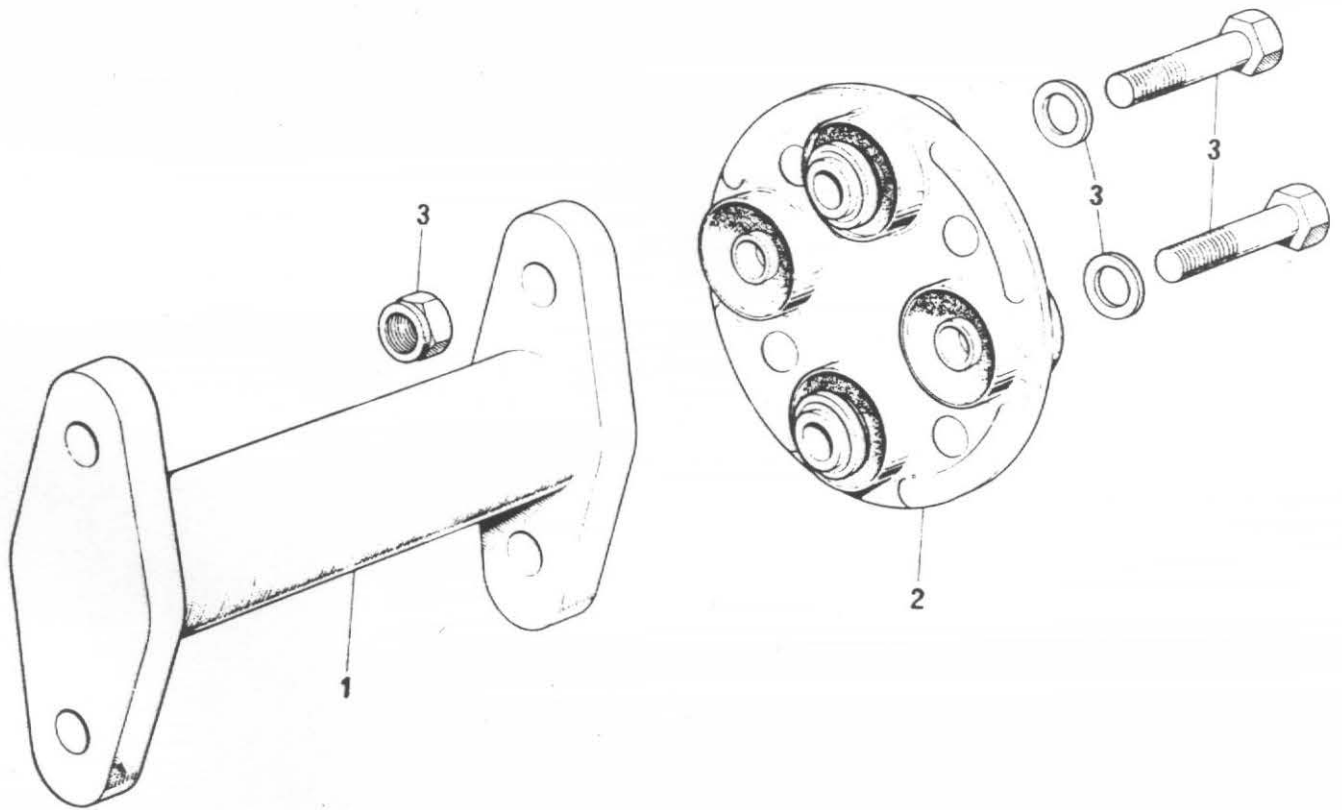

PROPSHAFT

Item No.	Part No.	Description	Qty.
1	5S10270	Prop shaft tube (9/16" bolts, 4. 5/16" centers)	1
1	5S102/65	Prop shaft tube (alternative)	1
2	10323A01	Coupling	2
3	10203A	Coupling bolt, washer and nut (9/16")	8

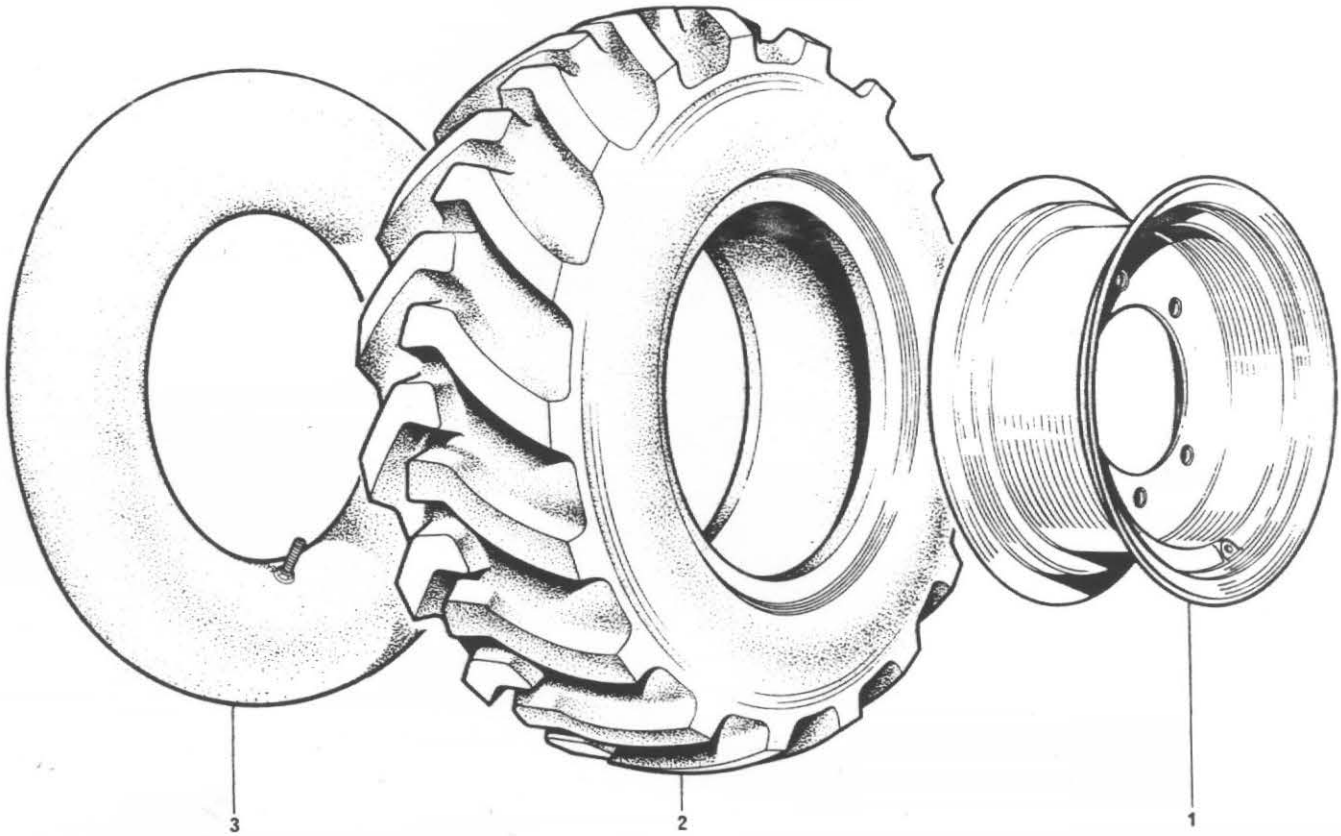

DRIVE WHEELS AND TYRES

Item No.	Part No.	Description	Qty.
	24S16	R/H Wheel Assembly	1
	24S15	L/H Wheel Assembly	1
1	30193A01	Wheel rim 9 x 18	2
2	20S01	Tyre 10.5 x 18-6 ply	2
3	23S04	Tube 10.5 x 18	2

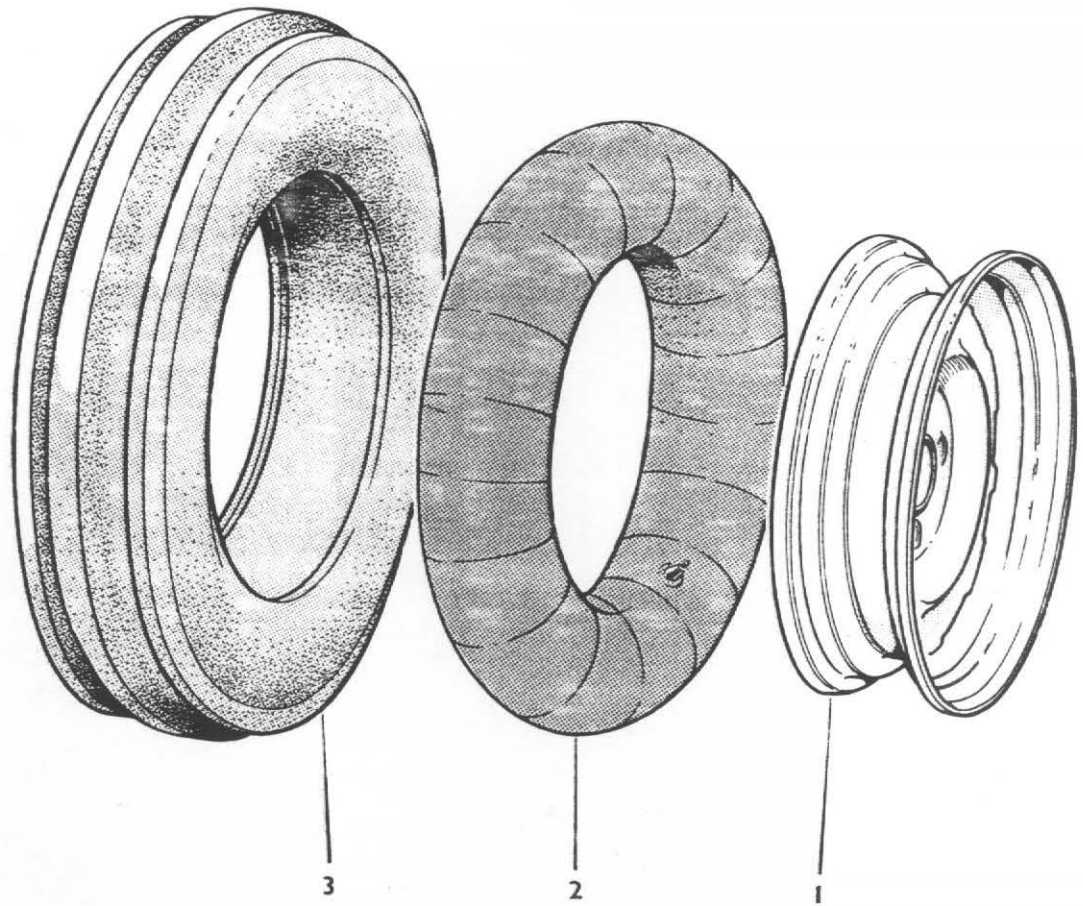

STEERING WHEELS AND TYRES

Item No.	Part No.	Description	Qty.
1	24S31	Steering wheel complete	2
2	30033A01	Wheel rim 4.00 x 16	2
2	23S02	Tube 6.00 x 16	2
3	21S03	Tyre 6.00 x 16-4 ply	2

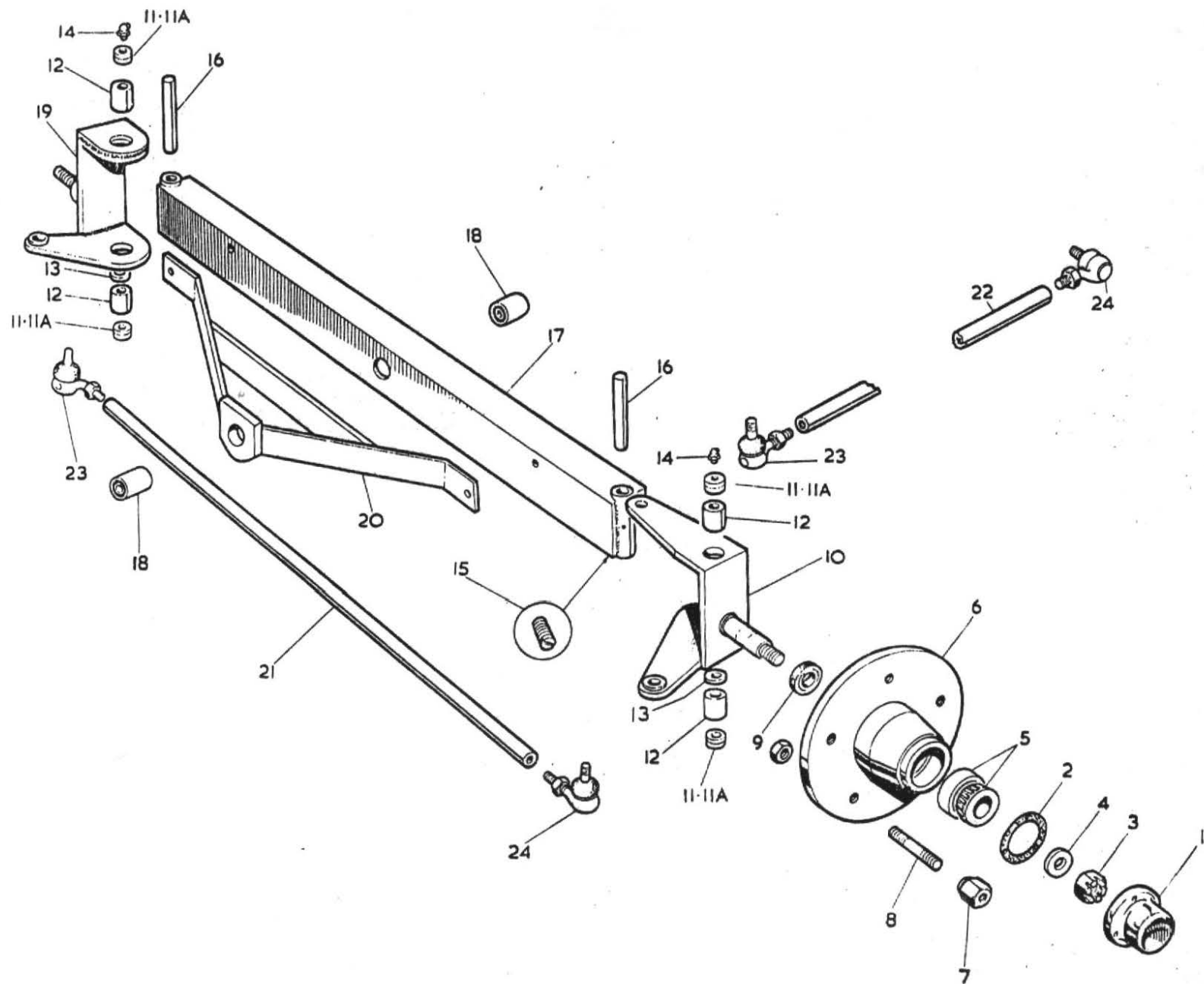

STEERING AXLE

<i>Item No.</i>	<i>Part No.</i>	<i>Description</i>	<i>No. Off</i>
1	R/344	Hub Cap	2
2	R/345	Hub Cap Gasket	2
3	R.305/A	Hub Nut	2
4	R.305/B	Hub Nut Washer	2
5	K.18690	Hub Bearing (Inner and Outer)	4
6	0190	Hub Assembly	2
7	10668.A01	Hub Wheel Nut	10
8	0190/S	Wheel Stud	10
9	R.343	Hub Bearing Oil Seal	2
10	F.505/OS	Stub Axle Assembly O/S	1
11	C.180 A & B	King Pin End Cap (Felt and Steel)	4
12	C.190	King Pin Bush	4
13	C.175	Thrust Washer	2
14	T.90	Grease Nipple	2
15	C111/A	King Pin Retaining Screw	2
16	R.320	King Pin	2
17	F.503	Steering Axle Beam	1
18	E.2245	Steering Axle and Stabiliser Bush	2
19	F.505/NS	Stub Axle Assembly N/S	1
20	L.262	Steering Axle Stabiliser	1
21	L 308	Track Rod	1
22	F.513	Drag Link	1
23	C.159/LH	Track Rod and Drag Link End L.H.	2
24	C.159/RH	Track Rod and Drag Link End R.H.	2

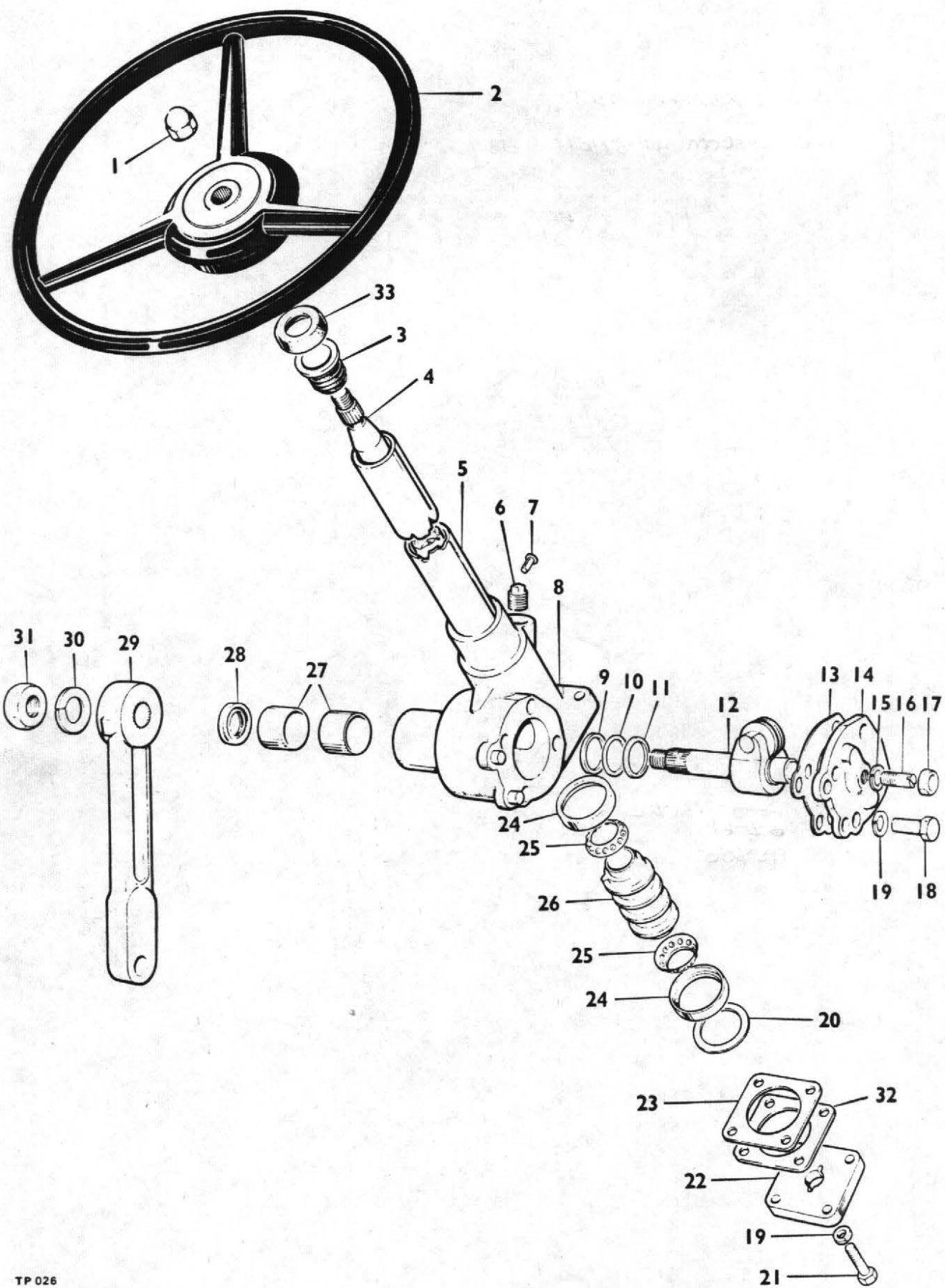

STEERING GEAR (CAM AND ROLLER TYPE)

Item No.	Part No.	Description	Qty.
	MGA 34849	Steering column assy. complete less items, 1,2 & 29	1
1	C 304	Steering wheel nut	1
2	347 K	Steering wheel	1
3	PA3904A	Column top bush	1
4	P5244/30"	Inner shaft	1
5	P3911/24"	Outer tube	1
6	S 9033	Oil plug	1
7	S 9166	Pin	1
8	PA4426	Steering box c/w item 14	1
9	P4151	Thrust washer	2
10	P 3308	Shim	A/R
11	P 4150	Thrust washer	2
12	PA5229/4¼"	Rocker shaft c/w roller	1
13	P3306A	Cover plate gasket	A/R
14	QA757	Cover plate and bush	1
15	S 999	Spring washer	1
16	P 4222	Adjuster screw	1
17	P 4221	Nut	1
18	S 9240	Setscrew	4
19	S 902	Spring washer	8
20	P3342	Washer	1
21	S 9300	Setscrew	4
22	P 3907	Bottom cap	1
23	P 3301/.005"	Shim	A/R
24	P 3341	Outer race	2
25	PA2733	Cage and balls	2
26	P 3340	Cam	1
27	P 3309	Bush	2
28	S 9242	Oil seal	1
29	M 29629	Drop arm	1
30	S 955	Spring washer	1
31	S 9332	Nut	1
32	P 3301G	Bottom cap liner	2
33	M33418	Inner column shroud	1

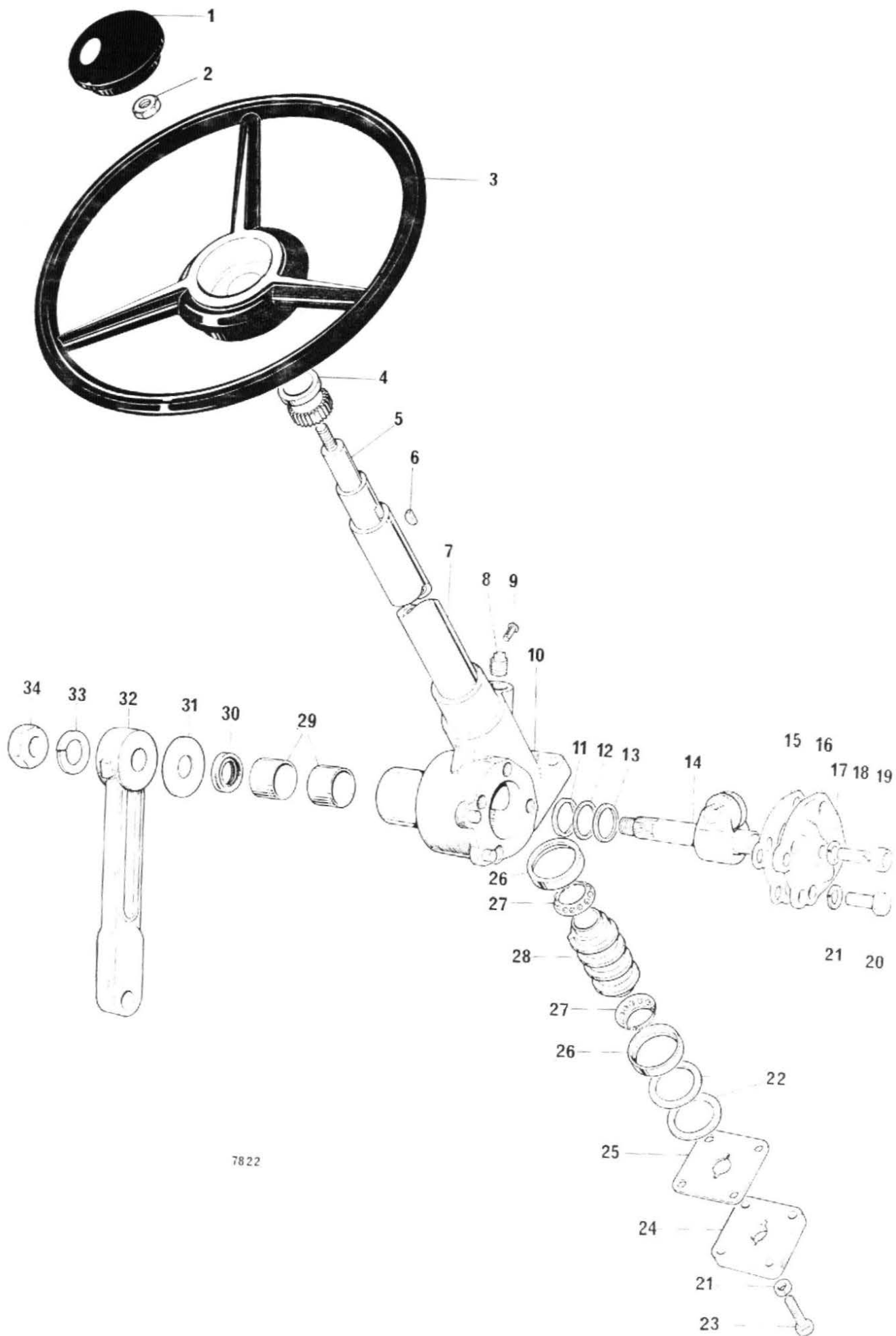

7822

STEERING GEAR

<i>Item No.</i>	<i>Part No.</i>	<i>Description</i>	<i>No. Off</i>
	562	Steering Column Assy. only Complete Less Items 1, 2, 3 & 32.	1
1	153A	Steering Wheel Cap	1
2	C197	Nut	1
3	153	Steering Wheel	1
4	PA3904A	Bush, Column Top	1
5	M24733	Inner Shaft	1
6	S9119	Woodruff Key (No. 9)	1
7	P3911/24.3/4"	Outer Tube	1
8	S9033	Oil Plug	1
9	S9166	Pin	1
10	P3689	Steering Box - BSF	1
10A	PA4425	Steering Box - UNF	1
11	P4151	Thrust Washer	1
12	P3308	Shim	A/R
13	P4150	Thrust Washer	1
14	PA5229/4.1/4"	Rocker Shaft	1
15	P3306A	Gasket	A/R
16	P3695	Cover Plate & Bush (BSF)	1
16A	QA757	Cover Plate & Bush (UNF)	1
17	S999	Spring Washer	1
18	P3202	Adjuster Screw (BSF)	1
18A	P4222	Adjuster Screw (UNF)	1
19	P3203	Nut (BSF)	1
19A	P4221	Nut (UNF)	1
20	S914	Bolt (BSF)	4
20A	S9240	Bolt (UNF)	4
21	S902	Spring Washer	8
22	P3342	Washer	2
23	S948	Bolt (BSF)	4
23A	S9300	Bolt (UNF)	4
24	S3907	Bottom Cap	1
25	P3301	Shim	A/R
26	P3341	Outer Race	2
27	PA2733	Cage & Balls	2
28	P3340	Cam	1
29	P3309	Bush	2
30	P2766	Oil Seal	1
31	P2743	Plug	1
32	M29629	Drop Arm	1
33	S955	Spring Washer	1
34	S9156	Nut	1

NOTE: Item 10A will be supplied C/W Items 20A, 23A & 29, and will replace Item 10.
Item 16A will be supplied C/W Items 18A & 19A, and will replace Item 16.

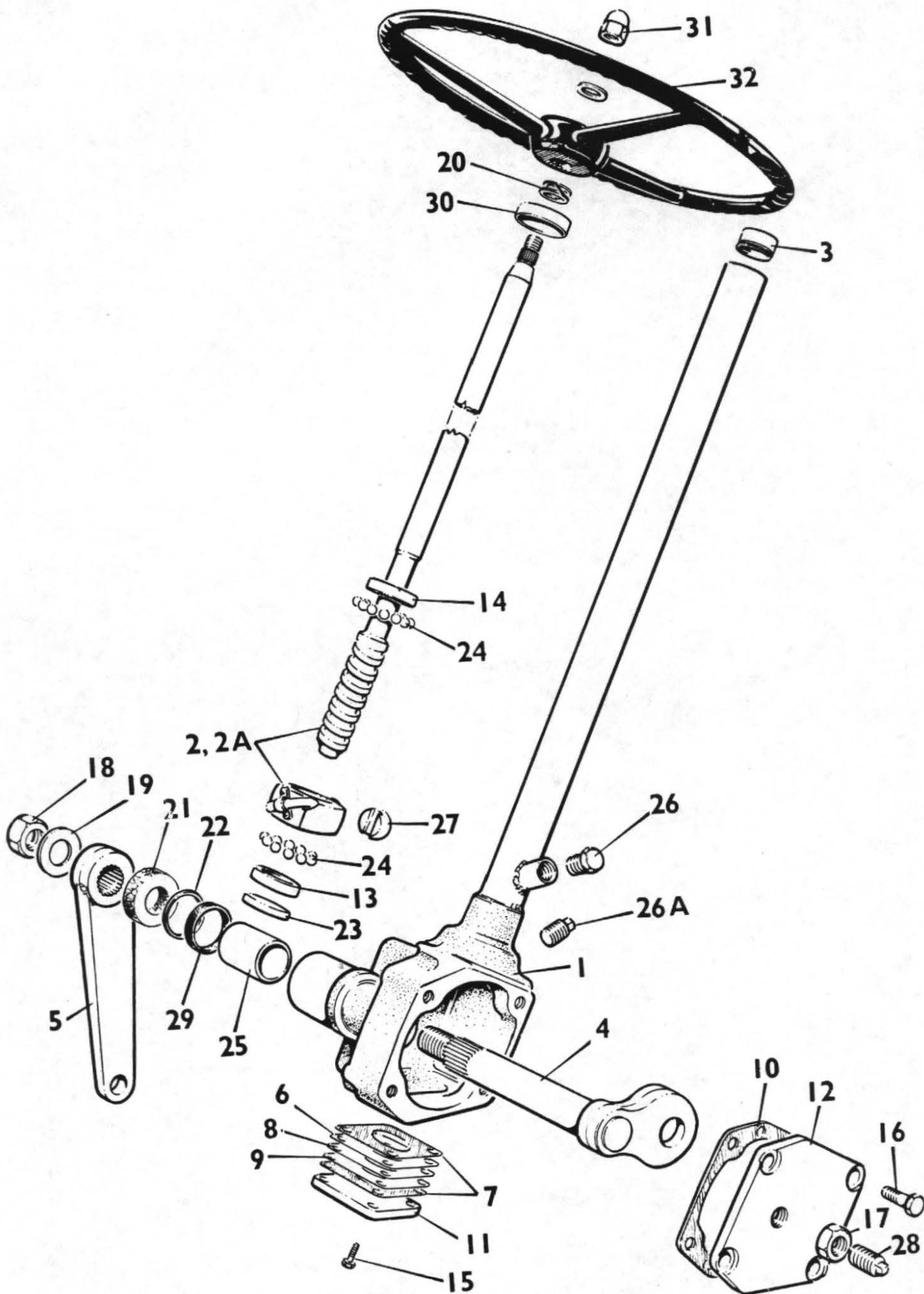

STEERING GEAR (RECIRCULATING BALL TYPE)

Item No	Part No.	Description	Qty
	11-077	Steering gear complete (less items 5 & 32)	
1	SA-01-183	Box and Tube assembly	1
2	SA-02-269	Inner column assembly and main nut (700mm long)	1
2A	SA-02-277	Inner column assembly and main nut (750mm long)	1
3	SA-21-004	Bearing assembly	1
4	S-7-103	Rocker shaft	1
5	2SE90	Drop arm	1
6	S-10-14	End plate shim .005"	3
7	S-10-15	End plate gasket	2
8	S-10-42	End plate shim .002"	2
9	S-10-111	End plate shim .010"	2
10	S-10-191	Cover plate gasket	1
11	S-11-83	End plate	1
12	S-12-186	Cover plate	1
13	S-23-32	Ballrace (small)	1
14	S-23-33	Ballrace (large)	1
15	10-3-37	End Plate bolt	4
16	10-4-16	Cover Plate bolt	4
17	11-7-2	Rocker shaft adjuster screw nut	1
18	11-8-7	Rocker shaft nut	1
19	12-8-36	Rocker shaft tab washer	1
20	12-8-85	Spring	1
21	12-9-61	Drop arm felt washer	1
22	12-10-7	Oil seal retaining washer	1
23	12-12-26	Inner column packing plate	1
24	17-3-4	Steel ball	54
25	19-9-17	Rocker shaft bush	1
26	21-8-4	Oil Plug	1
26A	21-7-2	Oil Plug	1
27	24-5-5	Main nut roller	1
28	25-7-2	Rocker shaft adjuster screw	1
29	27-9-6	Oil seal	1
30	32-8-8	Dust cap	1
31	11-7-45	Dome nut	1
32	347K	Steering wheel	1

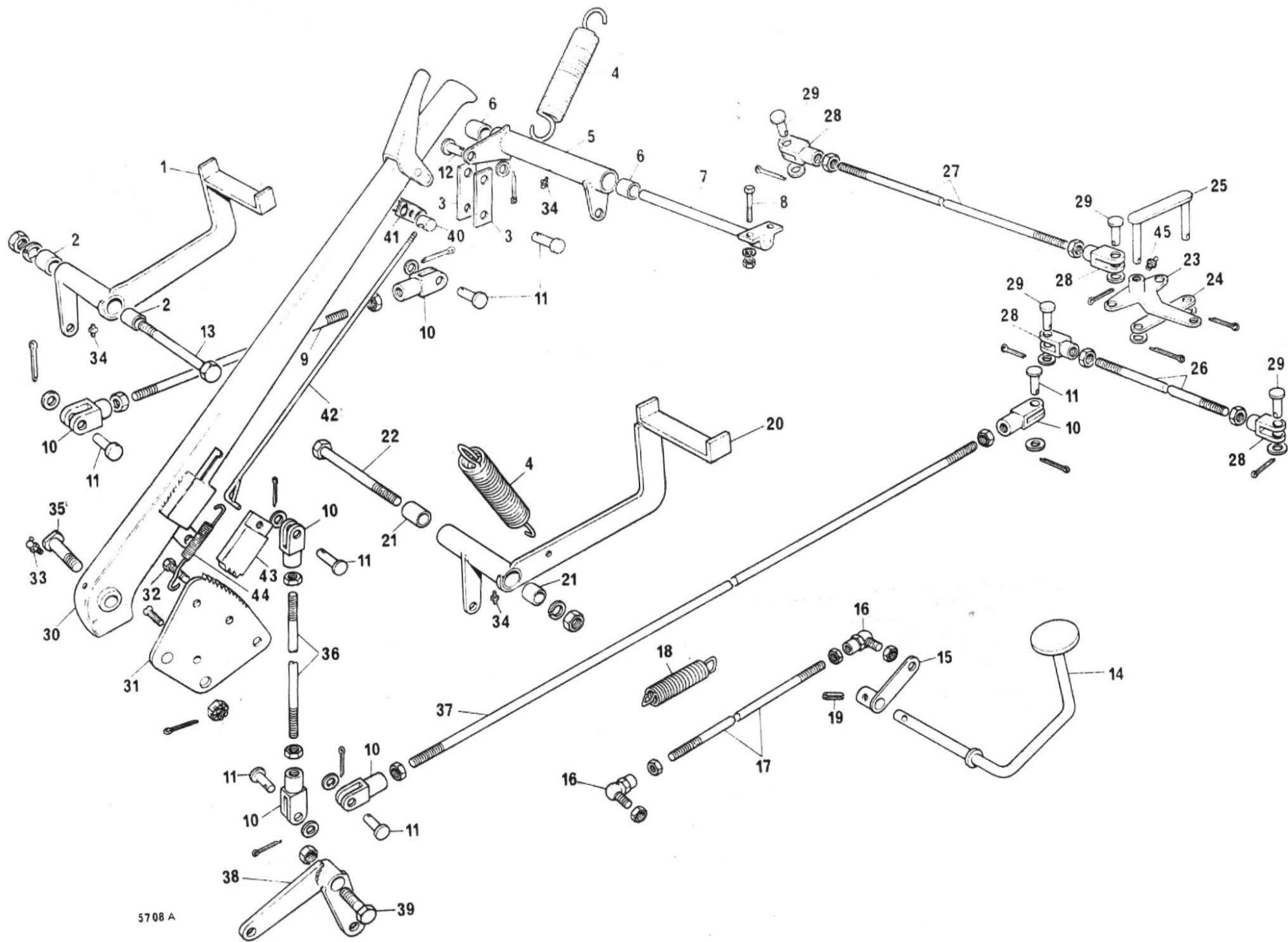

5708 A

CLUTCH, HANDBRAKE & FOOTBRAKE ASSEMBLIES

<i>Item No.</i>	<i>Part No.</i>	<i>Description</i>	<i>No. Of</i>
1	F521	Pedal, Clutch	1
2	WB.1010	Bush, Clutch Pedal	2
3	F537	Link, Clutch Lever	2
4	C173-B	Spring, Return (Clutch and Footbrake Pedal)	2
5	F519	Lever, Clutch Transfer	1
6	WB0808	Bush, Transfer Lever	2
7	F519A	Rod, Clutch Transfer Lever	1
8		Nut and Bolt, 3/8" BSF x 1.1/4" Long	1
9	F525	Rod, Clutch Adjusting 14.1/2" x 3/8" BSF	1
10	C174 A	Clevis	6
11	C174 X	Clevis Pin	7
12	5ST-101	Clevis Pin	1
13		Nut and Bolt, 5/8" BSF x 4.1/2" Long	1
14	C137	Pedal, Accelerator	1
15	F522	Lever, Accelerator	1
16	C160-B	Ball End, Accelerator Rod	2
17	F524	Rod, Accelerator	1
18	C173-D	Spring, Return (Accelerator Rod)	1
19	C129A	Pin, Tension	1
20	4S.102	Pedal, Footbrake	1
21	WB1212	Bush, Footbrake Pedal	2
22		Nut and Bolt 3/4" BSF x 8" Long	1
23	5ST76	Arm, Compensator Lever	1
24	C189-A	Link, Compensator	1
25	C271	Compensator Link Assembly	1
26	L278A	Rod, Brake	1
27	4S.107	Rod, Brake	1
28	C174-C	Forkend	4
29	C174-Y	Clevis Pin	4
30	F517	Handbrake Lever Complete	1
31	F517A	Quadrant, Handbrake Lever	1
32		Bolt, 5/16" BSF x 1" Long	2
33	T90	Nipple, Grease (90°)	1
34	T/ST	Nipple, Grease (Straight)	3
35	F517B	Bolt, Handbrake Carrier	1
36	F506B	Rod, Lever Connecting	1
37	4S.108	Rod, Handbrake	1
38	LT292	Lever, Handbrake Transfer	1
39		Nut and Bolt, 5/8" BSF x 3.1/4" Long	1
40	000022/A	Pin, Latch Pivot Arm	1
41	14425A	Arm, Latch Pivot	1
42	10291C	Rod, Handbrake Rod	1
43	6266A	Pawl, Handbrake Pawl	1
44	12873 A	Spring, Handbrake	1
45	5ST100	Grease Nipple	1

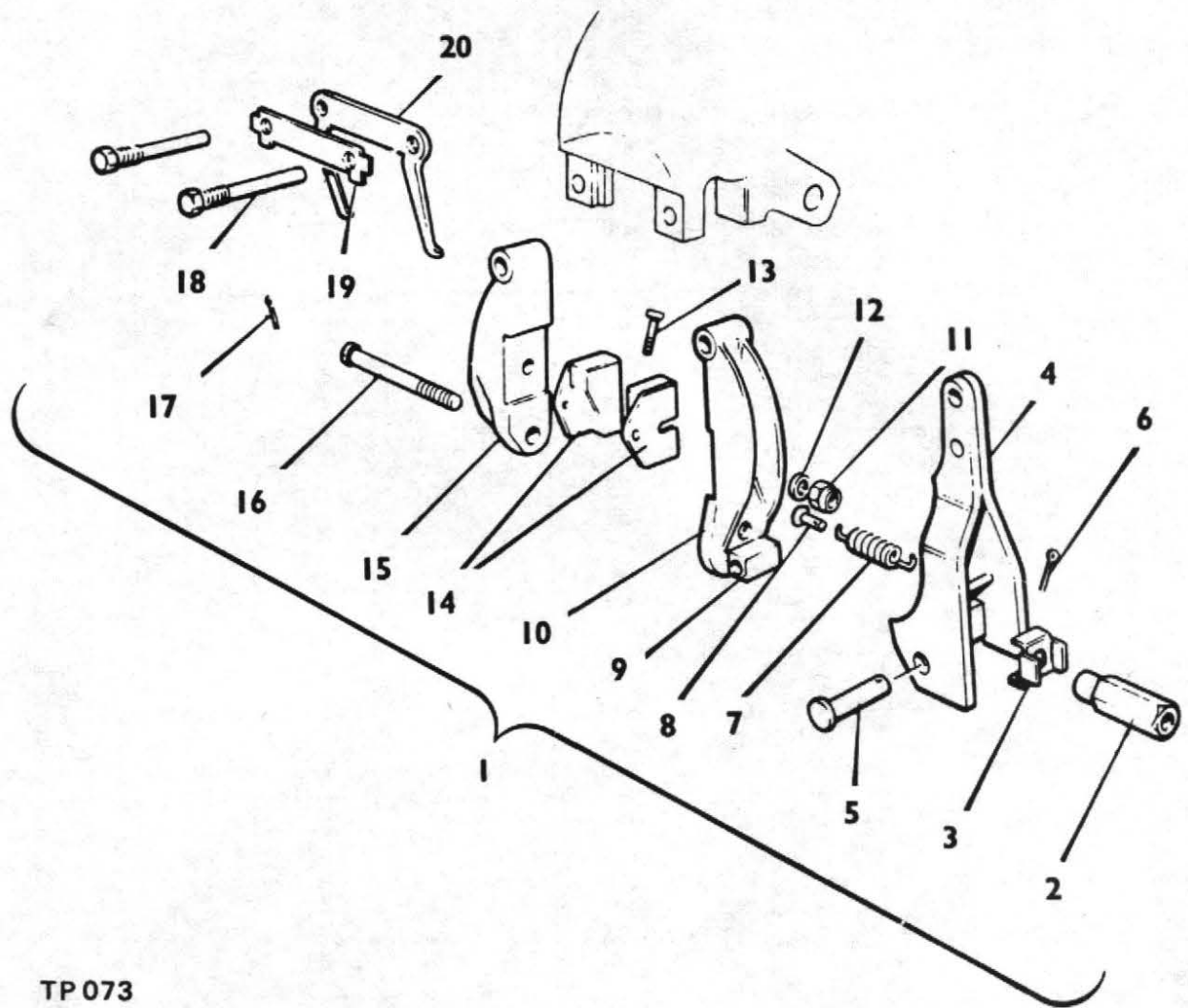

TP 073

HANDBRAKE ASSEMBLY

Item No.	Part No.	Description	Qty
1	CB 90256	Handbrake Assembly complete RH	1
	CB 90257	Handbrake Assembly complete LH	1
2	CB 20258	Adjustment Nut	1
3	VBO 8307	Friction Spring	1
4	CB 20562	Lever Assembly	1
5	VBO 8315	Hinge Pin	1
6	VBO 6135 D	Split Pin	1
7	VBO 7329	Return Spring	1
8	VBO 7330	Spring Anchor	1
9	VBO 8308	Pivot Seat	1
10	CB 60249 8308	Pad Carrier Assembly Inner Complete with Pivot Seat	1
11	VBO 6050	Nut 2 B.A.	2
12	VBO 6101F	Washer	2
13	VBO 4124	Bolt	2
14	CB 20311Y	Friction Pad	2
15	VBM 4573	Pad Carrier Outer	1
16	CB 20289	Bolt	1
17	VBO 6158G	Split Pin	1
18	VBO 4190	Bolt	2
19	VBO 4226	Tab Washer	1
20	VBM 4635/1	Retraction Plate	1

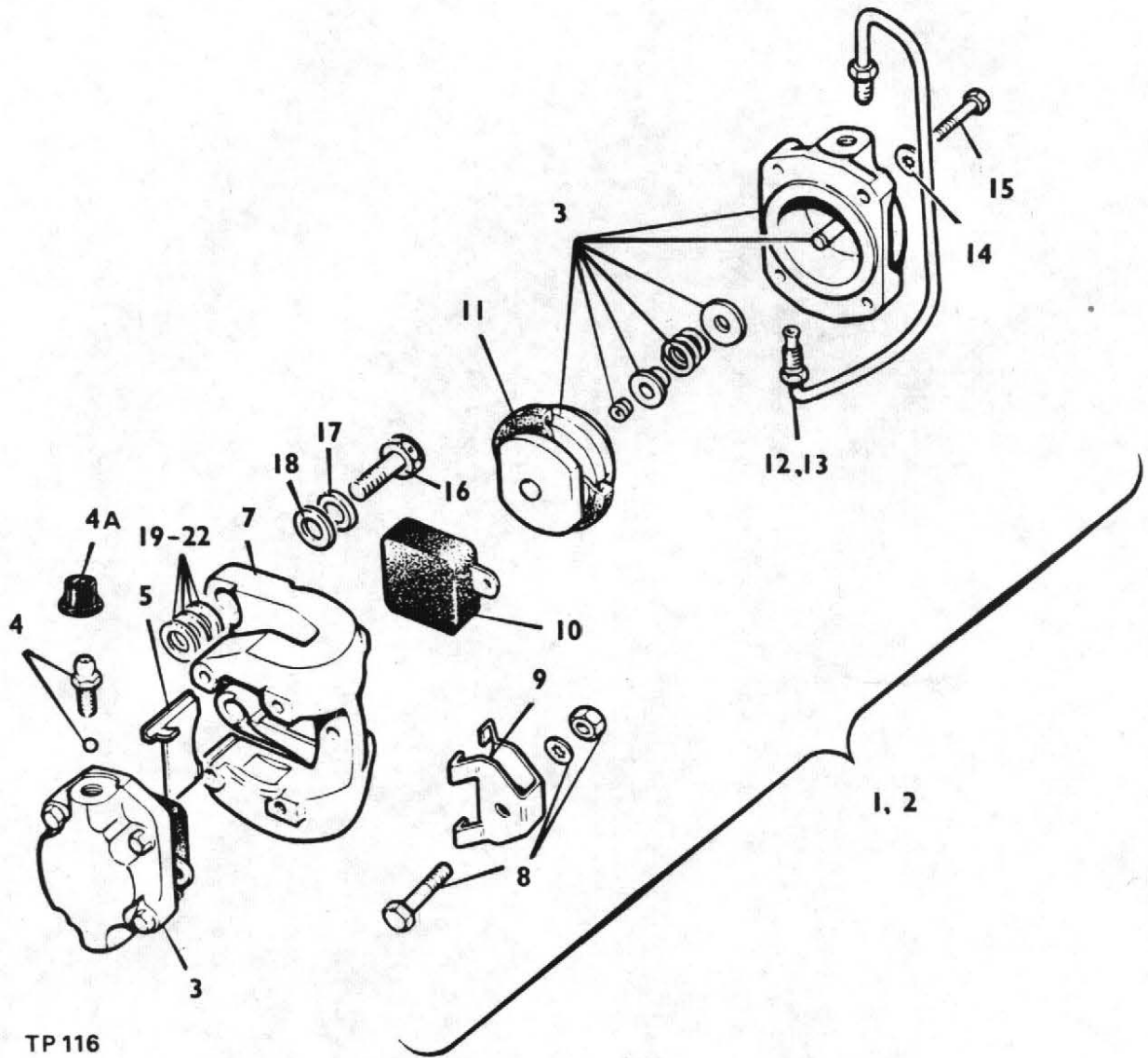

TP 116

BRAKE CALIPER ASSEMBLY

Item No.	Part No.	Description	Qty
1	CB 90262	Capliper Assembly Complete (RH)	1
2	CB 90263	Capliper Assembly Complete (LH)	1
3	VBO 5505	Piston and Cylinder Assembly	2
4	VBO 8378	Bleed Screw and Ball Assembly	1
4A	CBO 849	Dust Cover (Bleedscrew)	1
5	VBO 5133	Plate, Support	1
6	CB 60253	Body, Caliper (LH)	1
7	CB 60252	Body, Caliper (RH)	1
8	VBO 8491	Nut, Bolt and Washer (Keep Plate)	1
9	VBO 5123	Keep Plate	1
10	VBO 8360Y	Friction Pad Complete (Set of 4)	1 set
11	VBO 8210A	Seal Kit (Dust & Piston)	2
12	VBO 3927	Bridge Pipe Assembly (LH)	1
13	VBO 3926	Bridge Pipe Assembly (RH)	1
14	VBO 6101L	Washer, Shakeproof	8
15	VBO 5100	Bolt, Retaining (Cylinder)	8
16	7BNF22B	Caliper mounting bolt	4
17	7W16	Washer	4
18	7W14	Washer	4
19	5HA138	Shim .003"	A/R
20	5HA139	Shim .005"	A/R
21	5HA140	Shim .010"	A/R
22	5HA141	Shim .030"	A/R

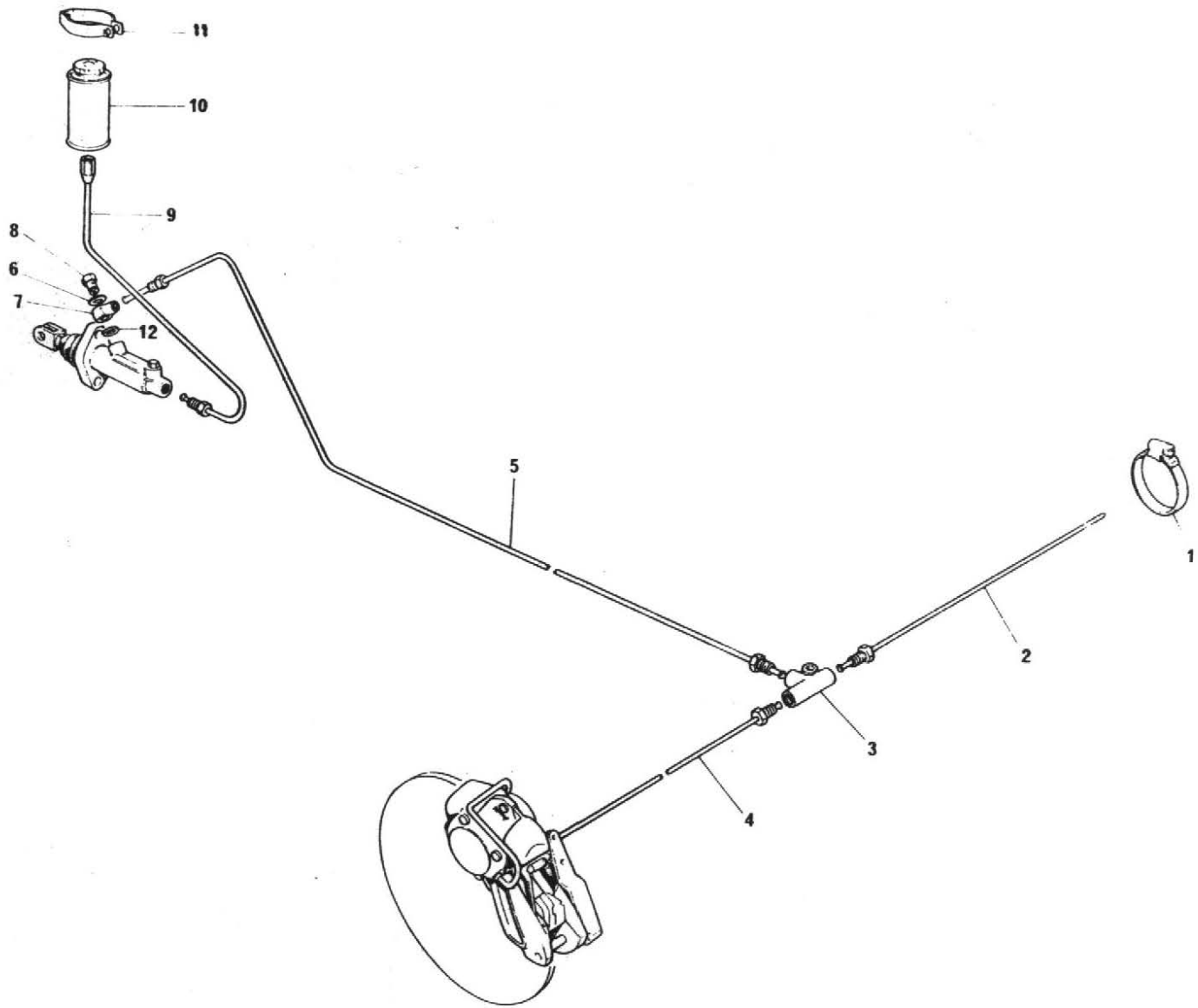

HYDBAULIC BRAKE SYSTEM

<i>Item No.</i>	<i>Part No.</i>	<i>Description</i>	<i>No. Off</i>
1	4-3505	Hose Clip	2
2	3508610W	Pipe (43")	1
3	64474341	Tee Piece	1
4	64476097	Pipe (18.1/2")	1
5	64474263	Pipe (53")	1
6	378700	Washer	1
7	64474287	Banjo	1
8	376102W	Banjo Bolt	1
9	3424240W	Pipe (21")	1
10	64047211	Header Tank	1
11	378620	Clip	1
12	378703	Washer	1

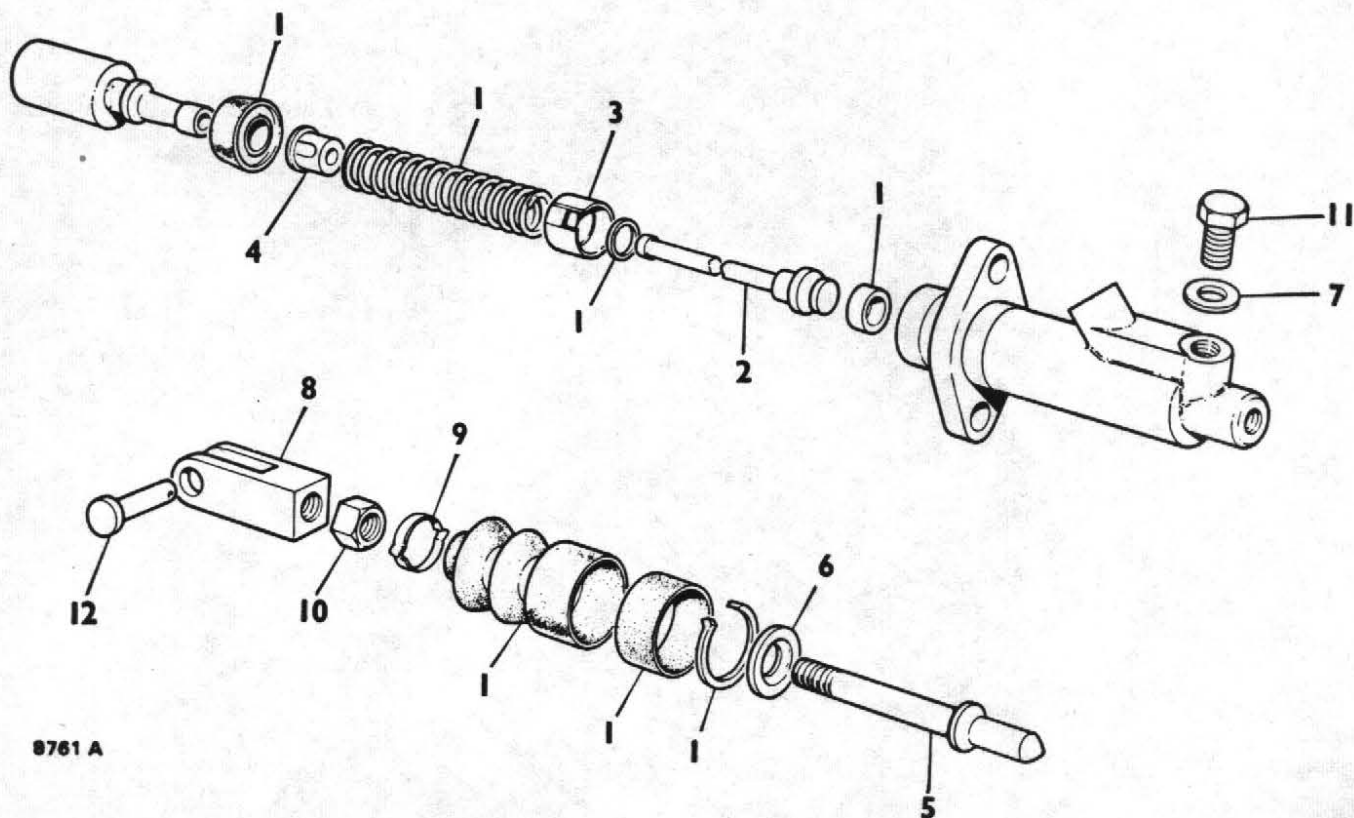

8761 A

MASTER CYLINDER ASSEMBLY

Item No.	Part No.	Description	Qty.
	64067970	Master Cylinder (Complete)	1
1	SP 1996/2	Seal Kit	1
2	378641	Valve Stem	1
3	318001	Valve Spacer	1
4	64673391	Valve Spring Retainer	1
5	351257 W	Push Rod	1
6	378242	Retaining Washer	1
7	378700	Washer	1
8	64671286	Clevis	1
9	378312	Dust Cover Retainer	1
10	64100052	Locknut	1
11	64110348	Plug	1
12	C174 Y	Clevis Pin	1

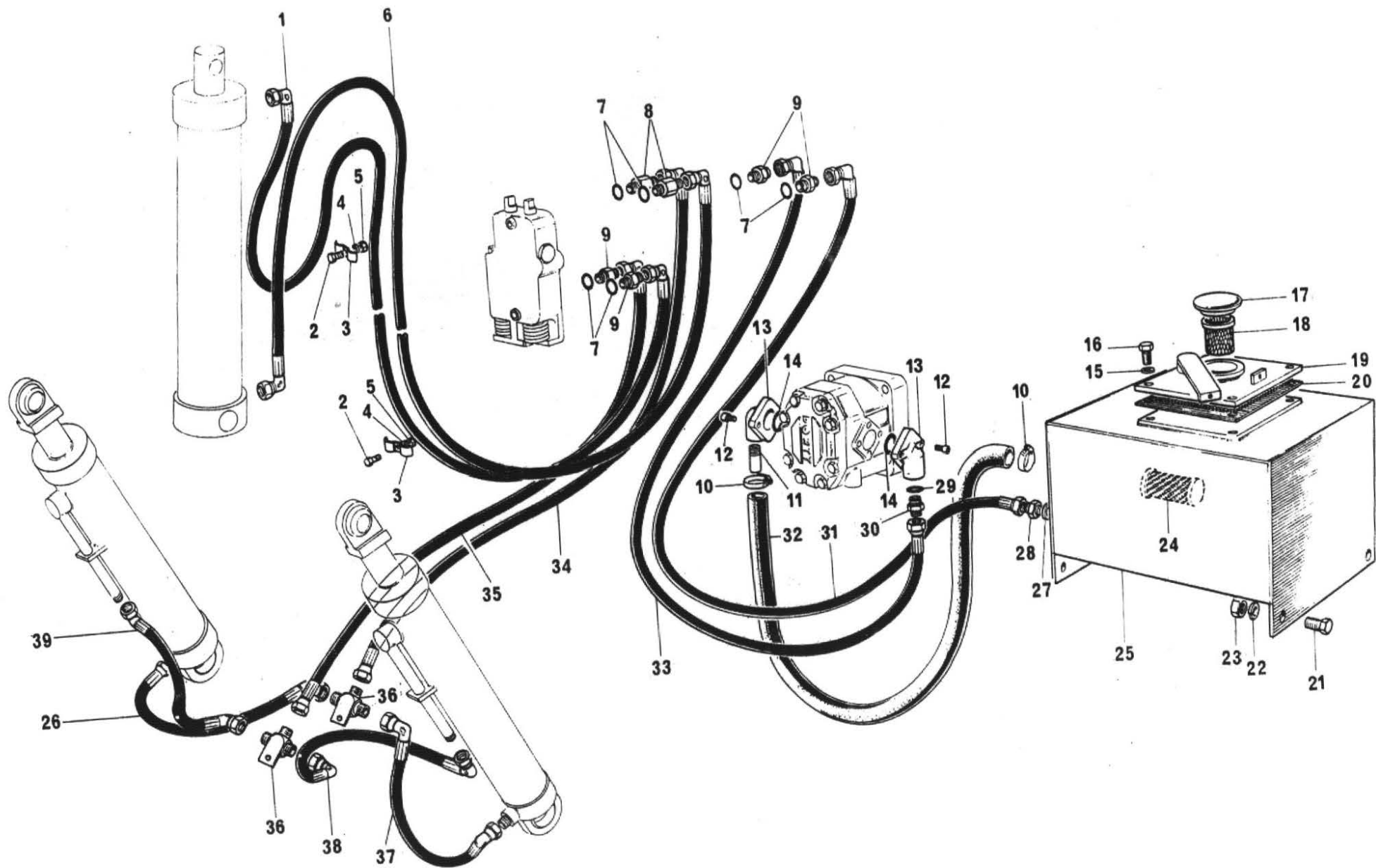

HYDRAULICS

<i>Item No.</i>	<i>Part No.</i>	<i>Description</i>	<i>No. Off</i>
1	4SHI 87	Hose - Valve to Ram Head 3/8" x 100" x 90°/90°	1
2		Bolt 1/4" UNF x 1" Long	2
3	X81	Pipe Clamp	2
4		Washer (Spring) 1/4" Dia.	2
5		Nut 1/4" UNF	2
6	4SHL 86	Hose - Valve to Ram Base 3/8" x 98" x 90°/90°	1
7	S9697	'O' Ring - Seal	6
8	4-60-115	3/8" BSP x 3/4" UNF Parallel Adaptor - Long	2
9	4-35-40K	3/8" BSP x 3/4" UNF Parallel Adaptor - Short	4
10	T-63-M	Clip	2
11	T48	Tube	1
12		Capscrews 5/16" UNF x 1.1/4" Long	4
13	GP-2-A2	Adaptor	2
14	DH-25-19	'O' Ring - Seal	2
15		Spring Washer 5/16" Dia.	4
16		Hex. Head Bolt 5/16" UNF x 3/4" Long	4
17	P2578-2	Cap	1
18	P1145	Strainer	1
19	4/35-187	Cover Plate Assembly	1
20	T-18-B	Gasket	1
21		Hex. Head Bolt 3/8" UNF x 1" Long	4
22		Spring Washer 3/8" Dia.	4
23		Nut 3/8" UNF	4
24	UC-1457	Filter	1
25	2ST118	Hydraulic Tank	1
26	4SHL 94	Hose L.H. Tee - R.H. Ram Base 3/8" x 39" x ST/90°	1
27	T-14-I	3/8" Sealing Washer	1
28	T-14-J	3/8" x 3/8" Parallel Adaptor	1
29	T-14-H	1/2" Sealing Washer	1
30	T-63-K	3/8" x 1/2" BSP Adaptor	1
31	4SHL 82	Hose - Valve to Tank 3/8" x 43" x ST/90°	1
32		3/4" Bore - Cotton Braid Hose - 48" Long	1
33	4SHL 85	Hose - Pump to Valve 3/8" x 29.1/2" x 90°/135°	1
34	3SH 63	Hose - Valve to L.H. Tee 3/8" x 23.1/2" x ST/90°	1
35	4SHL 95	Hose - Valve to R.H. Tee 3/8" x 13" x 90°/90°	1
36	4SHL 97	Tee Bracket	2
37	4SHL 96	Hose - L.H. Tee to L.H. Ram Base 3/8" x 17" x 90°/90°	1
38	4/60/133	Hose R.H. Tee to L.H. Ram Head 3/8" x 48" x ST/90°	1
39	4SHL 93	Hose R.H. Tee to R.H. Ram Head 3/8" x 21.1/2" x ST/ST	1

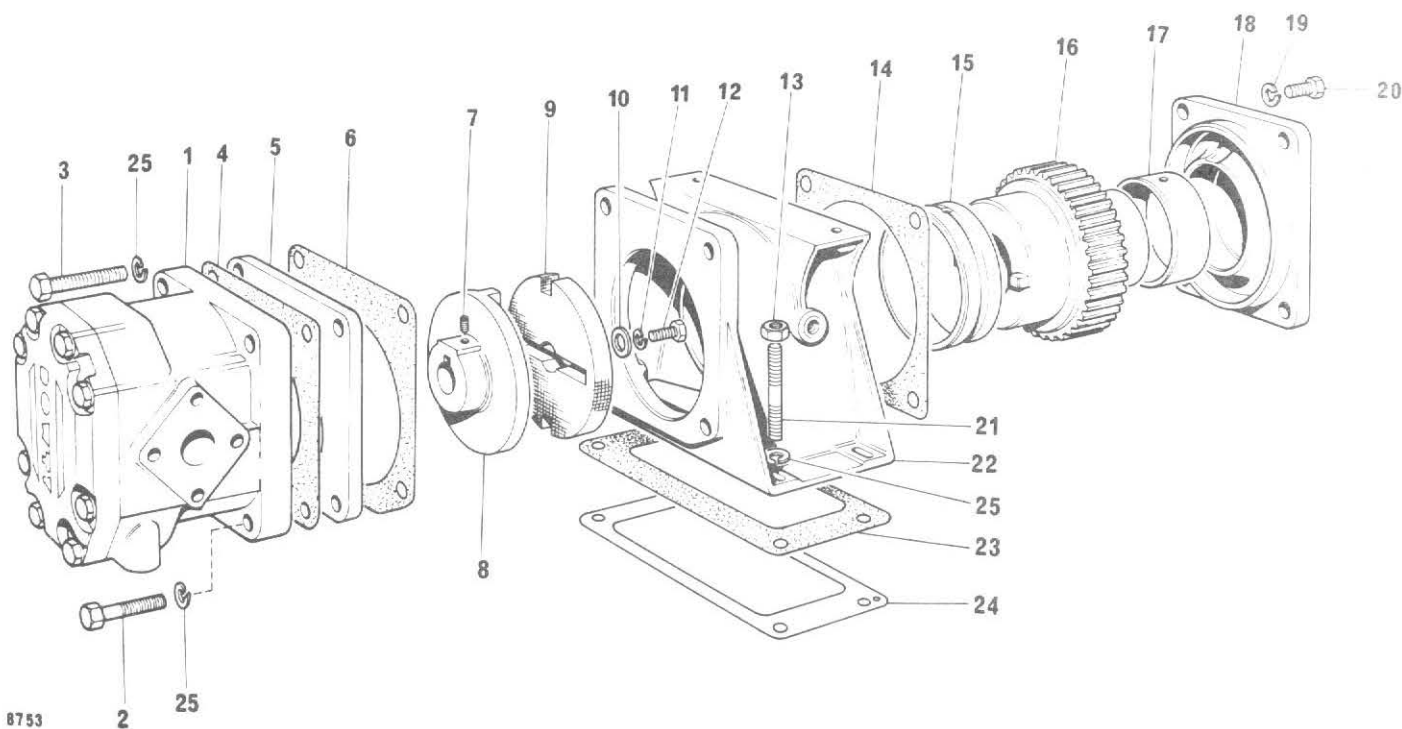

HYDRAULIC PUMP AND DRIVE GEAR

Item No.	Part No.	Description	No. Off.
1	GP265CU	Pump	1
2	NSD110 x 3/8" x 2"	Bolt 3/8" UNF x 2" Long	2
3	NSD110 x 3/8" x 2.1/2"	Bolt 3/8" UNF x 2.1/2" Long	2
4	263871	Joint	1
5	266158	Plate, Spigot	1
6	266159	Joint	1
7	NSD840	Screw, Socket 1/4" x 3/4" Long	1
8	266156	Coupling, Pump	1
9	265413	Block, Coupling	1
10	264705	Washer, Plain	1
11	NSD137 x 1/4"	Washer, Spring x 1/4"	1
12	NSD1004	Set Screw, Pump Shaft 1/4" UNF x 1/2" Long	1
13	NSD20 x 3/8"	Nut 3/8"	4
14	264702	Joint	1
15	2-264704	Bearing Housing	1
16	2-264703	Gearwheel	1
17	2-202485	Bush, Housing	1
18	264701	Cover, Pump Housing	1
19	NSD137 x 5/16"	Washer, Spring x 5/16"	4
20	NSD111	Setscrew, 5/16" x 5/8" Long	4
21	NSD60	Stud 3/8" x 1.1/2"	4
22	2-197597	Housing, Pump	1
23	264700	Joint	1
24	264706	Shim	A/R
25	NSD137	Washer, Spring x 3/8"	8

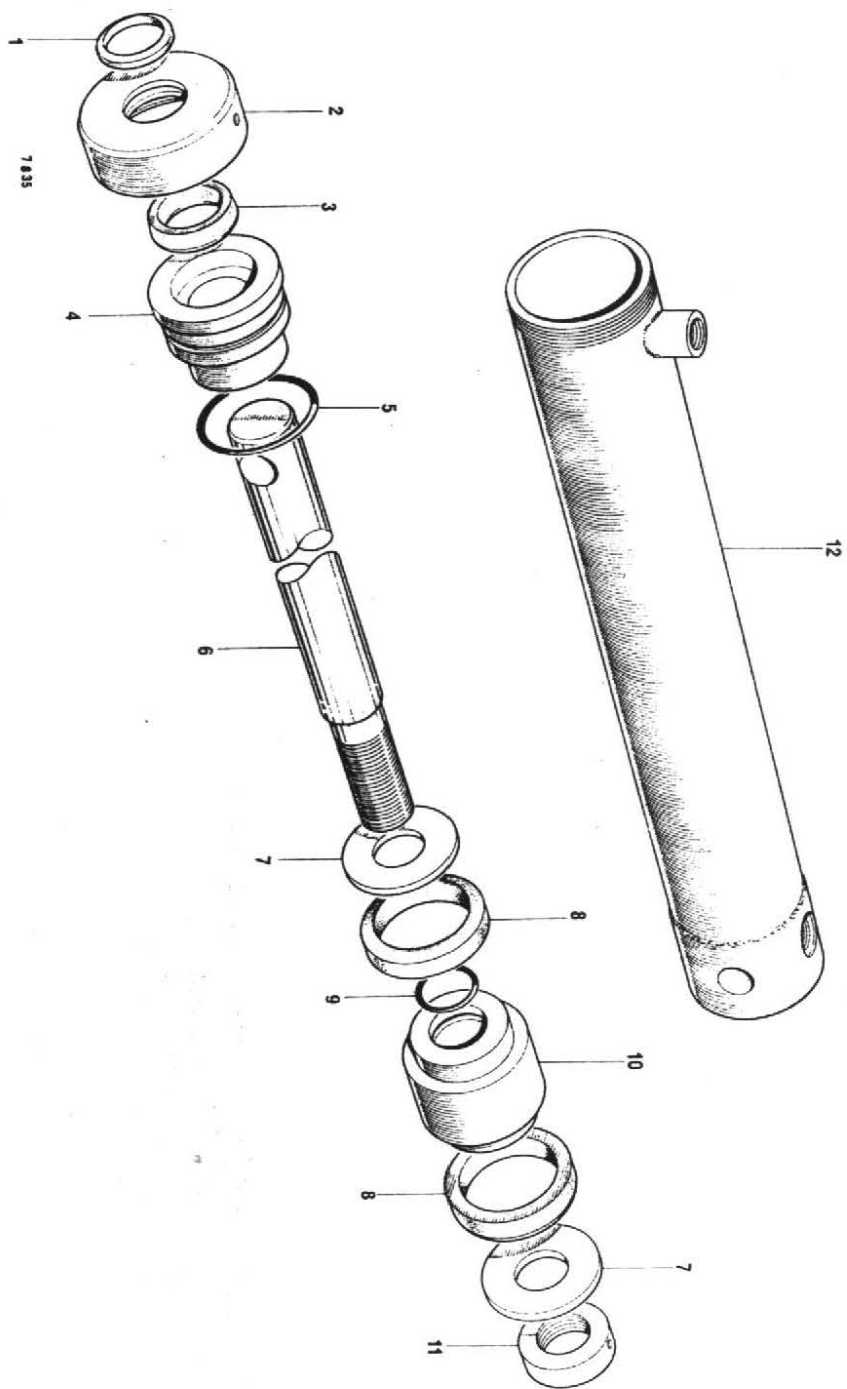

HYDRAULIC CYLINDER – SKIP TIPPING

<i>Item No.</i>	<i>Part No.</i>	<i>Description</i>	<i>No. Off</i>
	3600/75	Hydraulic Cylinder Complete	1
1	3622/75	Wiper	1
2	3603/75	Tube Cap	1
3	3619/75	Sleeve Seal	1
4	3606/75	Tube Sleeve	1
5	3620/75	Sleeve 'O' Ring	1
6	3605/75	Piston Rod	1
7	3618/75	Backing Washer	2
8	3609/75	Piston Seal	2
9	3623/75	Piston Head 'O' Ring	1
10	3604/75	Piston Head	1
11	3621/75	Locknut	1
12	3602A/75	Cylinder	1

5642A

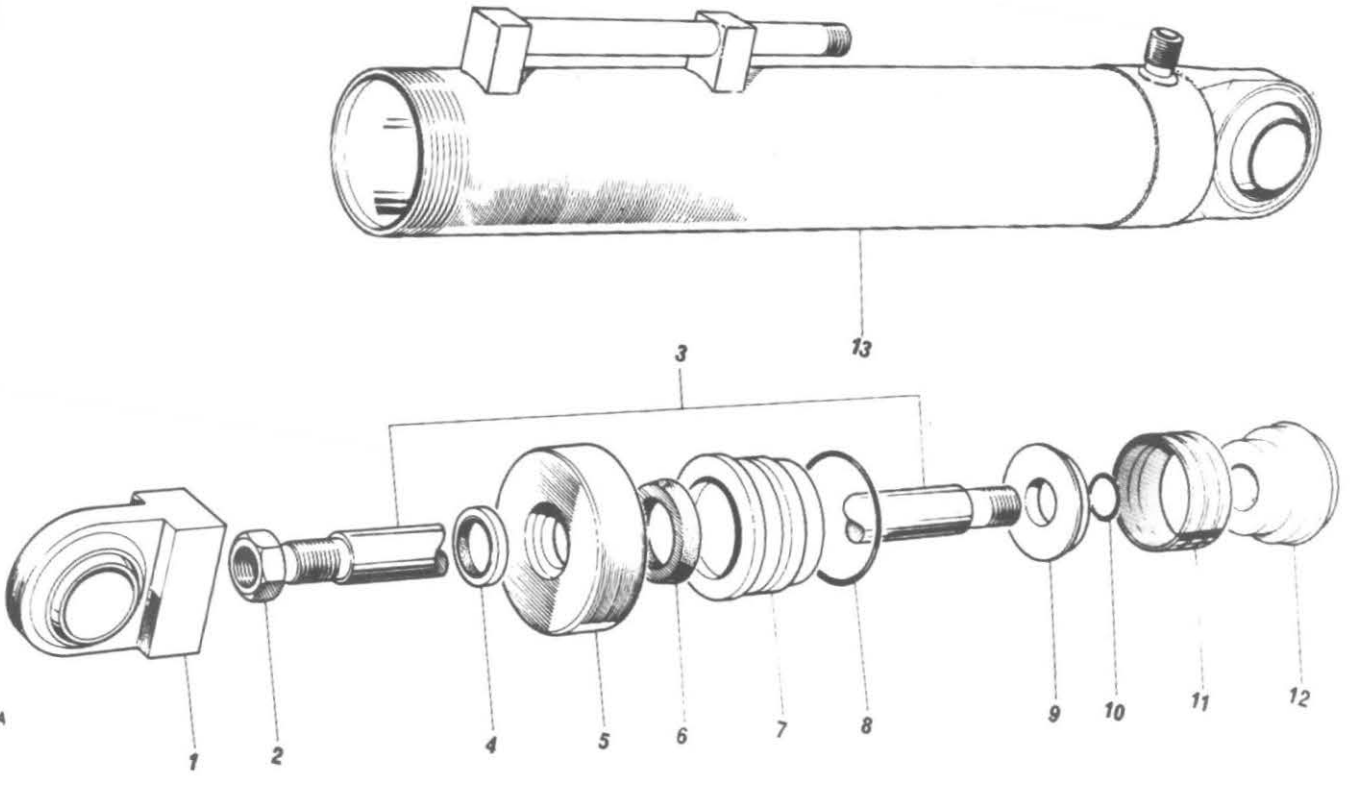

LIFTING CYLINDER

Item No.	Part No.	Description	No. Off
1	TD3894	Cylinder Complete (2 per machine)	1
2	K1/11	Piston Rod Fitting	1
3	K1/19	Locknut	1
4	K1/2	Piston Rod	1
5	K1/18	Wiper	1
6	K1/4	Tube Cap	1
7	K1/17	Sleeve Seal	1
8	K1/5	Sleeve	1
9	K1/16	Sleeve 'O' Ring	1
10	K1/15	Backing Washer	1
11	K1/13	Piston 'O' Ring	1
12	K1/12	Piston Seal	1
13	K1/14	Piston Head	1
	K1/20	Cylinder, Bosses and End Cap	1

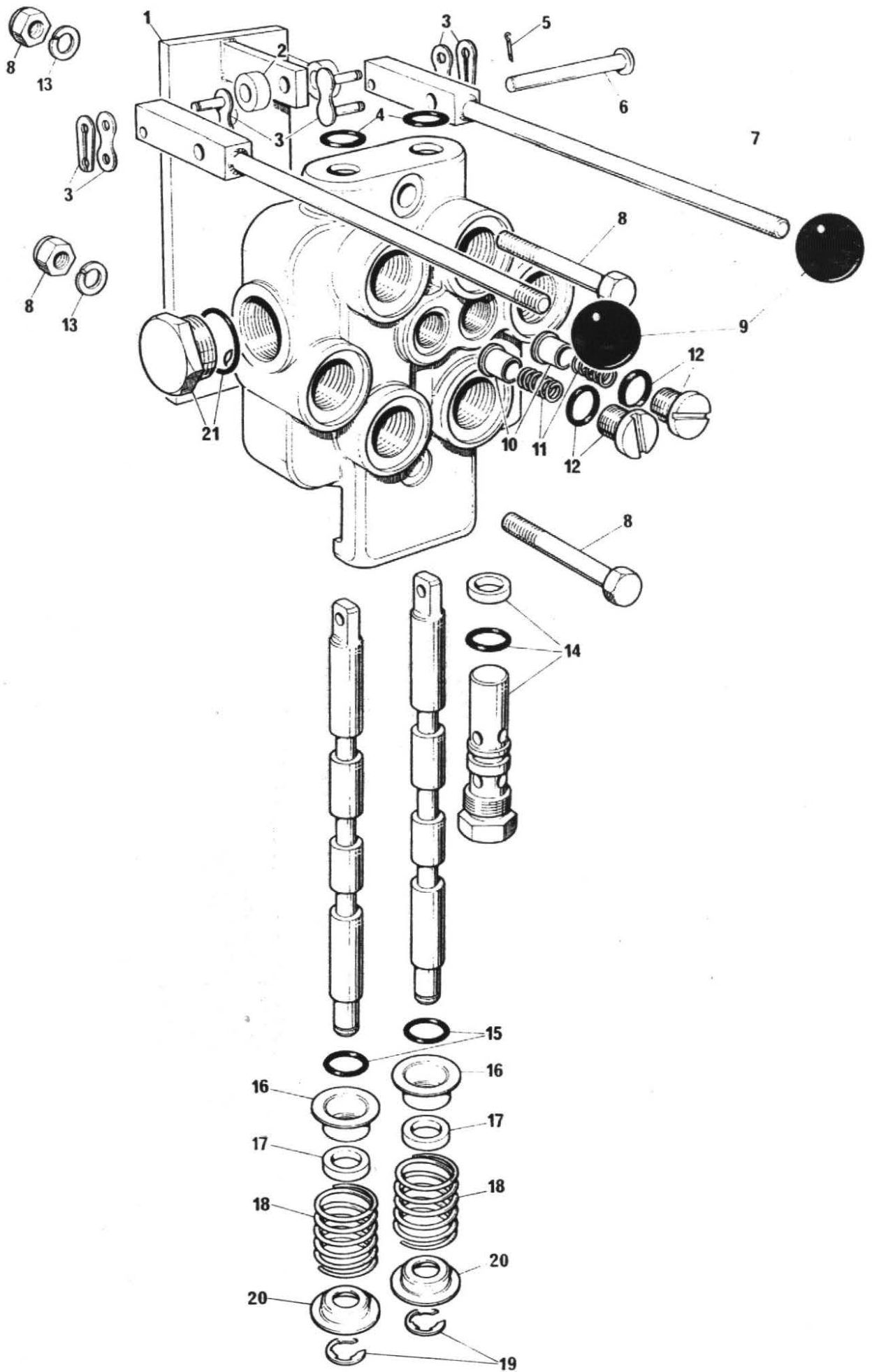

HYDRAULIC VALVE

<i>Item No.</i>	<i>Part No.</i>	<i>Description</i>	<i>No. Off</i>
	300-025-AAH	Hydraulic Control Valve	1
1	4SHL 77	Valve Control Bracket	1
2	2 ST 86	Spacer	2
3	4-60-178	Chain Link	2
4	16004-63	'O' Ring 1/8" x 5/8" I.D.	1
5		Split Pin 1/16" Dia. x 5/8" Long	1
6	4SHL 88	Pin	1
7	4SHL 89	Valve Control Lever	2
8		Nut & Bolt 5/16" x 3" Long	2
9	2 ST 88	Knob	2
10	30501-12	Plunger, Lift Check	2
11	30501-13	Spring, Lift Check	2
12	30501-17	Plug Assy. Lift Check	2
13		3/8" Spring Washer	2
14	32018-L9	Relief Valve Assy.	1
15	16003-12	'O' Ring 3/32" x 5/8" I.D.	2
16	30501-10	Washer, Deep	2
17	16048-31	Washer 59/64" O.D.	2
18	30501-39	Spring Spool Cr.	2
19	16124-50	Clip Ring 1/2" Shaft	2
20	15546-6	Washer, Shallow	2
21	16069-1140	Plug Assy. 7/8" UNF	1

DECIMAL, FRACTIONAL AND METRIC EQUIVALENTS

Inches		Milli- metres	Inches		Milli- metres
Fractions	Decimals		Fractions	Decimals	
1/64	0.015625	0.397	33/64	0.515625	13.097
1/32	0.03125	0.794	17/32	0.53125	13.494
3/64	0.046875	1.191	35/64	0.546875	13.891
1/16	0.0625	1.588	9/16	0.5625	14.288
5/64	0.078125	1.984	37/64	0.578125	14.684
3/32	0.09375	2.381	19/32	0.59375	15.081
7/64	0.109375	2.778	39/64	0.609375	15.478
1/8	0.125	3.175	5/8	0.625	15.875
9/64	0.140625	3.572	41/64	0.640625	16.272
5/32	0.15625	3.969	21/32	0.65625	16.669
11/64	0.171875	4.366	43/64	0.671875	17.066
3/16	0.1875	4.763	11/16	0.6875	17.463
13/64	0.203125	5.159	45/64	0.703125	17.859
7/32	0.21875	5.556	23/32	0.71875	18.256
15/64	0.234375	5.953	47/64	0.734375	18.653
1/4	0.250	6.350	3/4	0.750	19.050
17/64	0.265625	6.747	49/64	0.765625	19.447
9/32	0.28125	7.144	25/32	0.78125	19.844
19/64	0.296875	7.541	51/64	0.796875	20.241
5/16	0.3125	7.938	13/16	0.8125	20.638
21/64	0.328125	8.334	53/64	0.828125	21.034
11/32	0.34375	8.731	27/32	0.84375	21.431
23/64	0.359375	9.128	55/64	0.859375	21.828
3/8	0.375	9.525	7/8	0.875	22.225
25/64	0.390625	9.922	57/64	0.890625	22.622
13/32	0.40625	10.319	29/32	0.90625	23.019
27/64	0.421875	10.716	59/64	0.921875	23.416
7/16	0.4375	11.113	15/16	0.9375	23.813
29/64	0.453125	11.509	61/64	0.953125	24.209
15/32	0.46875	11.906	31/32	0.96875	24.606
31/64	0.484375	12.303	63/64	0.984375	25.003
1/2	0.500	12.700	1	1.000	25.400

INCHES INTO MILLIMETRES

Inches	0	1	2	3	4	5	6	7	8	9
0	0	25.40	50.80	76.20	101.60	127.00	152.40	177.80	203.20	228.60
10	254.00	279.40	304.80	330.20	355.60	381.00	406.40	431.80	457.20	482.60
20	508.00	533.40	558.80	584.20	609.60	635.00	660.40	685.80	711.20	736.60
30	762.00	787.40	812.80	838.20	863.60	889.00	914.40	939.80	965.20	990.60
40	1016.00	1041.40	1066.80	1092.20	1117.60	1143.00	1168.40	1193.80	1219.20	1244.60
50	1270.00	1295.40	1320.80	1346.20	1371.60	1397.00	1422.40	1447.80	1473.20	1498.60
60	1524.00	1549.40	1574.80	1600.20	1625.60	1651.00	1676.40	1701.80	1727.20	1752.60
70	1778.00	1803.40	1828.80	1854.20	1879.60	1905.00	1930.40	1955.80	1981.20	2006.60
80	2032.00	2057.40	2082.80	2108.20	2133.60	2159.00	2184.40	2209.80	2235.20	2260.60
90	2286.00	2311.40	2336.80	2362.20	2387.60	2413.00	2438.40	2463.80	2489.20	2514.60

Use in conjunction with above table.

Example: Find equivalent mm. for 84 5/8".

$$84'' = 2133.60 \text{ mm.}$$

$$5/8'' = 15.875 \text{ mm.}$$

$$84 \text{ } 5/8'' = 2149.475 \text{ mm.}$$

CALIFORNIA

Proposition 65 Warning

Diesel engine exhaust and some of its constituents are known to the State of California to cause cancer, birth defects, and other reproductive harm