

WINGET

OPERATING INSTRUCTIONS & SPARE PARTS LIST

4B40 DIESEL DUMPER (CAPACITY 2000KG)

**ISSUED NOVEMBER 1980
REVISED JUNE 1981 &
FEBRUARY 1982
REPRINTED OCTOBER 2002**

**WINGET LIMITED
PO BOX 41
EDGEFOLD INDUSTRIAL ESTATE
PLODDER LANE
BOLTON
LANCS
BL4 OLS**

**TEL: ++ 44 (0) 1204 854650
FAX: ++ 44 (0) 1204 854663
service@winget.co.uk
parts@winget.co.uk
www.winget.co.uk**

INTRODUCTION

This Parts & Operators Manual is a re-print of the manual last published in 1982 and contains some amended part numbers.

Note: this publication is applicable to machines with serial numbers from and including 4B40-101.

Health & Safety legislation and working practices applicable to Site Dumpers, both 2 and 4 wheel Drive, Rigid Chassis and Articulated Chassis have changed considerably in the years since this manual was last published and immediately following this Introduction are notes on the Safe Use of Site Dumpers. These notes supersede and replace all previous 'Dumper Safety' notes issued with Winget 4B40 Four Wheel Drive Dumpers.

Reference is made on a number of pages to 'bolt c/w nut and washer', this no longer the case, fixings such as nuts, bolts, screws and washers should be ordered as individual items. A number of Whitworth and B.S.F fixings are now no longer available, in these cases the nearest metric equivalent size will be supplied.

The contents of this manual although correct at the time of publication, may be subject to alteration by the manufacturers without notice and Winget Limited can accept no responsibility for any errors or omissions contained within the following pages. Nor can we accept any liability whatsoever arising from the use of this manual howsoever caused.

Winget Limited operate a policy of continuous product development. Therefore, some illustrations or text within this publication may differ from your machine.

WINGET LIMITED
PO BOX 41
EDGEFOLD INDUSTRIAL ESTATE
PLODDER LANE
BOLTON
LANCS
BL4 OLS
TEL ++ 44 (0) 1204 854650
FAX ++ 44 (0) 1204 854663
E mail service@winget.co.uk
parts@winget.co.uk
www.winget.co.uk

DUMPER SAFETY

Safety is the responsibility of all persons working with this machine. Think "safety" at all times. Read and remember the contents of this handbook.

MACHINE MODIFICATIONS

WARNING Any modifications to the machine will affect its working parameters and safety factors. Refer to the Manufacturers before fitting any non-standard equipment or parts.



The Manufacturers accept no responsibility for any modifications made after the machine has left the factory, unless previously agreed by the Manufacturers in writing; the Manufacturers will accept no liability for damage to property, personnel or the machine if failure is brought about due to such modifications, or fitment of spurious parts.

TRAINING

WARNING Only trained operators should use this machine.



Operators should hold an appropriate full motor vehicle driving licence and undergo both a safety awareness course and a driver training course for Site dumpers run by the C.ITB or equivalent body leading to the award of a CTA.

It is strongly recommended that operators read the H.S.E. publication "Safe Working with Small Dumpers" which is available from government bookshops (HMSO) or from other bookshops quoting the following number ISBN 011 8836935. Another useful publication is British Standard number BS 6264, "Procedure for Operator Training For Earth Moving Machinery" available from the British Standard Institution.

OPERATION

WARNING *NEVER* use the machine for purposes other than those for which it was designed. This machine was designed to carry loads such as soil, clay, sand, wet concrete, stone or other similar materials. It was not designed to carry loads which may move around in the skip uncontrollably, nor to carry any loads or materials which overhang the skip in any way. If in any doubt as to the suitability of this machine for a particular task, contact your nearest Distributor or the Manufacturer for advice.



ALWAYS be aware of local and national regulations governing the use of the machine.

NEVER commence work with the machine until the "Daily (or every ten hours)" service checks have been made. (See *Service Section* for details)

ALWAYS check wheel nut tightness daily.

NEVER carry passengers.

Where seat belt restraints are fitted as part of Rops/Fops Protection they must be worn. Ensure that the seat and seat belt are securely fixed to the machine. Check that the seat belt is in good condition, free from cuts and frayed edges.

ALWAYS remain in the driving seat whenever the engine is running. Never attempt to operate any controls unless seated.

ALWAYS apply the parking brake before leaving the driver's seat.



DUMPER SAFETY

NEVER dismount with the engine running, and never leave the machine unattended with the key in the starter switch.

When Battery Isolators are fitted they must be activated only when the engine is turned off except in cases of emergency.

Activating a Battery Isolator when the engine is running can result in damage to the electrical components and circuits.

NEVER fill the fuel or hydraulic tanks with the engine running.

ALWAYS drive only on surfaces that are known to be stable.

ALWAYS keep the floor plates and walkways clean.

NEVER drive the machine close to the edge of any excavation. Always use effective wheel stops to prevent the machine running close to the edge. Make sure that the stops are in proportion to the size of the wheels and are set sufficiently far enough back from the edge of any excavation to prevent the weight of the load causing a collapse.

NEVER adjust the tyre pressures in an attempt to improve traction on soft ground or obtain a softer ride on hard ground. Incorrectly adjusted tyres can affect the steering and handling characteristics.

NEVER attempt to free a machine which is 'bogged down' by pushing with the bucket of a backhoe loader, tracked excavator or other similar machine.

NEVER make unnecessary "crash stops" when travelling at speed, especially in forward direction.

NEVER work under an unpropped skip. *If the dumper was supplied with a special Skip Support always ensure that it is used.*

Some articulating dumpers are manufactured with an articulation lock. If your machine has this feature proceed as follows:

ALWAYS fit the articulation lock when working within the articulation point crush zone.

NEVER attempt to lift the machine unless the articulation lock is engaged.

SKIPS AND LOADING

WARNING *NEVER* exceed the rated payload. The weights of all loads above skip water level must be checked.



NEVER remain on the machine when loading the skip with excavators or loaders. Stop the engine, apply the parking brake, dismount, and stand well clear.

ALWAYS ensure that the load is evenly distributed in the skip.

NEVER carry loads or heap materials in such a manner as to affect the forward vision.

ALWAYS take extra care when tipping non free running loads.

NEVER use the skip in a tipped position to bulldoze heaped materials level or to backfill material into excavations.

DUMPER SAFETY

TOWING

WARNING NEVER attempt to start the engine of a dumper by towing or pushing.



Dumpers are not designed as towing vehicles, but loads (including weight of trailer) not exceeding the rated payload of the dumper may be towed on dry level ground in first gear, providing the dumper skip is loaded with half the rated payload to ensure tyre adhesion when braking.

ALWAYS use a purpose made towing pin.

NEVER tow loads up, down or across gradients.

GRADIENTS

WARNING NEVER operate *Four Wheel Drive articulated steer dumpers* on any gradients which exceed 25% (1 in 4), or across gradients which exceed 16% (1 in 6).



NEVER operate *Two Wheel Drive rigid chassis dumpers* on any gradients which exceed 10% (1 in 10), or across gradients which exceed 10% (1 in 10).

ALWAYS remember that slippery or loose surface conditions can adversely affect safe machine operation, including braking, particularly on gradients.

ALWAYS choose routes that avoid steep, slippery or loose gradients.

NEVER coast down gradients. Always negotiate gradients in first gear.

ALWAYS drive forwards up gradients when loaded.

ALWAYS reverse down gradients when loaded.

ALWAYS keep the load facing uphill.

NEVER park on a gradient. If this is unavoidable, ALWAYS chock the wheels.

NEVER attempt to turn on a gradient.

NEVER tow up, down or across a gradient.

NEVER operate high discharge or rotating skips on gradients.

HYDRAULICS

WARNING ALWAYS "Dump" residual pressure from the system before leaving the machine or before carrying out any maintenance or adjustments.



If maintenance work requires the skip to be in the raised position, then it must be raised and supported before dumping the pressure.

Dump pressure by switching off the engine, then moving the hydraulic control lever several times in each direction.

NEVER leave the machine unattended with pressure in the system.

ALWAYS purge hydraulic rams before commencing work. With the engine running operate the hydraulic control to fully extend and retract the rams.

ALWAYS practise the greatest cleanliness in maintaining hydraulic components.

DUMPER SAFETY

SERVICING

WARNING ALWAYS report any defect at once, before an accident or consequential damage can occur.



ALWAYS conform to service schedules except where:

- 1 Warning lights or warning indicators call for immediate attention.
- 2 Adverse conditions necessitate more frequent servicing.

ALWAYS wear correctly fitting protective clothing. Loose or baggy clothing can be extremely dangerous when working on running engines or machinery.

ALWAYS, where possible, work on or close to engines or machinery only when they are stopped. If this is not practical, remember to keep tools, test equipment and all parts of your body well away from the moving parts.

ALWAYS dump pressure from the hydraulic system before carrying out any kind of maintenance or adjustment. (*see Hydraulics Warnings*).

ALWAYS avoid contact with exhaust pipes, exhaust manifolds and silencers when the engine is running; these can be very hot.

ALWAYS work out of doors, or in a well-ventilated area.

NEVER run an engine in an enclosed space. Exhaust fumes in enclosed areas can kill.

ALWAYS disconnect battery cables and remove battery before using an external charger, carrying out welding repairs or to prevent unauthorised usage when unattended or during a repair.

NEVER allow unqualified personnel to attempt to repair, remove or replace any part of the machine, or anyone to remove large or heavy components without adequate lifting tackle.

NEVER attempt to modify or repair Rops Frames or Fops Canopies by welding, drilling or any other means. Attempts to do so will invalidate Rops/Fops Certification.

ALWAYS obtain advice before mixing oils; some are incompatible. If in doubt drain and refill.

NEVER allow oils and fuels to come into regular contact with skin. This can lead to serious skin diseases including, medical evidence suggests, skin cancer. ALWAYS wear protective gloves when handling oils and fuels whether topping up, draining or refilling. ALWAYS wash hands if oils or fuels come into contact with the skin.

Many liquids used in this machine are harmful if taken internally or splashed into the eyes. In the event of accidentally swallowing oils, fuels, anti-freeze, battery acid etc, DO NOT encourage vomiting, seek qualified medical assistance immediately.

ALWAYS dispose of waste oils and fuels into waste oil storage tanks. If storage tanks are not available consult your distributor or local authority for addresses of local designated disposal points. It is illegal to dispose of waste oil into drains or water courses or to bury it.

DUMPER SAFETY

Equipment which includes friction materials will sometimes contain asbestos. When removing friction material dust from components, such as when servicing brakes or clutches, do not blow out with an airline; it could be harmful to inhale the dust. Remove the dust with a vacuum cleaner or wipe clean with a damp rag. Waste should be placed in a sealed container, marked, and disposed of in accordance with local or national regulations.

The accumulated dust found in clutch housings may contain lead/antimony. No food should be eaten at a work place contaminated by this dust. Hands must be washed before eating. Do not blow out dust with an airline.

ALWAYS ensure that the starting handle is clean and in good condition. Keep the engine starting dog, and the part of the starting handle that mates with it, lightly lubricated (*Refer to the Engine Handbook*).

NEVER work under an unpropped skip. ***If the dumper was supplied with a special Skip Support always ensure that it is used.***

Some articulating dumpers are manufactured with an articulation lock. If your machine has this feature, ALWAYS fit the articulation lock when servicing or working on the machine.

PREPARATION FOR USE

Before the Dumper is put into service, always check the following points:-

ENGINE

Check the oil level on the dipstick, topping up if necessary to the full mark.

GEARBOX

Check the oil level on the dipstick, topping up if necessary to the full mark.

DRIVE AXLES AND TRANSFER CASE

Remove filler/level plugs from drive axles and filler/level plug from transfer case and check that oil is up to bottom of holes. Top up if necessary, through filler/level plugs.

FUEL TANK

Fill tank with diesel oil until approximately 1" from the top.

NOTE: Never allow fuel level to fall below 2" deep in the bottom of the tank.

HYDRAULIC TANK

Fill the hydraulic tank to within 2" of the top. Before removing the cap, clean the surrounding area to prevent the possible entry of foreign matter.

BRAKE SYSTEM

Ensure that the fittings are tight on hoses supplying the brake master cylinder from the main hydraulic tank.

MISCELLANEOUS

Check all wheel nuts for tightness.

Check all nuts and bolts for tightness, loose nuts and bolts may lead to damage not covered by Warranty.

N.B. FOR FURTHER INFORMATION ABOUT LUBRICATION AND RECOMMENDED OILS SEE RECOMMENDED LUBRICANT CHART & GENERAL MAINTENANCE SECTION.

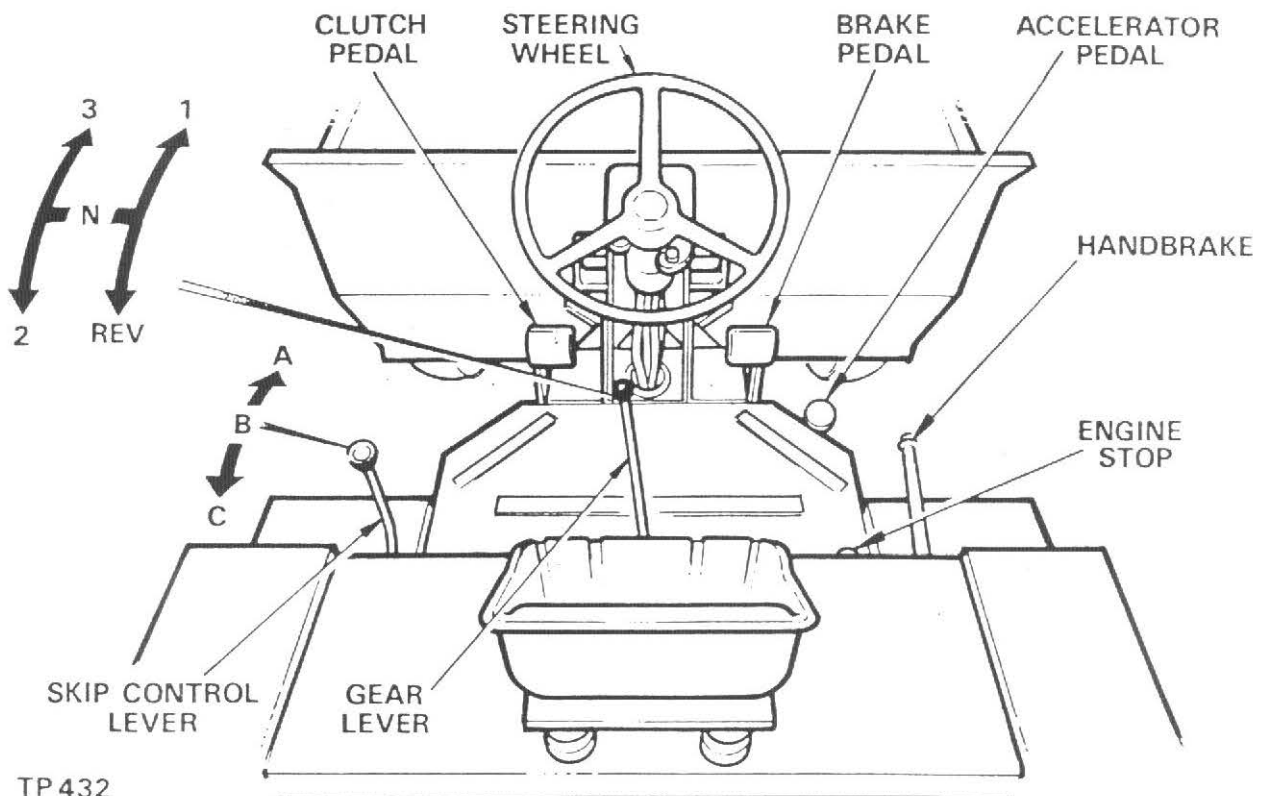

TP432

SPECIFICATION FOR MACHINES WITH FORWARD TIP SKIP

A	Overall Height	1820 mm	(5' 11½")
B	Skip Loading Height	1210 mm	(3' 11½")
C	Wheelbase	1790 mm	(5' 10½")
D	Overall Length	3560 mm	(11' 8")
E	Ground Clearance	200 mm	(8")
F	Overall Width	1755 mm	(5' 9")
G	Skip Ground Clearance when Tipped	485 mm	(1' 7")
H	Overall Height Tipped	2280 mm	(7' 5¾")
J	Discharge Forward of Tyre	600 mm	(1' 11½")
K	Overhang	920 mm	(3' 0")
L	Wheeltrack	1390 mm	(4' 6")
M	Prow Width	1625 mm	(5' 4")

Skip		Turning Circle	7450 mm	(24' 5")
Water Level	0.85m ³	(30 cu.ft.)	Unladen Weight	1820 Kgs. (4013 lbs.)
Struck Level	1.10m ³	(39 cu.ft.)	Hyd. Relief Valve	123 Kg/cm ² (1750 psi.)
Heaped Level	1.50m ³	(52 cu.ft.)	Rear Axle Artic.	305 mm (12")
Maximum Payload	2032 Kgs.	(4480 lbs.)	Tank Capacities	
Oil Capacities			Hydraulic	29.5 Ltrs. (6½ galls.)
Transfer Box	.85 Ltrs.	(1½ pts.)	Diesel	29.5 Ltrs. (6½ galls.)
Gearbox	.85 Ltrs.	(1½ pts.)	Tyre Pressure	35 p.s.i.
Drive Axle	4.6 Ltrs.	(8 pts.)		
Engine Lister	7.5 Ltrs.	(13.2 pts.)		
Engine Petter	6.8 Ltrs.	(12 pts.)		

Road Speeds

	Petter		Lister	
	m.p.h.	k.p.h.	m.p.h.	k.p.h.
1st	2.2	(3.6)	2.7	(4.3)
2nd	5.2	(8.4)	6.2	(10.0)
3rd	10.0	(16.1)	11.5	(18.5)
Rev	2.5	(4.0)	3.0	(4.8)

Engine Specification

Petter PH2 S & E Schedule 1079	(Hand Start)
Petter PH2 S & E Schedule 1083	(Elect.Start)
Lister ST2 S & E Schedule 1081	(Hand Start)
Lister ST2 S & E Schedule 1082	(Elect.Start)

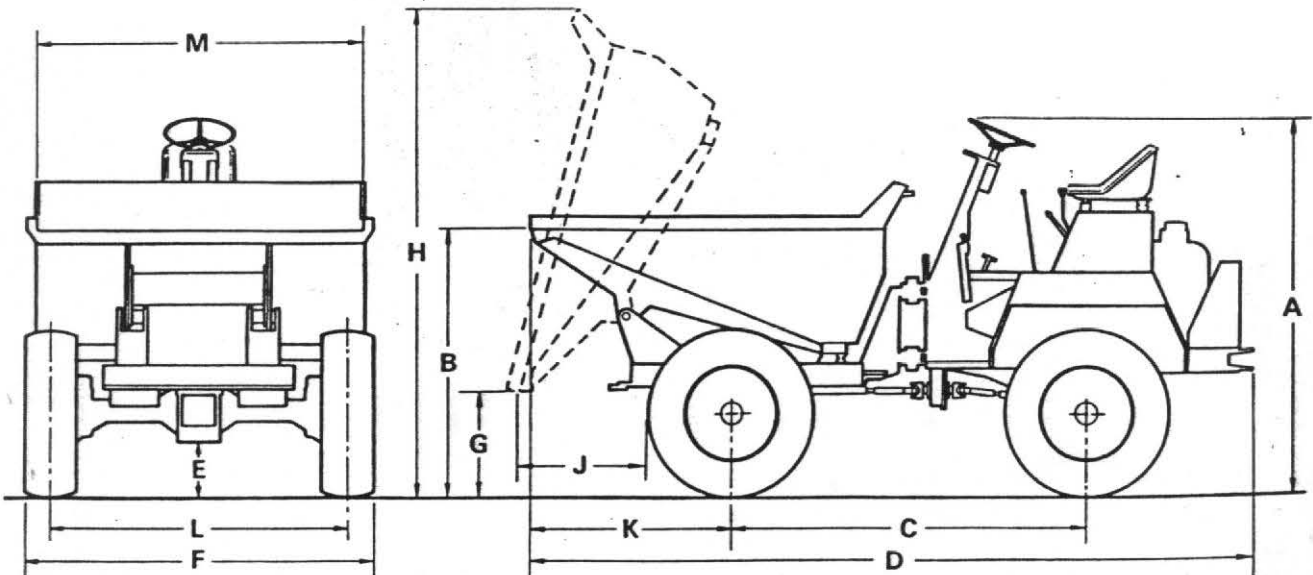

TP 435

SPECIFICATION FOR MACHINES WITH HIGH DISCHARGE SKIP

A Overall Height	1970 mm	(6' 5½")
B Skip Loading Height	1810 mm	(5' 11½")
C Wheelbase	1790 mm	(5' 10½")
D Overall Length	3447 mm	(11' 3¾")
E Ground Clearance	200 mm	(8 ")
F Overall Width	1745 mm	(5' 8 ")
G Skip Ground Clearance	1685 mm	(5' 5½")
H Overall Height Tipped		
J Discharge Forward of Tyre	522 mm	(1' 8½")
K Overhang	822 mm	(2' 8 ")
L Wheeltrack	1390 mm	(4' 6 ")
M Prow Width	667 mm	(2' 2 ")

Skip		Turning Circle	7450 mm	(24' 5")
Water Level	0.960m ³	(30 cu.ft.)	Unladen Weight	1872 Kgs. (4127 lbs.)
Maximum Payload	2032 Kgs.	(4480 lbs.)	Hyd.Relief Valve	123 Kg/cm ² (1750 psi.)
Oil Capacities			Rear Axle Artic.	305 mm (12")
Transfer Box	.85 Ltrs.	(1½ pts.)	Tank Capacities	
Gearbox	.85 Ltrs.	(1½ pts.)	Hydraulic	29.5 Ltrs. (6½ galls.)
Drive Axle	4.6 Ltrs.	(8 pts.)	Diesel	29.5 Ltrs. (6½ galls.)
Engine Lister	7.5 Ltrs.	(13.2 pts.)	Tyre Pressure	35 p.s.i.
Engine Petter	6.8 Ltrs.	(12 pts.)		

Road Speeds

Petter

Lister

Engine Specification

	m.p.h.	k.p.h.	m.p.h.	k.p.h.	
1st	2.24	(3.6)	2.7	(4.3)	Petter PH2 S & E Schedule 1079 (Hand Start)
2nd	5.2	(8.4)	6.2	(10.0)	Petter PH2 S & E Schedule 1083 (Elect.Start)
3rd	10.0	(16.1)	11.5	(18.5)	Lister ST2 S & E Schedule 1081 (Hand Start)
Rev	2.5	(4.0)	3.0	(4.8)	Lister ST2 S & E Schedule 1082 (Elect.Start)

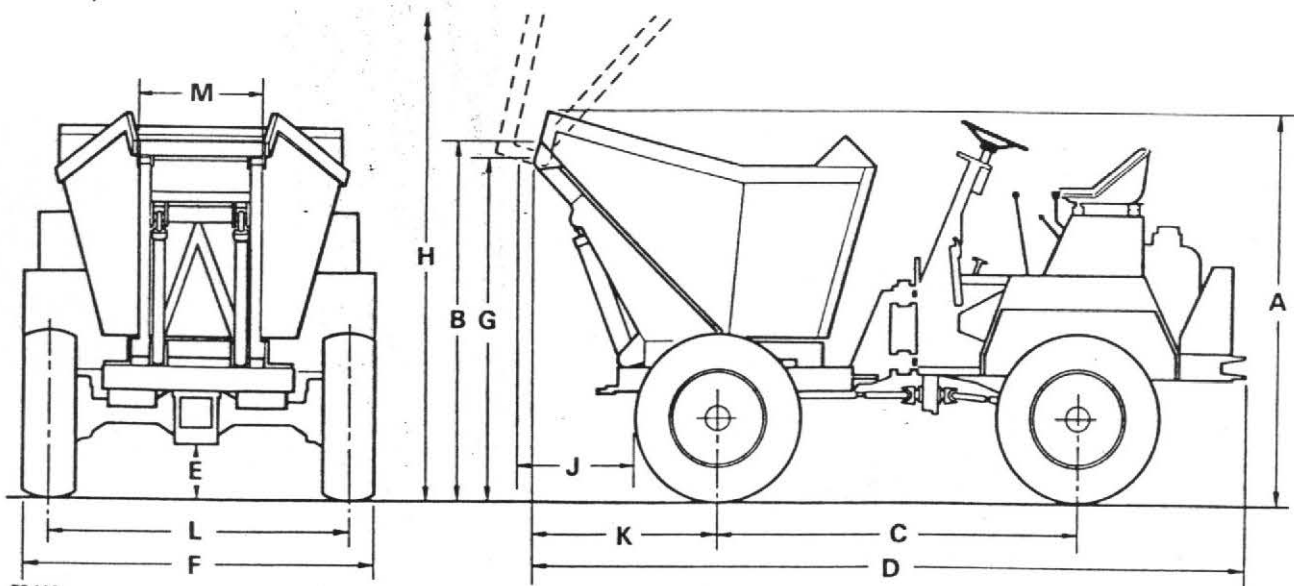

TP 433

SPECIFICATION FOR MACHINES WITH ROTATING TIP SKIP

A	Overall Height	1910 mm	(6' 3")
B	Skip Loading Height	1440 mm	(4' 8½")
C	Wheelbase	1790 mm	(5' 10½")
D	Overall Length	3625 mm	(11' 10½")
E	Ground Clearance	200 mm	(8")
F	Overall Width	1745 mm	(5' 8½")
G	Skip Ground Clearance when Tipped	630 mm	(2' 1")
H	Overall Height Tipped		
J	Discharge Forward of Tyre		
K	Overhang	1045 mm	(3' 5")
L	Wheeltrack	1390 mm	(4' 6½")
M	Prow Width	792 mm	(2' 7")

Skip			Turning Circle	7450 mm	(24' 5")
Water Level	0.680m ³	(24 cu.ft.)	Unladen Weight	1857 Kgs.	(4094 lbs.)
Struck Level	0.875m ³	(34 cu.ft.)	Hyd. Relief Valve	123 Kg/cm ²	(1750 psi.)
Heaped Level	1.130m ³	(40 cu.ft.)	Rear Axle Artic.	305 mm	(12")
Maximum Payload	1525 Kgs.	(3362 lbs.)	Tank Capacities		
Oil Capacities			Hydraulic	29.5 Ltrs.	(6½ galls.)
Transfer Box	.85 Ltrs.	(1½ pts.)	Diesel	29.5 Ltrs.	(6½ galls.)
Gearbox	.85 Ltrs.	(1½ pts.)	Tyre Pressure	35 p.s.i.	
Drive Axle	4.6 Ltrs.	(8 pts.)			
Engine Lister	7.5 Ltrs.	(13.2 pts.)			
Engine Petter	6.8 Ltrs.	(12 pts.)			

Road Speeds

	Petter		Lister	
	m.p.h.	k.p.h.	m.p.h.	k.p.h.
1st	2.24	(3.6)	2.7	(4.3)
2nd	5.2	(8.4)	6.2	(10.0)
3rd	10.0	(16.1)	11.5	(18.5)
Rev	2.5	(4.0)	3.0	(4.8)

Engine Specification

Petter PH2 S & E	Schedule 1079
	(Hand Start)
Petter PH2 S & E	Schedule 1083
	(Elect.Start)
Lister ST2 S & E	Schedule 1081
	(Hand Start)
Lister ST2 S & E	Schedule 1082
	(Elect.Start)

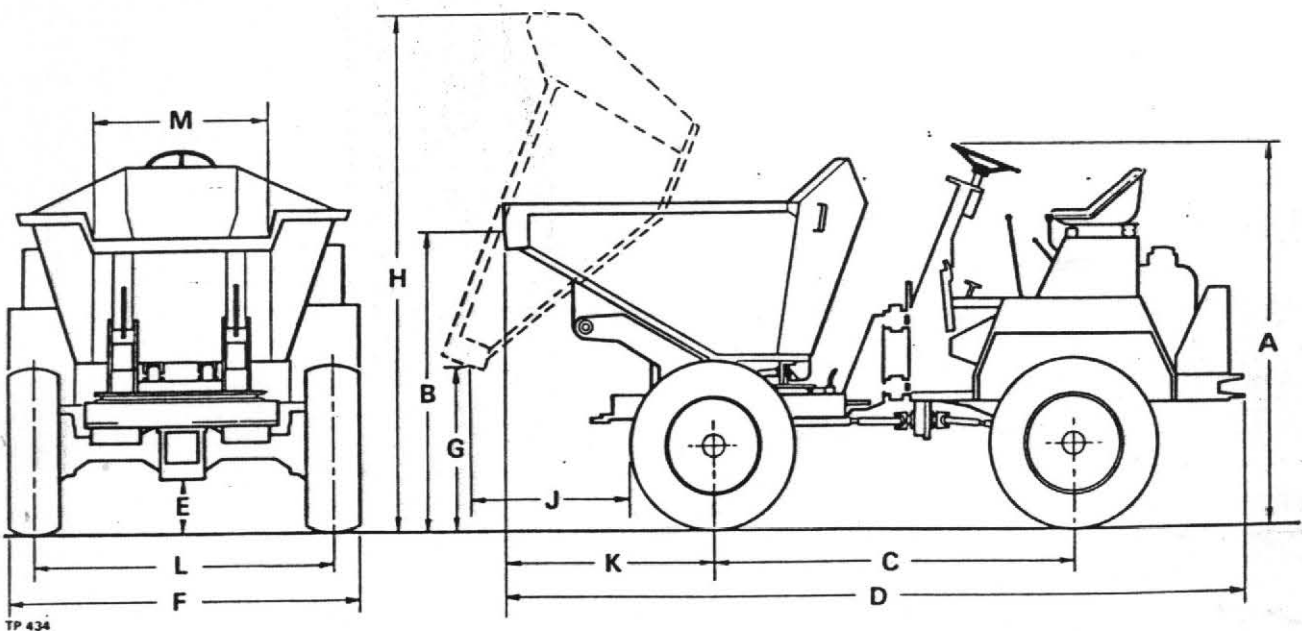

TP 434

RECOMMENDED LUBRICATING OILS

SALISBURY AXLES

COMPANY		ENGINE	DRIVE AXLE TRANSFER BOX & STEERING BOX	GEARBOX	WHEEL BEARINGS & OTHER GREASE POINTS	HYDRAULIC SYSTEM
(U.K.) ESSO	SUMMER	ESSOLUBE HDX 20W	GEAR OIL GP 85W/140	ESSOLUBE HDX 30	BEACON 2	NUTO H32
	WINTER	ESSOLUBE HDX 30	GEAR OIL GP 85W/140	ESSOLUBE HDX 30	BEACON 2	NUTO H68
(Overseas)	ABOVE 32°C	ESSOLUBE HDX 20W	GEAR OIL GP 85W/140	ESSOLUBE HDX 30	BEACON 2	NUTO H32
	0-32°C	ESSOLUBE HDX 10W	GEAR OIL GP 80W			NUTO H22
	BELOW 0°C					
(U.K.) CASTROL	SUMMER	DEUSOL CRI 20	DEUSOL GEAR EP 90	DEUSOL CRI 30	CASTROL SPHEEROL APT 2	CASTROL HYPIN AWS 32
	WINTER	DEUSOL CRI 30	DEUSOL GEAR EP 140	DEUSOL CRI 30	CASTROL SPHEEROL APT 2	
	ABOVE 32°C	DEUSOL CRI 20	DEUSOL GEAR EP 90			
	0-32°C	DEUSOL CRI 10	DEUSOL GEAR EP 80			
	BELOW 0°C					
(U.K.) SHELL	SUMMER	ROTELLA SX OIL 20/20W	SPIRAX 90 EP	ROTELLA SX OIL 30	RETINAX A	TELLUS OIL 37
	WINTER	ROTELLA SX OIL 30	SPIRAX 140 EP	ROTELLA SX OIL 30	RETINAX A	
	ABOVE 32°C	ROTELLA SX OIL 20/20W	SPIRAX 90 EP			
	0-32°C	ROTELLA SX OIL 10W	SPIRAX 80 EP			
	BELOW 0°C					
(U.K.) BP	SUMMER	VANELLUS M20W	GEAR OIL SAE 90 EP	VANELLUS M30	ENERGREASE L2	ENERGOL HLP 65
	WINTER	VANELLUS M30	GEAR OIL SAE 140 EP	VANELLUS M30	ENERGREASE L2	
	ABOVE 32°C	VANELLUS M20W	GEAR OIL SAE 90 EP			
	0-32°C	VANELLUS M10W	GEAR OIL SAE 80 EP			
	BELOW 0°C					
(U.K.) MOBIL	SUMMER	DELVAC 1220	MOBILUBE HD 90	DELVAC 1230	MOBILGREASE MP	DTE 24
	WINTER	DELVAC 1230	MOBILUBE GX 90	DELVAC 1230		
		ABOVE 32°C	DELVAC 1230	MOBILUBE HD 140	MOBILGREASE SUPER	
		0-32°C	DELVAC 1220	MOBILUBE GX 140		
	BELOW 0°C	DELVAC 1210	MOBILUBE HD 90	DELVAC 1230		
	ALL TEMPERATURES	DELVAC SPECIAL 10W-30	MOBILUBE GX 90			
			MOBILUBE HD 80			
			MOBILUBE GX 80			
(U.K.) WALKERS	SUMMER	CENTURY ROIL 20W 20	CENTURY EP 90	CENTURY ROIL 30	REGULUS A2	CENTURY PWLA HYD OIL
	WINTER	CENTURY ROIL 30	CENTURY EP 140	CENTURY ROIL 30	REGULUS A2	CENTURY PWLA HYD OIL
	ABOVE 32°C	CENTURY ROIL 20W 20	CENTURY EP 90			
	0°C-32°C	CENTURY ROIL 10W	CENTURY EP 80			
	BELOW 0°C					
(Overseas)						
IN THE UNLIKELY EVENT OF THE ABOVE OILS NOT BEING AVAILABLE EQUIVALENT OILS SUPPLIED BY A REPUTABLE MANUFACTURER MAY BE USED						

RECOMMENDED LUBRICATING OILS

NEWAGE AXLES

COMPANY	ENGINE	NEWAGE DRIVE AXLE	HAMWORTHY DRIVE AXLE	TRANSFER BOX	GEARBOX	WHEEL BEARINGS & OTHER GREASE POINTS	HYDRAULIC SYSTEM	
(U.K.) ESSO (Overseas)	SUMMER WINTER ABOVE 32°C 0°C - 32°C BELOW 0°C	ESSOLUBE HDX 20W ESSOLUBE HDX 30 ESSOLUBE HDX 20W ESSOLUBE HDX 10W	TORQUE FLUID 62	IL 2082 IL 2082 IL 2082	GEAR OIL GP 85W/140 GEAR OIL GP 85W/140 GEAR OIL GP 85W/140 GEAR OIL GP 80W	ESSOLUBE HDX 30 ESSOLUBE HDX 30	BEACON 2 BEACON 2	NUTO H32 NUTO H68 NUTO H32 NUTO H22
(U.K.) CASTROL (Overseas)	SUMMER WINTER ABOVE 32°C 0°C - 32°C BELOW 0°C	DEUSOL CRI 20 DEUSOL CRI 30 DEUSOL CRI 20 DEUSOL CRI 10	AGRICASTROL AS AGRICASTROL AS SPECIAL	AGRICASTROL AS AGRICASTROL AS AGRICASTROL MD	DEUSOL EP 90 DEUSOL GEAR EP 140 DEUSOL GEAR EP 90 DEUSOL GEAR EP 80	DEUSOL CRI 30 DEUSOL CRI 30	CASTROL SPHEEROL APT 2 CASTROL SPHEEROL APT 2	CASTROL HYSPIN AWS 32
(U.K.) SHELL (Overseas)	SUMMER WINTER ABOVE 32°C 0°C - 32°C BELOW 0°C	ROTELLA SX OIL 20/20W ROTELLA SX OIL 30 ROTELLA SX OIL 20/20W ROTELLA SX OIL 10W	DONAX T12 (INITIAL FILL) SPIRAX EP 80 (Top up only) DONAX T12 (INITIAL FILL) SPIRAX EP 80 (Top up only) S.7224 (INITIAL FILL) SPIRAX HD 75 (Top up only)	SPIRAX 90 EP SPIRAX 140 EP SPIRAX 90 EP SPIRAX 80 EP	ROTELLA SX OIL 30 ROTELLA SX OIL 30	RETINAX A RETINAX A	TELLUS OIL 37	
(U.K.) BP (Overseas)	SUMMER WINTER ABOVE 32°C 0°C - 32°C BELOW 0°C	VANELLUS M20W VANELLUS M30 VANELLUS M20W VANELLUS M10W	B.P. HYDRAULIC TF-8 B.P. HYDRAULIC TF-8 B.P. TRACTRAN (Top up only)	GEAR OIL SAE 90 EP GEAR OIL SAE 140 EP GEAR OIL SAE 90 EP GEAR OIL SAE 80 EP	VANELLUS M30 VANELLUS M30	ENERGREASE L2 ENERGREASE L2	ENERGOL HLP 65	
(U.K.) MOBIL (Overseas)	SUMMER WINTER ABOVE 32°C 0°C - 32°C BELOW 0°C ALL TEMPERATURES	DELVAC 1220 DELVAC 1230 DELVAC 1220 DELVAC 1210 DELVAC SPECIAL 10W-30	MOBIL FLUID 422 MOBIL FLUID 422 MOBIL FLUID 427	MOBILUBE HD 90 MOBILUBE GX 90 MOBILUBE HD 140 MOBILUBE GX 140 MOBILUBE HD 90 MOBILUBE GX 90 MOBILUBE HD 80 MOBILUBE GX 80	DELVAC 1230 DELVAC 1230	MOBILGREASE MP MOBILGREASE SUPER	DTE 24	
(U.K.) WALKERS CENTURY (Overseas)	SUMMER WINTER CENTURY ABOVE 32°C 0°C - 32°C BELOW 0°C	CENTURY ROIL 20W 20 CENTURY ROIL 30 CENTURY ROIL 20W 20 CENTURY ROIL 10W	CENTLUBE F.76 COMPOUND CENTLUBE F.76 COMPOUND CENTLUBE E.76 COMPOUND	CENTURY EP 90 CENTURY EP 140 CENTURY EP 90 CENTURY EP 80	CENTURY ROIL 30 CENTURY ROIL 30	REGULUS A2 REGULUS A2	CENTURY PWL A HYD. OIL CENTURY PWL A HYD. OIL	

IN THE UNLIKELY EVENT OF THE ABOVE OILS NOT BEING AVAILABLE
EQUIVALENT OILS SUPPLIED BY A REPUTABLE MANUFACTURER MAY BE USED

OPERATING INSTRUCTIONS

ELECTRIC STARTING MACHINES

STARTING

1. Check that the Engine Stop Control knob is fully down.
2. Insert the ignition key in the isolating switch and turn clockwise.
3. Turn key further clockwise against spring load. DO NOT operate starter motor for more than 20 seconds at a time.
4. When engine is cold, "overload" may be required to facilitate starting and is set and returned to normal position as described in "Manual Starting" - see below.

STOPPING

Pull out stop control knob and hold fully out until engine stops. Release stop control knob when engine has ceased to turn. Turn key switch to OFF position.

MANUAL STARTING MACHINES

STARTING

(LISTER)

1. Pull out overload lever (situated on R.H. side of engine, above speed control arm) and lift to its highest position.

(PETTER)

1. Lift red-painted overload stop situated on the fuel pump rack above and to the rear of the priming levers and move fuel pump rack into fully open position. Operate priming levers six times. NOTE: This is unnecessary if engine is already warm.
2. Lift decompression lever(s) (positioned on top of engine) and turn engine as fast as possible using starting handle. When engine is turning at a good speed, knock down decompression levers and engine should fire.
3. If engine does not fire, lift decompression levers and slowly crank engine a few times before attempting to start again. Where ambient temperature is -15°C (5°F) or below, a cold starting aid should be fitted.
4. Set overload lever horizontal when engine starts. (LISTER)

STOPPING

Pull out stop control knob and hold fully out until engine stops. Push in stop control knob when engine has ceased to turn.

IMPORTANT

1. DO NOT stop engine by means of decompression levers, this will lead to damaged valve seats and cylinder head joints.
2. DO NOT stop engine by closing fuel tap or by allowing fuel tank to run dry, this will allow air into fuel lines and necessitate bleeding and priming system.

GEAR CHANGING - (FOUR B 30, FOUR B 40, FOUR B 50 & FOUR B 60)

The Dumper is fitted with three Forward and one Reverse gear. When changing gear, the clutch pedal is used in the normal way.

SKIP CONTROL LEVER (See Controls Layout)

1. Control lever has three positions DUMP (A), HOLD (B) and RETURN (C).
2. Push lever forward to DUMP (A) to deposit load.
3. Pull lever back to RETURN (C) to return skip to carrying position.

NOTE: If lever is released when in the DUMP or RETURN position, it will automatically return to HOLD (B) position and motion of skip will cease. In this way, speed at which load is deposited can be finely controlled.

ROTATING SKIP (IF FITTED)

Pull cranked release lever on turntable catch fully back to release turntable. Revolve skip to required position. To lock in position lift release lock lever and ensure that locking lug locates in turntable locking plate. Cranked release lever will return to its former position.

GENERAL MAINTENANCE

PERIODIC MAINTENANCE

DAILY check engine oil level and fill to full mark on dipstick, if necessary.

DAILY fill fuel tank, or as often as proves necessary to approximately 1" of top. Never allow there to be a depth of less than 2" of fuel in tank.

DAILY check tyre pressures and condition of tyres (refer to specification page).

WEEKLY check oil level in gearbox and fill to full mark on dipstick if necessary.

WEEKLY remove filler/level plugs from drive axles and transfer case. Oil level should be to bottom of holes. Top up if necessary through filler/level plugs.

WEEKLY check oil level in hydraulic tank. Always clean the surrounding area before removing cap to prevent possible entry of foreign matter. Fill tank, if necessary to 2" of top.

WEEKLY check that fittings are tight on feed pipe from hydraulic tank to master cylinder. Check for leaks.

WEEKLY apply grease to all grease nipples.



WEEKLY check all wheel nuts and tighten if necessary.

WEEKLY check all nuts and bolts and tighten if necessary.

EVERY SIX MONTHS repack steering column with water repellent grease.

IMPORTANT: CHANGE HYDRAULIC OIL FILTER ELEMENT AFTER FIRST 100 HOURS AND THEREAFTER EVERY 300 HOURS.

Lubrication

Period	Key	Description	Lubrication	No. of Points
Daily 	1	Engine	Engine Oil	1
	2	Fuel Tank	Diesel Fuel	1
Weekly 	3	Gearbox	Gearbox Oil	1
	4	Drive Axles	Axle Oil	2
	5	Hydraulic Tank	Hydraulic Oil	1
	6	Footbrake Pedal	Grease Gun	1
	7	Accelerator Pedal	Grease Gun	1
	8	Clutch Pedal	Grease Gun	1
	9	Clutch Cross Shaft	Grease Gun	2
	10	Skip Pivot	Grease Gun	2
	11	Handbrake Cable	Grease Gun	1
	12	Chassis Centre Pivot	Grease Gun	2
	13	Prop Shafts & Universal Joints	Grease Gun	10
	14	Transfer Case	Axle Oil	1
	15	Rear Axle Pivot	Grease Gun	1
6 Monthly 	16	Steering Column	Water Repellent Grease	1

NOTE: For full details of the lubrication and maintenance of the engine refer to Manufacturers Manual.

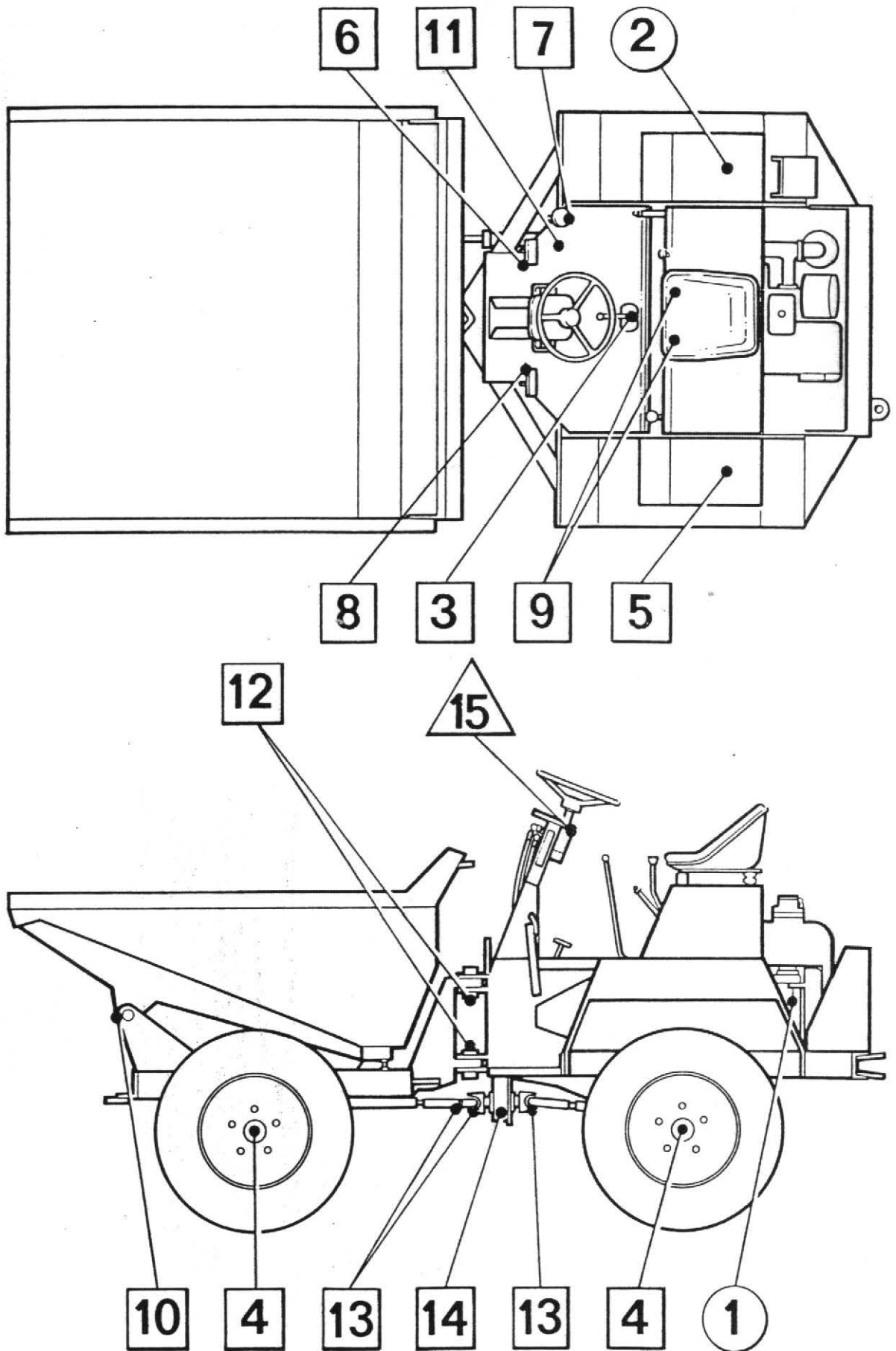

TP431

BRAKE SYSTEM (DISC BRAKES)

The brake system is designed to require the minimum of maintenance, and providing the hydraulic fluid in the reservoir is not allowed to fall below the recommended level, no defects should normally occur. Fluid loss must be supplemented by topping up the reservoir with Brake Fluid that conforms to SAE. J 1703. No other fluid may be used. If air is present in the system, it will be indicated by sluggish response of the brakes and by spongy action of the brake pedal. This may be due to air being introduced at a loose joint or by the reservoir fluid level being allowed to fall very low. These defects must be remedied immediately and the complete system bled.

To bleed the system, proceed as follows:-

1. Check that all connections are tight and all bleed screws are closed.
2. Fill reservoir with the correct fluid.
3. Attach bleeder tube (A) to one of the bleed screws (B) and immerse other end in a small quantity of brake fluid contained in a glass jar (C). Slacken bleed screw and operate brake pedal up and down to its full stroke until fluid pumped into the jar contains no air bubbles. Hold down pedal and close bleed screw. Remove bleeder tube and release pedal.
4. Repeat on other caliper.
5. Continue until all air has been bled from the system.
6. Lock both bleed screws and top up reservoir to the correct level.
7. Apply normal working load on brake pedal for two or three minutes and examine entire system for leaks.

NOTE: DURING THE OPERATION IT IS ESSENTIAL THAT THE RESERVOIR LEVELS ARE KEPT TOPPED UP TO PREVENT FURTHER AIR BEING DRAWN INTO THE SYSTEM. ONLY USE NEW FLUID FOR TOPPING UP.

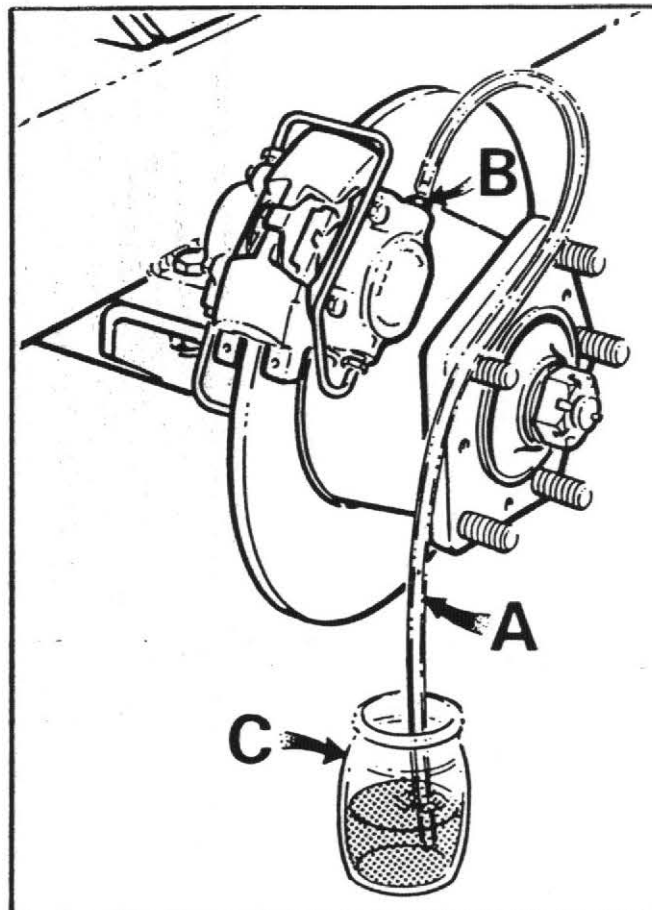

BRAKE SYSTEM (OIL IMMERSED BRAKES)

The brake system is designed to require the minimum of maintenance and no defects should normally occur. If air is present in the system, it will be indicated by sluggish response of the brakes and by spongy action of the brake pedal. This may be due to air being introduced at a loose joint. Any defects must be remedied immediately and the complete system bled.

To bleed the system, proceed as follows:-

1. Check that all connections are tight and the bleed screw is closed.
2. Check that there is sufficient oil in main hydraulic tank.
3. Attach bleeder tube (A) to the bleed screw (B) on the L.H. side of the front axle and immerse other end in a small quantity of hydraulic oil contained in a glass jar (C). Slacken bleed screw and operate brake pedal up and down to its full stroke, until oil pumped into the jar contains no air bubbles. Hold down pedal and close bleed screw. Remove bleeder tube and release pedal.
4. Lock the bleed screw.
5. Apply normal working load on brake pedal for two or three minutes and examine the entire system for leaks.

NOTE: ALWAYS ENSURE THAT FREE PLAY EXISTS BETWEEN BRAKE PEDAL AND MASTER CYLINDERS. UNLESS THE PISTONS IN BOTH MASTER CYLINDERS ARE ALLOWED TO FULLY RETURN, BRAKE PRESSURE WILL BUILD UP AND THE BRAKES WILL REMAIN ON.

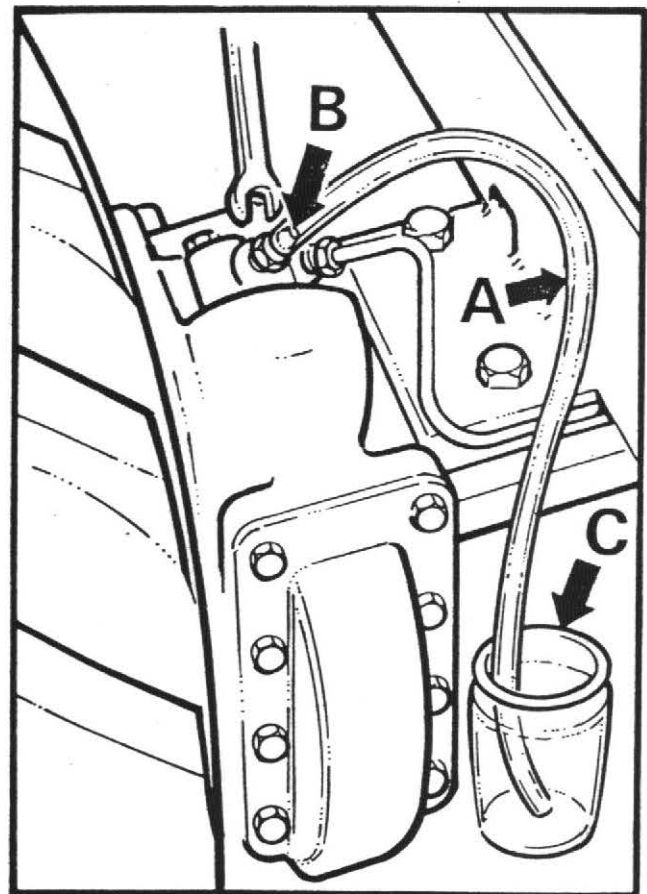
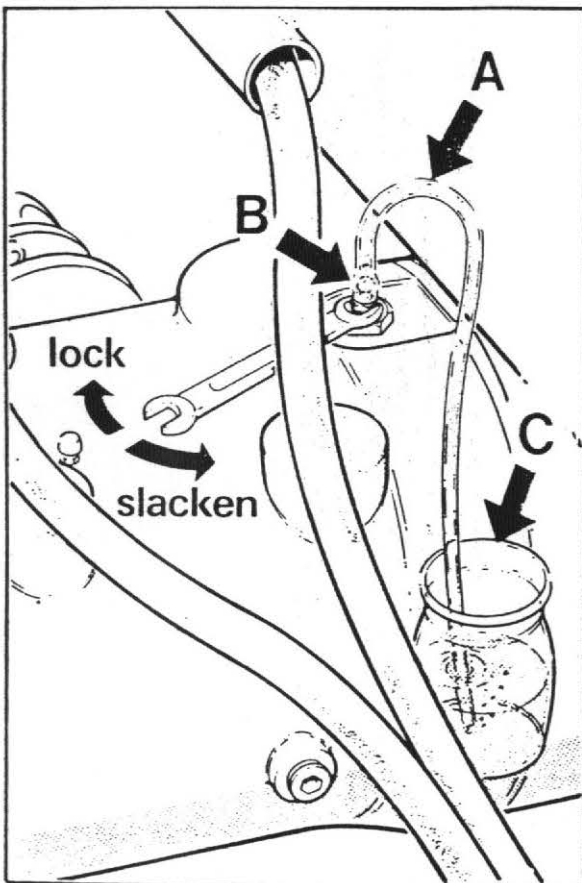

HYDRAULIC SYSTEM

The single hydraulic pump provides power for both the skip operation and steering. The main hydraulic valve splits the pump output into two circuits with controlled rate priority flow to steering circuit. If the hydraulic system fails to operate completely or does so extremely slowly carry out the following procedure.

1. Check that hydraulic tank is full of oil.
2. Check that the return line filter element has been regularly changed in accordance with the maintenance schedule. If not, change filter element. (E).
3. Check that the hydraulic pressures are correct.

TIP CIRCUIT

- a) Fit a 2000 lb/sq.in. gauge into the hydraulic system at the base of the skip ram.
- b) Operate control lever to dump skip and check that pressure reading on gauge is 1750 lb/sq.in. when ram is fully extended and relief valve is "blowing."

STEERING CIRCUIT

- a) Fit a 2000 lb/sq.in gauge into the hydraulic system at the base of the steering ram.
- b) Turn steering wheel with machine on "full lock" and check that the reading on the gauge is 1750 lb/sq.in.

NOTE: If correct pressure is not attained:

TIP CIRCUIT

4. Remove relief valve cartridge (A) (hexagon head) from the bottom of the control valve (B) and replace with a new one.
5. Remove hose adaptor (C) from control valve, remove hexagonal orifice plate (D) and wash in white spirit. Dry using moisture-free compressed air. DO NOT poke wire etc., into the orifice. Re-fit plate and hose adaptor with slot of orifice plate facing outwards.

STEERING CIRCUIT

6. Remove relief valve cartridge (A) (hexagon head) from the bottom of the control valve (B) and replace with a new one.

If none of these procedures correct the fault contact your Winget agent. Periodically check the hose between the pump and the tank to ensure it is not deformed. Any deformation in the hose may result in a restricted flow of fluid and damage to the pump.

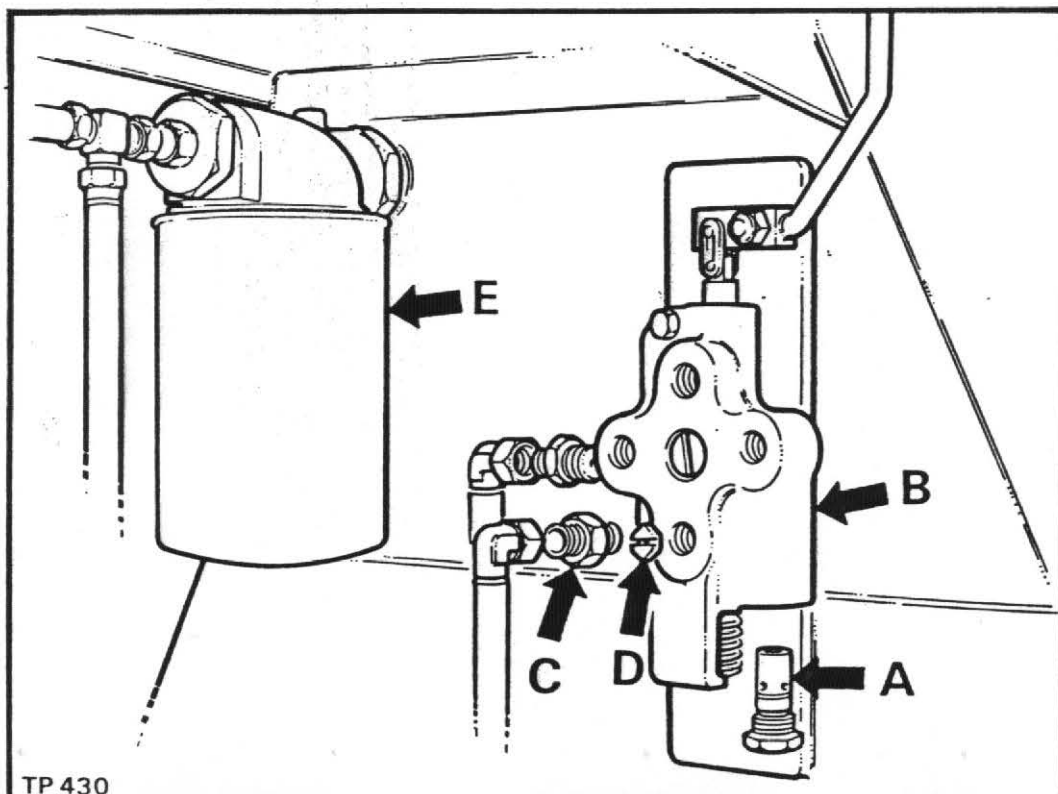

RECOMMENDED TORQUE FIGURES FOR FASTENERS

DESCRIPTION	TIGHTENING TORQUE	
	lb.ft.	Kg.m.
Bolt & Nut M6	8	(1.1)
Bolt & Nut M8	21	(3.0)
Bolt & Nut M10	42	(5.9)
Prop Shaft Bolts 3/8" UNF	29	(4.32)
Prop Shaft Bolts 7/16" UNF	46	(6.85)
Engine Bolts/Nuts M12	72	(10.7)
Axle Bolts ½" UNF	72	(10.7)
Wheel Nuts 5/8" BSF	180	(25)
Wheel Nuts 7/8" BSF	300	(42)
Wheel Nuts M18	200	(28)
Axle Bolts/Nuts M16	180	(26.8)
Steer Ram Nuts/Bolts 1¼" UNF/BSF	1080	(161.0)
Centre Pivot Nuts/Bolts 1½" UNF	1880	(279.7)

SPARE PARTS SECTION

LIST OF CONTENTS

TITLE	PAGE NO.
CHASSIS FRONT	23
CHASSIS REAR	24
DRIVE AXLE NEWAGE (OIL IMMERSSED BRAKES)	25-28
DRIVE AXLE SALISBURY (CALIPER BRAKES)	29-32
DRIVE AXLE SALISBURY (UNBRAKED)	33-36
DRIVE AXLE SALISBURY (OIL IMMERSSED BRAKES)	37-40
FLYWHEEL & CLUTCH	41
GEARBOX (NEWAGE AXLES)	42-45
GEARBOX (SALISBURY AXLES)	46-49
TRANSFER BOX	50-51
PROPSHAFTS	52
PEDAL CONTROLS	53-54
VALVE, CONTROL, HANDBRAKE & ENGNE STOP	55
HANDBRAKE CALIPER	56
BRAKE CALIPER	57
BRAKE MASTER CYLINDER (OIL IMMERSSED BRAKES)	58
BRAKE MASTER CYLINDER (CALIPER DISC BRAKES)	59
BRAKE PIPES AND FITTINGS (NEWAGE AXLES)	60
BRAKE PIPES AND FITTINGS (SALISBURY AXLES OIL IMMERSSED BRAKES)	61
BRAKE PIPES AND FITTINGS (SALISBURY AXLES CALIPER BRAKES)	62
HYDRAULIC RAM (ROTATING & TYPE A SKIP)	63
HYDRAULIC RAM (HIGH DISCHARGE SKIP)	64

STEERING RAM	65
HYDRAULIC RAM (TYPE B SKIP)	66
HYDRAULIC CONTROL VALVE	67
HYDRAULIC CIRCUIT HOSES & FITTINGS	68-71
EXHAUST SILENCERS	72
MUDGUARDS, TANKS & SEAT PLATES	73-74
AIR CLEANER (COOPERS)	75
AIR CLEANER (DONALDSON)	76
HIGH DISCHARGE SKIP	77
ROTATING SKIP	78-79
FORWARD TIPPING SKIP (TYPE B)	80
FORWARD TIPPING SKIP (TYPE A)	81
FUEL SYSTEM	82
WHEELS AND TYRES	83
ELECTRICAL SYSTEM (LISTER)	84
ELECTRICAL SYSTEM (PETTER)	85
LIGHTING KIT	86
LABELS & DECALS	87-88

FRONT CHASSIS

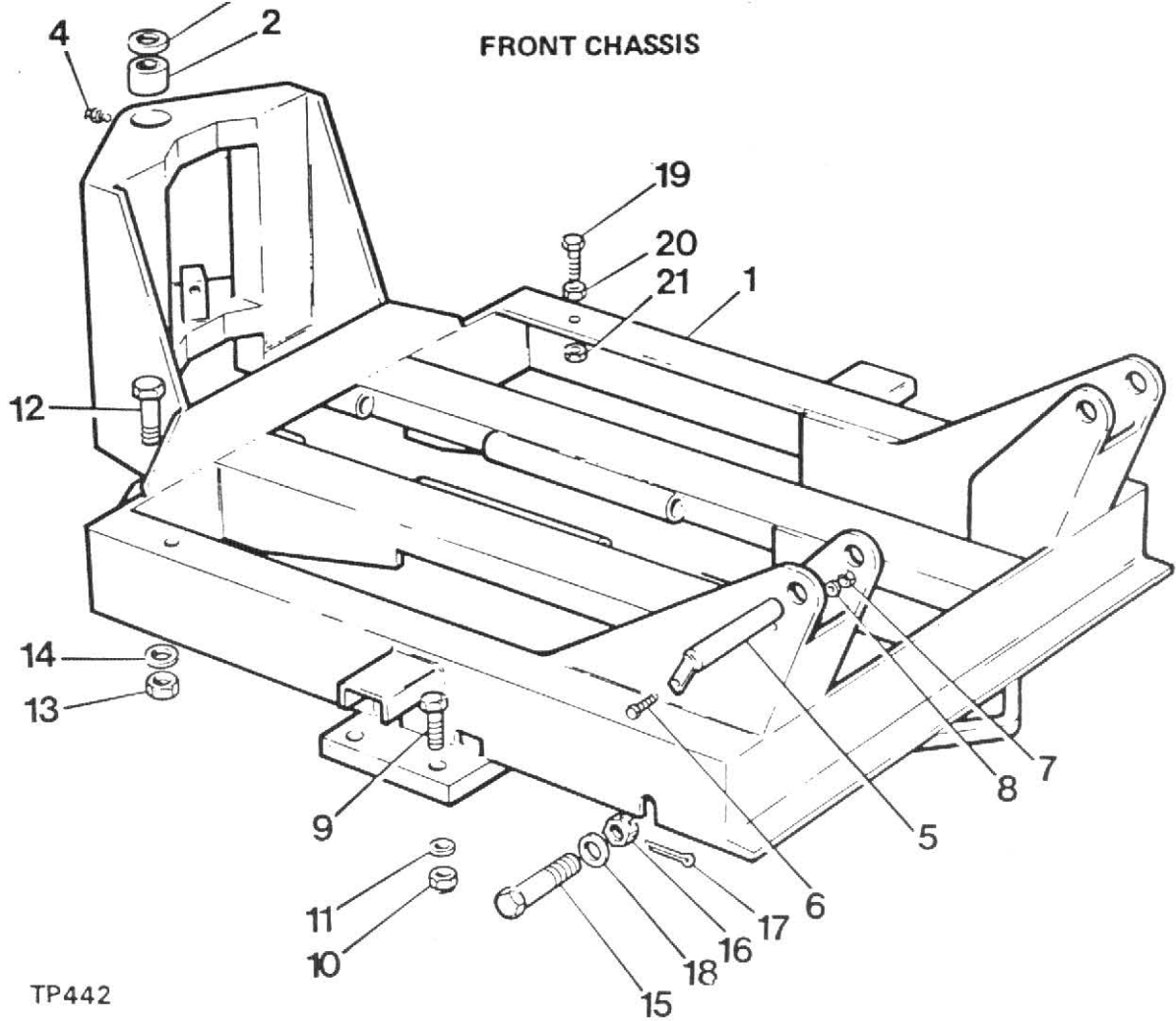

TP442

Item No.	Part No.	Description	Qty.
1	40100.A16	Chassis - Front. Fwd. Tip Skip) Salisbury	1
	40100.A17	Chassis - Front. Rotating Skip) Axles	1
	40100.A18	Chassis - Front. High Discharge Skip) Only	1
	40100.A20	Chassis - Front. Fwd. Tip Skip) Newage	1
	40100.A21	Chassis - Front. Rotating Skip) Axles	1
	40100.A22	Chassis - Front. High Discharge Skip) Only	1
2	4-60-214	Bearing - Centre Pivot	2
3	FSE 199	Spacer - Centre Pivot	4
4	131S.02	Nipple - Grease	2
5	10470.A01	Pin - Skip Pivot (Fwd. Tip only)	2
6	11S.04C	Bolt - Hex. Hd. M10 x 25	2
7	94S.04	Nut - M10	2
8	12S.05	Washer - Plain 10" I.D.	2
9	6S.05H	Bolt - ½" UNF x 2" Lg. Use with Axle 30242.A01 ...	8
	6S.05F	Bolt - ½" UNF x 1½" Lg. Use with Axle 30166.A01 ...	4
	8S.05F	Bolt - M12 x 50 Use with Axle 30156.A01	8
10	132S.05	Nut - ½" UNF Use with Axle 30242.A01	8
	132S.05	Nut - ½" UNF Use with Axle 30166.A01	4
	61S.05	Nut - M12 Use with Axle 30156.A01	8
11	10S.04	Washer - Plain ½" I.D. Use with ½" UNF Nuts	A/R
	12S.06	Washer - Plain 12 I.D. Use with M12 Nuts	8
12	10599.A01	Bolt - Steering Ram 1½" UNF x 4,3/8" Long	2
13	10600.A01	Nut - Steering Ram 1½" UNF	2
14	67S.13	Washer - Shakeproof - Internal 1½" I.D.	2
15	10352.A01	Bolt - Skip Ram Pivot. Fwd. Tip only	2
16	4-60-172	Nut - 1½" UNF Fwd. Tip only	2
17	44S.05H	Pin - Split 3/16" Dia. x 2½" Long Fwd. Tip only ...	2
18	10S.09	Washer - Plain 1½" I.D.	2
19	11S.07P	Screw M20 x 80mm Long	2
20	56S.07	Nut - half - M20	2
21	7S.07	Nut - Full - M20	2

REAR CHASSIS & ARTICULATING FRAME

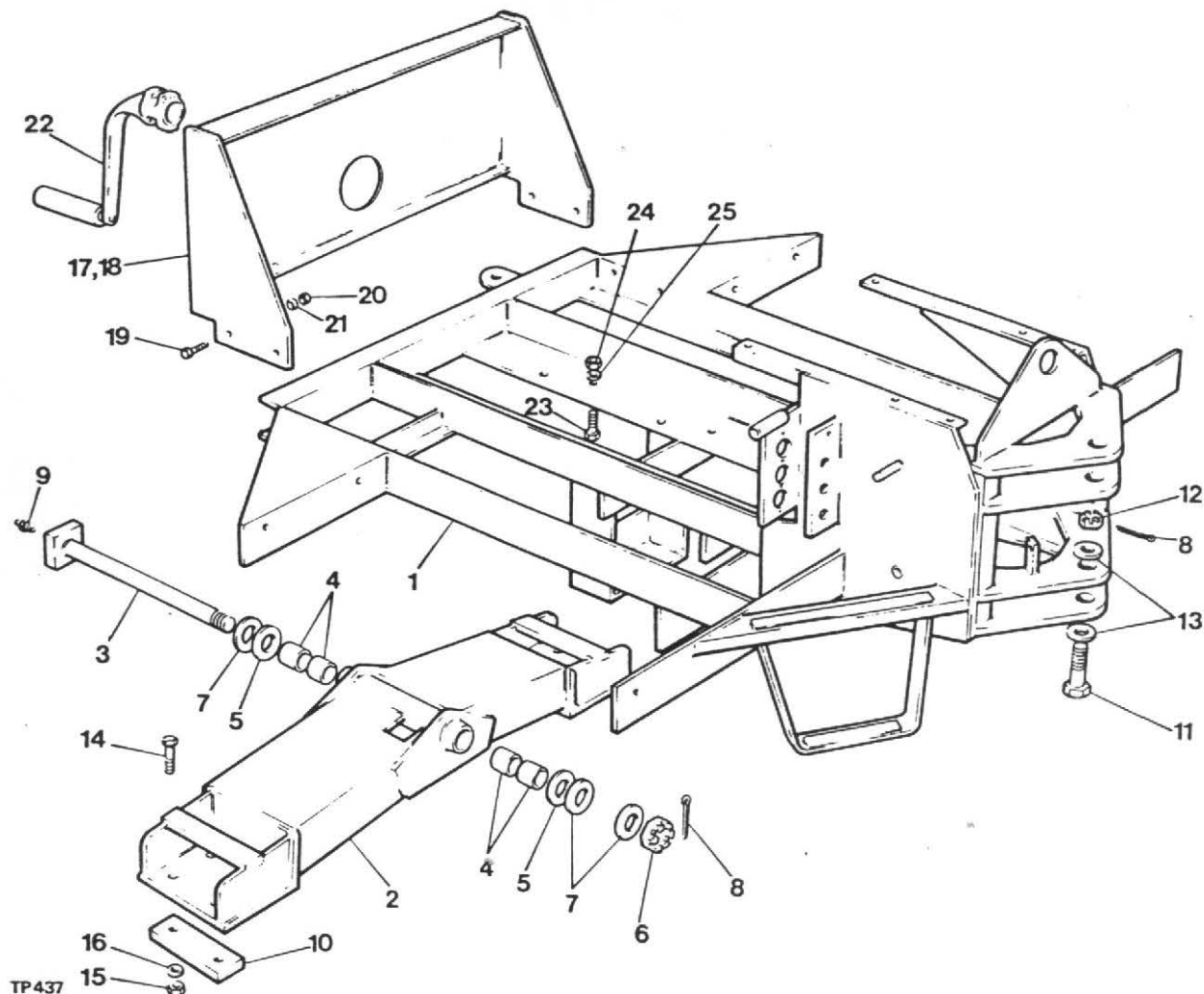

Item No.	Part No.	Description	Qty.
1	40101.A05	Chassis - Rear (Salisbury Axle)	1
	40101.A06	Chassis - Rear (Newage Axle)	1
2	30188.A02	Beam - Axle Pivot	1
3	20161.A03	Pin - Pivot	1
4	4-35-29B	Bush - Tension	4
5	4-35-29C	Washer - Thrust	2
6	102S14	Nut - Slotted 1½" UNF	1
7	ASE 178	Washer - Plain 1½" I.D.	3
8	44S.05L	Pin - Split 3/16" x 3" Long	2
9	131S.3	Nipple - Grease	1
10	10632.A02	Plate - Packing (Salisbury Axle only)	2
11	10375.A01	Bolt - Centre Pivot 1½" UNF x 4,3/8" Long	2
12	102S.14	Nut - Slotted 1½" UNF	1
13	10S.10	Washer - Plain - Centre Pivot	4
14	6S.5C	Bolt - ½" UNF x 1½" Lg. - Use with Axle 30166.A01.	4
	8S.05D	Bolt - M12 x 40 Lg. - Use with Axle 30156.A01	8
15	132S.5	Nut - ½" UNF - Use with Axle 30166.A01	4
	61S.05	Nut - M12 - Use with Axle 30156.A01	8
16	10S.04	Washer ½" I.D. - Use with ½" Nuts	4
	12S.06	Washer - 12 I.D. - Use with M12 Nuts	8
17	40105.A01	Frame - Rear (Petter Engine)	1
18		Frame - Rear (Lister Engine)	1
19	11S.04C	Bolt - Hex. Hd. M10 x 25	4
20	7S.04	Nut - M10	4
21	12S.05	Washer - Plain 10" I.D.	4
22	100A	Handle - Starting (Petter Engine)	1
	10467.A01	Handle - Starting (Lister Engine)	1
23	6S.05D	Bolt - Engine ½" UNF x 1,5/8" Long	4
24	132S.05	Nut - ½" UNF	4
25	10S.04	Washer - ½" I.D.	4

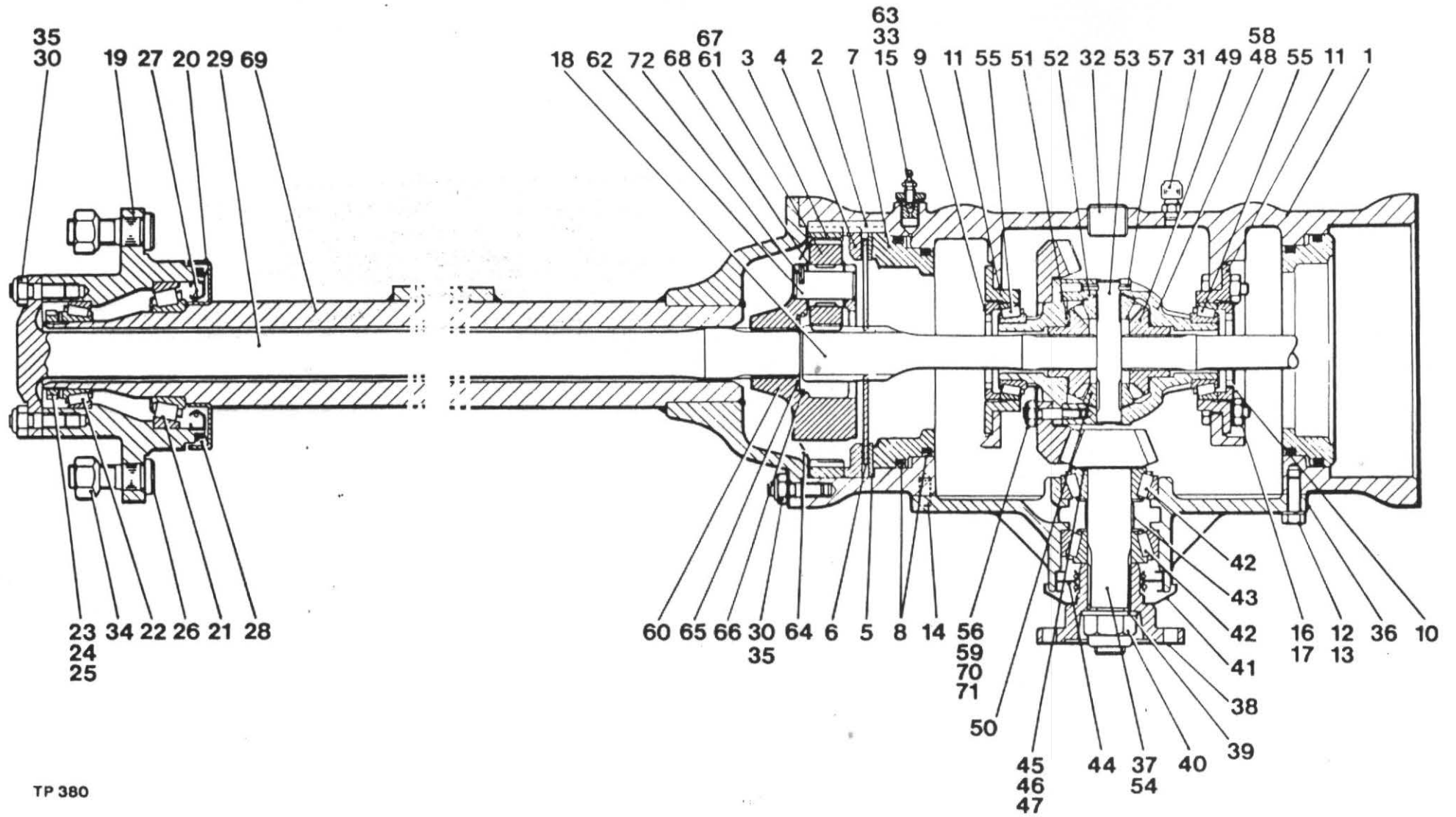

TP 380

DRIVE AXLE

Item No.	Part. No.	Description	Qty.
	30156.A01	Axle Complete	1
1	30156.A0101	Main Axle Casing	1
2	30156.A0102	Dowel Pin	4
3	30156.A0103	Annulus	2
4	30156.A0104	Brake Spacer Plate	2
5	30156.A0105	Brake Fixed Plate	2
6	30156.A0106	Oil Immersed Brake Disc	2
7	30156.A0107	Brake Piston	2
8	30156.A0108	Piston 'O' Ring Set	2
9	30156.A0109	Bearing Adj. Nut	2
10	30156.A0110	Bearing Adj. Nut Lock Plate	2
11	30156.A0111	Bearing Housing	2
12	11S.3C	Hex. Hd. Screw	12
13	17S.4	Spring Washer	12
14	30156.A0112	Dowel Pin	2
15	30156.A0113	Brake Pipe Adaptor	4
16	11S.4D	Hex. Hd. Screw	6
17	59S.03	Nyloc Nut	6
18	30156.A0114	Sun Gear	2
19	30156.A0115	Hub	2
20	30156.A0116	Oil Seal Housing	2
21	30082.A0221	Hub Inner Bearing	2
22	30156.A0118	Hub Outer Bearing	2
23	30156.A0119	Hub Bearing Spacer	2
24	30156.A0120	Bearing Lock Nut	2
25	30156.A0121	Tab Washer	2
26	30156.A0122	Wheel Stud	10
27	30156.A0123	Hub Oil Seal	2
28	30156.A0124	Hub 'V' Ring Seal	2
29	30156.A0125	Axle Shaft	2
30	30156.A0126	Stud	44
31	30082.A0214	Relief Valve	1
32	30082.A0212	Hex. Socket Plug	2
33	30082.A0215	Brake Bleed Valve	2
35	59S.03	Nyloc Nut	44
36	30156.A0129	Input Pinion Cartridge (Casing only).....	1
37	30156.A0130	Spiral Bevel Pinion	1
38	30156.A0131	Drive Flange	1
39	30082.A0231	Drive Flange Washer	1
40	30082.A0232	Drive Flange Nut	1
41	30156.A0134	Oil Seal Cover	1
42	30156.A0135	Pinion Bearing	2
43	30156.A0136	Pinion Bearing Spacer	1
44	30156.A0137	Pinion Oil Seal	1
45	30156.A0138	Pinion Adj. Shim	A/R
46	30156.A0139	Pinion Adj. Shim	A/R
47	30156.A0140	Pinion Adj. Shim	A/R
48	30156.A0142	Diff. Case (L.H.)	1
49	30156.A0143	Diff. Wheel	2
50	30082.A0240	Diff. Pinion	2
51	30156.A0144	Diff. Wheel Thrust Washer	2

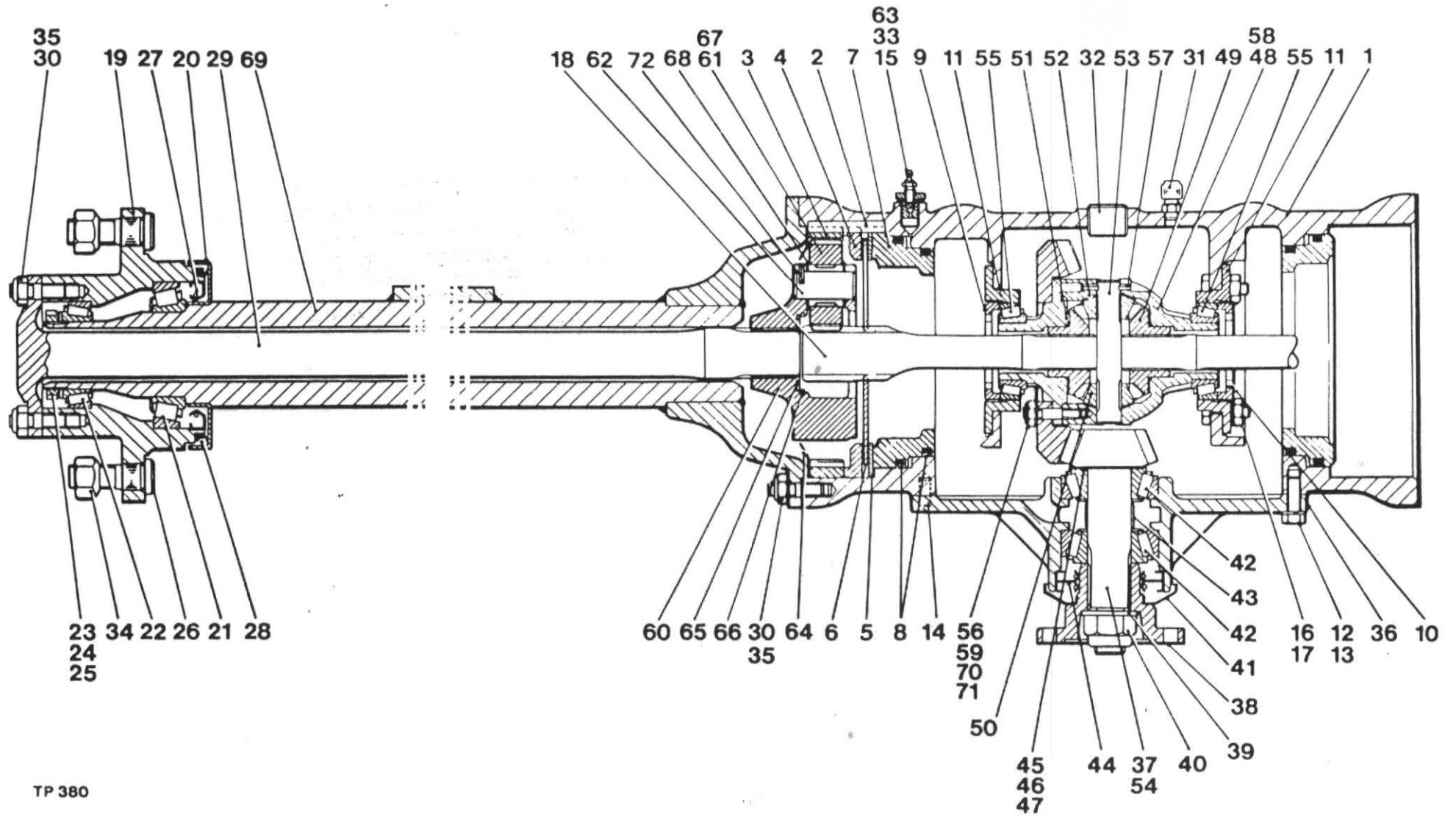

DRIVE AXLE (Cont'd)

Item No.	Part No.	Description	Qty.
52	30156.A0145	Diff. Pinion Thrust Washer	2
53	30156.A0146	Diff. Spider	1
54	30156.A0147	Spiral Bevel Wheel	1
55	30082.A0244	Diff. Bearing	2
56	30156.A0148	Stud	10
57	30156.A0149	Spring Dowel	1
58	30156.A0150	Diff. Case (R.H.)	1
59	30156.A0151	Tab Washer	1
60	30156.A0152	Planet Carrier	1
61	30156.A0153	Planet Gear	3
62	30156.A0154	Planet Pin	3
63	30156.A0155	Washer	4
64	30156.A0156	Shield	2
65	30156.A0157	Axle Shaft Thrust Spacer	1
66	30156.A0158	Circlip	1
67	30156.A0159	Planet Cage Roller	3
68	30082.A0249	Planet Thrust Washer	6
69	30156.A0160	Axle Arm	2
70	30156.A0161	Tab Washer	4
71	7S.4	Nut	10
72	30156.A0162	Spring Dowel	3

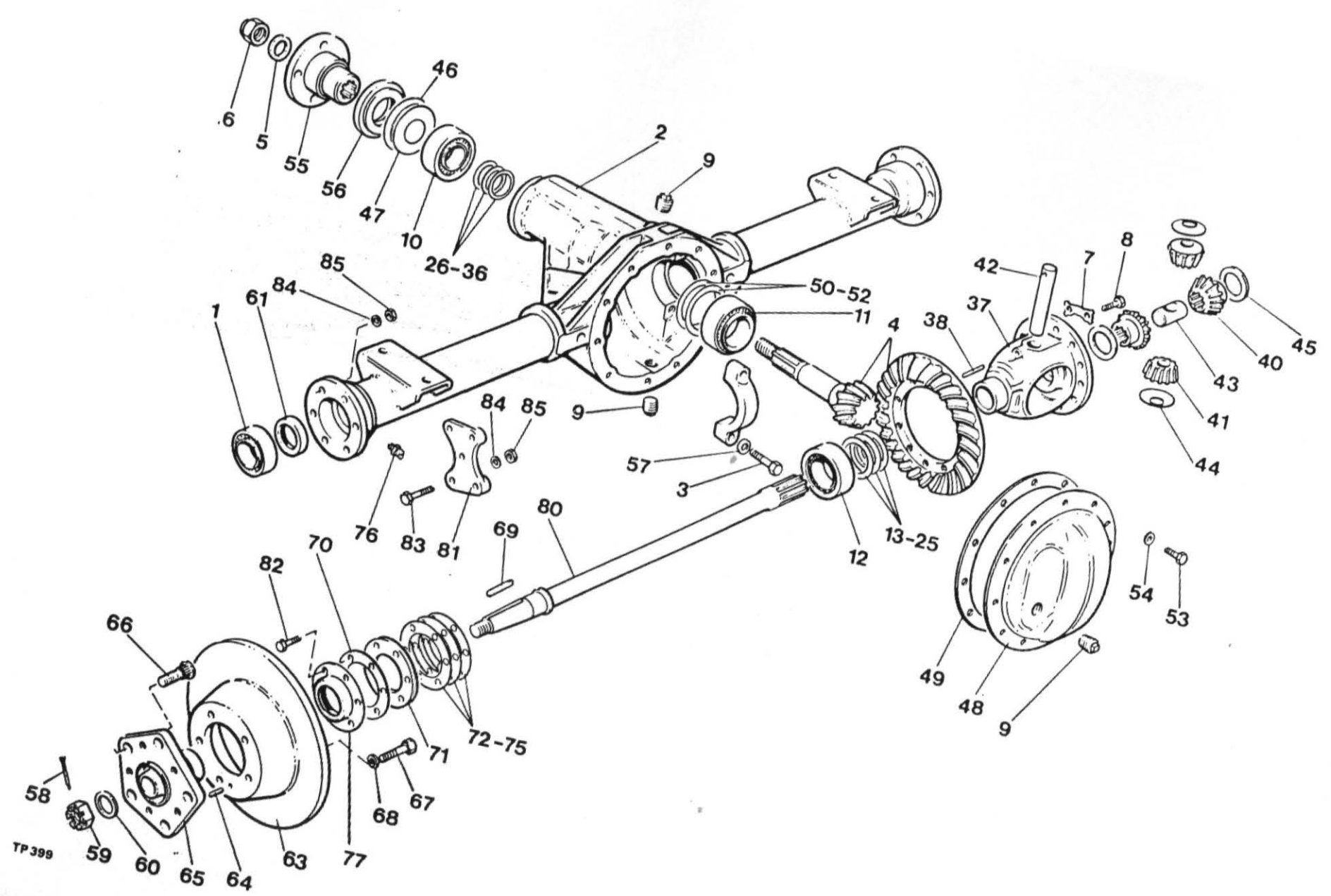

TP 399

DRIVE AXLE

Item No.	Part No.	Description	Qty. per axle
	30166.A01	Drive Axle complete	1
1	30166.A0101	Bearing	2
2	30166.A0102	Carrier & Tube Assy. (Incl. item 3)	1
3	30166.A0103	Bolt - Differential Bearing Cap	4
4	30166.A0104	Gear & Pinion Assy. (Incl. items 5-8)	1
5	30166.A0105	Washer	1
6	30166.A0106	Pinion Locknut	1
7	30166.A0107	Drive Gear Lockstrap	6
8	30166.A0108	Drive Gear Bolt	12
9	30166.A0109	Level Filler Plug	3
10	30166.A0110	Bearing	1
11	30166.A0111	Bearing	1
12	30166.A0112	Bearing	1
13	30166.A0113	Differential Bearing Shim .028"	A/R
14	30166.A0114	Differential Bearing Shim .030"	A/R
15	30166.A0115	Differential Bearing Shim .031"	A/R
16	30166.A0116	Differential Bearing Shim .032"	A/R
17	30166.A0117	Differential Bearing Shim .033"	A/R
18	30166.A0118	Differential Bearing Shim .034"	A/R
19	30166.A0119	Differential Bearing Shim .035"	A/R
20	30166.A0120	Differential Bearing Shim .036"	A/R
21	30166.A0121	Differential Bearing Shim .037"	A/R
22	30166.A0122	Differential Bearing Shim .038"	A/R
23	30166.A0123	Differential Bearing Shim .039"	A/R
24	30166.A0124	Differential Bearing Shim .040"	A/R
25	30166.A0125	Differential Bearing Shim .045"	A/R
26	30166.A0126	Outer Pinion Bearing Shim .030"	A/R
27	30166.A0127	Outer Pinion Bearing Shim .031"	A/R
28	30166.A0128	Outer Pinion Bearing Shim .032"	A/R
29	30166.A0129	Outer Pinion Bearing Shim .033"	A/R
30	30166.A0130	Outer Pinion Bearing Shim .034"	A/R
31	30166.A0131	Outer Pinion Bearing Shim .035"	A/R
32	30166.A0132	Outer Pinion Bearing Shim .036"	A/R
33	30166.A0133	Outer Pinion Bearing Shim .037"	A/R
34	30166.A0134	Outer Pinion Bearing Shim .038"	A/R
35	30166.A0135	Outer Pinion Bearing Shim .039"	A/R
36	30166.A0136	Outer Pinion Bearing Shim .040"	A/R
37	30166.A0137	Differential Case Assy.(Incl. items 38-45)	1
38	30166.A0138	Roll Pin	1
39	30166.A0139	Differential Case	1
40	30166.A0140	Differential Side Gear	2
41	30166.A0141	Differential Pinion Mate	2
42	30166.A0142	Differential Pinion Mate Shaft	1
43	30166.A0143	Axle Shaft Spacer	1
44	30166.A0144	Differential Pinion Mate Thrust Washer	2
45	30166.A0145	Differential Side Gear Thrust Washer	2
46	30166.A0146	Pinion Oil Seal Gasket	1
47	30166.A0147	Pinion Oil Slinger	1
48	30166.A0148	Gear Carrier Cover	1
49	30166.A0149	Cover Gasket	1
50	30166.A0150	Inner Pinion Bearing Shim .003"	A/R
51	30166.A0151	Inner Pinion Bearing Shim .005"	A/R
52	30166.A0152	Inner Pinion Bearing Shim .010"	A/R
53	30166.A0153	Carrier Cover Bolt	10
54	30166.A0154	Lockwasher	10
55	30166.A0155	Companion Flange	1
56	30166.A0156	Pinion Oil Seal	1
57	30166.A0157	Differential Bearing Cap Lockwasher	4

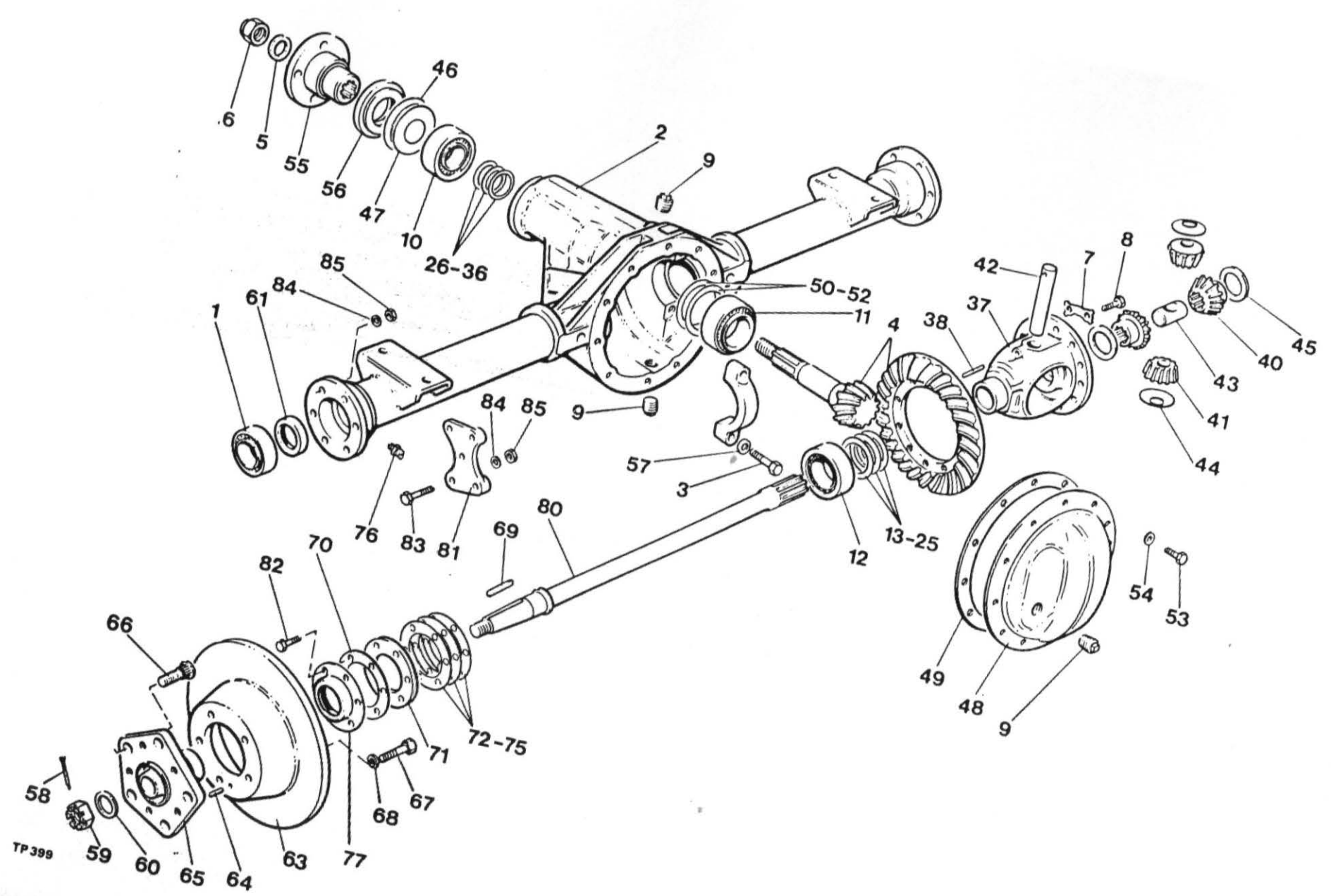

TP 399

DRIVE AXLE (Cont'd.)

Item No.	Part No.	Description	Qty. per axle
58	30166.A0158	Shaft Cotter	2
59	30166.A0159	Shaft Nut	2
60	30166.A0160	Shaft Washer	2
61	30166.A0161	Axle Shaft Oil Seal	2
62	30166.A0162	Axle Shaft Oil Seal	2
63	30166.A0163	Brake Disc	2
64	30166.A0164	Roll Pin	4
65	30166.A0165	Hub & Stud Assy. (Incl. item 66)	2
66	30166.A0166	Wheel Stud	10
67	30166.A0167	Brake Disc Bolt	10
68	30166.A0154	Lockwasher	10
69	30166.A0169	Axle Shaft Key	2
70	30166.A0170	Hub Oil Seal Gasket	2
71	30166.A0171	Retainer Plate	2
72	30166.A0172	Wheel Bearing Shim .003"	A/R
73	30166.A0173	Wheel Bearing Shim .005"	A/R
74	30166.A0174	Wheel Bearing Shim .010"	A/R
75	30166.A0175	Wheel Bearing Shim .030"	A/R
76	30166.A0176	Grease Nipple	2
77	30166.A0177	Hub Oil Seal Assy.(Incl. items 78-79)	2
78		Hub Oil Seal Container .Only available	1
79		Hub Oil Seal as assembly	1
80	30166.A0180	Axle Shaft	2
81	30166.A0181	Caliper Bracket	2
82	30166.A0182	Brake Back Plate Bolt	6
83	30166.A0183	Caliper Mounting Plate Bolt	6
84	30166.A0154	Lockwasher	12
85	30166.A0185	Brake Back Plate Nut	12

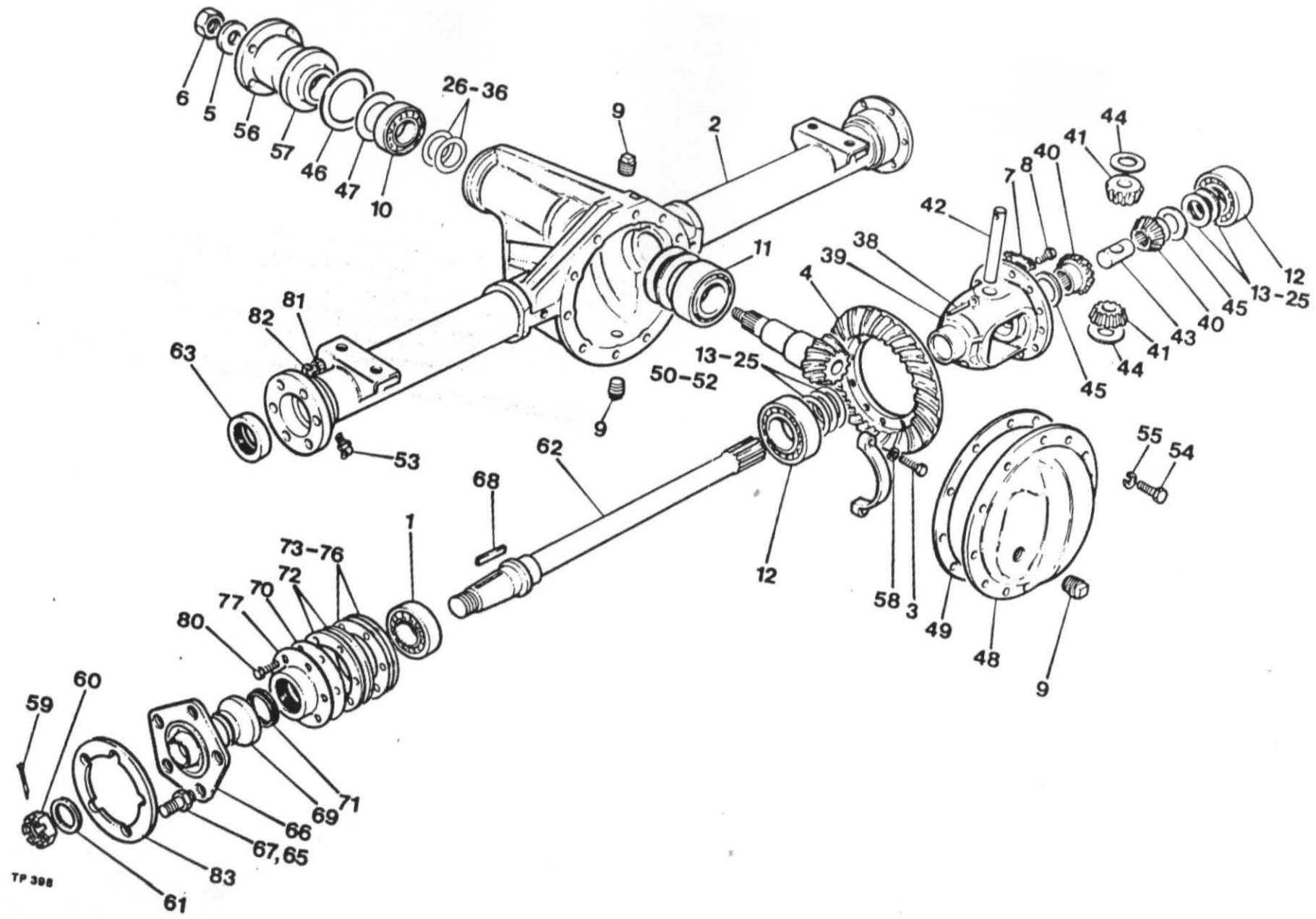

TP 398

DRIVE AXLE

Item No.	Part No.	Description	Qty. per axle
	30171.A01	Drive Axle complete	1
1	30166.A0101	Bearing	2
2	30171.A0101	Carrier & Tube Assy.(Incl. item 3)	1
3	30166.A0103	Bolt - Diff. Bearing Cap	4
4	30166.A0104	Gear Assembly (including items 5-8)	1
5	30166.A0105	Washer	1
6	30166.A0106	Locknut - Pinion	1
7	30166.A0107	Drive Gear L Strap	6
8	30166.A0108	Drive Gear Bolt	12
9	30166.A0109	Level Filler Plug	3
10	30166.A0110	Bearing	1
11	30166.A0111	Bearing	1
12	30166.A0112	Bearing	2
13	30166.A0113	Shim Diff. Bearing .028"	A/R
14	30166.A0114	Shim Diff. Bearing .030"	A/R
15	30166.A0115	Shim Diff. Bearing .031"	A/R
16	30166.A0116	Shim Diff. Bearing .032"	A/R
17	30166.A0117	Shim Diff. Bearing .033"	A/R
18	30166.A0118	Shim Diff. Bearing .034"	A/R
19	30166.A0119	Shim Diff. Bearing .035"	A/R
20	30166.A0120	Shim Diff. Bearing .036"	A/R
21	30166.A0121	Shim Diff. Bearing .037"	A/R
22	30166.A0122	Shim Diff. Bearing .038"	A/R
23	30166.A0123	Shim Diff. Bearing .039"	A/R
24	30166.A0124	Shim Diff. Bearing .040"	A/R
25	30166.A0125	Shim Diff. Bearing .045"	A/R
26	30166.A0126	Shim Pinion Bearing Out .030"	A/R
27	30166.A0127	Shim Pinion Bearing Out .031"	A/R
28	30166.A0128	Shim Pinion Bearing Out .032"	A/R
29	30166.A0129	Shim Pinion Bearing Out .033"	A/R
30	30166.A0130	Shim Pinion Bearing Out .034"	A/R
31	30166.A0131	Shim Pinion Bearing Out .035"	A/R
32	30166.A0132	Shim Pinion Bearing Out .036"	A/R
33	30166.A0133	Shim Pinion Bearing Out .037"	A/R
34	30166.A0134	Shim Pinion Bearing Out .038"	A/R
35	30166.A0135	Shim Pinion Bearing Out .039"	A/R
36	30166.A0136	Shim Pinion Bearing Out .040"	A/R
37	30166.A0137	Diff. Case Assy. 2P Spacer (Incl. items 38-45)...	1
38	30166.A0138	Roll Pin	1
39	30166.A0139	Diff. Case 2 Pin	1
40	30166.A0140	Diff. Side Gear	2
41	30166.A0141	Diff. Pinion Mate	2
42	30166.A0142	Diff. Pinion Mate Shaft	1
43	30166.A0143	Axle Shaft Spacer	1
44	30166.A0144	Diff. Pinion Mate T Washer	2
45	30166.A0145	Diff. Side Gear T Washer	2
46	30166.A0146	Pinion Oil Seal Gasket	1
47	30166.A0147	Pinion Oil Slinger	1
48	30166.A0148	Gear Carrier Cover	1
49	30166.A0149	Carrier Cover Gasket	1
50	30166.A0150	Pin Bearing Shim In. .003"	A/R
51	30166.A0151	Pin Bearing Shim In. .005"	A/R
52	30166.A0152	Pin Bearing Shim In. .010"	A/R
53	30166.A0176	Grease Nipple	2
54	30166.A0153	Carrier Cover Bolt	10
55	30166.A0154	Lockwasher	10
56	30166.A0155	Companion Flange.....	1

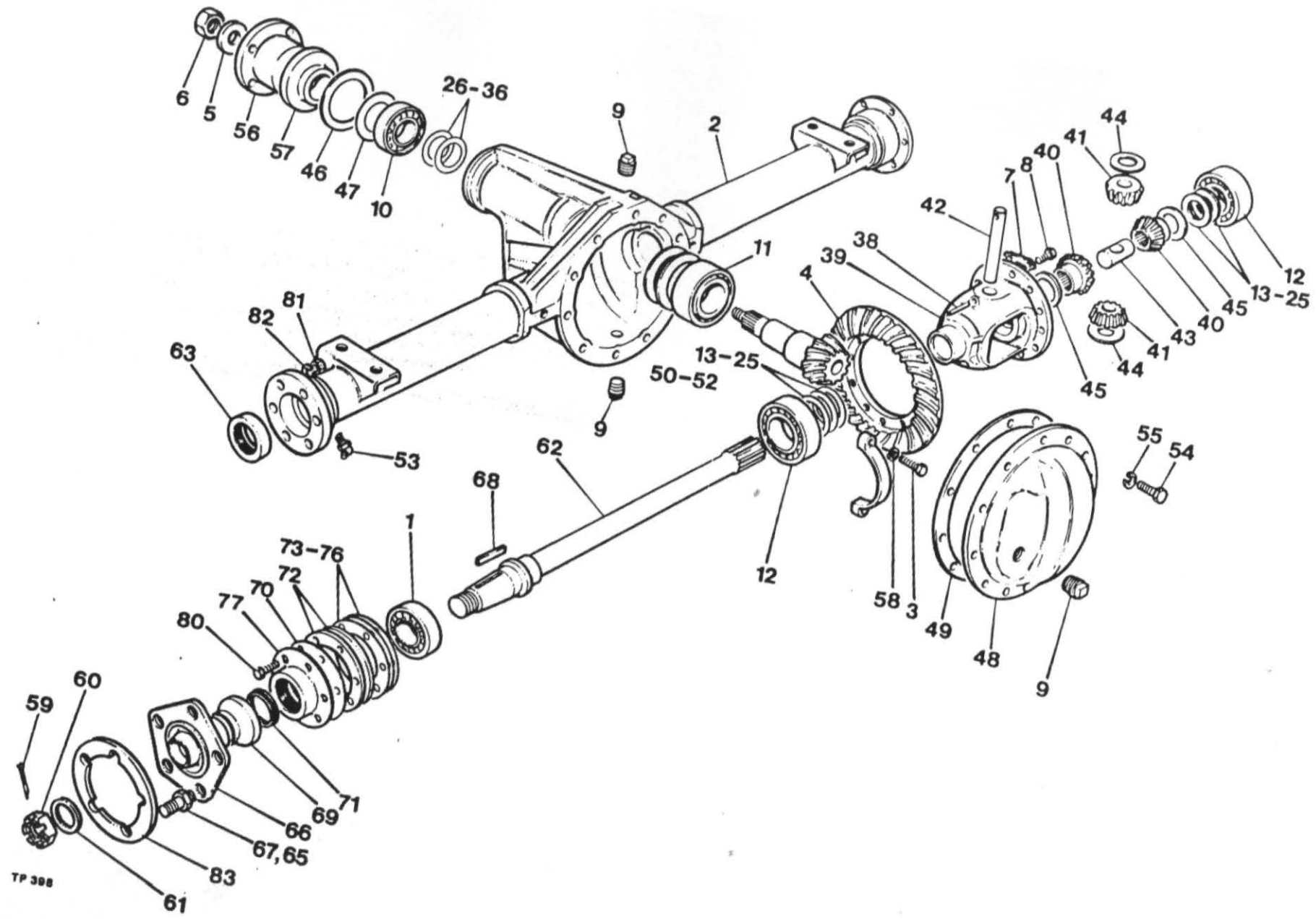

TP 398

DRIVE AXLE (Cont'd)

Item No.	Part No.	Description	Qty. per axle
57	30166.A0156	Pinion Oil Seal	1
58	30166.A0157	Lockwasher - Diff. Bearing Cap	4
59	30166.A0158	Cotter - Shaft	2
60	30166.A0159	Shaft Nut	2
61	30166.A0160	Washer - Shaft	2
62	30166.A0180	Axle Shaft	2
63	30166.A0161	Axle Shaft Oil Seal	2
64	30171.A0102	Wheel Hub Assy.(Incl. items 65-67)	2
65	30171.A0103	Stud Locking Dowel	10
66	30171.A0104	Wheel Hub	2
67	30171.A0105	Wheel Stud	10
68	30166.A0169	Axle Shaft Key	2
69	30171.A0106	V-Ring Housing	2
70	30166.A0170	Hub Oil Seal Gasket	2
71	30171.A0107	V-Ring	2
72	30171.A0108	Retainer Plate	4
73	30166.A0172	Wheel Bearing Shim .003"	A/R
74	30166.A0173	Wheel Bearing Shim .005"	A/R
75	30166.A0174	Wheel Bearing Shim .010"	A/R
76	30166.A0175	Wheel Bearing Shim .030"	A/R
77	30166.A0177	Hub Oil Seal Assembly (Incl. items 78 & 79)	2
78		Hub Oil Seal Container . Only available	2
79		Hub Oil Seal as assembly	2
80	30166.A0167	Brake Back Plate Bolt	12
81	30171.A0109	Brake Backplate Locknut	12
82	30171.A0110	Brake Backplate Washer	12
83	ASE 127	Spacer	2

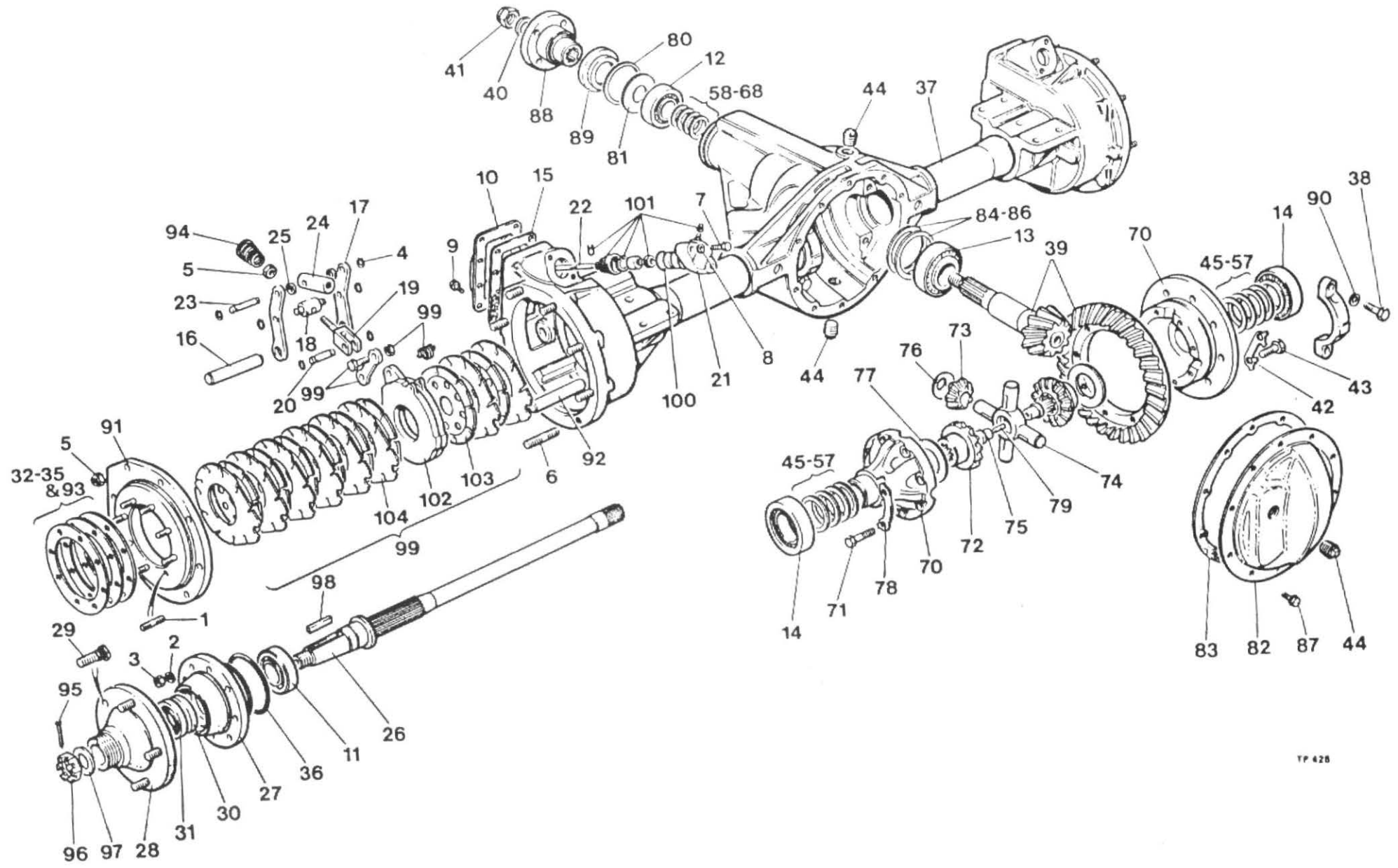

DRIVE AXLE

Item No.	Part No.	Description	Qty. per Axle
	30242.A01	Drive Axle complete	1
1	30242.A0101	Stud - Nylon Patch Locking	16
2	30242.A0102	Lockwasher	16
3	30242.A0103	Nut	16
4	30242.A0104	Circlip	12
5	30242.A0105	Locknut	18
6	30242.A0106	Stud	16
7	30242.A0107	Bolt	4
8	30242.A0108	Lockwasher	4
9	30242.A0109	Washer Bolt	16
10	30242.A0110	Cover - Brake Link Access	2
11	30242.A0111	Bearing	2
12	30166.A0110	Bearing	1
13	30166.A0111	Bearing	1
14	30166.A0112	Bearing	2
15	30242.A0112	Gasket - Brake Housing Cover	2
16	30242.A0113	Brake Pin	2
17	30242.A0114	Lever - Brake Operating	4
18	30242.A0115	Trunion	2
19	30242.A0116	Clevis	2
20	30242.A0117	Clevis Pin	2
21	30242.A0118	Slave Cylinder (Complete with item 22) .	2
22	30242.A0119	Push Rod	1
23	30242.A0120	Trunion	2
24	30242.A0121	Push Rod - Sleeve	2
25	30242.A0122	Pivot Spacer	4
26	30242.A0123	Axle Shaft	2
27	30242.A0124	Bearing Housing	2
28	30242.A0125	Hub & Stud Assy (Complete with item 29)	2
29	30166.A0166	Wheel Stud	5
30	30242.A0127	Oil Seal (Rubber)	2
31	30242.A0153	Oil Seal (Leather)	2
32	30242.A0128	Shim - Wheel Bearing 0.08U	2
33	30242.A0129	Shim - Wheel Bearing 0.125U	2
34	30242.A0130	Shim - Wheel Bearing 0.25U	2
35	30242.A0131	Shim - Wheel Bearing 0.8U	2
36	30242.A0132	'O' Ring	2
37	30242.A0133	Carrier & Tube Brake Housing Assy. (Complete with items 38 & 90).....	1
38	30166.A0103	Bolt - Diff. Brg. Cap	4
39	30166.A0104	Gear Assy. U/L 6.38/1 (Complete with items 40-43)	1
40	30166.A0105	Washer	1
41	30166.A0106	Locknut - Pinion	1
42	30166.A0107	Lock Strap - Drive Gear	6
43	30166.A0108	Bolt - Drive Gear	12
44	30166.A0109	Plug - Level Filler	3
45	30166.A0113	Shim - Diff. Brg. .028"	2
46	30166.A0114	Shim - Diff. Brg. .030"	2
47	30166.A0115	Shim - Diff. Brg. .031"	2
48	30166.A0116	Shim - Diff. Brg. .032"	2
49	30166.A0117	Shim - Diff. Brg. .033"	2
50	30166.A0118	Shim - Diff. Brg. .034"	2
51	30166.A0119	Shim - Diff. Brg. .035"	2
52	30166.A0120	Shim - Diff. Brg. .036"	2
53	30166.A0121	Shim - Diff. Brg. .037"	2
54	30166.A0122	Shim - Diff. Brg. .038"	2
55	30166.A0123	Shim - Diff. Brg. .039"	2
56	30166.A0124	Shim - Diff. Brg. .040"	2
57	30166.A0125	Shim - Diff. Brg. .045"	2

DRIVE AXLE (Contd.)

Item No.	Part No.	Description	Qty. per Axle
58	30166.A0126	Shim - Outer Pinion Bearing .030"	2
59	30166.A0127	Shim - Outer Pinion Bearing .031"	2
60	30166.A0128	Shim - Outer Pinion Bearing .032"	2
61	30166.A0129	Shim - Outer Pinion Bearing .033"	2
62	30166.A0130	Shim - Outer Pinion Bearing .034"	2
63	30166.A0131	Shim - Outer Pinion Bearing .035"	2
64	30166.A0132	Shim - Outer Pinion Bearing .036"	2
65	30166.A0133	Shim - Outer Pinion Bearing .037"	2
66	30166.A0134	Shim - Outer Pinion Bearing .038"	2
67	30166.A0135	Shim - Outer Pinion Bearing .039"	2
68	30166.A0136	Shim - Outer Pinion Bearing .040"	2
69	30242.A0134	Diff. Case Assy. 4P Spacer (Complete with items 70-79)	1
70	30242.A0135	Diff. Case Sub Assy.	1
71	30242.A0136	Bolt - Diff. Case	8
72	30242.A0137	Side Gear	2
73	30242.A0138	Pinion Mate	4
74	30242.A0139	Cross Shaft - Pinion Mate	1
75	30242.A0140	Split Spacer - Axle Shaft	2
76	30242.A0141	Thrust Washer - Diff. Pinion Mate	4
77	30242.A0142	Thrust Washer - Diff. Side Gear	2
78	30242.A0143	Lock Strap - Diff. Case	4
79	30242.A0144	Roll Pin	1
80	30166.A0146	Gasket - Pinion Oil Seal	1
81	30166.A0147	Oil Slinger - Pinion	1
82	30242.A0145	Cover - Gear Carrier	1
83	30166.A0149	Gasket - Carrier Cover	1
84	30166.A0150	Shim - Pinion Bearing - Inner .003" ...	2
85	30166.A0151	Shim - Pinion Bearing - Inner .005" ...	2
86	30166.A0152	Shim - Pinion Bearing - Inner .010" ...	2
87	30242.A0146	Bolt & Washer Assy.	10
88	30166.A0155	Companion Flange	1
89	30166.A0156	Pinion Oil Seal	1
90	30166.A0157	Lockwasher - Diff. Brg. Cap	4
91	30242.A0147	Brake Cover & Spindle Housing	2
92	30242.A0148	Brake Anchor Pin	2
93	30242.A0149	Shim Spacer 2.5U	2
94	30242.A0150	Conical Return Spring	2
95	30166.A0158	Cotter - Shaft	2
96	30166.A0159	Nut - Shaft	2
97	30166.A0160	Washer - Shaft	2
98	30166.A0169	Key - Shaft	2
99	30242.A0152	Brake Assy. & Disc (8 Plate)	2
100	30242.A0154	'O' Ring - Slave Cylinder Seal	2
101	30242.A0155	Seal Kit - Slave Cylinder	A/R
102	30242.A0156	Actuator	2
103	30242.A0157	Brake Middle Plate	16
104	30242.A0158	Brake Intermediate Plate	16
105	30242.A0159	SPRING.	

FLYWHEEL AND CLUTCH

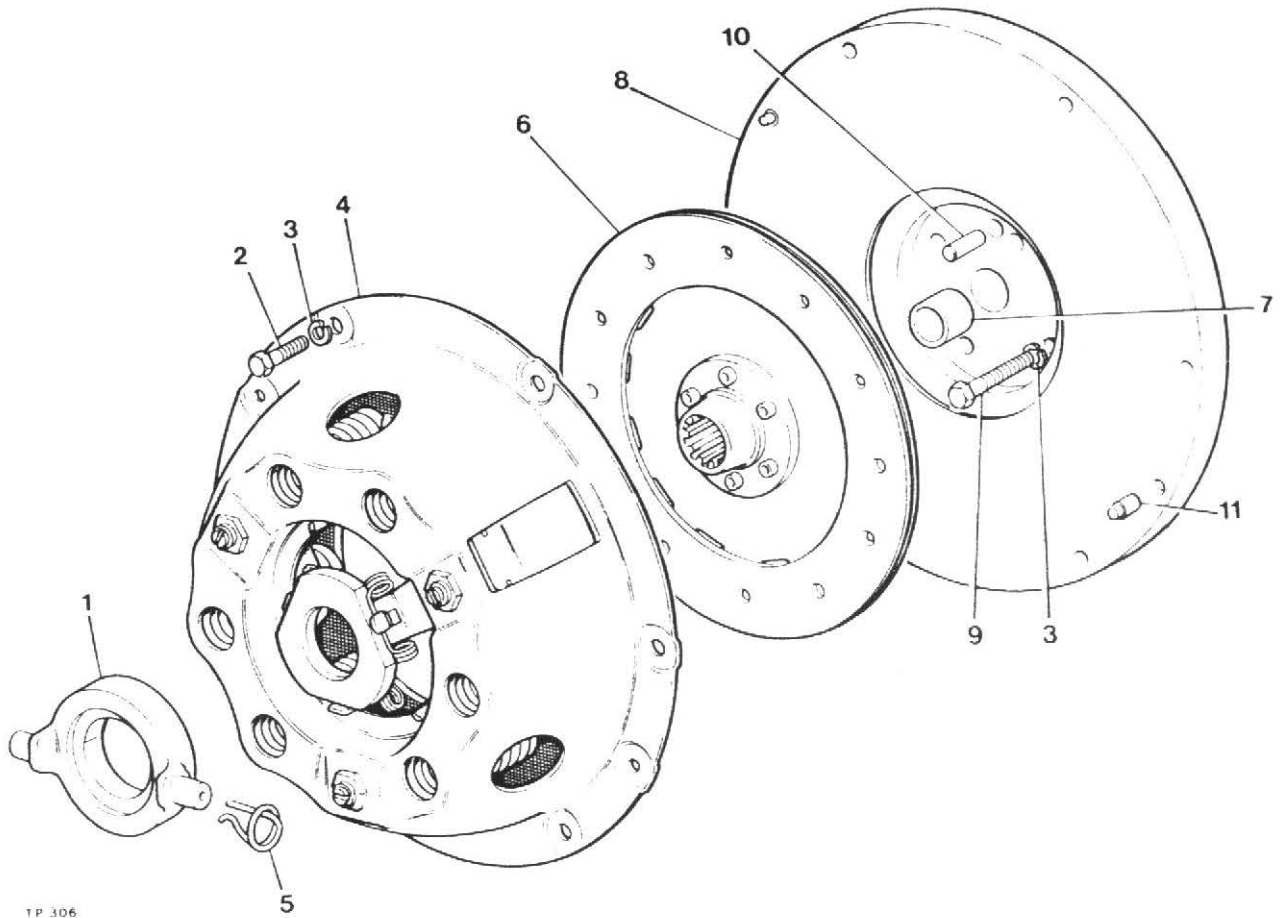

Item No.	Part No.	Description	Qty.
1	10579A01	Clutch Release Bearing	1
2	28S02D	Screw Set	6
3	41S04	Washer Spring	10
4	10597A01	Cover Assembly	1
5	10579A0101	Retainer Spring	2
6	10598A02	Drive Plate	1
7	10580A0101	Bush	1
8	10580A02	Flywheel Assembly (comprises of items 7, 8, & 11)	1
9	1S02C	Bolt, Petter PH Engine (drill for locking wire)	4
9A	6S02B	Bolt, Lister Engine (drill for locking wire)	4
10	C321	Dowel	1
11	10580A0102	Dowel	2
	10948A02	Clutch Kit (comprises of items 1, 4, 5 & 6)	1

It is recommended that instead of drilling the head of the bolts (item 9) for locking wire that one of each of tabwashers part no's 10531A02 and 10531A03 are used to prevent the bolts working loose.

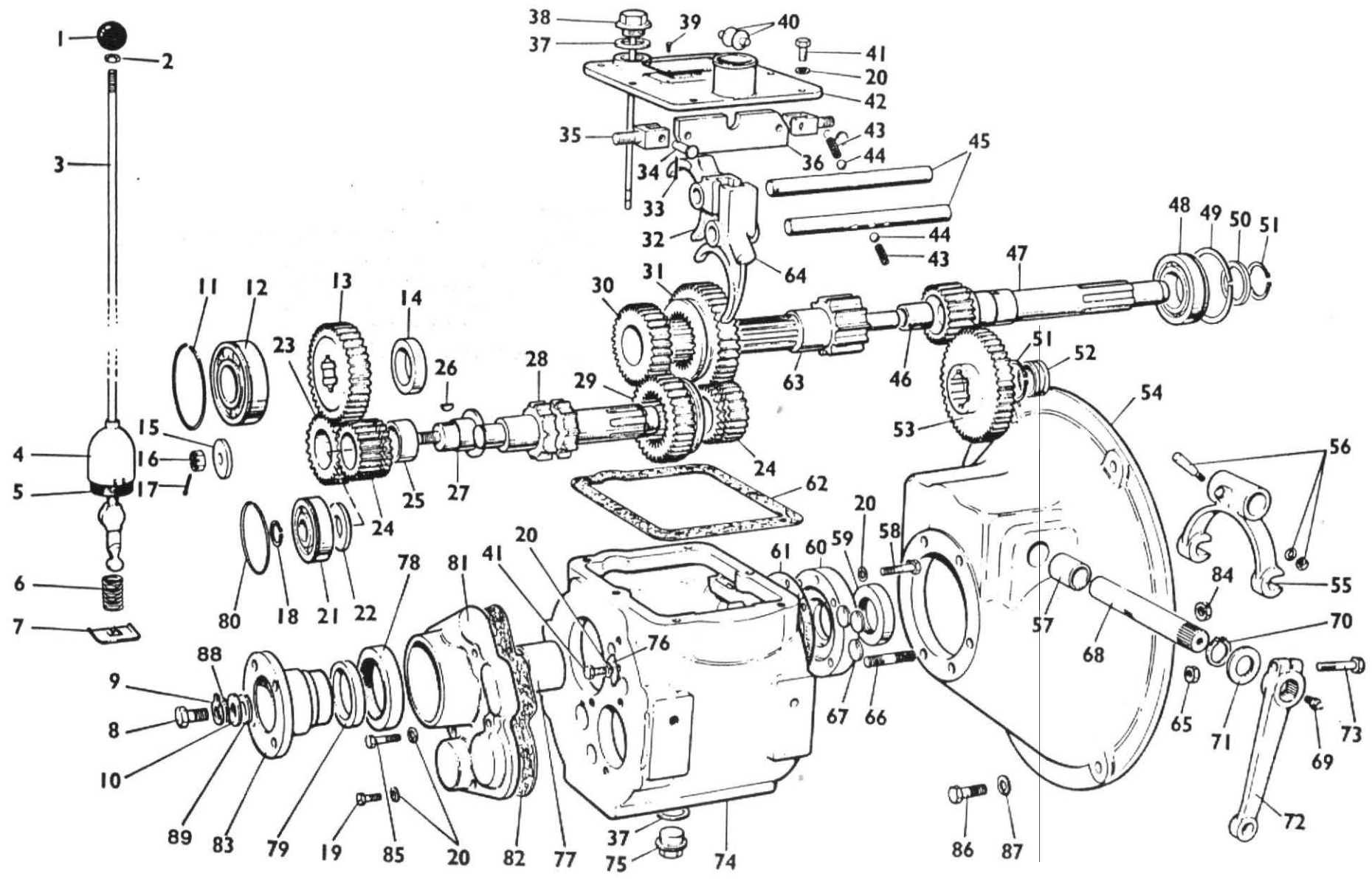

GEARBOX

Item No.	Part No.	Description	Qty.
	30101.A03	Gearbox complete	1
1	30101.A0201	Gear Lever Knob	1
2	2S.4	Gear Lever Locknut	1
3	20097.A03	Gear Lever	1
4	30101.A0203	Gear Lever Cap	1
5	30101.A0204	Gear Lever Cover	1
6	30101.A0205	Gear Lever Spring	1
7	30101.A0206	Gear Lever Retaining Plate	1
8	28S.5E	Bolt	1
9	30101.A0207	Tab Washer	1
10	30101.A0208	Washer	1
11	30101.A0209	Snap Ring	1
12	30101.A0210	Bearing, Mainshaft Rear	1
13	30101.A0211	Output Gear	1
14	30101.A0212	Output Gear Spacer	1
15	30101.A0213	Reverse Pinion Shaft Washer	1
16	30101.A0214	Reverse Spindle Nut	1
17	44S.2C	Split Pin	1
18	30101.A0215	Circlip	1
19	28S.1D	Bolt	3
20	13S.2	Spring Washer	17
21	30101.A0216	Layshaft Bearing	1
22	30101.A0217	Bearing Spacer	1
23	30101.A0218	Reverse Pinion	2
24	30101.A0219	Reverse Speed Gear	2
25	30101.A0220	Reverse Pinion Bush	1
26	30101.A0221	Reverse Pinion Shaft Key	1
27	30101.A0222	Reverse Pinion Shaft	1
28	30101.A0223	Layshaft	1
29	30101.A0224	2nd. Speed Sliding Gear	1
30	30101.A0225	Second Speed Gear	1
31	30101.A0226	1st Speed Gear	1
32	30101.A0227	2nd. and 3rd. Selector Fork	1
33	44S.1C	Split Pin, Interlock	2
34	30101.A0228	Clevis Pin, Interlock	2
35	30101.A0229	Stud, Interlock	2
36	30101.A0230	Interlock Plate	1
37	30101.A0231	Sealing Washer	2
38	30101.A0232	Dipstick	1
39	30101.A0233	Drive Screw	4
40	30101.A0234	Gear Lever Pad	2
41	28S.1C	Bolt	7
42	30101.A0235	Top Cover	1
43	30097.A0185	Detent Spring	2
44	30101.A0236	Detent Ball	2
45	30101.A0237	Selector Shaft	2
46	30101.A0238	Bearing, Primary Shaft	1
47	30101.A0239	Primary Shaft	1
48	30101.A0240	Input Bearing	1
49	30101.A0241	Snap Ring	1
50	30101.A0242	Bearing Spacer	1
51	30101.A0243	Circlip	2
52	30101.A0244	Layshaft Bush	1
53	30101.A0245	1st. Reduction Gear	1

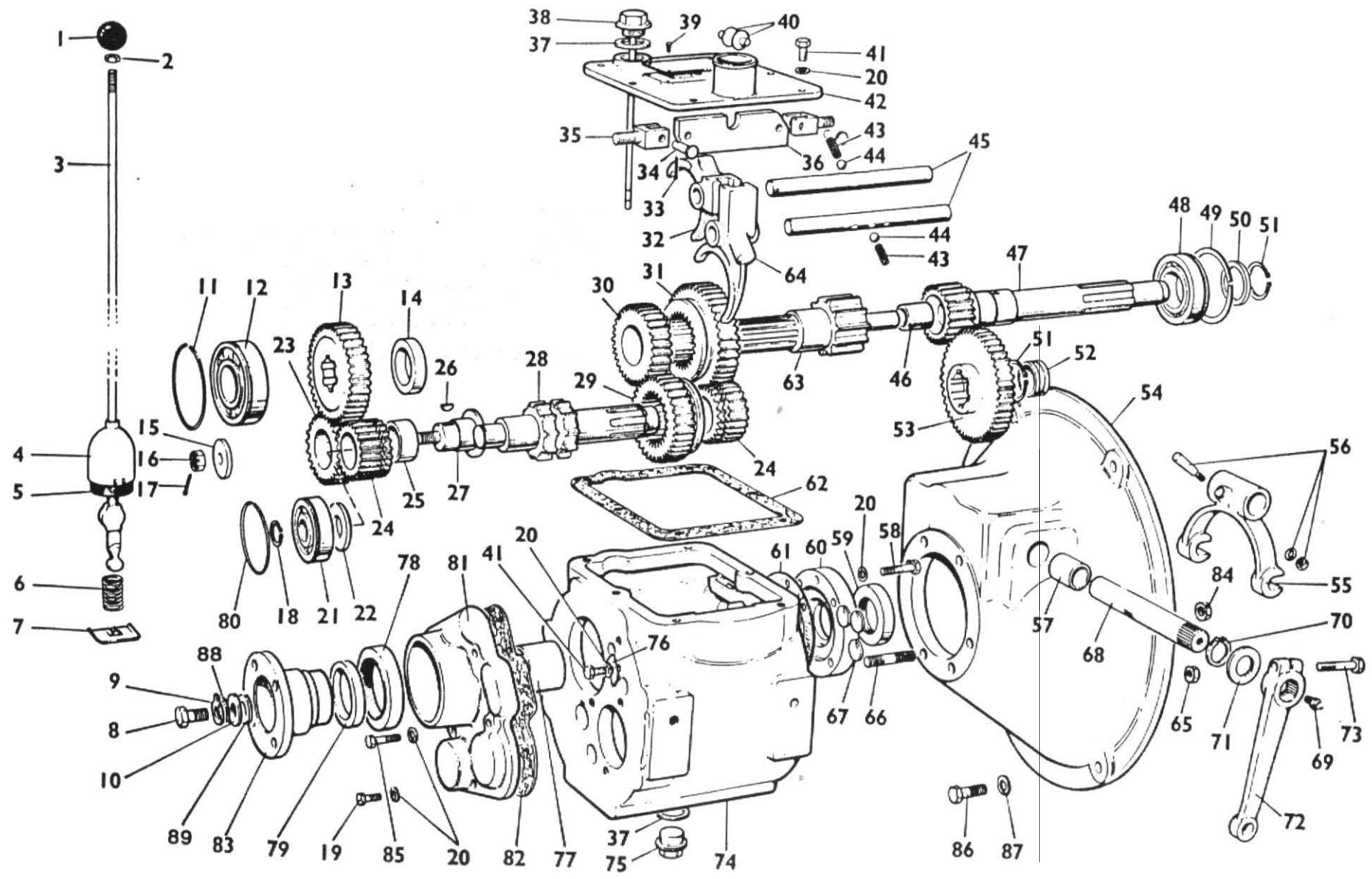

GEARBOX (Cont'd)

Item No.	Part No.	Description	Qty.
54	30101.A0246	Clutch Housing	1
55	30097.A0110	Clutch Release Fork	1
56	30097.A0111	Cotter, Nut and Washer S/A	1
57	30097.A0114	Cross Shaft Bush	2
58	6S.1A	Front Cover Bolt	4
59	30101.A0247	Oil Seal, Input	1
60	30101.A0248	Front Cover	1
61	30101.A0249	Front Cover Gasket	1
62	30101.A0250	Top Cover Gasket	1
63	30101.A0251	Mainshaft	1
64	30101.A0252	1st. and Reverse Selector Fork	1
65	9S.1	Clutch Lever Nut	1
66	30101.A0253	Clutch Housing Stud	6
67	30101.A0254	Welch Plug	3
68	30101.A0255	Clutch Cross Shaft	1
69	131S.1	Grease Nipple	2
70	30101.A0256	Circlip	1
71	30097.A0133	Cross Shaft Washer	1
72	30097.A0109	Clutch Release Lever	1
73	6S.1C	Clutch Lever Bolt.....	1
74	30101.A0258	Gearcase	1
75	30097.A0163	Drain Plug	1
76	30101.A0259	Selector Locking Strip	1
77	30101.A0260	Spacer	1
78	30097.A0132	Rear Oil Seal	1
79	30101.A0265	Dust Shield	1
80	30101.A0261	Snap Ring	1
81	30101.A0262	Output Cover	1
82	30101.A0263	Output Cover Gasket	1
83	30101.A0264	Coupling	1
84	107S.3	Nut (Clutch Housing)	6
85	6S.1	Bolt	2
86	1S.3B	Bolt 3/8" BSF x 1" Long	6
87	41S.5	Spring Washer 3/8" dia.	6
88	30143.A0111	Fibre Washer	1
89	30143.A0101	Fibre Washer	1

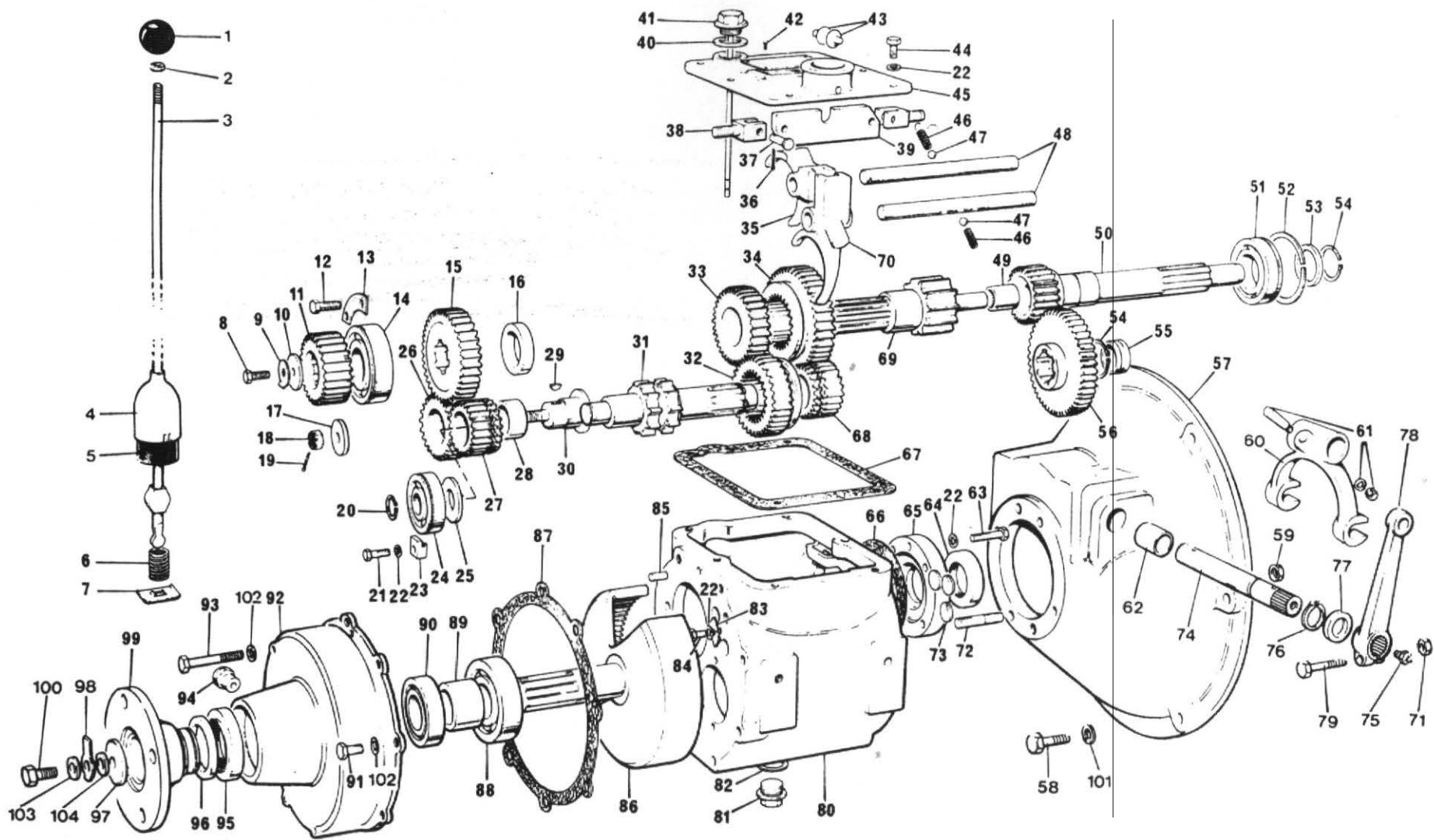

GEARBOX

Item No.	Part No.	Description	Qty.
	30190.A02	Gearbox complete	1
1	30101.A0201	Knob, Gear Lever	1
2	95S.3	Locknut, Gear Lever 3/8" UNF Half Nut	1
3	20097.A03	Gear Lever	1
4	30101.A0203	Cap, Gear Lever	1
5	30101.A0204	Cover, Gear Lever	1
6	30101.A0205	Spring, Gear Lever	1
7	30101.A0206	Retaining Plate, Gear Lever	1
8	28S.3E	Screw, Mainshaft 3/8" UNF x 1" Long	1
9	30190.A0101	Lockwasher - Tab	1
10	30190.A0102	Washer, Reduction Pinion	1
11	30190.A0103	Reduction Pinion	1
12	28S.1B	Screw Bearing Retainer 1/4" UNF x 1/2" Long	2
13	30190.A0104	Bearing Retainer, Small	1
14	30101.A0210	Bearing, Mainshaft Rear	1
15	30101.A0211	Output Gear	1
16	30101.A0212	Spacer, Output Gear	1
17	30101.A0213	Washer, Reverse Pinion Shaft	1
18	102S.4	Nut, Reverse Spindle 7/16" UNF Castle	1
19	44S.2C	Split Pin 3/32" Dia., x 1" Long	1
20	30101.A0215	Circlip	1
21	28S.1D	Screw 1/2" UNF x 3/4" Long	2
22	67S.1	Shakeproof Washer 1/2" Dia.....	12
23	30190.A0105	Clip Layshaft Bearing	2
24	30101.A0216	Layshaft Bearing	2
25	30101.A0217	Bearing Spacer	1
26	30101.A0218	Reverse Pinion	1
27	30101.A0219	Reverse Speed Gear	2
28	30101.A0220	Bush, Reverse Pinion	1
29	30101.A0221	Key Reverse Pinion Shaft	1
30	30101.A0222	Shaft, Reverse Pinion	1
31	30101.A0223	Layshaft	1
32	30101.A0224	2nd Speed Sliding Gear	1
33	30101.A0225	Second Speed Gear	1
34	30101.A0226	1st Speed Gear	1
35	30101.A0227	Selector Fork, 2nd & 3rd.....	1
36	44S.1C	Split Pin Interlock 1/16" dia., x 1" Long	2
37	30101.A0228	Celvis Pin, Interlock	2
38	30101.A0229	Stud, Interlock	2
39	30101.A0230	Interlock Plate	1
40	42S.5	Seal, Dipstick	1
41	30101.A0232	Dipstick	1
42	30101.A0233	Drive Screw	4
43	30101.A0234	Pad, Gear Lever	2
44	28S.1C	Screw, Top Cover 1/2" UNF x 5/8" Long	6
45	30101.A0235	Top Cover	1
46	30097.A0185	Detent Spring	2
47	30101.A0236	Detent Ball	2
48	30101.A0237	Selector Shaft	2
49	30101.A0238	Bearing, Primary Shaft	1
50	30101.A0239	Primary Shaft	1
51	30101.A0240	Input Bearing	1
52	30101.A0241	Snap Ring	1
53	30101.A0242	Bearing Spacer	1
54	30101.A0243	Circlip	2
55	30101.A0244	Bush, Layshaft	1
56	30101.A0245	1st Reduction Gear	1

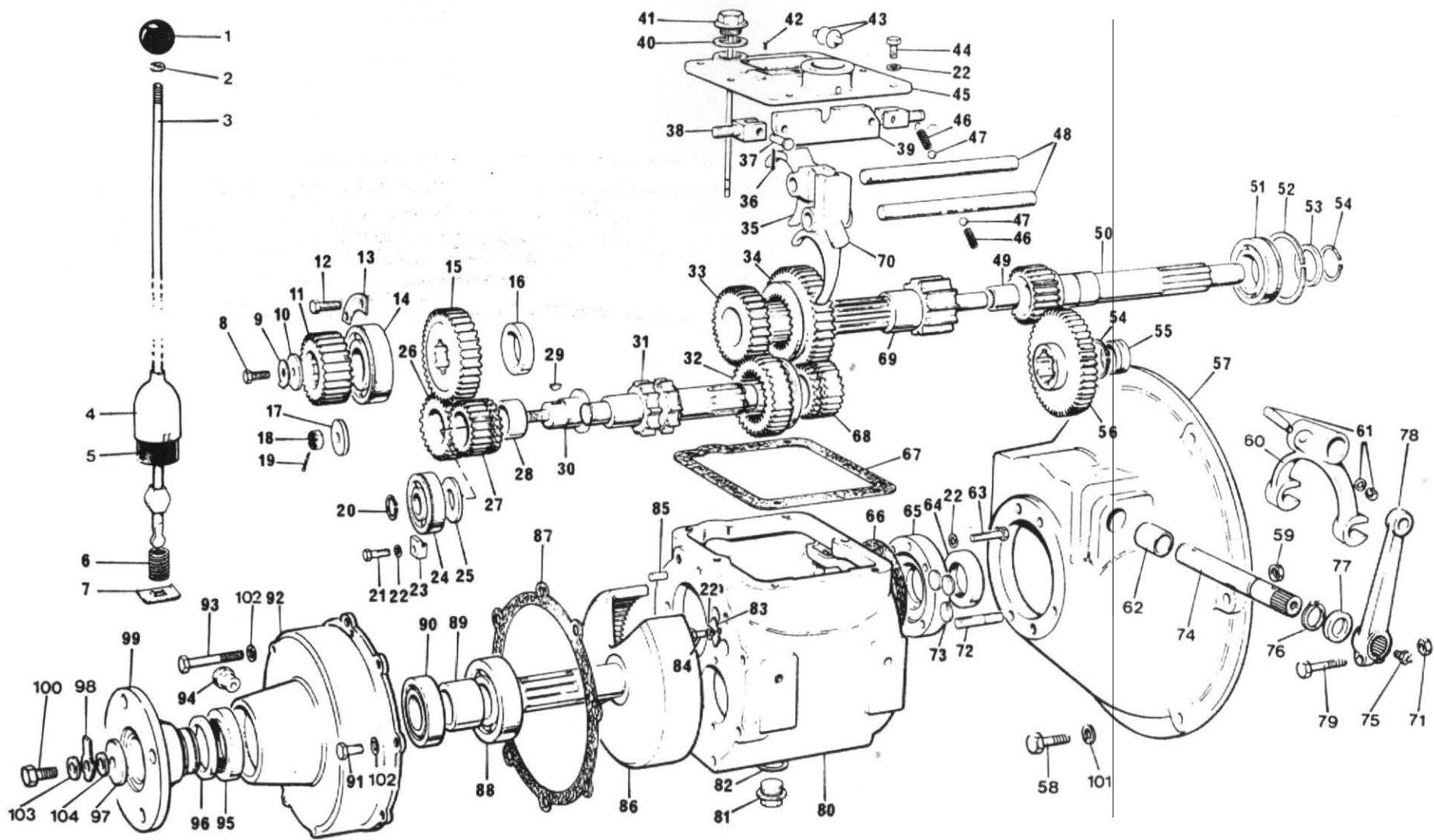

GEARBOX (Cont'd)

Item No.	Part No.	Description	Qty.
57	30101.A0246	Clutch Housing	1
58	3S.3E	Setscrew-Clutch Housing 3/8" BSF x 1" Long(Petter)	6
	69S.3E	Setscrew-Clutch Housing 3/8" UNC x 1" Long(Lister)	6
59	30190.A0116	Nut Nyloc 3/8" UNF	6
60	30097.A0110	Clutch Release Fork	1
61	30097.A0111	Cotter, Nut and Washer S/A	1
62	30097.A0114	Bush, Cross Shaft	2
63	6S.1B	Bolt, Front Cover 1/2" UNF x 1 1/2" Long	4
64	30101.A0247	Oil Seal, Input	1
65	30101.A0248	Front Cover	1
66	30101.A0249	Joint, Front Cover	1
67	30101.A0250	Joint, Top Cover	1
68	30101.A0219	Reverse Speed Gear	2
69	30190.A0106	Mainshaft	1
70	30101.A0252	Selector Fork, 1st and Reverse	1
71	9S.1	Nut Clutch Lever 1/2" UNF	1
72	30101.A0253	Stud, Clutch Housing	6
73	30101.A0254	Sealing Disc, Selector Shaft	3
74	30101.A0255	Clutch Cross Shaft	1
75	131S.6	Grease Nipple	2
76	30101.A0256	Circlip	1
77	30101.A0257	Washer, Cross Shaft	1
78	30097.A0109	Clutch Release Lever	1
79	6S.1C	Bolt, Clutch Lever 1/2" UNF x 1 1/2" Long	1
80	30190.A0107	Casing	1
81	30190.A0108	Drain Plug	1
82	42S.5	Seal, Drain Plug	1
83	30101.A0259	Selector Locking Strip	1
84	28S.1C	Setscrew 1/2" UNF x 5/8" Long	2
85	30097.A0155	Dowel	2
86	30190.A0110	Internal Gear	1
87	30190.A0112	Joint, Reduction Housing	1
88	30190.A0111	Bearing, Internal Gear Front	1
89	30101.A0260	Spacer	1
90	30190.A0113	Bearing, Internal Gear Rear	1
91	28S.2D	Hex. Hd. Screw 5/16" UNF x 3/4" Long	4
92	30190.A0114	Reduction Housing	1
93	6S.2J	Hex. Hd. Bolt 5/16" UNF x 2,3/4" Long	4
94	30097.A0171	Breather	1
95	30097.A0132	Oil Seal, Rear	1
96	30101.A0265	Dust Shield	1
97	30101.A0208	Washer, Coupling	1
98	30101.A0207	Lockwasher	1
99	30101.A0264	Coupling	1
100	28S.5E	Screw, Coupling 1/2" UNF x 1" Long	1
101	41S.5	Spring Washer 3/8"	6
102	41S.4	Spring Washer 5/16"	8
103	30143.A0111	Fibre Washer	1
104	30143.A0101	Fibre Washer	1

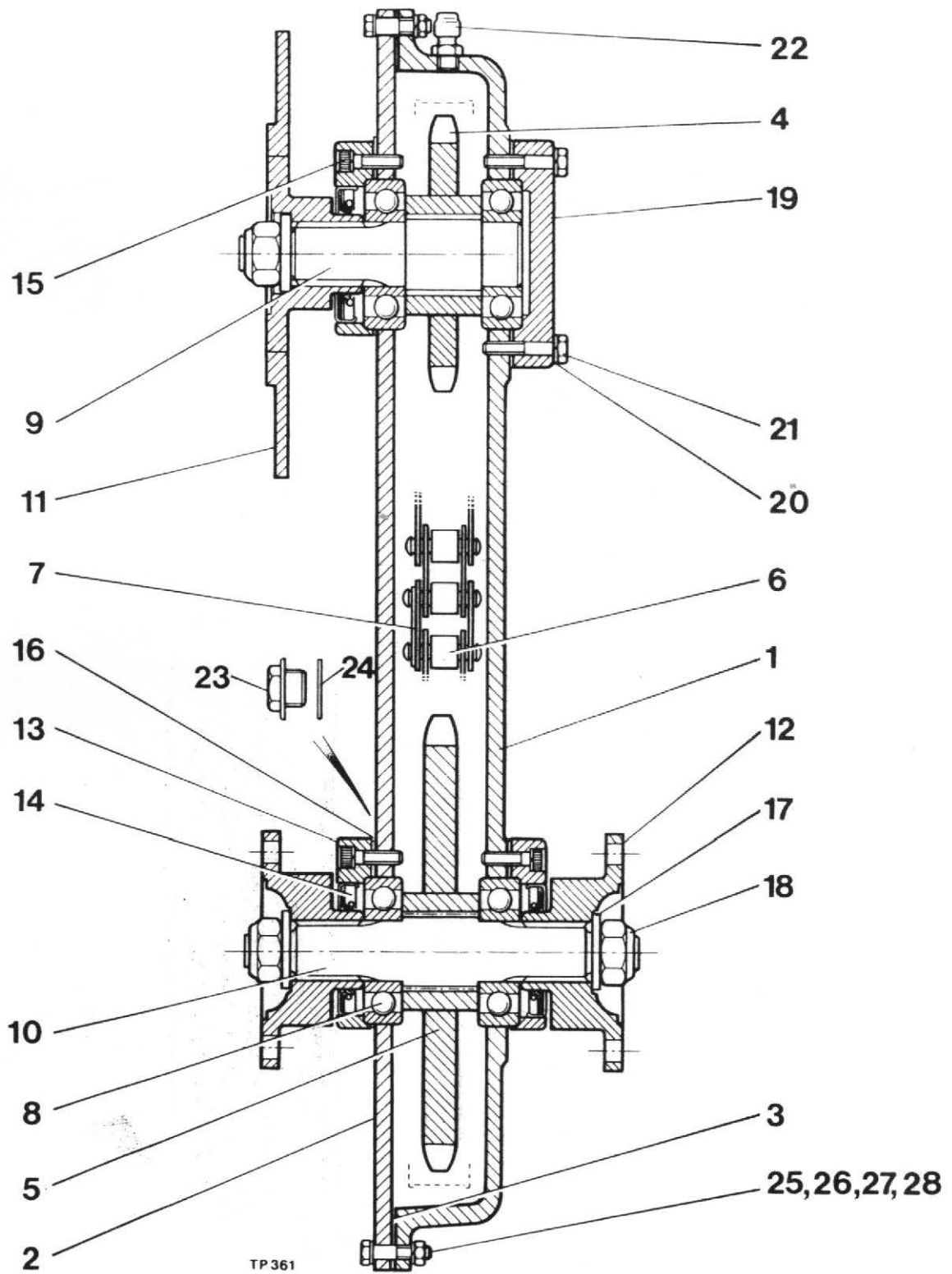

TRANSFER BOX

Item No.	Part No.	Description	Qty.
	40098.A01	Transfer Box complete (when fitted) 1" Pitch Chain	1
	40098.A02	Transfer Box complete (when fitted) 3/4" Pitch Chain	1
1	4-35-96	Case	1
2	40097.A01	Cover	1
3	4-35-20	Gasket	1
4	10294.A01	Chain Wheel 15T (when fitted) 1" Pitch Chain ...	1
	10294.A02	Chain Wheel 19T (when fitted) 3/4" Pitch Chain...	1
5	4-35-17	Chain Wheel 19T (when fitted) 1" Pitch Chain ...	1
	10294.A03	Chain Wheel 25T (when fitted) 3/4" Pitch Chain ..	1
6	4-35-353	Roller Chain (when fitted) 1" Pitch Chain ..	1
	80S.3	Roller Chain (when fitted) 3/4" Pitch Chain ..	1
7	81S.1	Connecting Link (when fitted) 1" Pitch Chain ..	1
	81S.2	Connecting Link (when fitted) 3/4" Pitch Chain ..	1
8	88S.6	Ball Bearing	4
9	10299.A01	Input Shaft	1
10	10300.A01	Output Shaft.....	1
11	20109.A01	Input Flange (c/w Brake Disc)	1
12	10384.A01	Output Flange	2
13	4/35-102	Oil Seal Housing	3
14	89S.1	Oil Seal	3
15	90S.2H	Capscrew	12
16	10293.A01	Gasket	4
17	10S.6	Washer 3/4" Dia.....	3
18	87S.8	Locknut 3/4" UNF	3
19	10298.A01	End Cover	1
20	10S.1	Washer 1/4" Dia.....	4
21	6S.1A	Hex. Hd. Bolt 1/4" UNF x 1,1/8" Long	1
22	10305.A01	Breather	1
23	10301.A01	Level/Filler Plug	1
24	42S.5	Fibre Washer	1
25	8S.2C	Hex. Hd. Bolt M6 x 35 Long	24
26	12S.2A	Washer M6	24
27	17S.3A	Spring Washer M6	24
28	7S.2A	Nut M6	24

PROP. SHAFTS

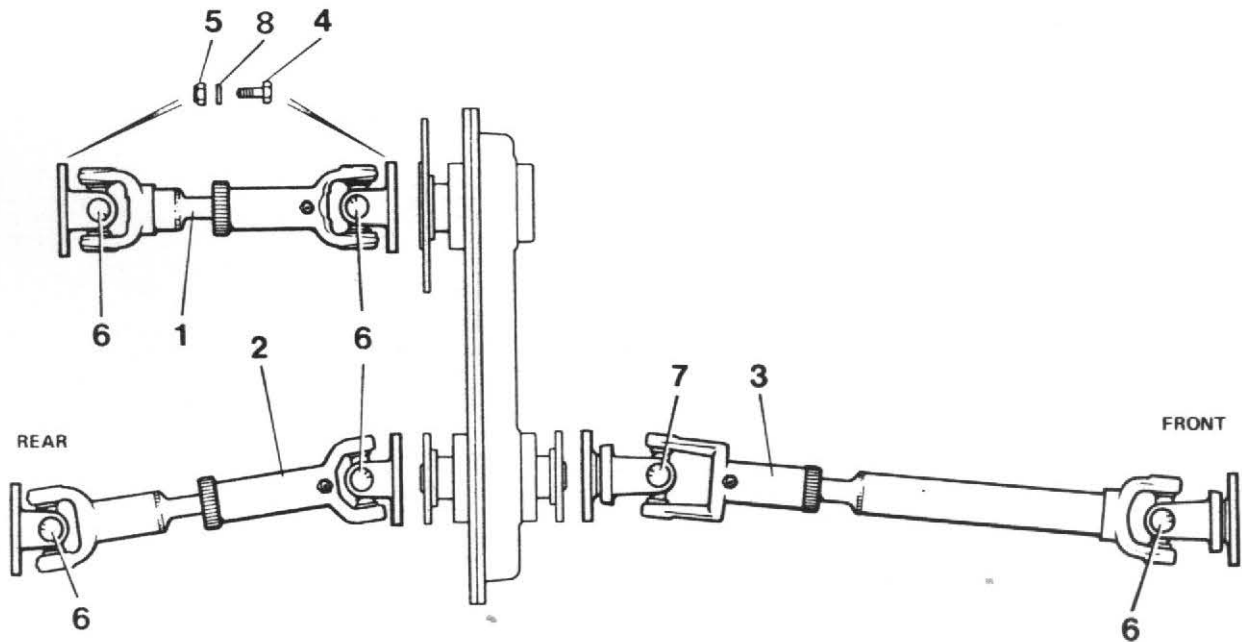

NEWAGE AXLE MACHINES

Item No.	Part No.	Description	Qty.
1	20087.A01	Prop Shaft	1
2	20088.A01	Prop Shaft	1
3	30095.A01	Prop Shaft	1
4	10365.A02	Prop Shaft Bolt	24
5	132S.3	Nut 3/8" UNF	24
6	10568.A01	Repair Kit (Std. Angle)	A/R
7	10568.A02	Repair Kit (Wide Angle)	A/R
8	41S.05	Washer - Spring 3/8" I.D. (Use under Bolt head)	24

SALISBURY AXLE MACHINES

Item No.	Part No.	Description	Qty.
1	20086.A01	Prop Shaft, Gearbox to Transfer Box	1
2	20089.A01	Prop Shaft, Transfer Box to Rear Axle	1
3	30096.A01	Prop Shaft, Transfer Box to Front Axle	1
4	10365.A02	Prop Shaft Bolt	24
5	132S.3	Nut 3/8" UNF	24
6	10568.A01	Repair Kit (Std. Angle)	A/R
7	10568.A02	Repair Kit (Wide Angle)	A/R
8	41S.05	Washer - Spring 3/8" I.D. (Use under Bolt head).	24

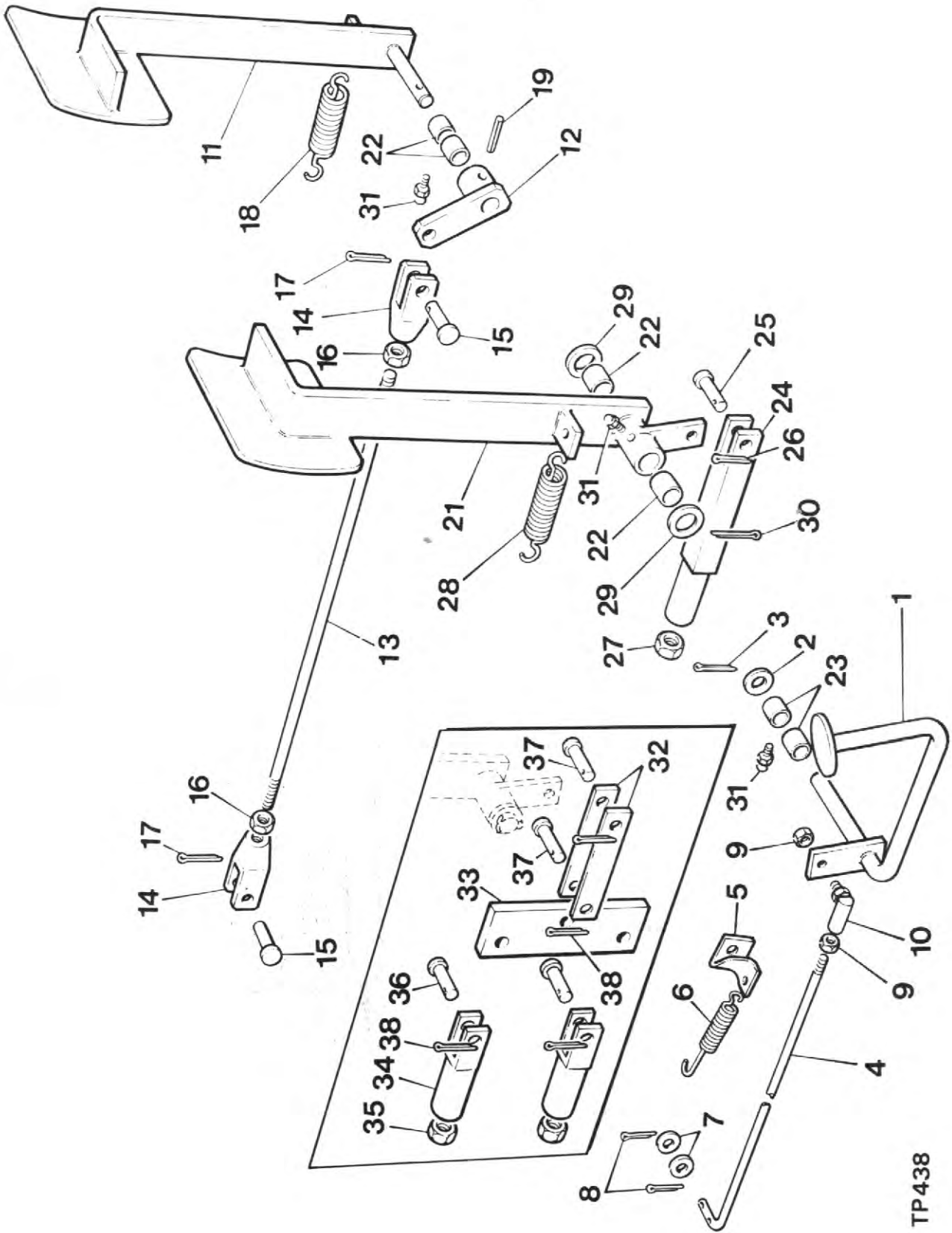

TP438

PEDAL CONTROLS

Item No.	Part No.	Description	Qty.
1	20231.A02	Pedal - Accelerator	1
2	10S.04	Washer - Flat - ½" I.D.	1
3	44S.02	Pin - Split - 3/32" Dia. x 1"	1
4	20166.A0201	Rod - Accelerator - ½" Dia. x 751mm (Petter)	1
	10362.A04	Rod - Accelerator (Lister)	1
5	C163	Bracket	1
6	C173D	Spring - Return	1
7	10S.01	Washer - Flat ½" I.D.	2
8	44S.01	Pin - Split - 1/16" Dia. x 1"	2
9	74S.02	Nut - Half - Hex. 1/4" BSF	2
10	C160B	Rod - Ball End	1
11	20096.A05	Pedal - Clutch	1
12	10563.A02	Lever - Clutch	1
13	38S.C50	Rod - Clutch	1
14	C174A	Clevis	2
15	10650.A17	Pin - Clevis	2
16	74S.04	Nut - Half 3/8" BSF	2
17	44S.02C	Pin - Split 3/32" Dia. x 1"	2
18	C173B	Spring	1
19	54S.07M	Pin - Tension 8mm Dia. x 40 Long	1
21	20232.A01	Pedal - Brake	1
22	43S.02	Bush - Bearing 3/4" I.D.	4
23	43S.03	Bush - Bearing 1/2" I.D.	2
24	10454.A01	Clevis - Extended	1
25	10650.A18	Pin - Clevis 3/8" Dia.	1
26	44S.02C	Pin - Split 3/32" x 1"	1
27	95S.03	Nut - Half-Hex. 3/8" UNF	1
28	C173B	Spring - Return	1
29	10S.17	Washer - Plain	2
30	44S.04	Pin - Split	1
31	131S.3	Nipple - Grease	3

Alternative Brake Linkage for use with Twin Master Cylinders

32	10436.A02	Links - Pedal	2
33	20117.A06	Beam - Compensator	1
34	10454.A02	Clevis - Extended	2
35	95S.03	Nut - Half- Hex. 3/8" UNF	2
36	10650.A17	Pin - Clevis 3/8" Dia.	2
37	10650.A18	Pin - Clevis 3/8" Dia.	2
38	44S.02C	Pin - Split 3/32" Dia. x 1"	4

VALVE CONTROL, HANDBRAKE AND ENGINE STOP

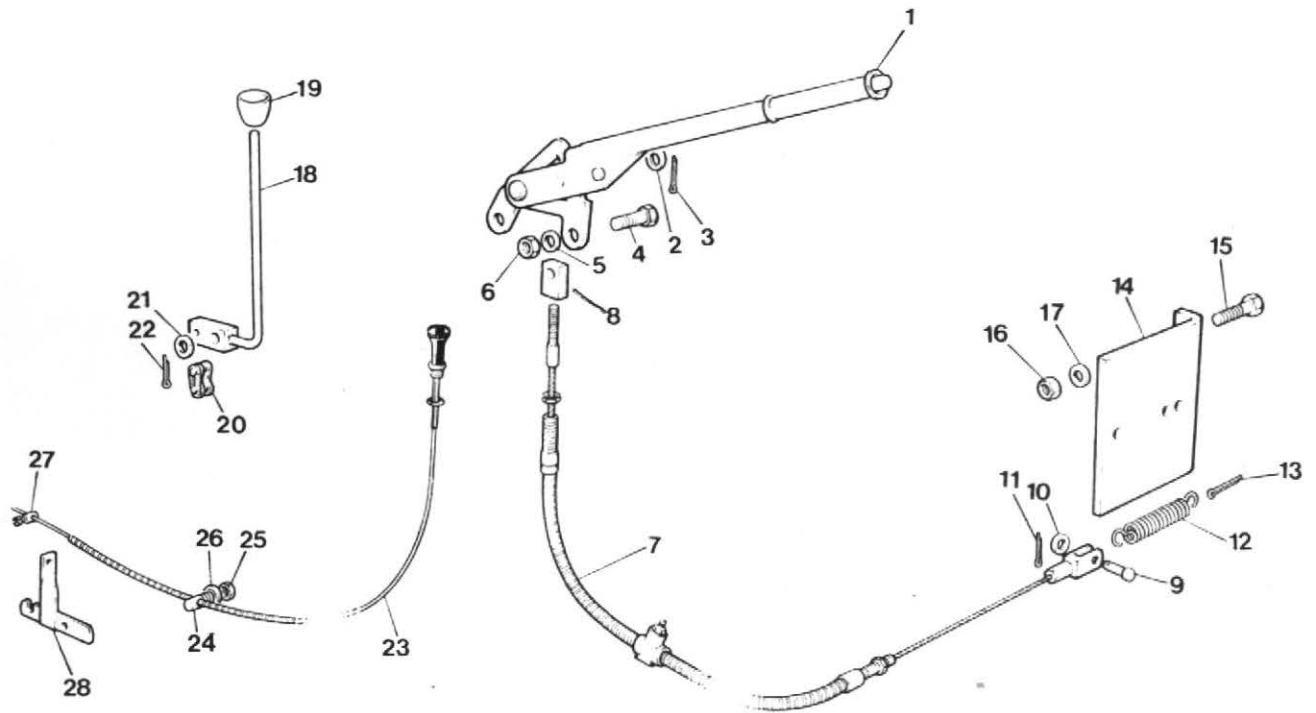

TP436

Item No.	Part No.	Description	Qty.
1	20208.A01	Lever - Handbrake	1
2	10S.14	Washer - 10 I.D.	1
3	44S.01C	Pin - Split 1/16" Dia. x 1"	1
4	11S.04C	Bolt - Hex. Hd. M10 x 25	2
5	7S.04	Nut - M10	2
6	17S.04	Washer - Spring 10 I.D.	2
7	10367.A03	Cable - Handbrake	1
8	L309	Block - Cable End	1
9	10650.A13	Pin - Clevis	1
10	10S.01	Washer - Plain 1/4" I.D.	1
11	44S.01C	Pin - Split 1/16" x 1" Long	1
12	C173D	Spring - Return	1
13	44S.05E	Pin - Split 3/16" x 1 1/2" (Return Spring)	1
14	20191.A01	Bracket - Brake Caliper	1
15	11S.04C	Bolt - Hex. Hd. M10 x 25	2
16	7S.04	Nut - M10	2
17	12S.05	Washer - Plain	2
18	10520.A03	Lever - Hyd. Control Valve	1
19	10211.A01	Knob - Control Lever	1
20	4-60-178	Link - Connecting	1
21	10S.14	Washer - Plain 3/8" I.D.	1
22	44S.02	Pin - Split	1
23	4-60-239	Cable - Engine Stop	1
24	4-60-242	Screw - Clamp	1
25	9S.03	Nut - 3/8" UNF	1
26	67S.04	Washer - Shakeproof - Internal	1
27	4-35-196	Nipple - Solderless	1
28	10346.A01	Control - Engine Stop (Lister only)	1

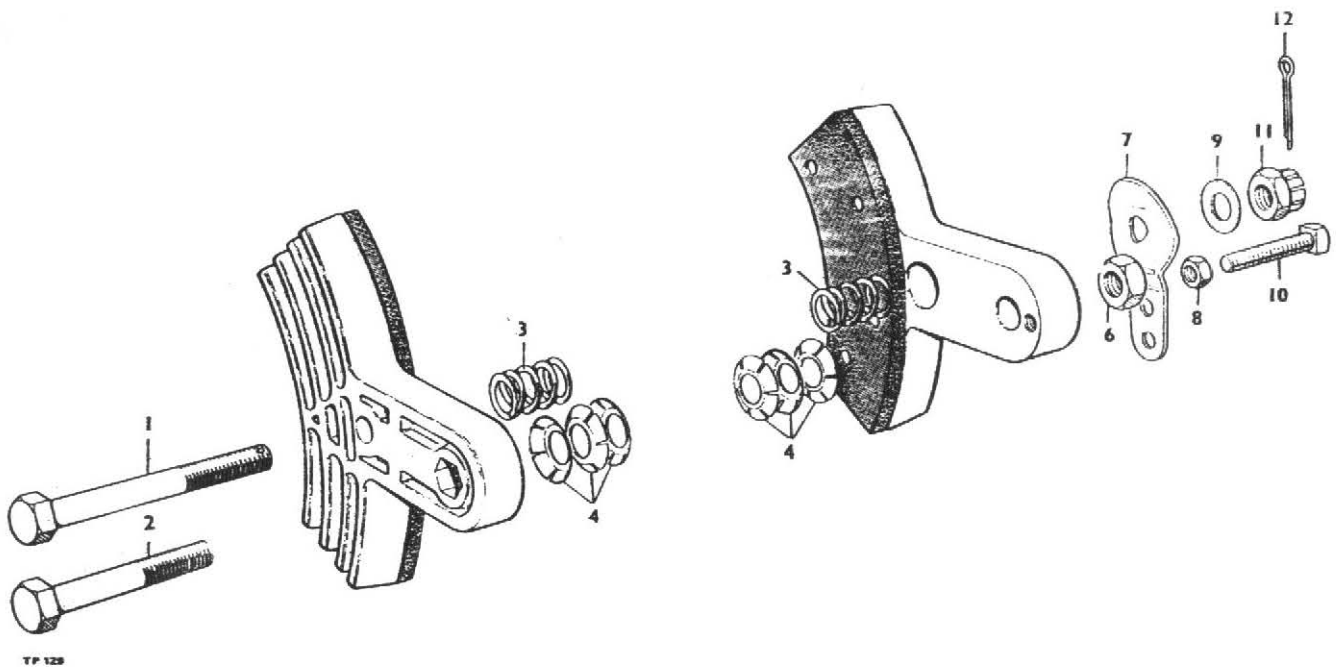

CALIPER, parking brake

Item	Part no	Description	Qty
1A	10578A01	CALIPER, one pair, assembly	1
1	28S02T	SCREW	1
2	28S02P	SCREW	1
3	10578A0101	SPRING, centring	2
4	10578A0102	WASHER, tension	6
6	9S02	NUT	1
7	10578A0104	CAM	1
8	230S01	NUT, locking	1
9	10578A0105	WASHER	1
10	66S01H	SCREW, set	1
11	227S02	NUT, castle	1
12	44S01C	PIN, cotter	1
13	1072A4	PAD c/w rivets	2

BRAKE CALIPER ASSEMBLY

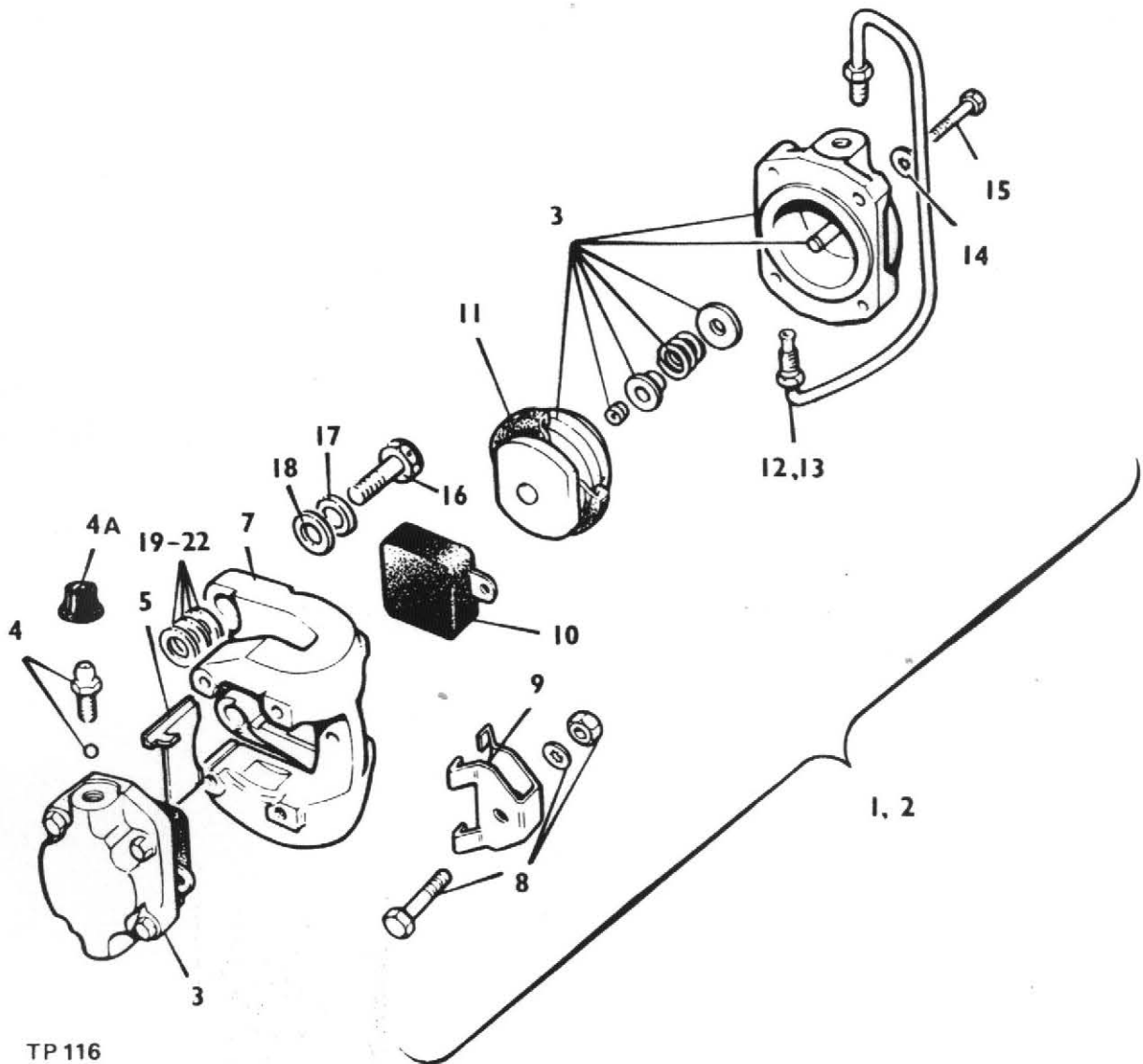

TP 116

Item No.	Pt. No.	Description	Qty.
1	20168.A01	Caliper Complete (R.H.)	1
2	20168.A02	Caliper Complete (L.H.)	1
3	20168.A0101	Piston and Cylinder Assembly	2
4	20168.A0102	Bleed Screw and Ball Assembly	1
4A	20168.A0103	Dust Cover (Bleedscrew)	1
5	20168.A0104	Plate, Support	1
6	20168.A0201	Body, Caliper (L.H.)	1
7	20168.A0105	Body, Caliper (R.H.)	1
8	20168.A0106	Nut, Bolt and Washer (Keep Plate)	1
9	20168.A0107	Keep Plate	1
10	20168.A0108	Friction Pad Complete (Set of 4)	1 Set
11	20168.A0109	Seal Kit (Dust and Piston)	2
12	20168.A0202	Bridge Pipe (L.H.)	1
13	20168.A0110	Bridge Pipe (R.H.)	1
14	20168.A0111	Washer, Shakeproof	8
15	20168.A0112	Bolt, Retaining (Cylinder)	8
16	20168.A0113	Caliper Mounting Bolt	4
17	20168.A0114	Washer	4
18	20168.A0115	Washer	4
19	20168.A0116	Shim .003"	A/R
20	20168.A0117	Shim .005"	A/R
21	20168.A0118	Shim .010"	A/R
22	20168.A0119	Shim .030"	A/R

BRAKE MASTER CYLINDER

(OIL IMMERSED BRAKES)

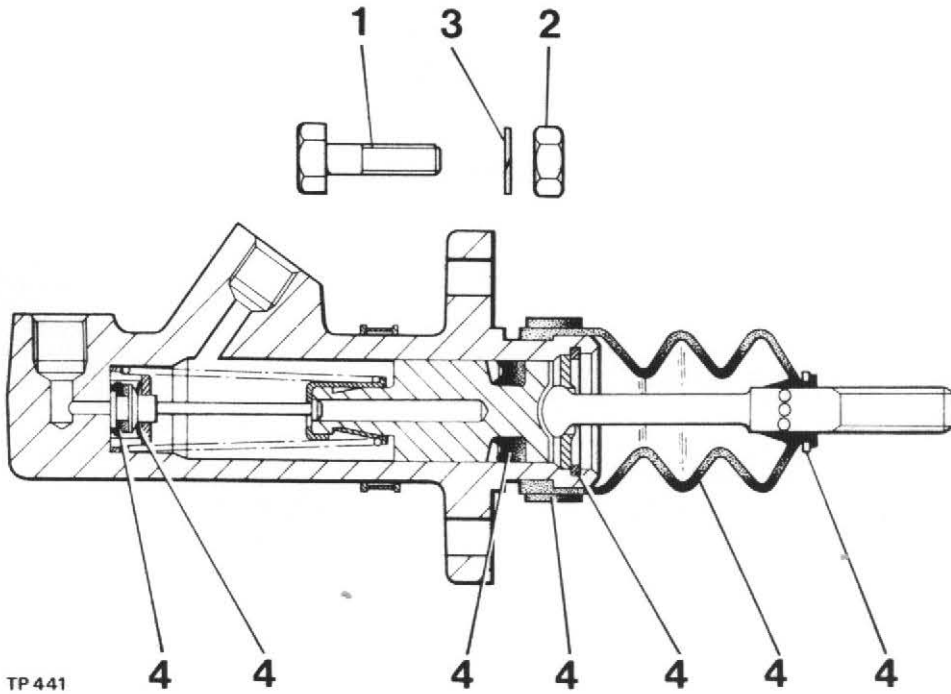

Item No.	Part No.	Description	Qty.
	20102.A02	Master Cylinder	2
1	8S.3B	Bolts Hex. Hd. M8 x 30 Long	4
2	61S.3	Nuts M8	4
3	12S.3	Plain Washer	4
4	10570.A01	Service Kit	A/R

BRAKE MASTER CYLINDER
(CALIPER DISC BRAKES)

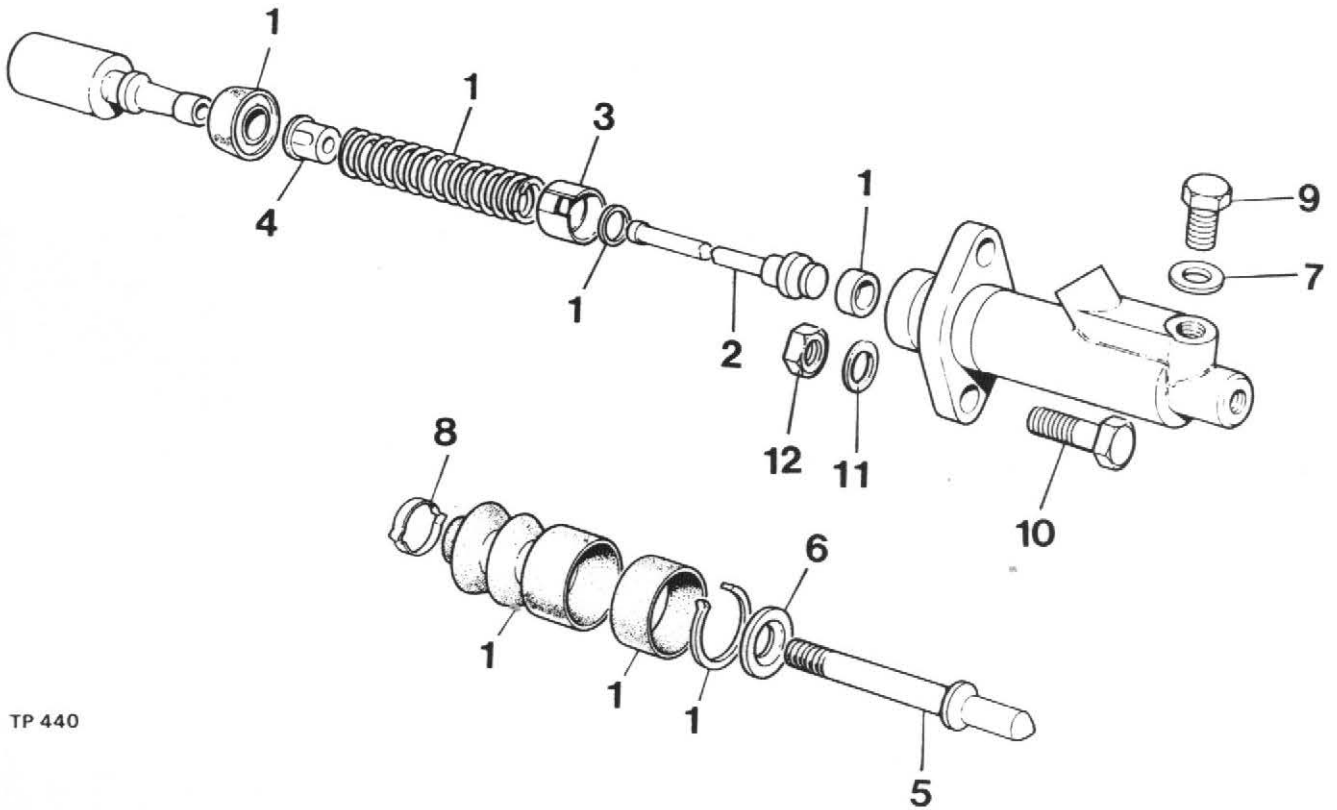

TP 440

Item No.	Part No.	Description	Qty.
	20102.A03	Master Cylinder (complete)	1
1	20102.A0301	Seal Kit	1
2	20102.A0302	Valve Stem	1
3	20102.A0303	Valve Spacer	1
4	20102.A0304	Valve Spring Retainer	1
5	20102.A0305	Push Rod	1
6	20102.A0306	Retaining Washer	1
7	20102.A0307	Washer	1
8	20102.A0309	Dust Cover Retainer	1
9	20102.A0311	Plug	1
10	11S.3E	Bolt M8 x 35mm Long	2
11	17S.4	Spring Washer.....	2
12	7S.3	Nut M8	2

BRAKE PIPES AND FITTINGS

NEWAGE AXLES (OIL IMMERSED BRAKES)

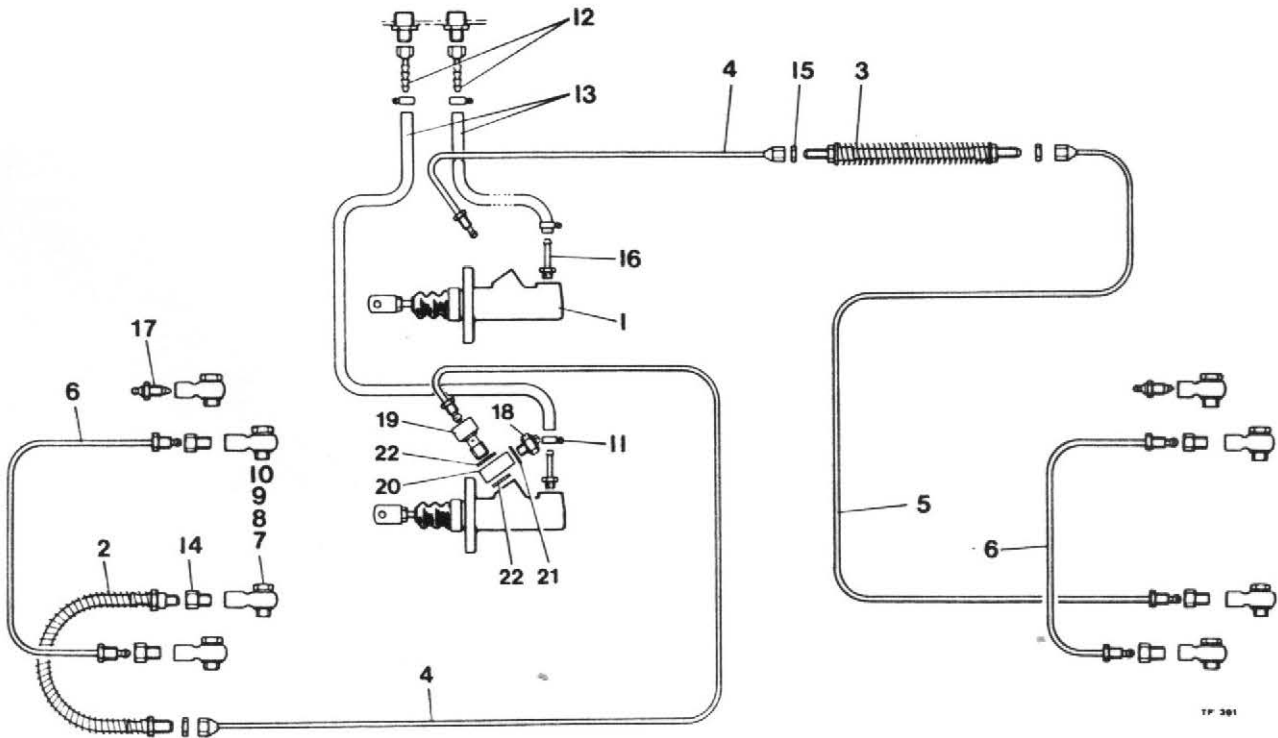

TF 381

Item No.	Part No.	Description	Qty.
1	20102.A02	Master Cylinder	2
2	10516.A02	Flexible Brake Hose	1
3	10517.A02	Flexible Brake Hose	1
4	10577.A0101	Brake Pipe M12 x 770 Long Male/Female	2
5	10577.A0102	Brake Pipe M12 x 965 Long Male/Female	1
6	10577.A0202	Brake Pipe M12 x 345 Long Male/Female	2
7	64474287	Banjo	8
8	376102W	Banjo Bolt	8
9	378700	Washer	8
10	378703	Washer	8
11	97S.1	Pipe Clip	4
12	110S.1A	Nozzle 1/4" BSP	2
13	29S.7	Hose 1/4" Bore x 1000mm Long	2
14	10354.A02	Brake Pipe Adaptor	6
15	10582A01	Half Nut M12	3
16	10542.A01	Stub Pipe Assembly	2
17	30082.A0215	Brake Bleed Valve (see also Axle section)	2
18	10744.A01	Brake Switch (if fitted)	1
19	10656.A01	Special Bolt (if fitted)	1
20	10387.A01	Connector (if fitted)	1
21	3787 03	Washer (if fitted)	1
22	10661.A01	Washer (if fitted)	2

BRAKE PIPES AND FITTINGS
SALISBURY AXLES (OIL IMMERSED BRAKES)

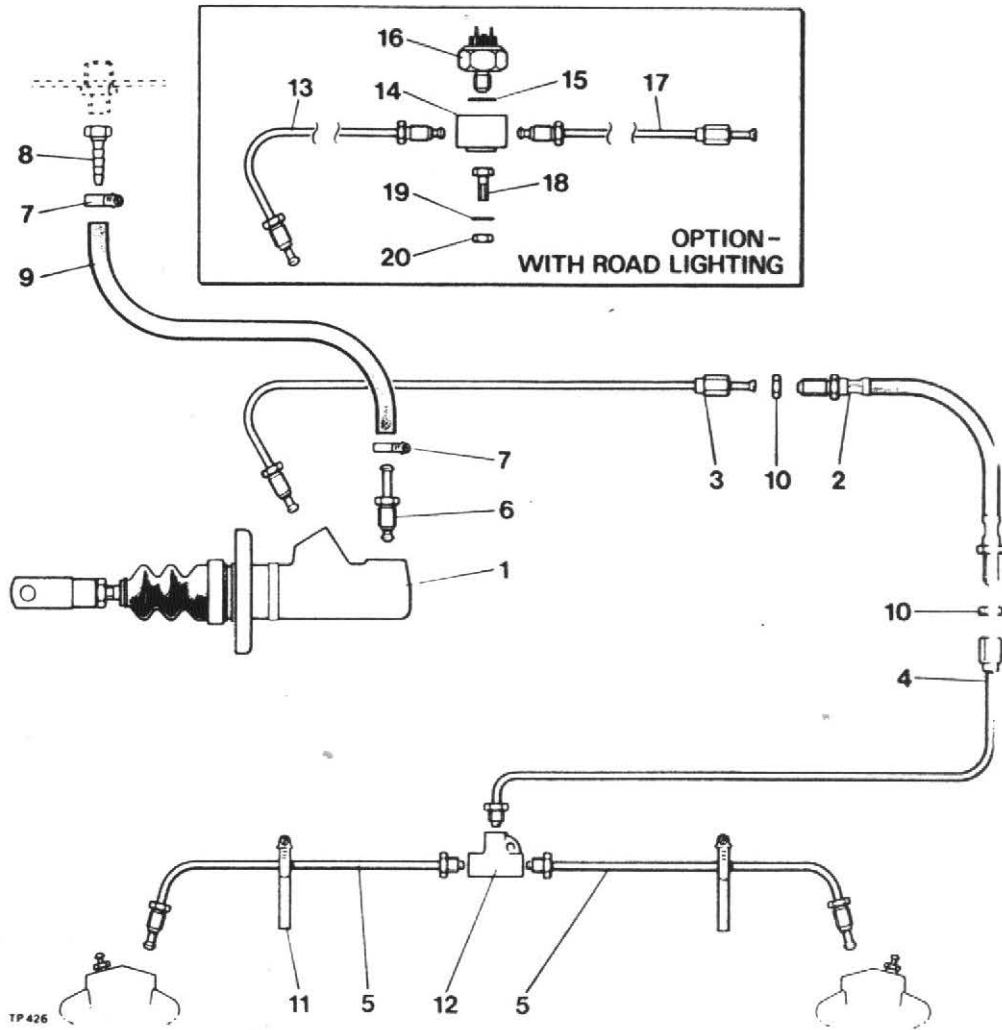

Item No.	Part No.	Description	Qty.
1	20102.A02	Master Cylinder	1
2	10517.A02	Flexible Hose	1
3	10577.A0101	Pipe M12 x 770mm Long Male/Female	1
4	10577.A0110	Pipe M12 x 1085mm Long Male/Female	1
5	10577.A0206	Pipe M12 x 740mm Long Male/Male	2
6	10542.A01	Stub Pipe	1
7	97S.1	Pipe Clip	2
8	110S.1	Nozzle	1
9	29S.7	Hose 3/4" Bore 700mm Long	1
10	10582.A01	Half Nut M12	2
11	97S.15	Pipe Clip	2
12	152S.3	Adaptor 3 way	1
13	10577.A0203	Pipe M12 x 500mm Long Male/Male (when fitted)....	1
14	10387.A01	Brake Switch Adaptor (when fitted)	1
15	116S.2	Copper Washer 7/16" I.D. (when fitted)	1
16	10744.A01	Brake Switch (when fitted)	1
17	10577.A0106	Pipe M12 x 465mm Long Male/Female (when fitted)..	1
18	8S.2A	Bolt M6 x 25mm Long (when fitted)	1
19	12S.14	Washer 6mm I.D. (when fitted)	1
20	7S.2	Nut M6 (when fitted)	1

BRAKE PIPES AND FITTINGS

SALISBURY AXLES (CALIPER DISC BRAKES)

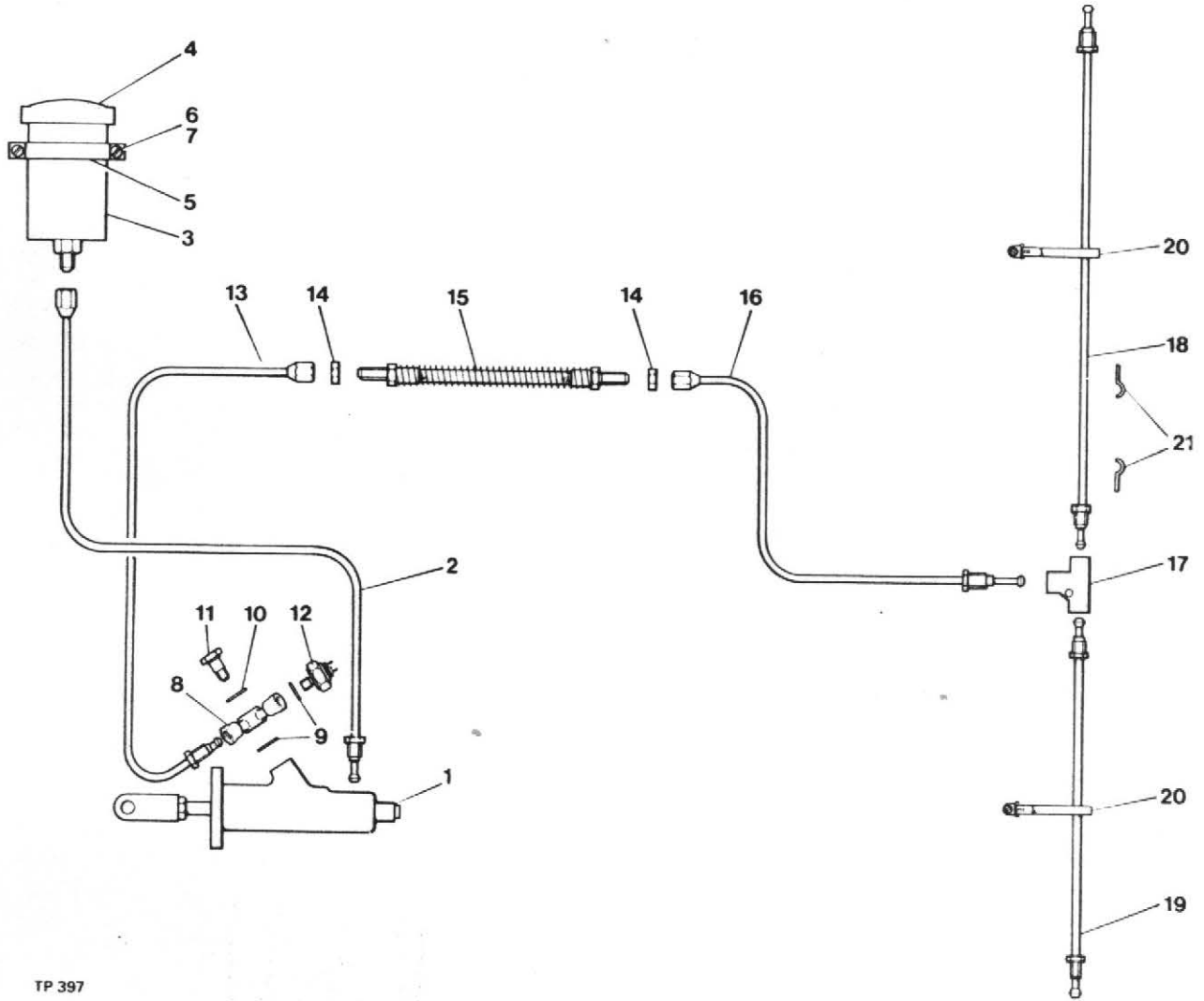

TP 397

Item No.	Part No.	Description	Qty.
1	20102.A03	Master Cylinder	1
2	DM 194-1	Pipe - Cylinder to Reservoir	1
3	10659.A01	Reservoir c/w Cap	1
4	10659.A0101	Cap - Reservoir	1
5	10659.A0102	Clip Reservoir	1
6	82S.3C	Screw Rd. Hd. Slot 2BA x ½" Long	2
7	85S.1	Nut - Self Locking 2BA	2
8	114S.1	Banjo - Double (if fitted)	1
9	116S.1	Washer - Copper (if fitted)	2
10	116S.2	Washer - Copper (if fitted)	1
11	115S.1	Banjo Bolt (if fitted)	1
12	FSE 337	Brake Switch (if fitted)	1
13	DM 79-9	Pipe - Banjo to Flexible Pipe	1
14	95S.3	Locknut	2
15	10658.A01	Flexible Pipe	1
16	DM 79-1	Pipe - Flexible Pipe to Tee Piece	1
17	121S.2	Tee Piece	1
18	DM 78-1	Pipe - Tee Piece to L.H. Caliper	1
19	DM 78-2	Pipe - Tee Piece to R.H. Caliper	1
20	97S.15	Jubilee Clip - R.H./L.H. Pipes	2
21	4S.133	Clip - Pipes to Diff. Case	2

HYDRAULIC RAM
 ROTATING SKIP AND TYPE A SKIP

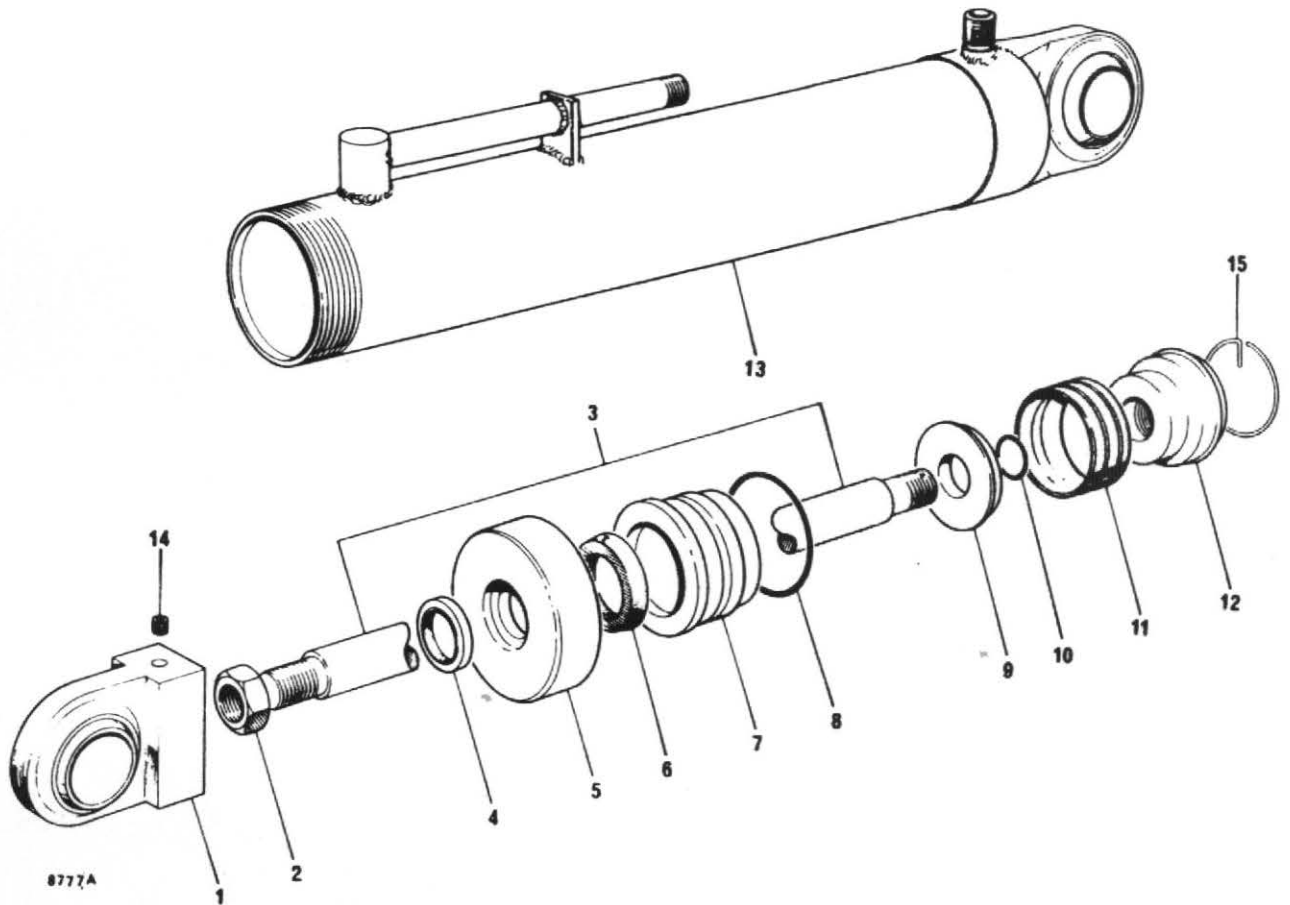

Item No.	Part No.	Description	Qty.
	30161.A01	Ram Complete	2
1	30121.A0101	Piston Rod Fitting	1
2	30121.A0102	Locknut	1
3	30161.A0101	Piston Rod	1
4	30121.A0104	Wiper	1
5	30121.A0105	Tube Cap	1
6	30121.A0106	Sleeve Seal	1
7	30121.A0107	Sleeve	1
8	30121.A0108	Sleeve 'O' Ring	1
9	30121.A0109	Backing Washer	1
10	30121.A0110	Piston 'O' Ring	1
11	30121.A0111	Piston Seal	1
12	30121.A0112	Piston Head	1
13	30161.A0102	Cylinder, Bosses & End Cap	1
14	30121.A0114	Grub Screw	1
15	30121.A0115	Spring Ring	1
	CSE 189	Seal Kit (Comprising items 4,6,8,10 & 11) ..	A/R

HYDRAULIC RAM (HIGH DISCHARGE SKIP)

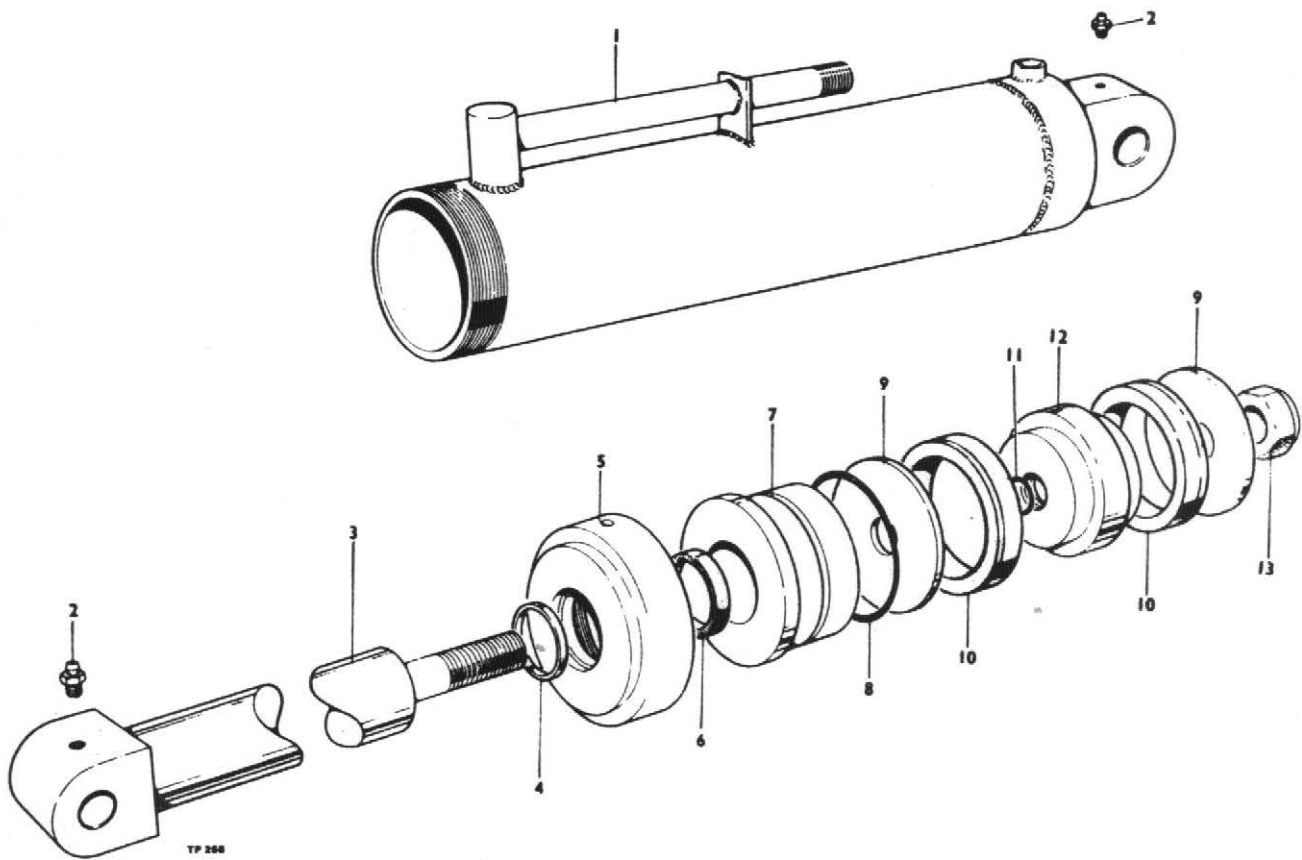

Item No.	Part No.	Description	Qty.
	30162.A01	Ram Assembly Complete (Two per high discharge m/c's only)	
1	30162.A0101	Ram Body	1
2	30162.A0102	Grease Nipple	2
3	30162.A0103	Piston Rod	1
4	30162.A0104	Wiper	1
5	30162.A0105	Tube Cap	1
6	30162.A0106	Sleeve Seal	1
7	30162.A0107	Sleeve	1
8	30162.A0108	Sleeve "O" Ring	1
9	30162.A0109	Backing Washer	2
10	30162.A0110	Piston Seal	2
11	30162.A0111	Piston "O" Ring	1
12	30162.A0112	Piston Head	1
13	30162.A0113	Lock Nut	1
	CSE 190	Seal Kit (comprising items 4,6,8,10 & 11)	A/R

HYDRAULIC RAM (STEERING)

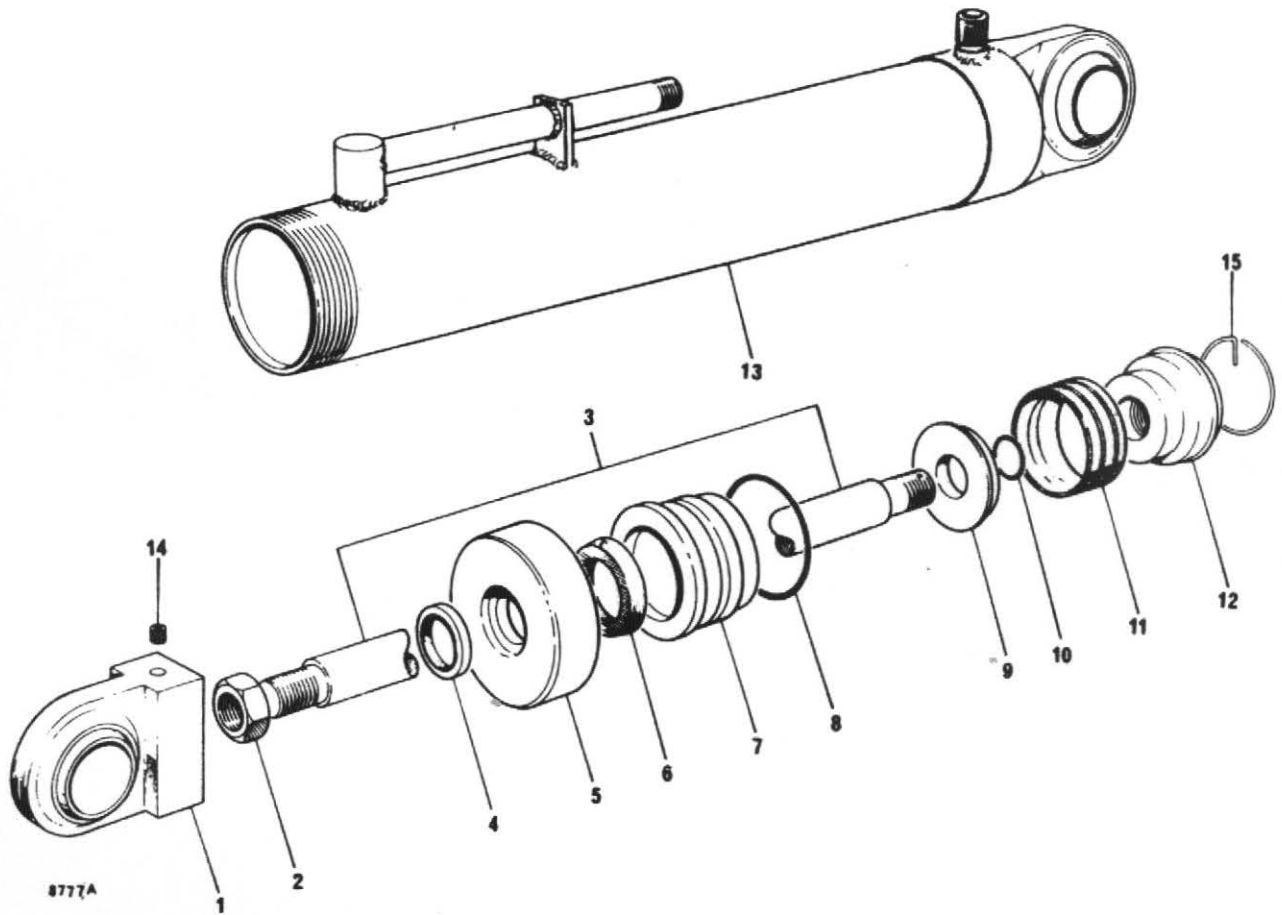

Item No.	Part No.	Description	Qty.
	30121.A01	Ram Complete (1 per Machine)	
1	30121.A0101	Piston Rod Fitting	1
2	30121.A0102	Locknut	1
3	30121.A0103	Piston Rod	1
4	30121.A0104	Wiper	1
5	30121.A0105	Tube Cap	1
6	30121.A0106	Sleeve Seal	1
7	30121.A0107	Sleeve	1
8	30121.A0108	Sleeve 'O' Ring	1
9	30121.A0109	Backing Washer	1
10	30121.A0110	Piston 'O' Ring	1
11	30121.A0111	Piston Seal	1
12	30121.A0112	Piston Head	1
13	30121.A0113	Cylinder, Bosses & End Cap	1
14	30121.A0114	Grub Screw	1
15	30121.A0115	Spring Ring	1
	CSE 189	Seal Kit (comprising items 4,6,8,10 & 11) ..	A/R

HYDRAULIC RAM

(TYPE B SKIP)

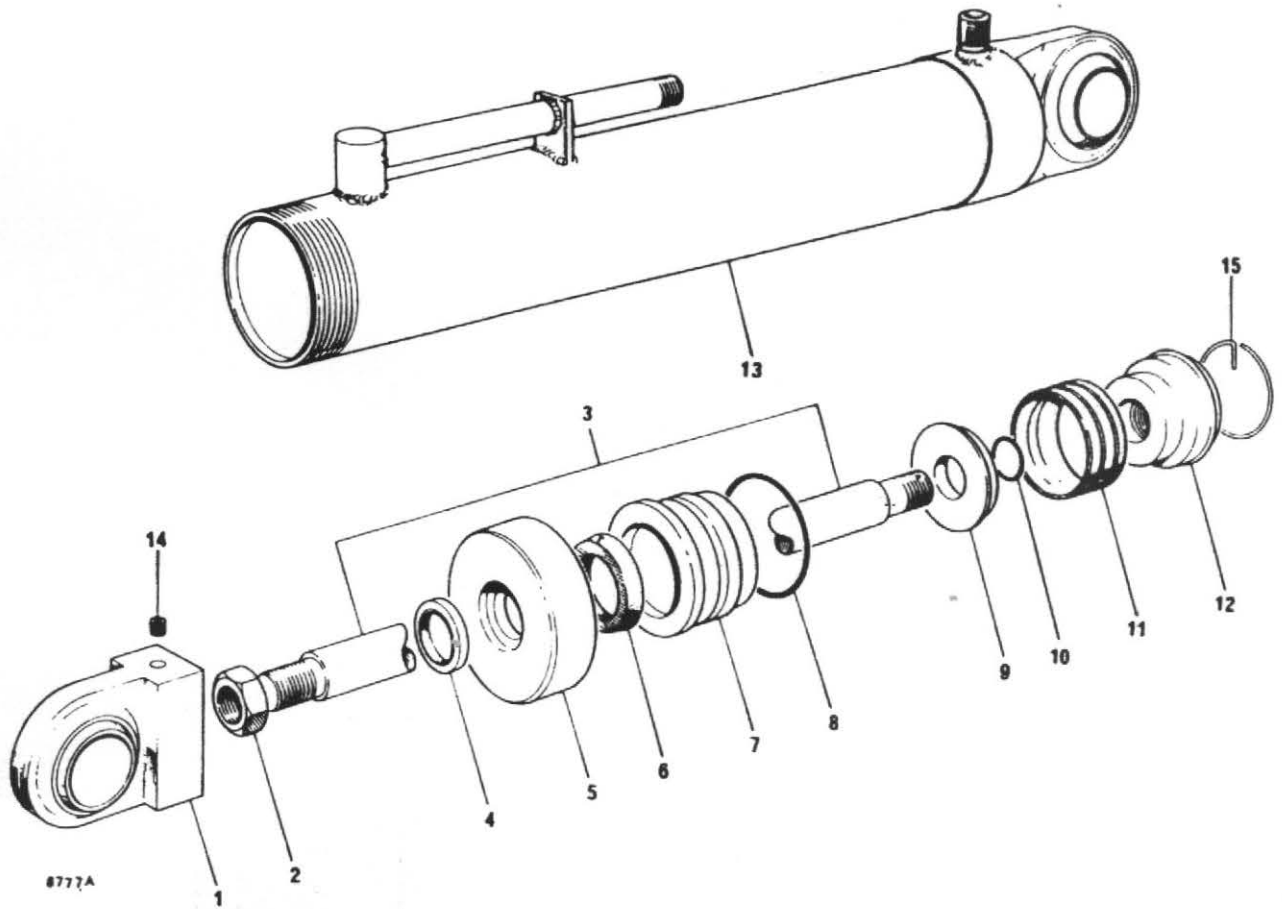

Item No.	Part No.	Description	Qty.
	30161.A04	Ram Complete	2
1	30121.A0101	Piston Rod Fitting	1
2	30121.A0102	Locknut	1
3	30161.A0101	Piston Rod	1
4	30121.A0104	Wiper	1
5	30121.A0105	Tube Cap	1
6	30121.A0106	Sleeve Seal	1
7	30121.A0107	Sleeve	1
8	30121.A0108	Sleeve 'O' Ring	1
9	30121.A0109	Backing Washer	1
10	30121.A0110	Piston 'O' Ring	1
11	30121.A0111	Piston Seal	1
12	30121.A0112	Piston Head	1
13	30161.A0102	Cylinder, Bosses & End Cap	1
14	30121.A0114	Grub Screw	1
15	30121.A0115	Spring Ring	1
16	10695.A02	Restrictor - Stroke (not illustrated)	2
	CSE 189	Seal Kit (Comprising items 4,6,8,10 & 11) ..	A/R

HYDRAULIC CONTROL VALVE

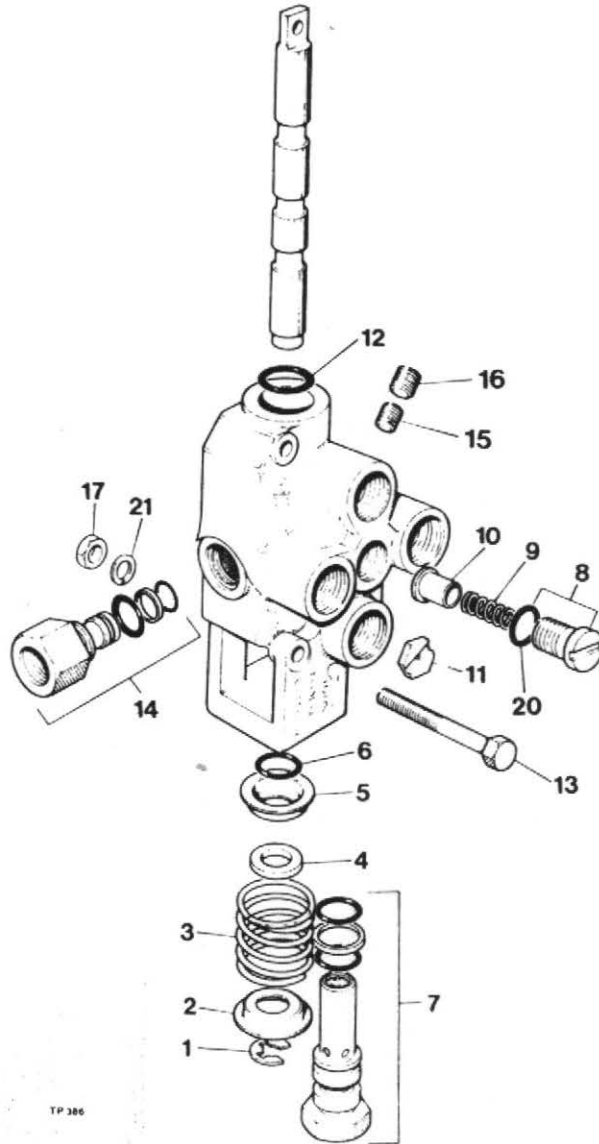

Item No.	Part No.	Description	Qty.
	30057.A01	Control Valve Complete	1
1	30131.A0101	Clip Ring	1
2	30131.A0102	Shallow Washer	1
3	30131.A0103	Spool Spring	1
4	30131.A0104	Washer Spacer	1
5	30131.A0105	Deep Washer	1
6	30057.A0101	"O" Ring	1
7	30057.A0102	Relief Valve Assembly	1
8	30057.A0103	Lift Check Plug Assembly	1
9	30131.A0109	Lift Check Spring	1
10	30131.A0110	Lift Check Plunger	1
11	30131.A0111	Orifice Plate	1
12	30057.A0104	"O" Ring	1
13	6S.3H	Bolt 5/16" UNF x 2½" Long	2
14	30057.A0105	Pressure Beyond Plug	1
15	30131.A0116	Plug 1/16"	1
16	30131.A0117	Plug 1/8"	1
17	9S.2	Nut 5/16" UNF	1
18	30057.A0106	Seal Repair Kit (Relief Valve).....	A/R
19	30057.A0107	Seal Repair Kit	A/R
20	30131.A0118	"O" Ring	1
21	41S.4	Spring Washer 5/16" Dia.....	2

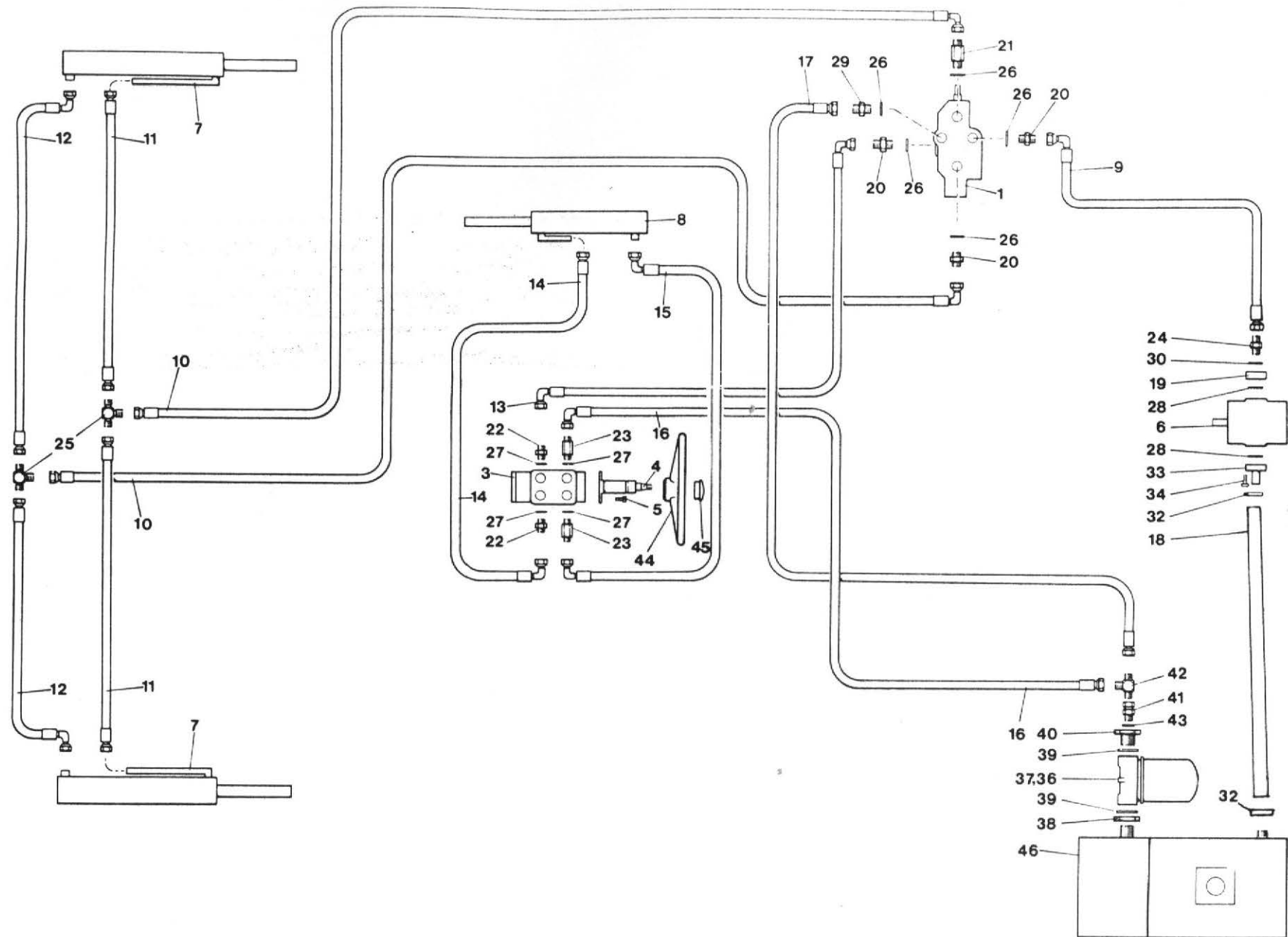

HYDRAULICS

Item No.	Part No.	Description	Qty.
1	30057.A01	Control Valve 030020443	1
3	CSE 178	Steering Valve complete (Danfoss)	1
4	CSE 178-2	Steering Valve (Danfoss)	1
4	CSE 178-1	Steering Column (Danfoss)(c/w Steering Wheel Nut)	1
5	103S.04B	Capscrew 3/8" UNC x 3/4" Long	2
	69S.03G	Bolt 3/8" UNC x 1 1/2" Long (Steering Valve Fixing- Danfoss)	2
	67S.04	Shakeproof Washer 3/8" dia. (Steering Valve Fixing- Danfoss)	2
	CSE 182	Steering Valve Spacer (Steering Valve Fixing - Danfoss)	2
6	10535.A01	Pump (Petter)	1
	10539.A01	Pump (Lister)	1
7	30161.A04	Hydraulic Cylinder (Skip)	2
8	30121.A01	Hydraulic Cylinder (Steering)	1
9	31S.02Q	Hose 3/8" x 34" Long ST x 90°	1
10	31S.02D	Hose 3/8" x 112" Long ST x 90°	2
11	35S.02I	Hose 3/8" x 25" Long ST x ST	2
12	31S.02AA	Hose 3/8" x 20" Long ST x 90°	2
13	36S.02II	Hose 3/8" x 89" Long 90° x 90° @ 270°	1
14	31S.02G	Hose 3/8" x 77" Long ST x 90°	1
15	36S.02HH	Hose 3/8" x 77" Long 90° x 90° @ 135°	1
16	31S.02E	Hose 3/8" x 99" Long ST x 90°	1
17	35S.03S	Hose 1/2" x 27" Long ST x ST	1
18	37S.01G	Hose 3/4" Cotton Braid x 30" Long	1
19	4-35-261	Adaptor Plate	1
20	CSE 186	Adaptor, Short 7/8" JIC. x 3/8" BSP	3
21	4-60-158	Adaptor, Long 7/8" JIC. x 3/8" BSP	1
22	4-35-40K	Adaptor, Short 3/4" UNF x 3/8" BSP	2
23	4-60-115	Adaptor, Long 3/4" UNF x 3/8" BSP	2
24	T.14J	Adaptor, 3/8" BSP x 3/8" BSP	1
25	4-35-388	Tee and Bracket Assembly	1
26	49S.01	"O" Ring	5
27	49S.02	"O" Ring	4
28	49S.11	"O" Ring	2
29	DSE 115	Adaptor 7/8" JIC. x 1/2" BSP	1
30	100S.03	Seal 3/8" BSP	1
32	97S.07	Hose Clip 1"-1,3/8"	2
33	10475.A01	Adaptor Plate	1
34	103S.03C	Capscrew 5/16" UNC x 1" Long	4
36	10363.A01	Return Line Filter	1
37	10363.A02	Filter Element	1
38	72S.07	Back Nut 1,1/4" BSP	1

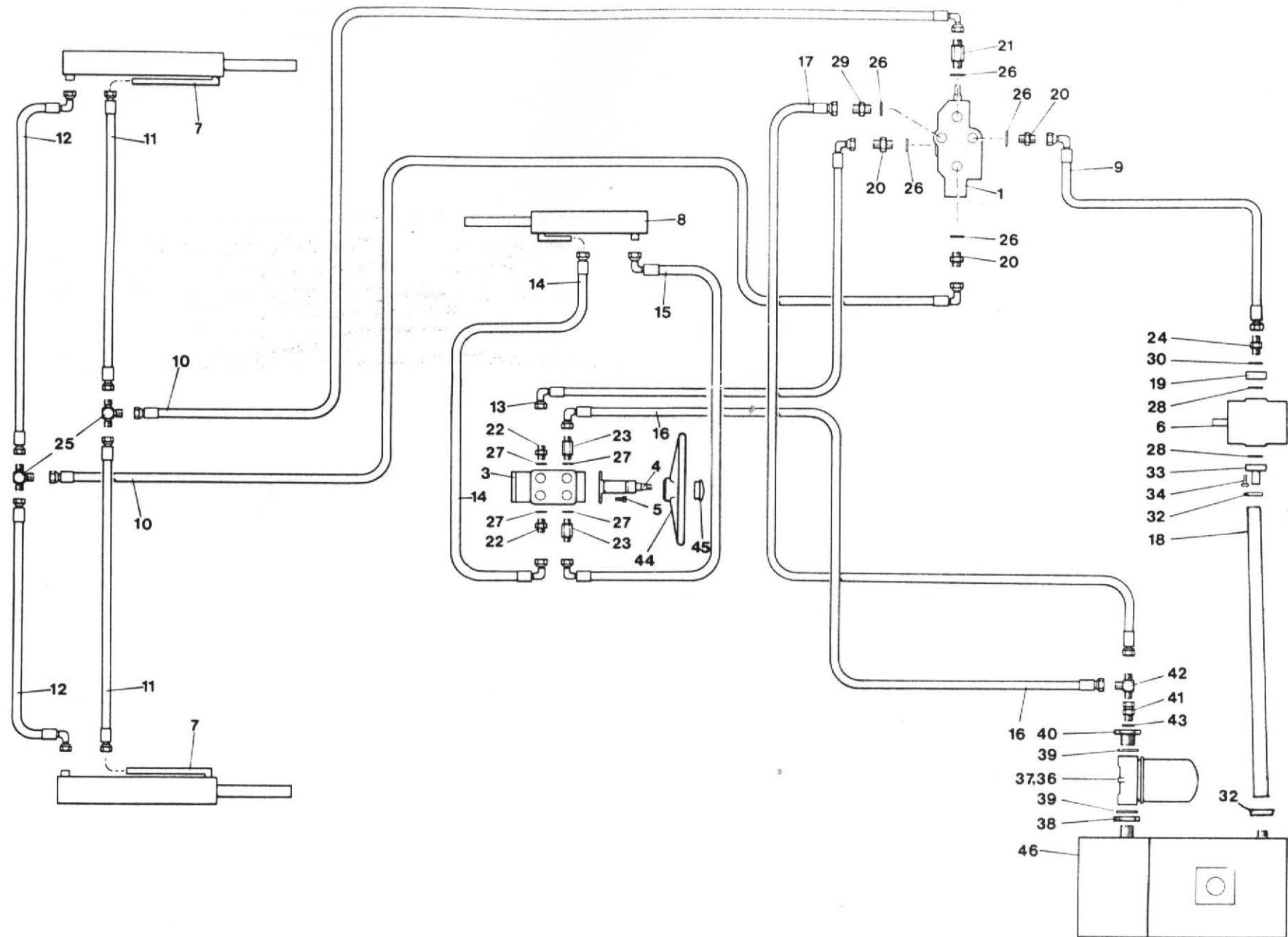

HYDRAULICS (Cont'd)

Item No.	Part No.	Description	Qty.
39	100S.09	Seal, 1,1/4" BSP	2
40	111S.01	Reducing Bush 1,1/4" Male x 1/2" Female BSP	1
41	112S.01	Adaptor Male/Female 1/2" BSP	1
42	113S.01	Unequal Male Tee 1/2" x 3/8" x 1/2" BSP	1
43	100S.04	Seal 1/2" BSP	1
44	40064.A01	Steering Wheel	1
45	10314.A01	Steering Wheel Cap	1
46	40282.A01	Hydraulic Tank	1
	177	Cable Tie (Not illustrated)	3

EXHAUST SYSTEM

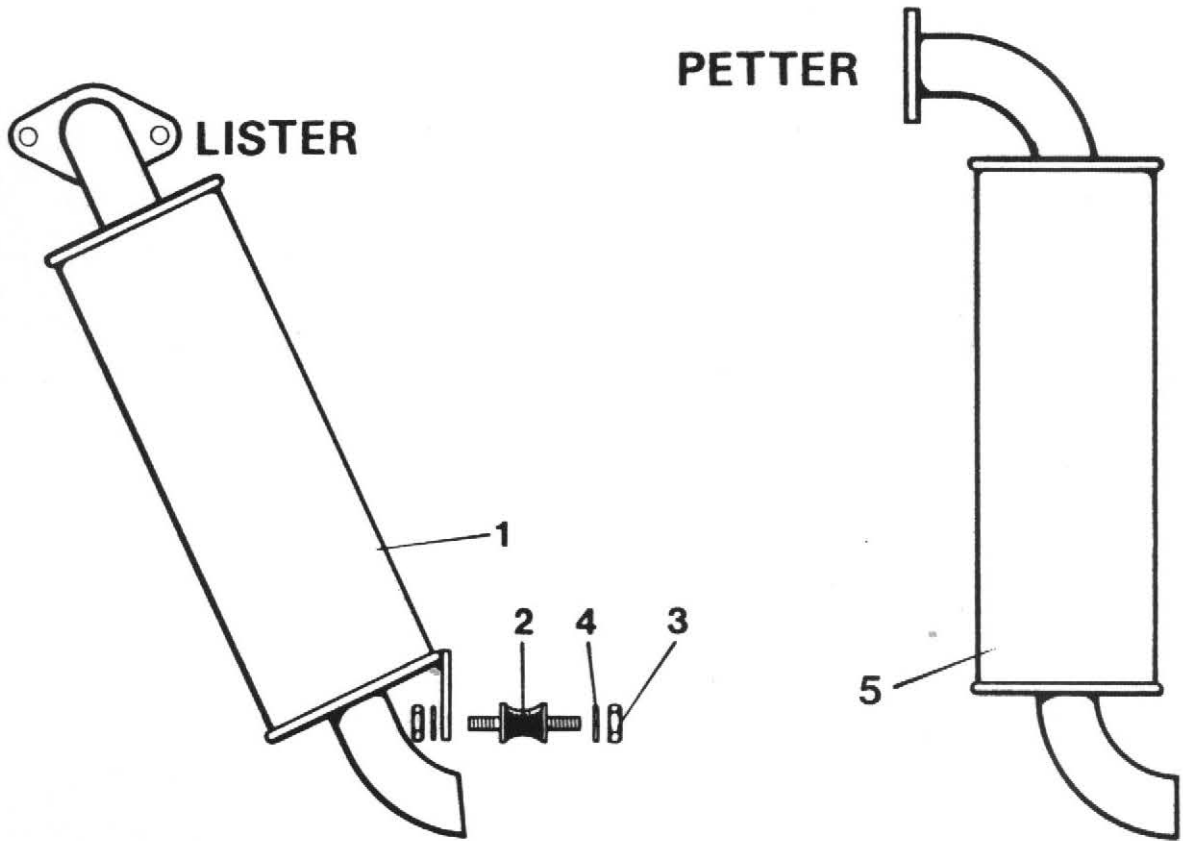

Item No.	Part No.	Description	Qty.
1	30154.A01	Exhaust (Lister)	1
2	10371.A01	Rubber Mounting	1
3	61S.3	Nut M8	2
4	12S.3	Washer 8mm Dia.	2
* 5	30154.A05	Exhaust (Petter)	1
	* 10293A02	" GASKET FOR ITEM 5	

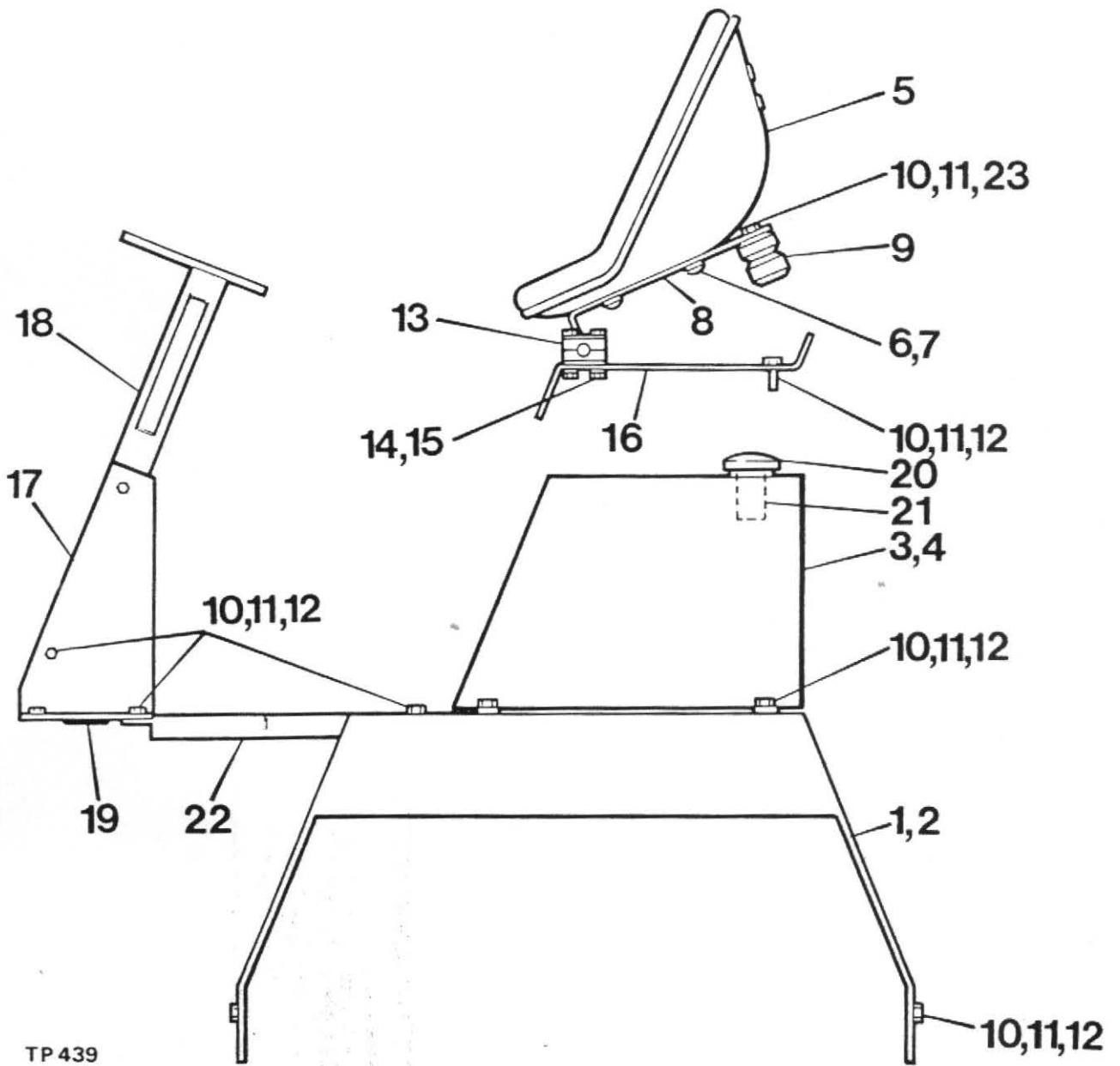

TP 439

MUDWINGS AND COVERS

Item No.	Part No.	Description	Qty.
1	40280.A01	Mudwing - L.H.	1
2	40279.A01	Mudwing - R.H.	1
3	40282.A01	Tank - L.H. (Hydraulic Oil)	1
4	40281.A01	Tank - R.H. (Diesel Oil) (Lister)	1
	40281.A04	Tank - R.H. (Diesel Oil) (Petter)	1
5	4-35-301	Seat	1
6	11S.38	Bolts - Seat M8 x 20	4
7	17A.4	Washers - Spring M8	4
8	30148.A02	Frame - Seat	1
9	10519.A01	Spring - Rubber	2
10	7S.04	Nut - Self Locking M10	A/R
11	11S.04C	Bolt - Hex. Hd. M10 x 25	A/R
12	12S.05	Washer - Plain 10 I.D.	A/R
13	10364.A02	Block - Pivot Assy.....	2
14	8S.02E	Bolts - Hex. Hd. M6 x 50	4
15	61S.02	Nut - Self Locking M6	4
16	30025.A03	Plate - Seat Support	1
17	30184.A02	Plate - Mounting	1
18	30125.A02	Column - Steering	1
19	4-35-375	Grommet	1
20	10378.A03	Cap - Filler	2
21	10379.A03	Strainer	2
22	30163.A02	Floorplate	1
23	C180B	Washer - Plain 3/8" I.D.	2

AIR CLEANER
(COOPERS)

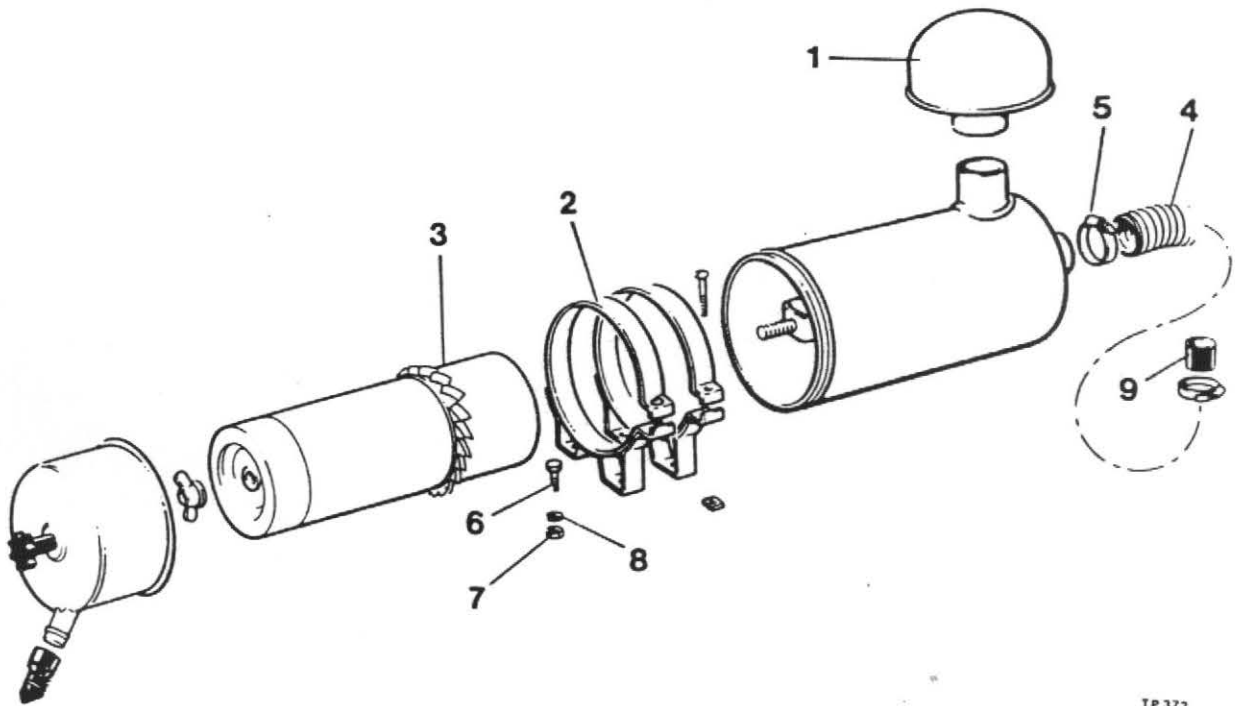

TP 372

Item No.	Part No.	Description	Qty.
	10532.A01	Air Cleaner	1
1	10534.A01	Stack Cap	1
2	10533.A01	Mounting Bands	2
3	10532.A0101	Element	1
4	10319.A03	Hose	1
5	97S.12	Hose Clip	2
6	8S.3A	Setscrew Hex. Hd. M8 x 25 Long	4
7	61S.3	Nut M8	4
8	12S.3	Washer M8	4
9	10320.A01	Pipe Adaptor	1

AIR CLEANER
(DONALDSON)

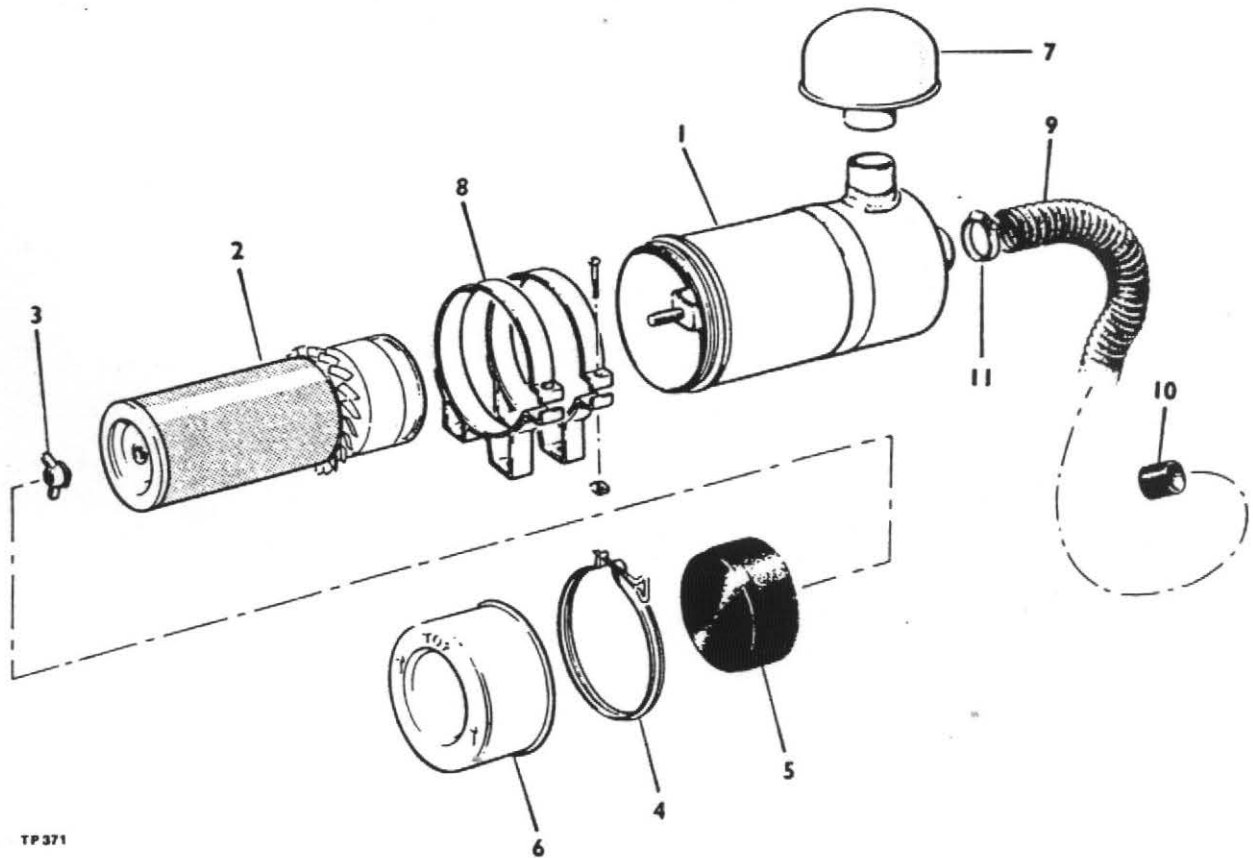

TP371

Item No.	Part No.	Description	Qty.
	10532.A02	Air Cleaner complete (items 1-6)	1
1	10532.A0201	Body	1
2	10532.A0101	Element	1
3	10532.A0202	Nut and Gasket	1
4	10532.A0203	Clamp	1
5	10532.A0204	Skirt, Baffle	1
6	10532.A0205	Cup	1
7	10534.A02	Stack Cap	1
8	10533.A02	Mounting Bracket	2
9	10319.A03	Hose	1
10	10320.A01	Pipe Adaptor	1
11	97S.12	Hose Clip	2
12	8S.3A	Setscrew Hex. Hd. M8 x 25mm Long (Not illustrated)	4
13	61S.3	Nut M8 (Not illustrated)	4
14	12S.3	Washer 8mm (Not illustrated).....	4

HIGH DISCHARGE SKIP AND FRAME

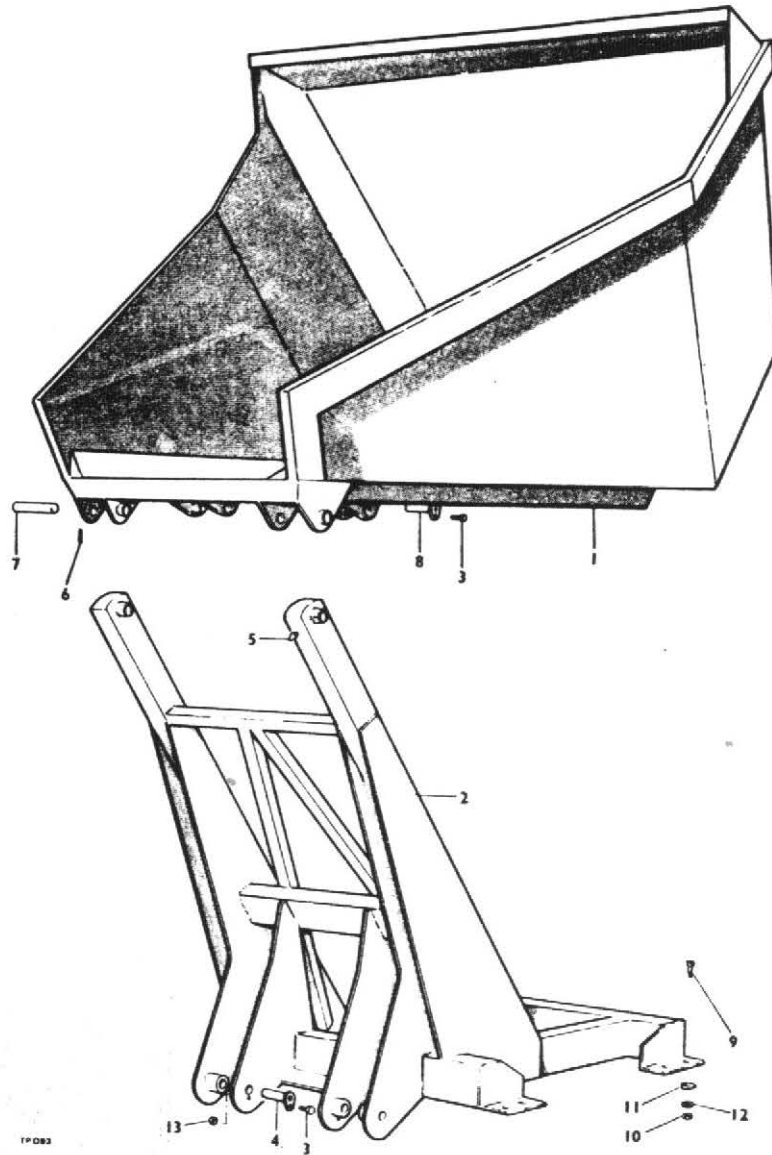

Item No.	Part No.	Description	Qty.
1	4-35-210	Skip	1
2	4-35-323	Frame	1
3	8S.3A	Bolt M8 x 25mm Long	4
4	4-35-226	Lower Ram Pin	2
5	131S.3	Grease Nipple	2
6	4-35-29A	Tension Pin 5/16" dia. x 2½" Long	2
7	5ST 84	Skip Pivot Pin	2
8	4-35-178	Ram Pin	2
9	8S.5E	Bolt Hex. Hd. M12 x 45 Long	8
10	7S.6	Locknut M12	8
11	105S.5	Taper Washer M12	8
12	12S.6	Plain Washer M12	8
13	7S.3	Nut M8	4

Note: Separate skip panels can be supplied - Details on application.

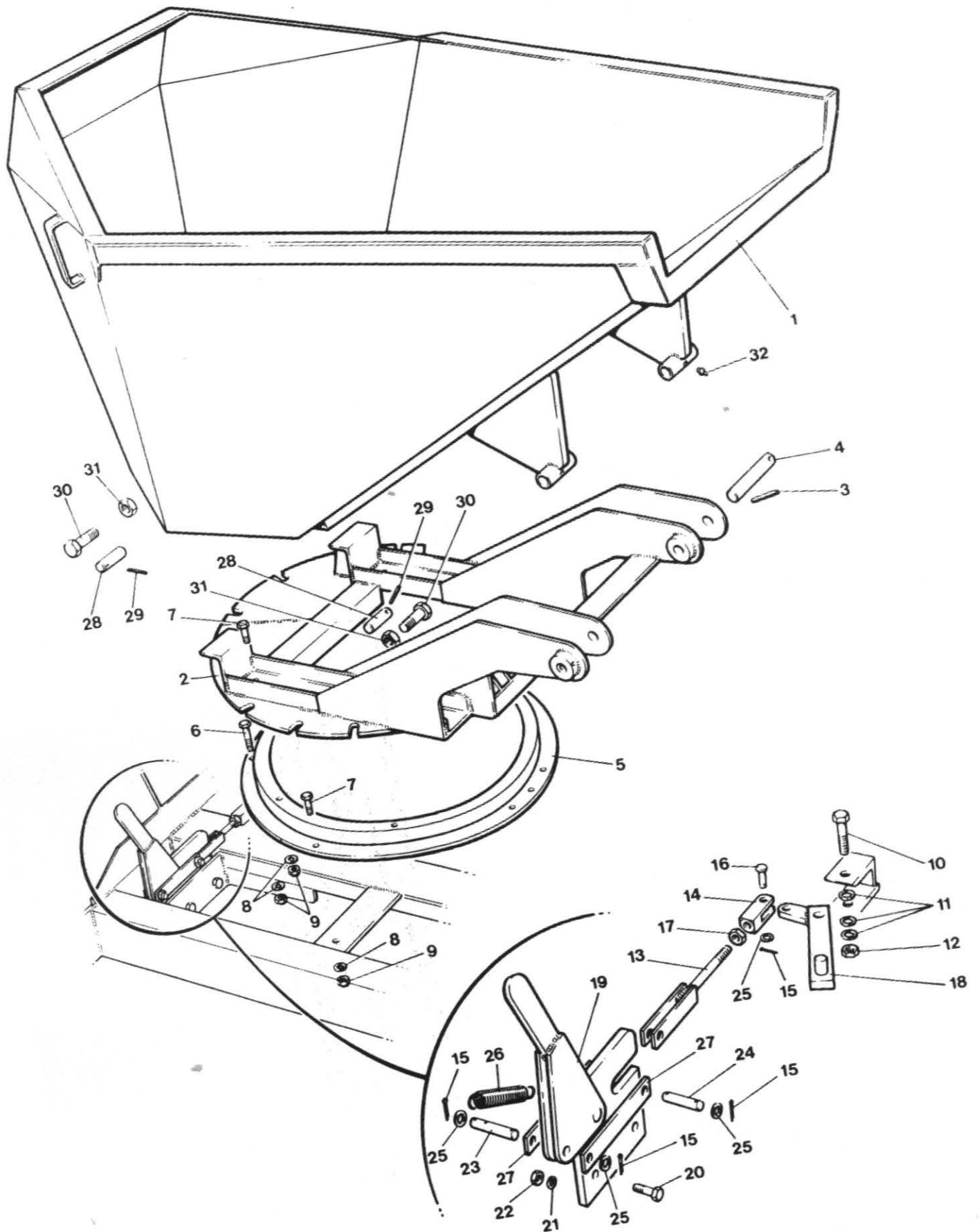

ROTATING SKIP & FRAME

Item No.	Part No.	Description	Qty.
1	40115.A01	Rotating Skip	1
2	40116.A01	Rotating Skip Frame	1
3	54S.8S	Pin - Slotted Tubular	2
4	10522.A01	Pin - Pivot	2
5	ASE 197	Ring-Turntable	1
6	8S.5M	Bolt - Hex. Hd. M12 x 80 Long	2
7	8S.5D	Bolt - Hex. Hd. M12 x 40 Long	7
8	12S.6	Washer - Plain	9
9	61S.5	Nut - Self Locking - 'Binx' M12	9
10	8S.6L	Bolt - Hex. Hd. M16 x 75 Long	1
11	12S.22	Washer - Plain	3
12	61S.6	Nut - Self Locking - 'Binx' M16	1
13	10651.A01	Rod	1
14	C174-H	Clevis End	1
15	44S.3C	Pin - Split 1/8" dia. x 1" Long	5
16	10650.A04	Pin - Clevis	1
17	2S.5	Nut - Hex. Full 1/2" BSF	1
18	10649.A01	Catch	1
19	20214.A01	Lever & Bracket (complete)	1
20	8S.5C	Bolt - Hex. Hd. M12 x 35 Long	2
21	12S.6	Washer - Plain	2
22	61S.5	Nut - Self Locking - 'Binx' M12	2
23	2ST-114	Pin	1
24	2ST-115	Pin	1
25	10S.4	Washer - Plain	5
26	C173B	Spring	1
27	2ST-112-5	Link	2
28	10739.A02	Pin - Cylinder Pivot (when fitted)	4
29	54S.7P	Pin - Slotted Tubular (when fitted)	4
30	4/35-110	Bolt-(Skip Ram) Hex. Hd. (when fitted)	4
31	74S.10	Nut - Half (Skip Ram) (when fitted)	4
32	131S.3	Grease Nipple	2

Note: Separate skip panels can be supplied - Details on application.

**FORWARD TIP SKIP
TYPE B**

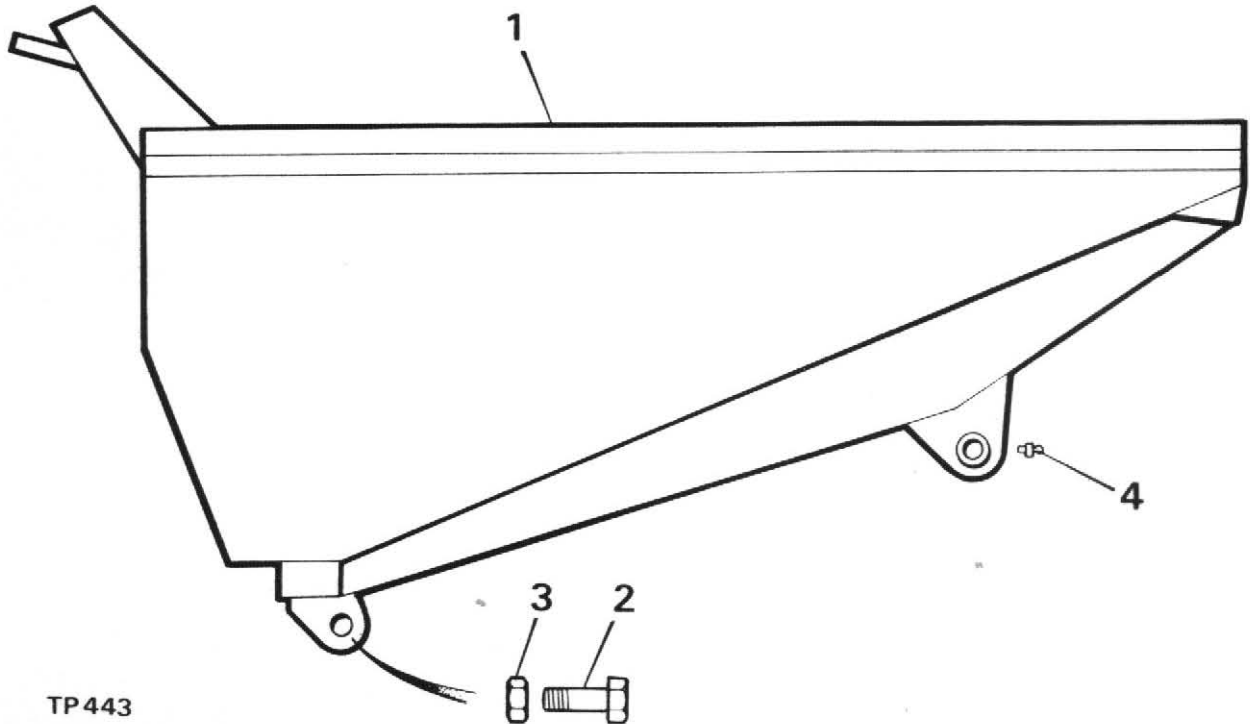

Item No.	Part No.	Description	Qty.
1	40275.A01	Skip - Standard	1
2	4-35-110	Bolt - Skip Ram 1½" UNF x 3¼" Long	2
3	74S.10	Nut - 1½" UNF	2
4	131S.03	Nipple - Grease	2
	45S.05	Loctite (Not illus.)Use on assembly of items 2 & 3 A/R	

**FORWARD TIP SKIP
TYPE A**

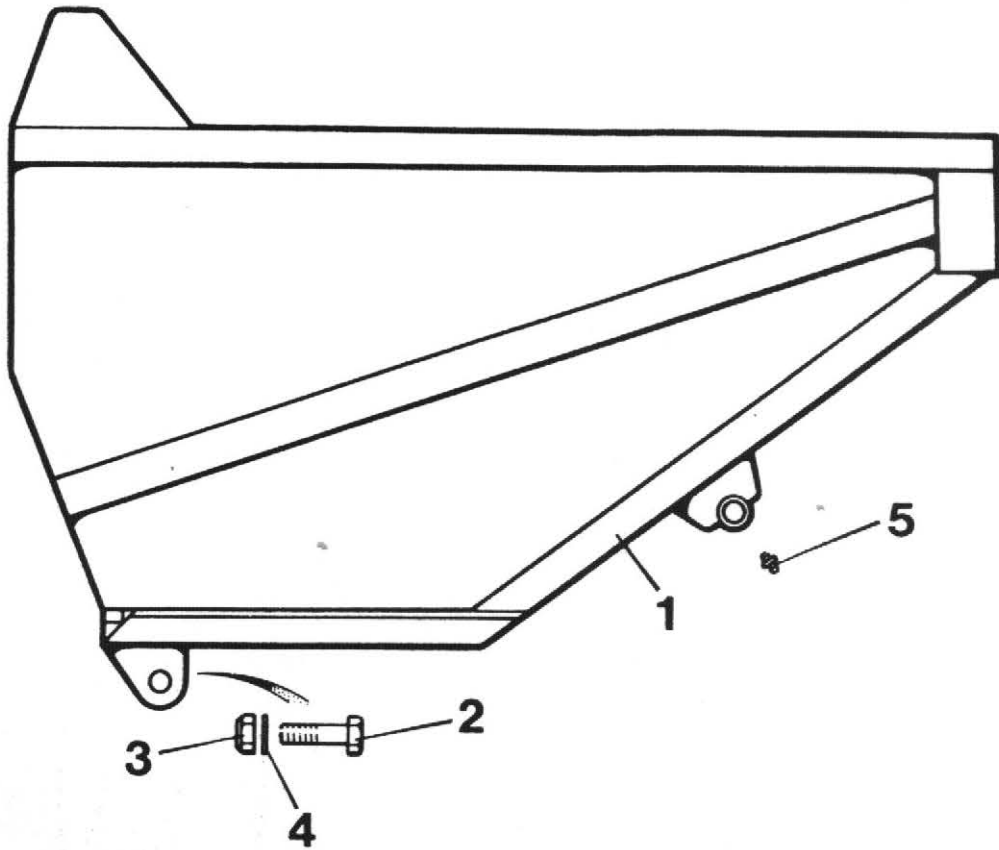

TP 389

1	40089.A02	Skip - Option	1
2	4-35-110	Bolt - Skip Ram 1½" UNF x 3½" Long	2
3	74S.10	Nut - 1½" UNF	2
4	67S.13	Washer - Shakeproof - internal	2
5	131S.03	Nipple - Grease	2

FUEL SYSTEM

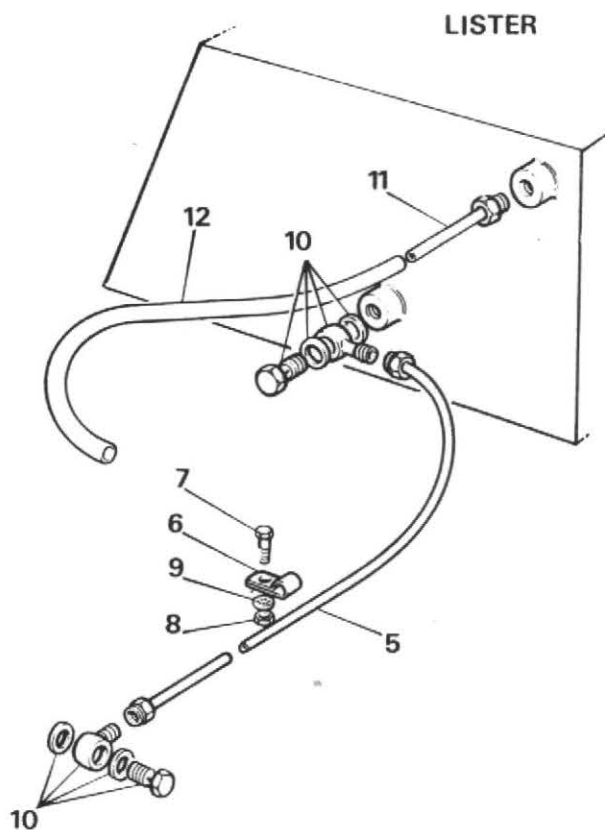
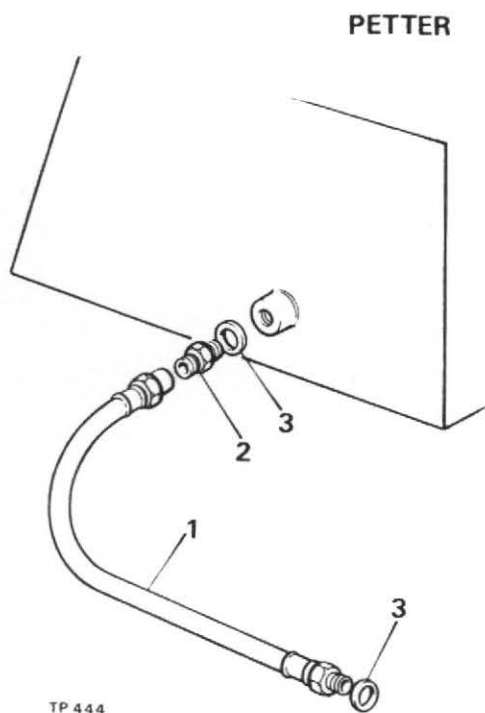

Item No.	Part No.	Description	Qty.
1	10605.A01 *	Pipe - Flexible - Tank to Filter	1
2	4-60-189 *	Coupling - Stud - Flexible Pipe to Tank	1
3	4-35-364 *	Washer - Fibre - Flexible Pipe to Filter & Tank.	2
5		+ Pipe - Tank to Filter	1
6	10350.A01 +	Clip - Pipe	1
7	64S.03 +	Setscrew - Hex. Hd. M6 x 25 Long	1
8	6SS.02 +	Nut - Hex. M6	1
9	13S.02 +	Washer - Shakeproof 6 I.D.	1
10	117S.02 +	Coupling - Banjo - Assembly	2
11		+ Pipe - Flexible - Leak Back	1
12		+ Tube - Bleed (Lister only)	1

* Petter Engines
+ Lister Engines

WHEELS AND TYRES

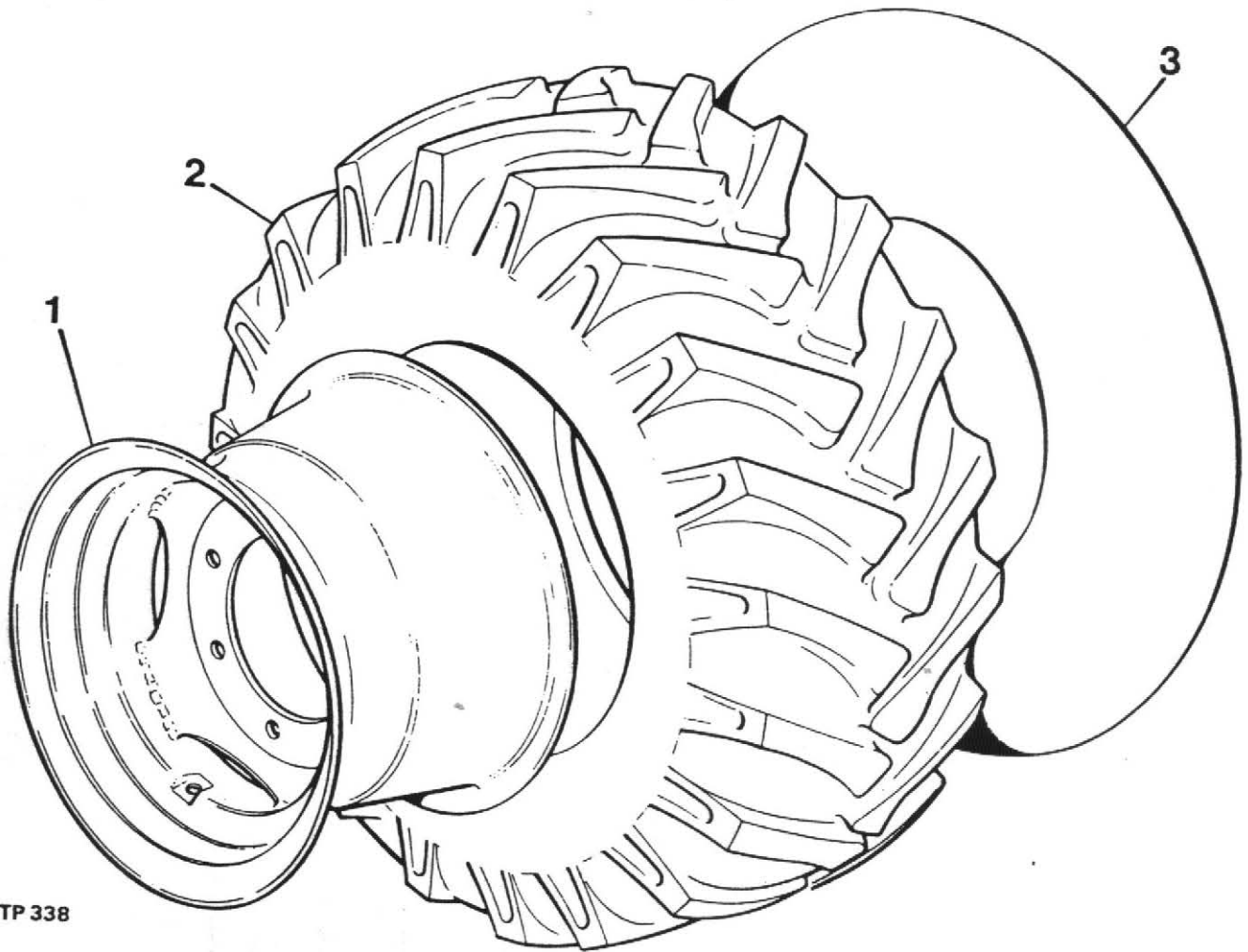

TP 338

Item No.	Part No.	Description	Qty.
	24S.29	Wheel - L.H. complete	2
	24S.30	Wheel - R.H. complete	2
1	20131.A03	Wheel	4
2	20S.17	Tyre - 10.0/75 x 15 x 8 Ply	4
3	23S.11	Tube - 10.0 x 15	4
		(Alternative)	
	24S.05	Wheel - L.H. complete	2
	24S.06	Wheel - R.H. complete	2
1	20131.A02	Wheel	4
2	20S.13	Tyre - 11.5/80 x 15 x 8 Ply	4
3	23S.08	Tube - 11.5 x 15	4
		(Alternative)	
	24S.25	Wheel - L.H. complete	2
	24S.26	Wheel - R.H. complete	2
1	30192.A03	Wheel	4
2	20S.08	Tyre - 7.50 x 16 x 6 Ply	4
3	23S.03	Tube - 7.50 x 16	4
	10668.A01	Nut (Not illustrated)	20
	C177	Nut (Not illustrated) Alternative	20

WIRING DIAGRAM (ELECTRICAL SYSTEM)

(LISTER)

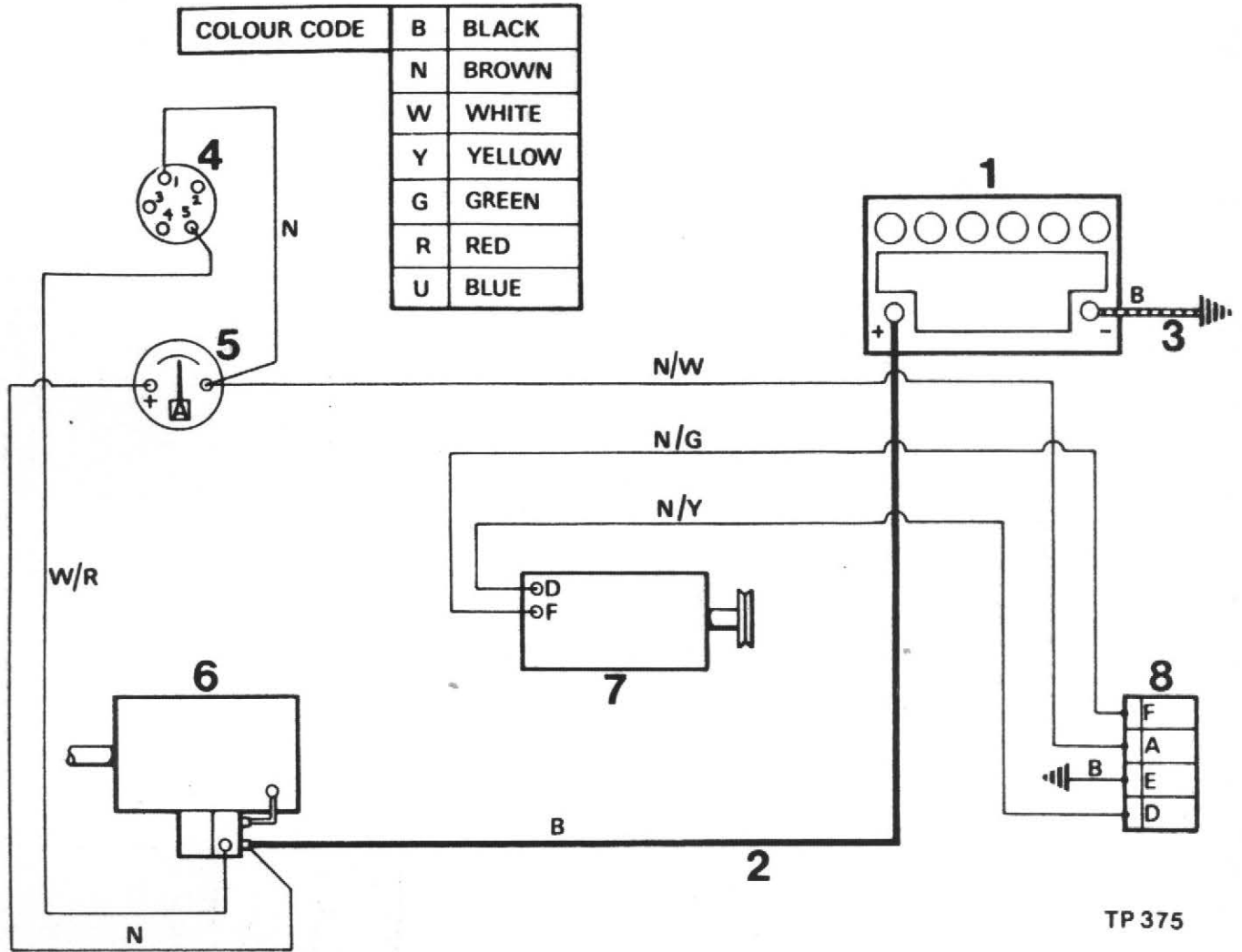

TP 375

Item No.	Part No.	Description	Qty.
1	109S.1	Battery	1
	109S.3	Battery (Alternative)	1
2	10227.A01	Positive Cable c/w End Fittings	1
3	10228.A01	Negative Cable c/w End Fittings	1
4	10614.A02	Switch c/w Keys	1
5	10612.A02	Ammeter	1
6	10613.A02	Starter Motor & Solenoid	1
7	10610.A02	Generator	1
8	10611.A02	Regulator	1
9	20105.A01	Wiring Harness Complete (Not Illustrated) ..	1
10	FSE 448	Adhesive Clip (Large) (Not Illustrated)	A/R
11	FSE 449	Adhesive Clip (Small) (Not Illustrated)	A/R

WIRING DIAGRAM (ELECTRICAL SYSTEM)

PETTER

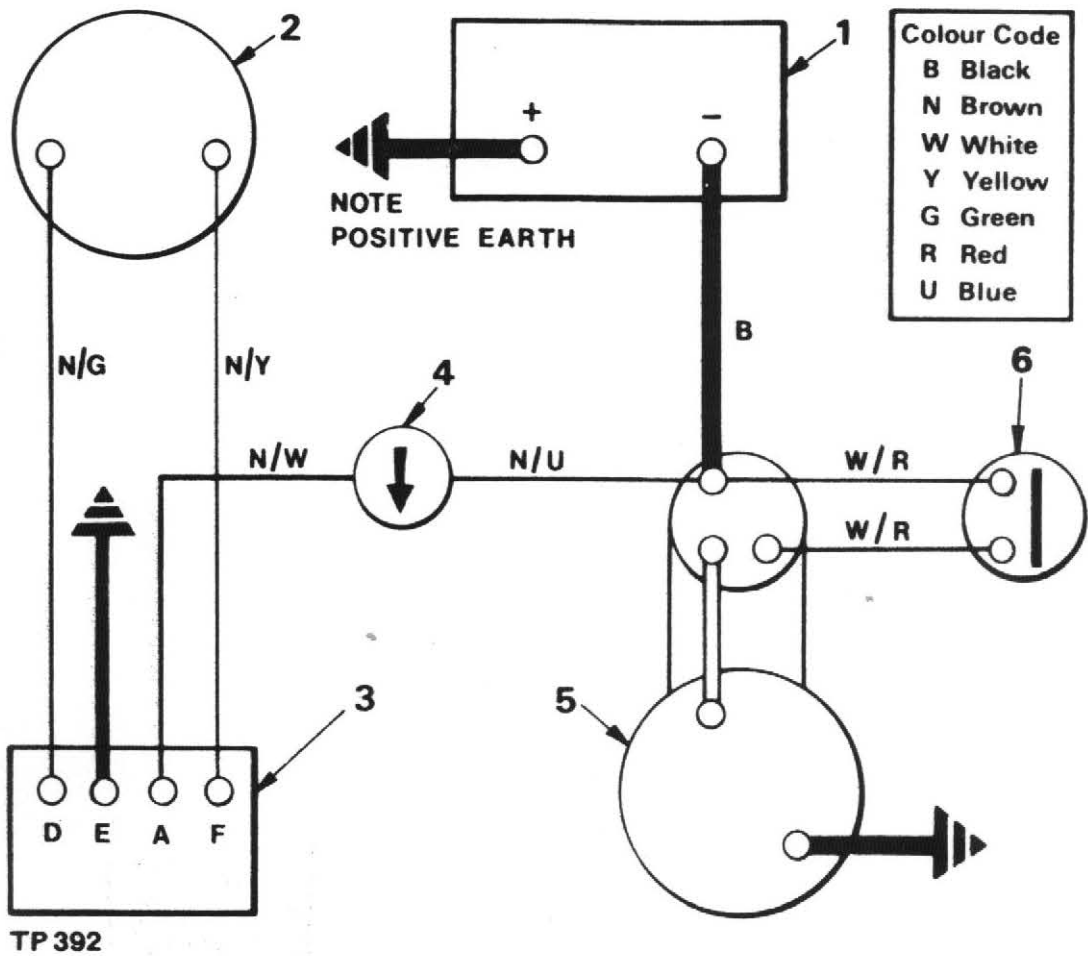

Item No.	Part No.	Description	Qty.
	109S.1	Battery	1
1	109S.3	Battery (Alternative)	1
2	10610.A01	Dynamo	1
3	10611.A02	Regulator	1
4	10612.A02	Ammeter	1
5	10613.A01	Starter c/w Solenoid	1
6	10614.A01	Starter Switch	1
	201105.A02	Wiring Harness (Not illustrated)	1

WIRING DIAGRAM
(FULL ROAD LIGHTING KIT)
(PETTER & LISTER)

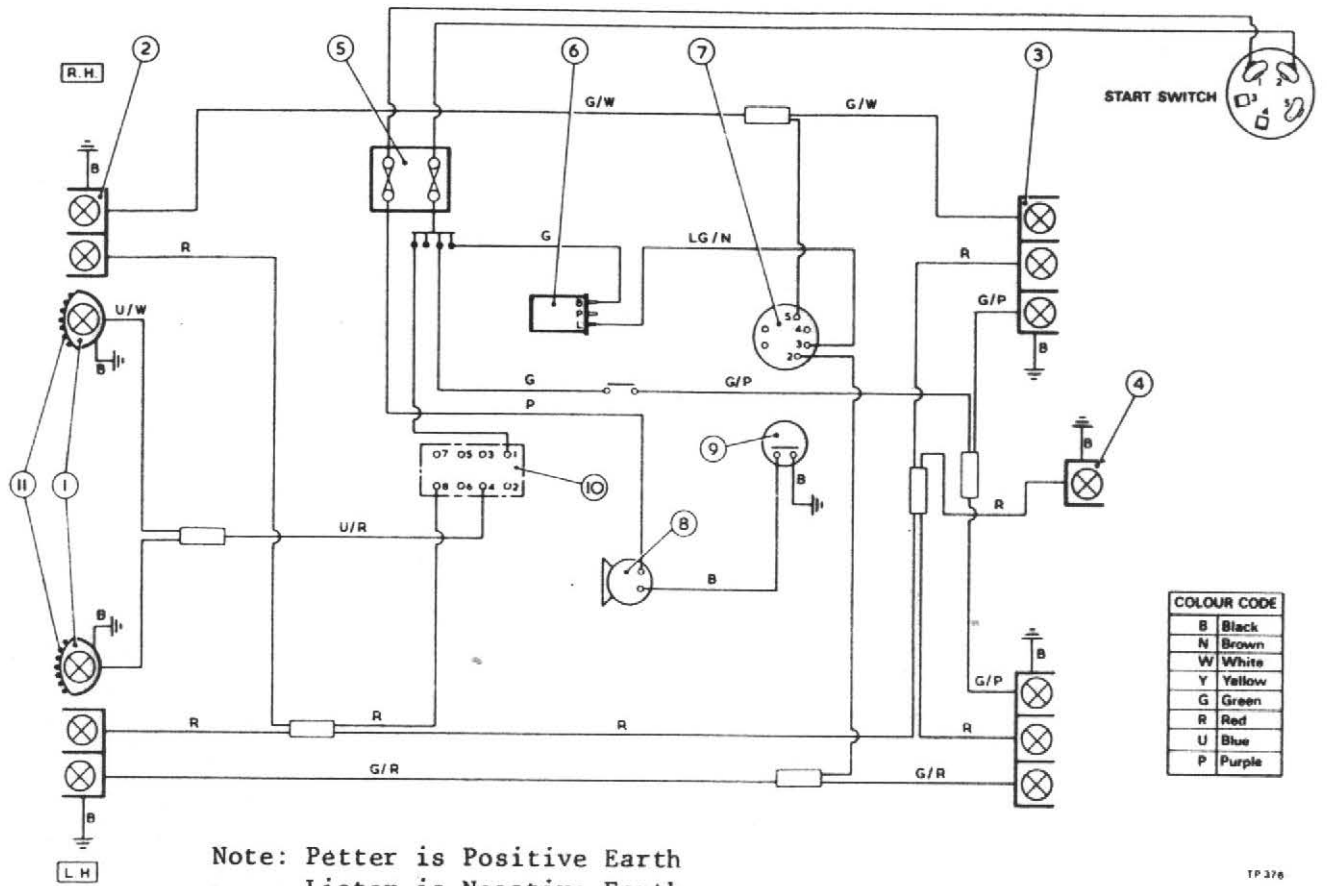

COLOUR CODE	
B	Black
N	Brown
W	White
Y	Yellow
G	Green
R	Red
U	Blue
P	Purple

TP 376

Item No.	Part No.	Description	Qty.
1	20013.A0112	Headlight	2
2	FSE.333	Side Light/Indicator	2
3	FSE.334	Rear Light/Indicator	2
	82S.3E	Screw Rd. Hd. 2BAx $\frac{1}{2}$ " Lg.-Side & Rear Lights	16
	85S.1	Nut Selflocking 2BA-Side & Rear Lights	16
	12S.1	Washer Plain-Side & Rear Lights	16
4	10615.A01	Number Plate Light	1
5	10644.A01	Fuse Box	1
6	10616.A01	Flasher Unit	1
	82S.3C	Screw Rd. Hd. 2BA x $\frac{1}{2}$ " Lg.-Flasher Unit	1
	12S.1	Washer Plain 2BA - Flasher Unit	1
	85S.1	Nut Selflocking 2BA - Flasher Unit	1
7	10617.A01	Indicator Switch	1
	82S.7C	Screw Rd. Hd. 6BA x $\frac{1}{2}$ " Lg.-Indicator Switch	2
	85S.3	Nut Selflocking 6BA - Indicator Switch.....	2
8	10618.A01	Horn c/w Bracket	1
	85S.3	Nut Selflocking 6BA - Horn	2
9	10619.A01	Horn Button	1
	82S.7E	Screw Rd. Hd.	2
	85S.3	Nut Selflocking	2
10	10620.A01	Light Switch c/w Bezel	1
11	10216.A01	Stone Guard - Headlights	2

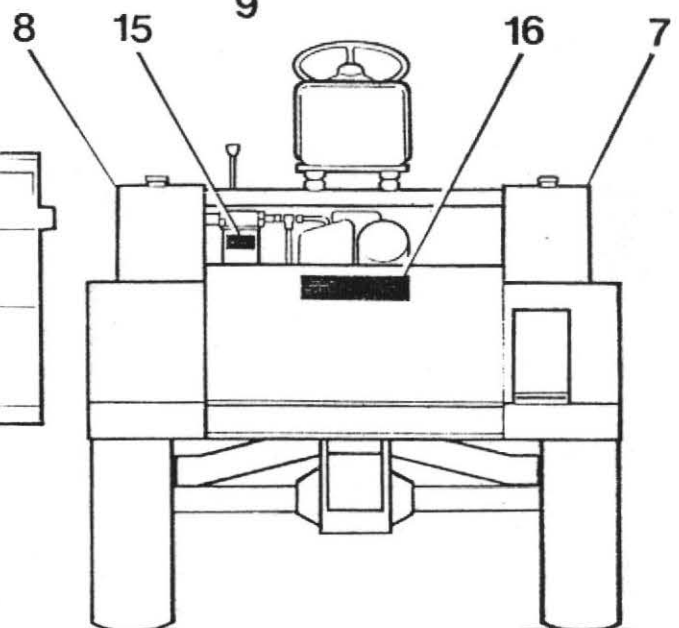
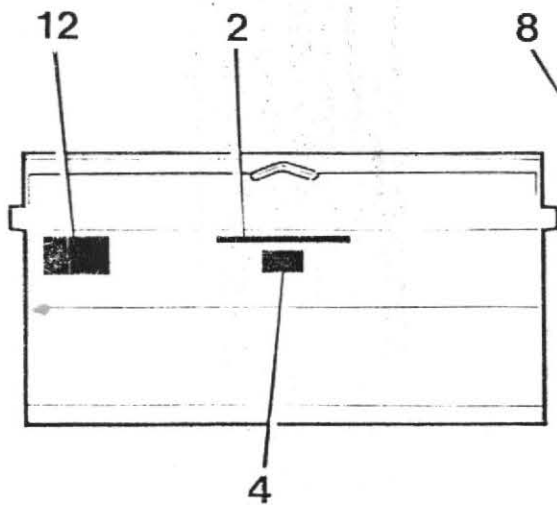
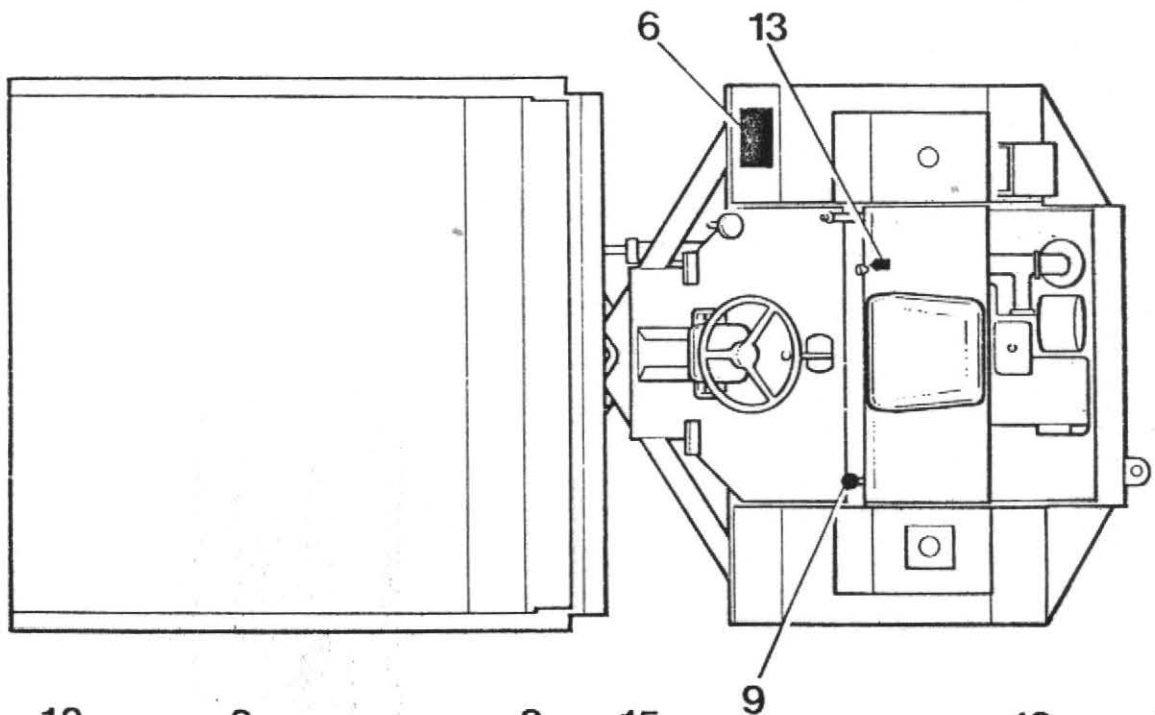
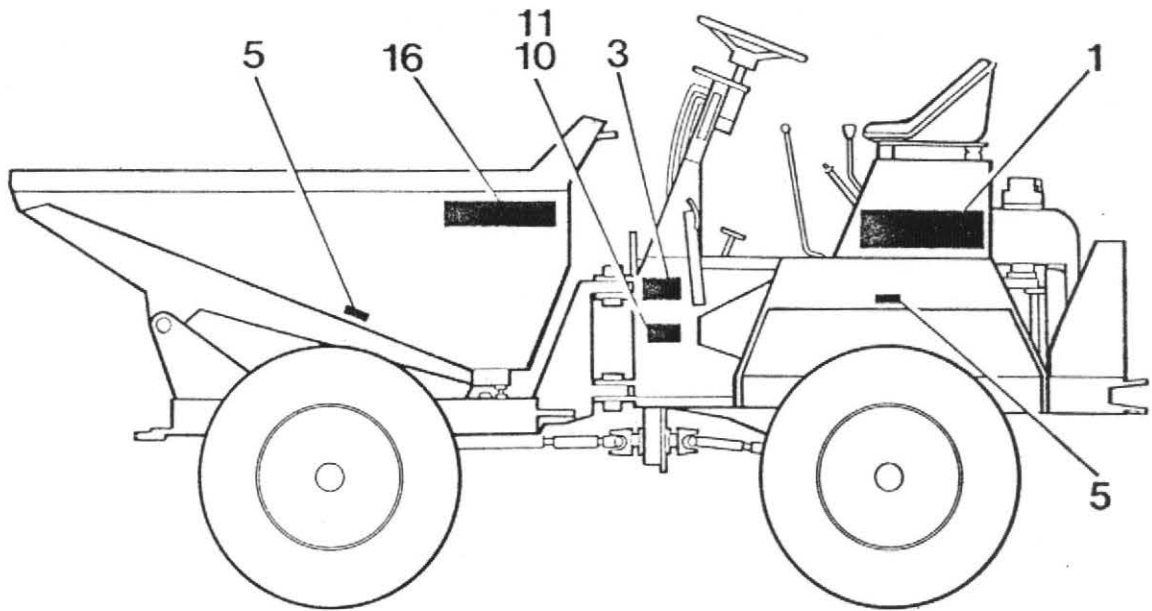

TP446

LABELS

Item No.	Part No.	Description	Qty.
1	20235.A01	Machine Identification	2
2	20235.A04	Machine Identification	2
3	10541.A02	Payload Label	1
4	10541.A07	Payload Label	1
5	DM.198	Steering Lock Warning	2
6	DM.157	Warning Label (Skip)	1
7	10540.A02	Tyre Pressure Label	4
8	20132.A03	Dumper Safety Label	1
9	10546.A03	Diesel Fuel Label	1
10	10546.A04	Hydraulic Oil Only	1
11	10284.A01	Dump Return Label	1
12	10317.A02	Chassis Label	1
13	DM.197	Lubrication Label (Salisbury)	1
14	DM.196	Lubrication Label (Newage)	1
15	FSE 357	Engine Stop Label	1
16	ESE 286	Engine Stop Label	1
17	4-60-233-2	Positive Earth Label	1
18	10S.05D	Pop Rivets	10
19	15S.01A	Hammer Drive Screws	4
20	10469.A01	Operators Handbook & Parts List	1
21	10215.A02	Filter Instruction Label	1
22	10215.A03	Filter Instruction Label	1
23	10479.A01	Winget Label	3
24	10541.A03	Payload Label (R. Skip only)	1
25	10541.A08	Payload Label (R. Skip only)	1
26	10536.A02	Warning - Materials (R.S. & H.D. Skips only) ...	1

DECIMAL, FRACTIONAL AND METRIC EQUIVALENTS

Inches		Milli- metres	Inches		Milli- metres
Fractions	Decimals		Fractions	Decimals	
1/64	0.015625	0.397	33/64	0.515625	13.097
1/32	0.03125	0.794	17/32	0.53125	13.494
3/64	0.046875	1.191	35/64	0.546875	13.891
1/16	0.0625	1.588	9/16	0.5625	14.288
5/64	0.078125	1.984	37/64	0.578125	14.684
3/32	0.09375	2.381	19/32	0.59375	15.081
7/64	0.109375	2.778	39/64	0.609375	15.478
1/8	0.125	3.175	5/8	0.625	15.875
9/64	0.140625	3.572	41/64	0.640625	16.272
5/32	0.15625	3.969	21/32	0.65625	16.669
11/64	0.171875	4.366	43/64	0.671875	17.066
3/16	0.1875	4.763	11/16	0.6875	17.463
13/64	0.203125	5.159	45/64	0.703125	17.859
7/32	0.21875	5.556	23/32	0.71875	18.256
15/64	0.234375	5.953	47/64	0.734375	18.653
1/4	0.250	6.350	3/4	0.750	19.050
17/64	0.265625	6.747	49/64	0.765625	19.447
9/32	0.28125	7.144	25/32	0.78125	19.844
19/64	0.296875	7.541	51/64	0.796875	20.241
5/16	0.3125	7.938	13/16	0.8125	20.638
21/64	0.328125	8.334	53/64	0.828125	21.034
11/32	0.34375	8.731	27/32	0.84375	21.431
23/64	0.359375	9.128	55/64	0.859375	21.828
3/8	0.375	9.525	7/8	0.875	22.225
25/64	0.390625	9.922	57/64	0.890625	22.622
13/32	0.40625	10.319	29/32	0.90625	23.019
27/64	0.421875	10.716	59/64	0.921875	23.416
7/16	0.4375	11.113	15/16	0.9375	23.813
29/64	0.453125	11.509	61/64	0.953125	24.209
15/32	0.46875	11.906	31/32	0.96875	24.606
31/64	0.484375	12.303	63/64	0.984375	25.003
1/2	0.500	12.700	1	1.000	25.400

INCHES INTO MILLIMETRES

Inches	0	1	2	3	4	5	6	7	8	9
0	0	25.40	50.80	76.20	101.60	127.00	152.40	177.80	203.20	228.60
10	254.00	279.40	304.80	330.20	355.60	381.00	406.40	431.80	457.20	482.60
20	508.00	533.40	558.80	584.20	609.60	635.00	660.40	685.80	711.20	736.60
30	762.00	787.40	812.80	838.20	863.60	889.00	914.40	939.80	965.20	990.60
40	1016.00	1041.40	1066.80	1092.20	1117.60	1143.00	1168.40	1193.80	1219.20	1244.60
50	1270.00	1295.40	1320.80	1346.20	1371.60	1397.00	1422.40	1447.80	1473.20	1498.60
60	1524.00	1549.40	1574.80	1600.20	1625.60	1651.00	1676.40	1701.80	1727.20	1752.60
70	1778.00	1803.40	1828.80	1854.20	1879.60	1905.00	1930.40	1955.80	1981.20	2006.60
80	2032.00	2057.40	2082.80	2108.20	2133.60	2159.00	2184.40	2209.80	2235.20	2260.00
90	2286.00	2311.40	2336.80	2362.20	2387.60	2413.00	2438.40	2463.80	2489.20	2514.61

Use in conjunction with above table.

Example: Find equivalent mm. for 84 5/8".

84" = 2133.60 mm.

5/8" = 15.875 mm.

84 5/8" = 2149.475 mm.

CALIFORNIA

Proposition 65 Warning

Diesel engine exhaust and some of its constituents are known to the State of California to cause cancer, birth defects, and other reproductive harm