

WINGET

OPERATING INSTRUCTIONS & SPARE PARTS LIST

3SH DIESEL DUMPER (CAPACITY 22.5 CWT)

FIRST ISSUED FEBRUARY 1976

**REVISED JUNE 1978 & JUNE
1981**

REPRINTED JULY 2002

**WINGET LIMITED
PO BOX 41
EDGEFOLD INDUSTRIAL ESTATE
PLODDER LANE
BOLTON
LANCS
BL4 OLS
TEL: ++ 44 (0) 1204 854650
FAX: ++ 44 (0) 1204 854663
service@winget.co.uk
parts@winget.co.uk
winget.co.uk**

INTRODUCTION

This Parts & Operators Manual is a re-print of the manual last published in 1981 and contains some amended part numbers.

Health & Safety legislation and working practices applicable to Site Dumpers, both 2 and 4 wheel Drive, Rigid Chassis and Articulated Chassis have changed considerably in the years since this manual was last published and immediately following this Introduction are notes on the Safe Use of Site Dumpers. These notes supersede and replace all previous 'Dumper Safety' notes issued with Winget 3SH Dumpers

Reference is made on a number of pages to 'bolt c/w nut and washer', this no longer the case, fixings such as nuts, bolts, screws and washers should be ordered as individual items. A number of Whitworth and B.S.F fixings are now no longer available, in these cases the nearest metric equivalent size will be supplied.

The contents of this manual although correct at the time of publication, may be subject to alteration by the manufacturers without notice and Winget Limited can accept no responsibility for any errors or omissions contained within the following pages. Nor can we accept any liability whatsoever arising from the use of this manual howsoever caused.

Winget Limited operate a policy of continuous product development. Therefore, some illustrations or text within this publication may differ from your machine.

WINGET LIMITED
PO BOX 41
EDGEFOLD INDUSTRIAL ESTATE
PLODDER LANE
BOLTON
LANCS
BL4 OLS
TEL ++ 44 (0) 1204 854650
FAX ++ 44 (0) 1204 854663
E mail service@winget.co.uk
parts@winget.co.uk
www.winget.co.uk

Safety is the responsibility of all persons working with this machine. Think "safety" at all times. ***Read and remember the contents of this handbook.***

The safe working recommendations for specific tasks are found with the instructions for the relevant operation in this Handbook.

MACHINE MODIFICATION

WARNING Any modifications to the machine will affect its working parameters and safety factors. Refer to the Manufacturers before fitting any non-standard equipment or parts.



The Manufacturers accept no responsibility for any modifications made after the machine has left the factory, unless previously agreed by the Manufacturers in writing; the Manufacturers will accept no liability for damage to property, personnel or the machine if failure is brought about due to such modifications, or fitment of spurious parts.

TRAINING

WARNING Only trained operators should use this machine.



Operators should hold an appropriate full motor vehicle driving licence and undergo both a safety awareness course and a driver training course for Site dumpers run by the C.ITB or equivalent body leading to the award of a CTA.

It is strongly recommended that operators read the H.S.E. publication "Safe Working with Small Dumpers" which is available from government bookshops (HMSO) or from other bookshops quoting the following number ISBN O11 8836935. Another useful publication is British Standard number BS 6264, "Procedure for Operator Training For Earth Moving Machinery" available from the British Standard Institution.

RUNNING-IN

WARNING While a gradual 'running-in' of a new engine is not necessary, it is extremely important that the instructions given in *Section 2 "Operation"* on "Running-in a new engine" should be followed very closely during the first fifty hours of operation.



DRIVING

WARNING ***NEVER*** use the machine for purposes other than those for which it was designed. This machine was designed to carry loads such as soil, clay, sand, wet concrete, stone or other similar materials. It was not designed to carry loads which may move around in the skip uncontrollably, nor to carry any loads or materials which overhang the skip in any way. If in any doubt as to the suitability of this machine for a particular task, contact your nearest Distributor or the Manufacturer for advice.



ALWAYS be aware of local and national regulations governing the use of the machine.

NEVER commence work with the machine until the "Daily (or every ten hours)" service checks have been made. (*See Service Section* for details)

ALWAYS check wheel nut tightness daily.

NEVER carry passengers.

Ensure that the seat is securely fixed to the machine. Where seat belt restraints are fitted as part of Rops/Fops protection they must be worn. Check that the seat belt is in good condition, free from cuts and frayed edges.

ALWAYS remain in the driving seat whenever the engine is running. Never attempt to operate any controls unless seated.

ALWAYS apply the parking brake before leaving the driver's seat.

NEVER dismount with the engine running, and never leave the machine unattended with the key in the starter switch.

When Battery Isolators are fitted they must be activated only when the engine is turned off except in cases of emergency.

Activating a Battery Isolator when the engine is running can result in damage to the electrical components and circuits.

NEVER fill the fuel or hydraulic tanks with the engine running.

ALWAYS drive only on surfaces that are known to be stable.

ALWAYS keep the floor plates and walkways clean.

NEVER drive the machine close to the edge of any excavation. Always use effective wheel stops to prevent the machine running close to the edge. Make sure that the stops are in proportion to the size of the wheels and are set sufficiently far enough back from the edge of any excavation to prevent the weight of the load causing a collapse.

NEVER adjust the tyre pressures in an attempt to improve traction on soft ground or obtain a softer ride on hard ground. Incorrectly adjusted tyres can affect the steering and handling characteristics.

NEVER attempt to free a machine which is 'bogged down' by pushing with the bucket of a backhoe loader, tracked excavator or other similar machine.

NEVER make unnecessary "crash stops" when travelling at speed, especially in forward direction.

NEVER work under an unpropped skip. If the dumper was supplied with a special skip support always ensure that it is used.

SKIPS AND LOADING

WARNING NEVER exceed the rated payload. The weights of all loads above skip water level must be checked.



NEVER remain on the machine when loading the skip with excavators or loaders. Stop the engine, apply the parking brake, dismount, and stand well clear.

ALWAYS ensure that the load is evenly distributed in the skip.

NEVER carry loads or heap materials in such a manner as to affect the forward vision.

ALWAYS take extra care when tipping non free running loads.

NEVER use the skip in a tipped position to bulldoze heaped materials level or to backfill material into excavations.

TOWING

WARNING NEVER attempt to start the engine of a dumper by towing or pushing.



Dumpers are not designed as towing vehicles. However, trailers may be towed provided that:

- 1 The combined weight of the trailer and its load does not exceed the dumper "drawbar pull of 250kg (2500N)" and dumper "drawbar load of 50kg (500N)".
- 2 Trailers may be towed in first gear on level dry ground, provided a purpose made towing pin is used.
- 3 The dumper skip must be loaded with half the rated payload to ensure tyre adhesion when braking.

NEVER tow loads up, down or across gradients.

GRADIENTS

WARNING NEVER operate **Two Wheel Drive rigid chassis dumpers** on any gradients which exceed 10% (1 in 10), or across gradients which exceed 10% (1 in 10).



ALWAYS remember that slippery or loose surface conditions can adversely affect safe machine operation, including braking, particularly on gradients.

ALWAYS choose routes that avoid steep, slippery or loose gradients.

NEVER coast down gradients. Always negotiate gradients in first gear.

ALWAYS drive forwards up gradients when loaded.

ALWAYS reverse down gradients when loaded.

ALWAYS keep the load facing uphill.

NEVER park on a gradient. If this is unavoidable, *ALWAYS* chock the wheels.

NEVER attempt to turn on a gradient

NEVER tow up, down or across a gradient.

NEVER operate high discharge or rotating skips on gradients.

HYDRAULICS

WARNING *ALWAYS* "Dump" residual pressure from the system before leaving the machine or before carrying out any maintenance or adjustments.



If maintenance work requires the skip to be in the raised position, then it must be raised and supported before dumping the pressure.

Dump pressure by switching off the engine, then moving the hydraulic control lever several times in each direction.

NEVER leave the machine unattended with pressure in the system.

ALWAYS purge hydraulic rams before commencing work. With the engine running operate the hydraulic control to fully extend and retract the rams.

ALWAYS practise the greatest cleanliness in maintaining hydraulic components.

SERVICING

WARNING *ALWAYS* report any defect at once, before an accident or consequential damage can occur.



ALWAYS conform to service schedules except where:

- 1 Warning lights or warning indicators call for immediate attention.
- 2 Adverse conditions necessitate more frequent servicing.

ALWAYS wear correctly fitting protective clothing. Loose or baggy clothing can be extremely dangerous when working on running engines or machinery.

ALWAYS, where possible, work on or close to engines or machinery only when they are stopped. If this is not practical, remember to keep tools, test equipment and all parts of your body well away from the moving parts.

ALWAYS "Dump" pressure from the hydraulic system before carrying out any kind of maintenance or adjustment. (**see Service - Hydraulic system**).

ALWAYS avoid contact with exhaust pipes, exhaust manifolds and silencers when the engine is running; these can be very hot.

ALWAYS work out of doors, or in a well-ventilated area.

NEVER run an engine in an enclosed space. Exhaust fumes in enclosed areas can kill.

ALWAYS disconnect battery cables and remove battery before using an external charger, carrying out welding repairs or to prevent unauthorised usage when unattended or during a repair.

NEVER allow unqualified personnel to attempt to repair, remove or replace any part of the machine, or anyone to remove large or heavy components without adequate lifting tackle.

NEVER attempt to modify or repair Rops Frames or Fops Canopies by welding, drilling or any other means. Attempts to do so will invalidate Rops/Fops Certification.

ALWAYS obtain advice before mixing oils; some are incompatible. If in doubt drain and refill.

NEVER allow oils and fuels to come into regular contact with skin. This can lead to serious skin diseases including, medical evidence suggests, skin cancer. *ALWAYS* wear protective gloves when handling oils and fuels whether topping up, draining or refilling. *ALWAYS* wash hands if oils or fuels come into contact with the skin.

Many liquids used in this machine are harmful if taken internally or splashed into the eyes. In the event of accidentally swallowing oils, fuels, anti-freeze, battery acid etc, *DO NOT* encourage vomiting, seek qualified medical assistance immediately.

ALWAYS dispose of waste oils and fuels into waste oil storage tanks. If storage tanks are not available consult your distributor or local authority for addresses of local designated disposal points. It is illegal to dispose of waste oil into drains or water courses or to bury it.

Equipment which includes friction materials will sometimes contain asbestos. When removing friction material dust from components, such as when servicing brakes or clutches, do not blow out with an airline; it could be harmful to inhale the dust. Remove the dust with a vacuum cleaner or wipe clean with a damp rag. Waste should be placed in a sealed container, marked, and disposed of in accordance with local or national regulations.

The accumulated dust found in clutch housings may contain lead/antimony. No food should be eaten at a work place contaminated by this dust. Hands must be washed before eating. Do not blow out dust with an airline.

NEVER work under an unpropped skip. ***If the dumper was supplied with a special Skip Support always ensure that it is used.***

ALWAYS ensure that when using a starting handle that it is clean and in good condition. Keep the engine starting dog and the part of the starting handle that mates with it lightly lubricated (*Refer to the Engine Handbook*).

PREPARATION FOR USE

BEFORE THE DUMPER IS PUT INTO SERVICE ALWAYS CHECK THE FOLLOWING POINTS:—

(See Fig. 1)

1. **Engine**
Check the oil level on the dipstick (A), topping up if necessary to the full mark. See also 'Recommended Lubricating Oils'
2. **Gearbox**
Check the oil level on the dipstick (B), topping up if necessary to the full mark. See also 'Recommended Lubricating Oils'
3. **Drive Axle**
Remove level plug (C) and check that oil is up to bottom of hole. Top up if necessary through filler plug (D). See also 'Recommended Lubricating Oils'
4. **Steering box**
Remove oil level/filler plug (E) (accessible through bracket) and top up if necessary. See also 'Recommended Lubricating Oils'
5. **Fuel Tank**
Remove filler cap (F) and fill with diesel oil until approximately 1" from the top.
NOTE: Never allow fuel level to fall below 2" deep in the bottom of the tank.
6. **Miscellaneous**
Check all wheel nuts for tightness.
Check all nuts and bolts for tightness. Loose nuts and bolts may lead to damage not covered by the Dumper Warranty.
7. **Hydraulic Brake System (if fitted)**
Ensure the brake master cylinder reservoir is full of brake fluid. Top up if necessary to within 1/4" of the top of the reservoir. Use only brake fluid that conforms to SAE. J 1703.
8. **Hydraulic Tank**
Fill the hydraulic tank (G). Before removing the cap, clean the surrounding area, to prevent the possible entry of foreign matter. DO NOT MIX OILS. See also 'Recommended Lubricating Oils'

N.B. For further Lubrication information see Fig. 6 and corresponding text (pages 8 & 9).

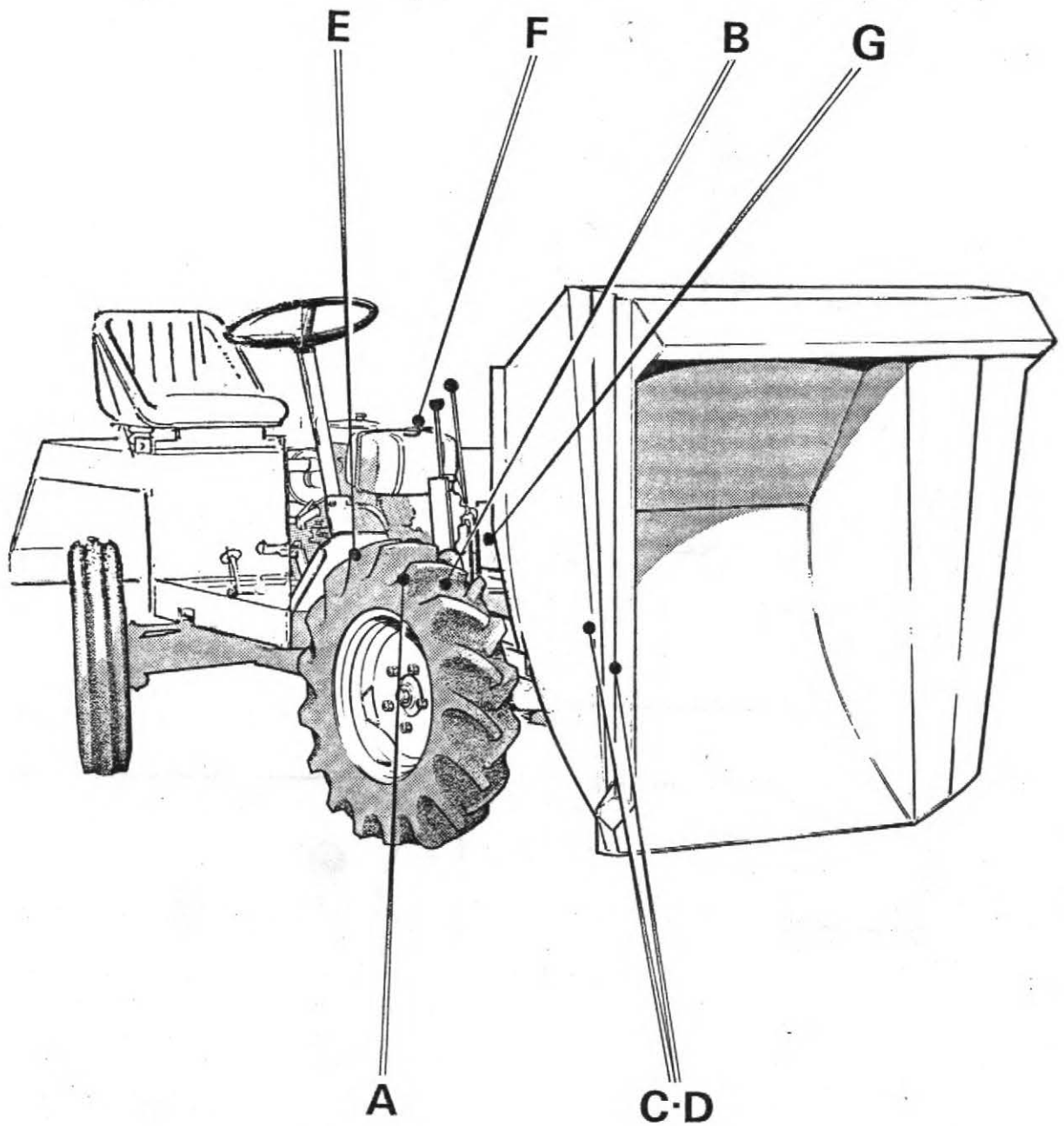

FIG. 1

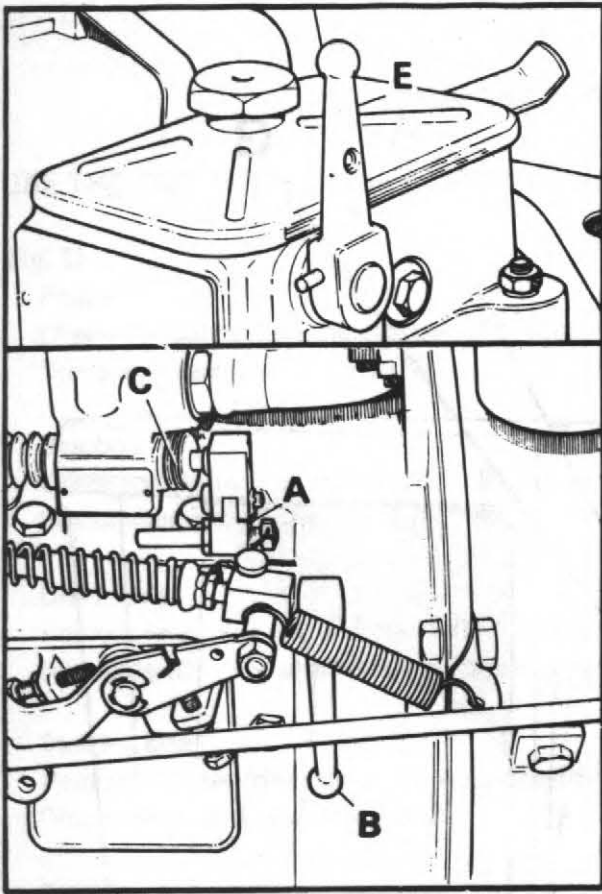

FIG 2

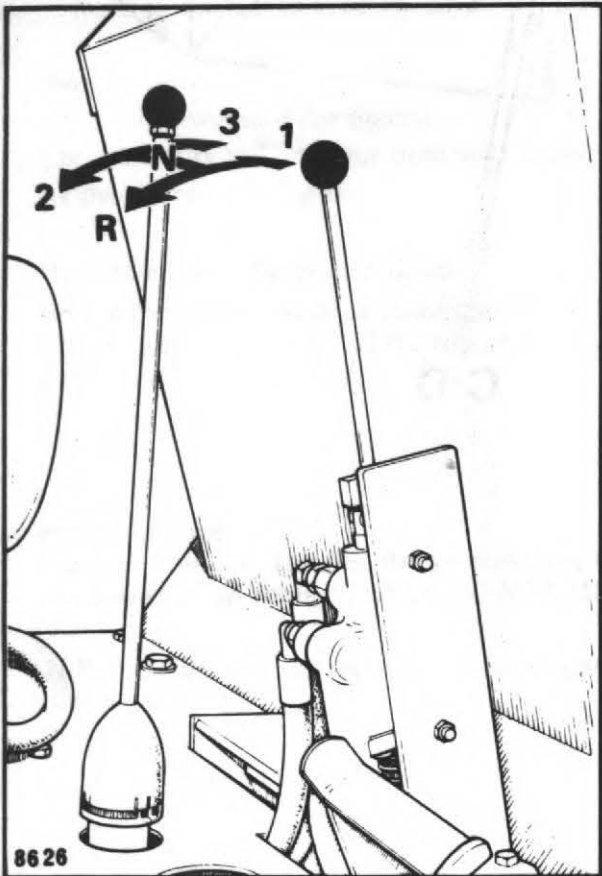

FIG 4

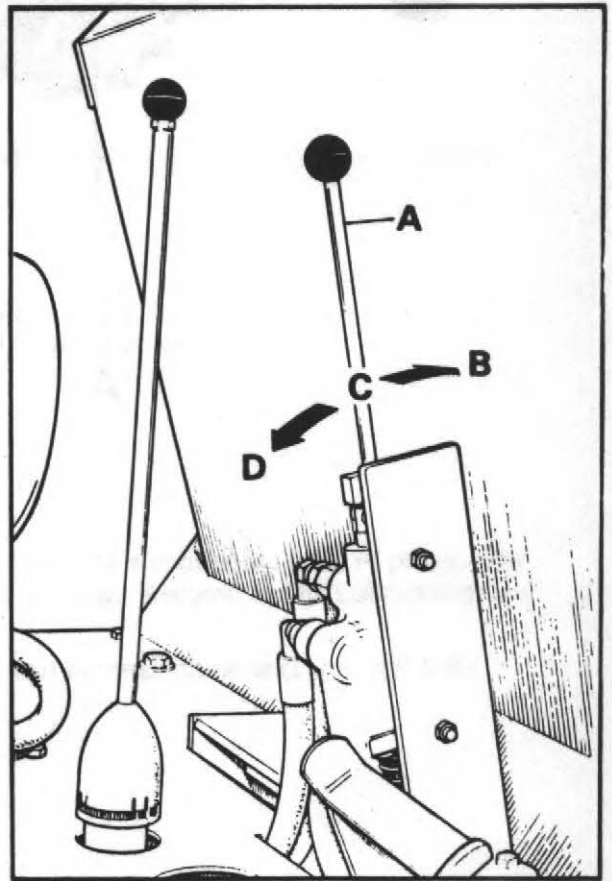

FIG 5

OPERATION

Starting

Fig. 2

1. Lift red-painted overload stop (A) situated on fuel pump immediately above priming lever (B), and move fuel pump racks (C) into fully-open position
2. Operate priming lever (B) six times.

NOTE:- This is unnecessary if engine is already warm.

3. Lift decompression lever (E), positioned on top of engine and turn engine as fast as possible using starting handle. When engine is turning at a good speed knock down decompression lever and engine should fire.
4. If engine does not fire, lift decompression lever and slowly crank engine a few times before attempting to start again. Where ambient temperature is 5°F (-15°C) or below, a cold starting aid should be fitted.

Stopping

Fig. 2

Hold the fuel pump rack (C) in the fully forward position, or lift the priming lever to the horizontal, until engine stops and then release

IMPORTANT:

1. DO NOT stop engine by means of decompression lever, this will lead to damaged valve seats and cylinder head joints.
2. DO NOT stop engine by closing fuel tap or by allowing fuel tank to run dry. This will allow air into fuel lines and necessitate bleeding and priming system.

Gear Shift Lever

Fig. 4

The dumper is fitted with three forward gears and one reverse gear. When changing gear, the clutch pedal is used in the normal manner.

Skip Control Lever

Fig. 5

1. Control lever (A) has three positions, DUMP (B), HOLD (C) and RETURN (D).
2. Push lever forward to DUMP (B) to deposit load.
3. Pull lever back to RETURN (D) to return the skip to the carrying position.

NOTE:- If lever is released when in DUMP or RETURN positions, it will automatically return to HOLD (C) position and motion of skip will cease. In this way, speed at which load is deposited can be finely controlled.

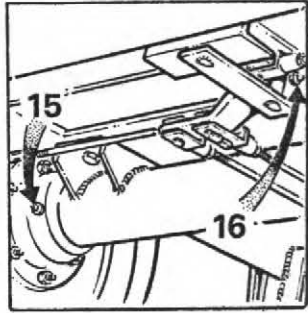
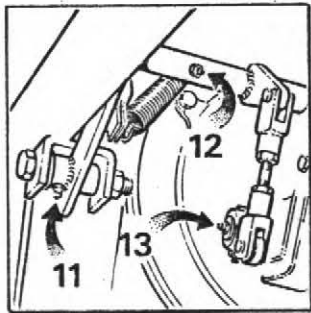
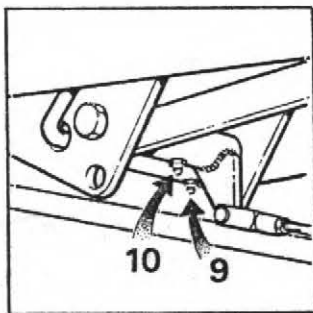
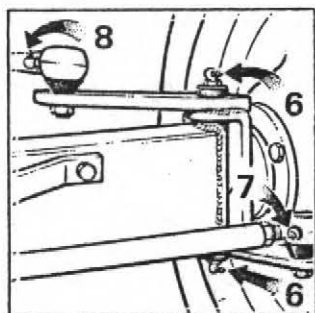
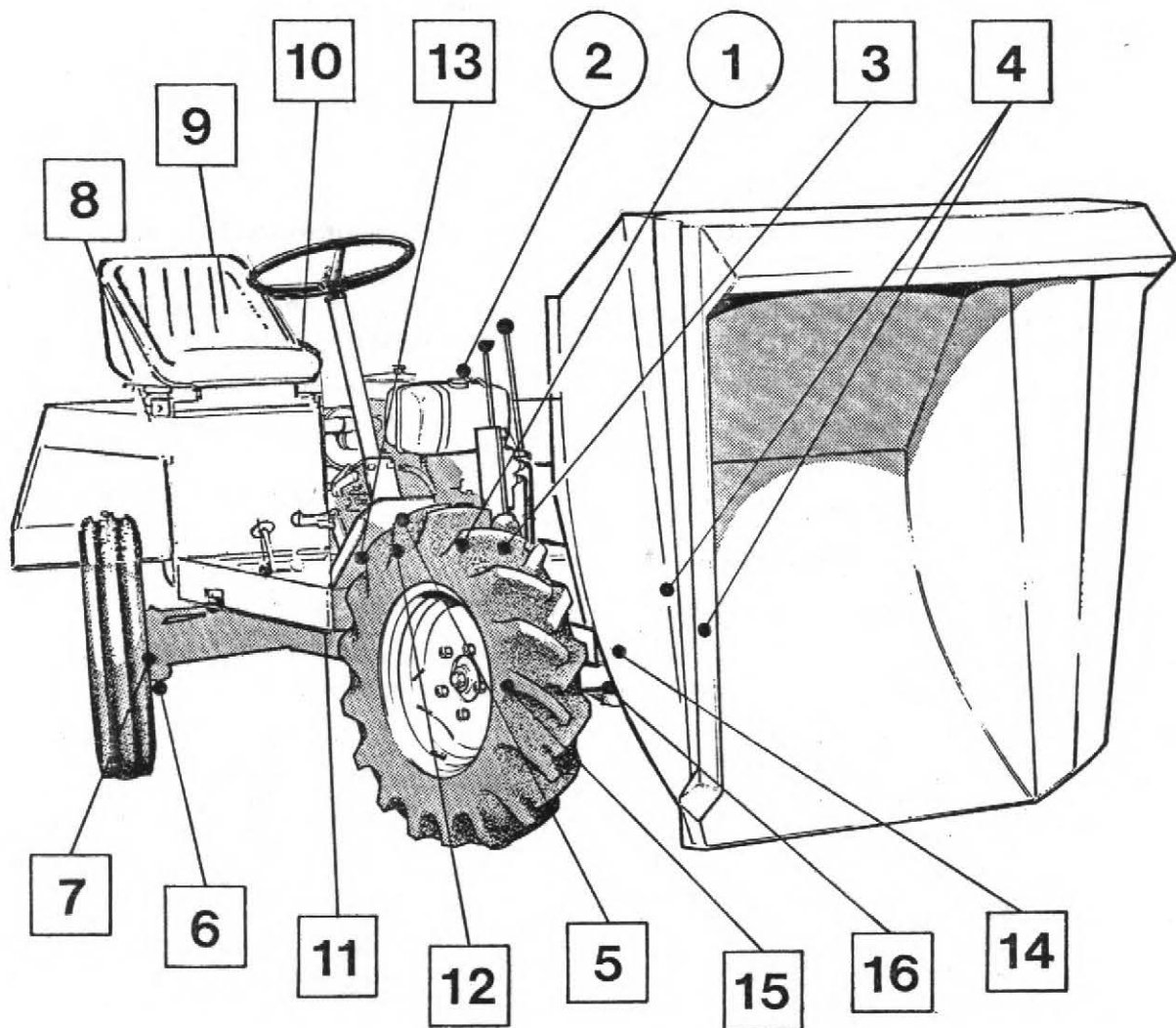
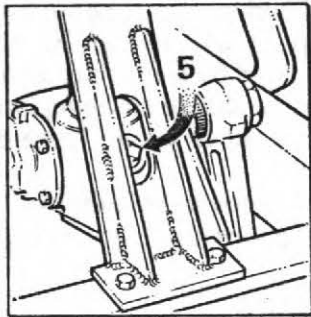
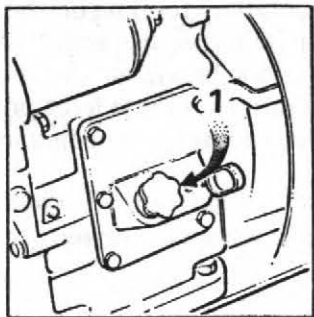
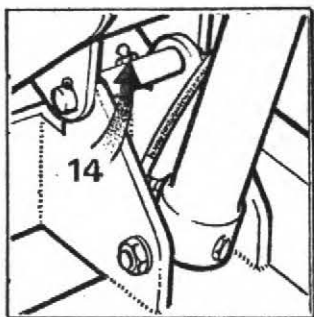

TP 102

FIG 6

Hydraulic Brake System

The brake system is designed to require the minimum of maintenance, and providing the hydraulic fluid in the reservoir is not allowed to fall below the recommended level, no defects should normally occur. Fluid loss must be supplemented by topping up the reservoir with brake fluid that conforms to SAE J 1703. No other fluid may be used. If air is present in the system it will be indicated by sluggish response of the brakes and by spongy action of the brake pedal. This may be due to air being introduced at a loose joint or by the reservoir fluid level being allowed to fall very low. These defects must be remedied immediately and the complete system bled.

To bleed the system, proceed as follows:—

1. Check that all connections are tight and all bleed screws are closed.
2. Fill reservoir with brake fluid.
3. Attach bleeder tube (A) (See fig. 5) to one of the bleed screws (B) and immerse other end in a small quantity of brake fluid contained in a glass jar (C). Slacken bleed screw and operate brake pedal up and down to its full stroke, until fluid pumped into the jar contains no air bubbles. Hold down pedal and close bleed screw. Remove bleeder tube and release pedal.
4. Repeat on the other bleed screw.
5. Continue until all air has been bled from the system.
6. Lock both the bleed screws and top up the reservoir to the correct level.
7. Apply normal working load on brake pedal for two or three minutes and examine the entire system for leaks.

NOTE: DURING THE OPERATION IT IS ESSENTIAL THAT THE RESERVOIR LEVEL IS KEPT TOPPED UP TO PREVENT FURTHER AIR BEING DRAWN INTO THE SYSTEM. ONLY USE NEW FLUID FOR TOPPING UP.

Brake Adjustment (Drum Brakes)

(See fig. 6)

1. Ensure handbrake is fully off.
2. Pull off rubber cover from brake adjuster (A).
3. Screw adjuster clockwise until brakes are fully on.
4. Slacken adjuster anti-clockwise until brake shoes are just clear of drum. This will cause shoes to be centralised on drums and ensure that whole brake lining area is used,

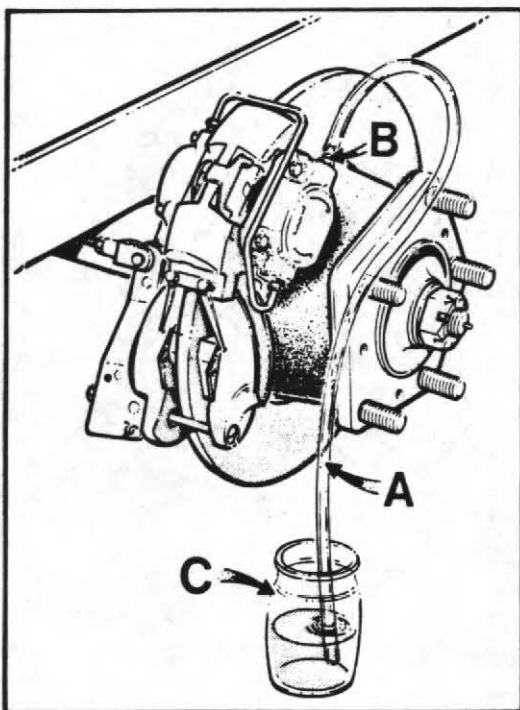

TP 148

FIG. 5

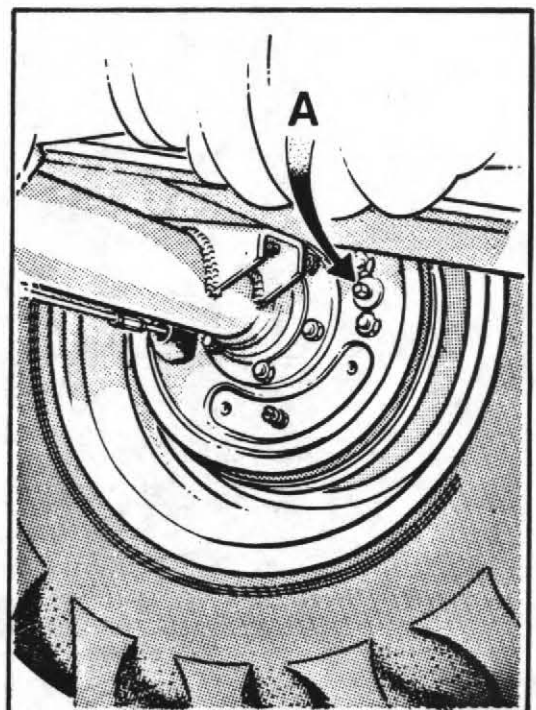

FIG. 6

Main Hydraulic System

The main hydraulic system controls the dumping and return of the skip. If the skip fails to operate or does so extremely slowly, carry out the following procedures until the fault is rectified.

1. Check that hydraulic tank is full of oil.

Fig. 9

2. a) Remove four setscrews (A) securing filler cap assembly (B) and remove assembly.
b) Unscrew suction filter (C) from inside of tank (D) and wash in white spirit. Dry with moisture-free compressed air.
c) Replace suction filter and filler cap assembly.

NOTE:- If suction filter cannot be thoroughly cleaned, fit a new one.

3. Check that hydraulic pressure is correct.
 - a) Fit a 2500 p.s.i. gauge into hydraulic line to base of rams.
 - b) Operate control lever to dump skip and check that pressure reading on gauge is 2000 p.s.i. when ram is fully-extended and relief valve is 'blowing'.

Fig. 10

4. Remove relief valve cartridge (A) (hexagon head) from end of control valve (B) opposite to control lever and replace with a new one.
5. Remove hose adaptor (C) from control valve, remove hexagonal orifice plate (D) and wash in white spirit. Dry using moisture-free compressed air. DO NOT poke wire, etc., into orifice. Re-fit plate and hose adaptor, with slot of orifice plate facing outwards.

If none of these procedures correct the fault, contact your local Winget agent.

Periodically check the hose between the pump and the hydraulic tank to ensure that it is not deformed. Any deformation in the hose may result in a restricted flow and damage to the pump.

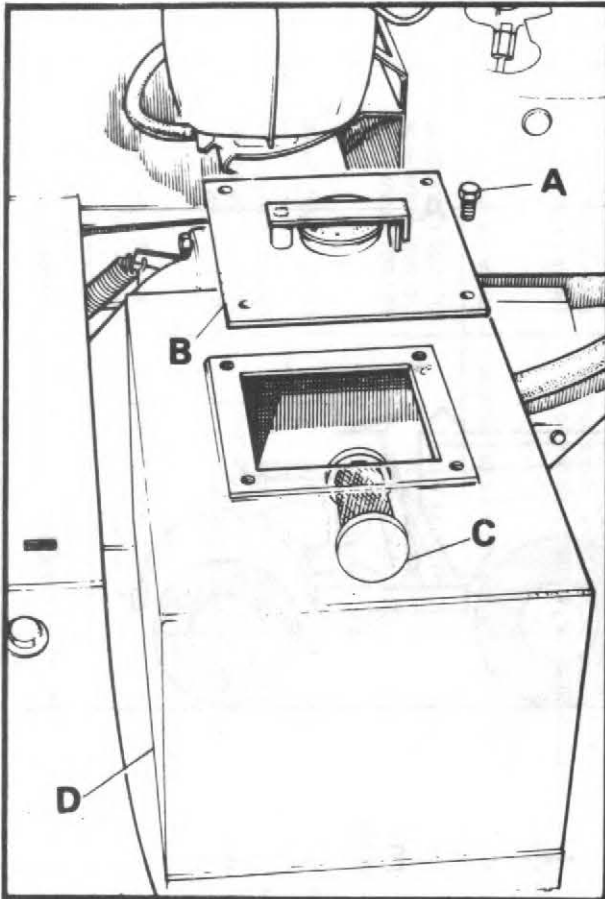

FIG 9

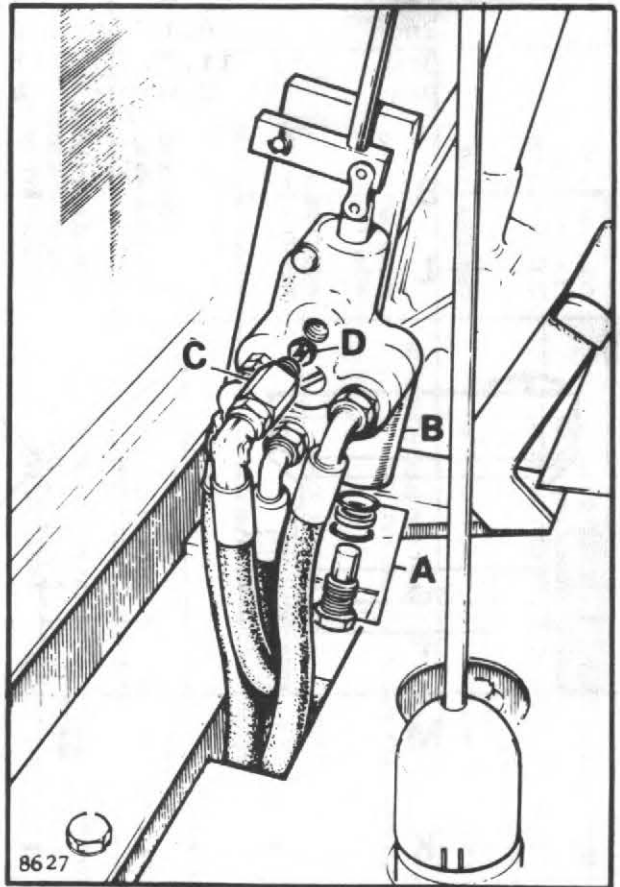

FIG 10

MACHINE SPECIFICATION

Key to Fig. 11

A.	Overall length	9'-1"	(2770 mm)
B.	Overall width	5'-3"	(1600 mm)
C.	Overall height	4'-7"	(1400 mm)
D.	Overall height when tipped	4'-8"	(1420 mm)
E.	Wheelbase	5'-0"	(1525 mm)
F.	Skip loading height	3'-6½"	(1080 mm)
G.	Skip ground clearance when tipped	3"	(75 mm)
H.	Discharge forward of tyre	11"	(280 mm)
J.	Overhang	2'-6"	(760 mm)
K.	Wheeltrack	4'-7"	(1400 mm)
L.	Prow width	3'-4"	(1015 mm)
M.	Ground clearance	10"	(255 mm)

Miscellaneous

Minimum turning circle(kerb to kerb)	22'-9"	(6.9 m)
Unladen weight	2352 lb.	(1068 kg.)
Rear Axle articulation	1ft. 2in.	(35.5 cm.)

Road Speeds

	M.P.H.	K.P.H.
1st	2.6	4.25
2nd	6.1	9.8
3rd	11.3	18.2
Rev.	2.9	4.7

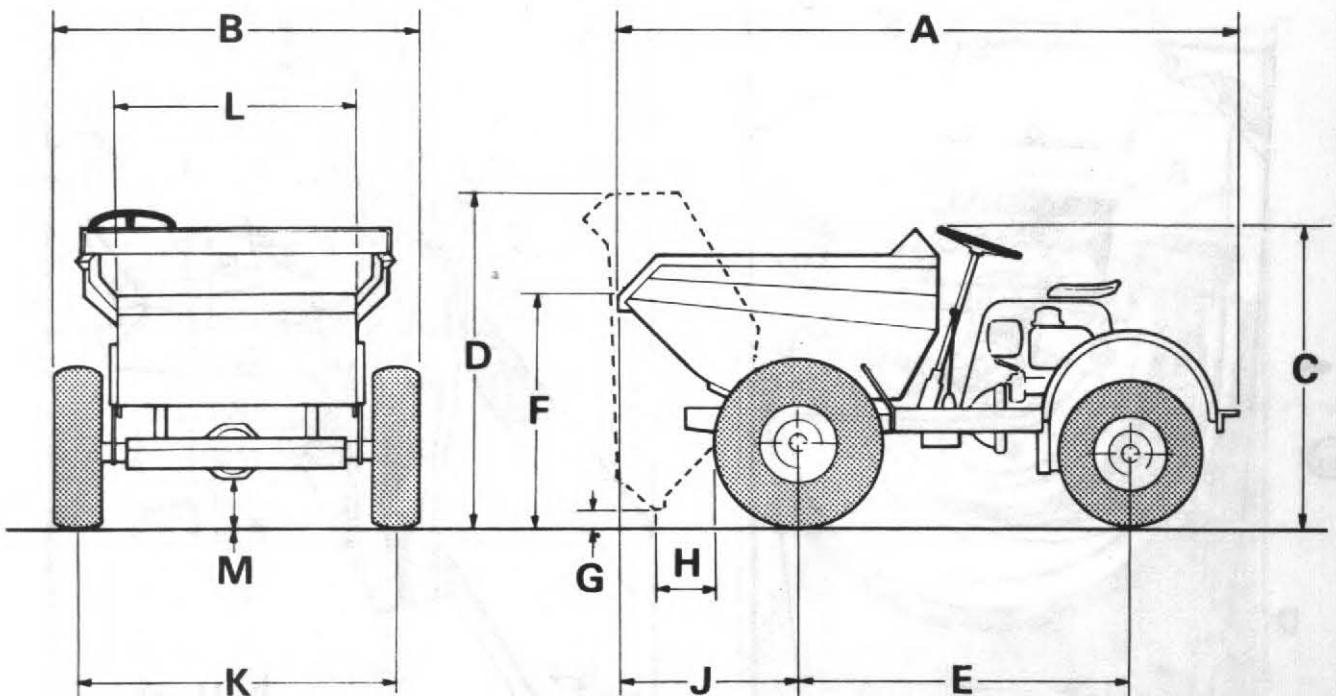

FIG. 11

RECOMMENDED LUBRICATING OILS

COMPANY		ENGINE	TRANSFER BOX & DRIVE AXLE	GEARBOX	WHEEL BEARINGS & OTHER GREASE POINTS	HYDRAULIC SYSTEM
(U.K.) ESSO	SUMMER	ESSOLUBE HDX 20W	GEAR OIL GP 90/140	ESSOLUBE HDX 30	BEACON 2	NUTO H44
	WINTER	ESSOLUBE HDX 30	GEAR OIL GP 140	ESSOLUBE HDX 30	BEACON 2	NUTO H 54 NUTO H 44 NUTO H 40
(Overseas)	ABOVE 32°C 0-32°C BELOW 0°C	ESSOLUBE HDX 20W ESSOLUBE HDX 10W	GEAR OIL GP 90/140 GEAR OIL GP 80			
(U.K.) CASTROL	SUMMER	DEUSOL CRB 20	DEUSOL GEAR EP 90	DEUSOL CRB 30	CASTROL SPHEEROL APT 2	CASTROL HYSPIN AWS 32
	WINTER	DEUSOL CRB 30	DEUSOL GEAR EP 140	DEUSOL CRB 30	CASTROL SPHEEROL APT 2	
(Overseas)	ABOVE 32°C 0-32°C BELOW 0°C	DEUSOL CRB 20 DEUSOL CRB 10	DEUSOL GEAR EP 90 DEUSOL GEAR EP 80			
(U.K.) SHELL	SUMMER	ROTELLA SX QJL 20/20W	SPIRAX 90 EP	ROTELLA SX OIL 30	RETINAX A	TELLUS OIL 27
	WINTER	ROTELLA SX OIL 30	SPIRAX 140 EP	ROTELLA SX OIL 30	RETINAX A	
(Overseas)	ABOVE 32°C 0-32°C BELOW 0°C	ROTELLA SX OIL 20/20W ROTELLA SX OIL 10W	SPIRAX 90 EP SPIRAX 80 EP			
(U.K.) BP	SUMMER	VANELLUS M20W	GEAR OIL SAE 90 EP	VANELLUS M30	ENERGREASE L2	ENERGOL HLP 65
	WINTER	VANELLUS M30	GEAR OIL SAE 140 EP	VANELLUS M30	ENERGREASE L2	
(Overseas)	ABOVE 32°C 0-32°C BELOW 0°C	VANELLUS M20W VANELLUS M10W	GEAR OIL SAE 90 EP GEAR OIL SAE 80 EP			
(U.K.) MOBIL	SUMMER	DELVAC 1220	MOBILUBE HD 90	DELVAC 1230	MOBILGREASE MP MOBILGREASE SUPER	DTE 24
	WINTER	DELVAC 1230	MOBILUBE GX 90			
	ABOVE 32°C	DELVAC 1220	MOBILUBE HD 140			
	0-32°C	DELVAC 1220	MOBILUBE GX 140			
(Overseas)	BELOW 0°C ALL TEMPERATURES	DELVAC 1210 DELVAC SPECIAL 10W-30	MOBILUBE HD 90 MOBILUBE GX 90 MOBILUBE HD 80 MOBILUBE GX 80	DELVAC 1230		
(U.K.) WALKERS CENTURY	SUMMER	CENTLUBE HD 20	CENTURY EP 90	CENTLUBE HD 30	REGULUS A2	CENTURY PWLA HYD OIL
	WINTER	CENTLUBE HD 30	CENTURY EP 140	CENTLUBE HD30	REGULUS A2	CENTURY PWLA HYD OIL
	ABOVE 32°C 0°C-32°C	CENTLUBE HD 20	CENTURY EP 90			
(Overseas)	BELOW 0°C	CENTLUBE HD 10	CENTURY EP 80			

IN THE UNLIKELY EVENT OF THE ABOVE OILS NOT BEING AVAILABLE
EQUIVALENT OILS SUPPLIED BY A REPUTABLE MANUFACTURER MAY BE USED

SPARE PARTS SECTION

LIST OF CONTENTS

Title	Page No.
CHASSIS, MUDWINGS & COVERS	16, 17
SKIP	18
FLYWHEEL & CLUTCH ASSEMBLY	19
GEARBOX	20 - 23
DRIVE AXLE	24 - 27
PROP. SHAFT & COUPLINGS	28
AIR CLEANER	29
DRUM BRAKE ASSEMBLY	30, 31
DRIVE WHEELS & TYRES	32
STEERING WHEELS & TYRES	33
STEERING ASSEMBLY	34, 35
STEERING GEAR (CAM & ROLLER TYPE)	36, 37
STEERING GEAR (RECIRCULATING BALL TYPE)	38, 39
PEDALS & CONTROLS	40, 41
BRAKE PIPES & FITTINGS	42
MASTER CYLINDER	43
BRAKE CALIPER ASSEMBLY	44
HANDBRAKE ASSEMBLY	45
HYDRAULICS	46, 47
PUMP	48, 49
TIPPING CYLINDER	50, 51
HYDRAULIC CONTROL VALVE	52, 53

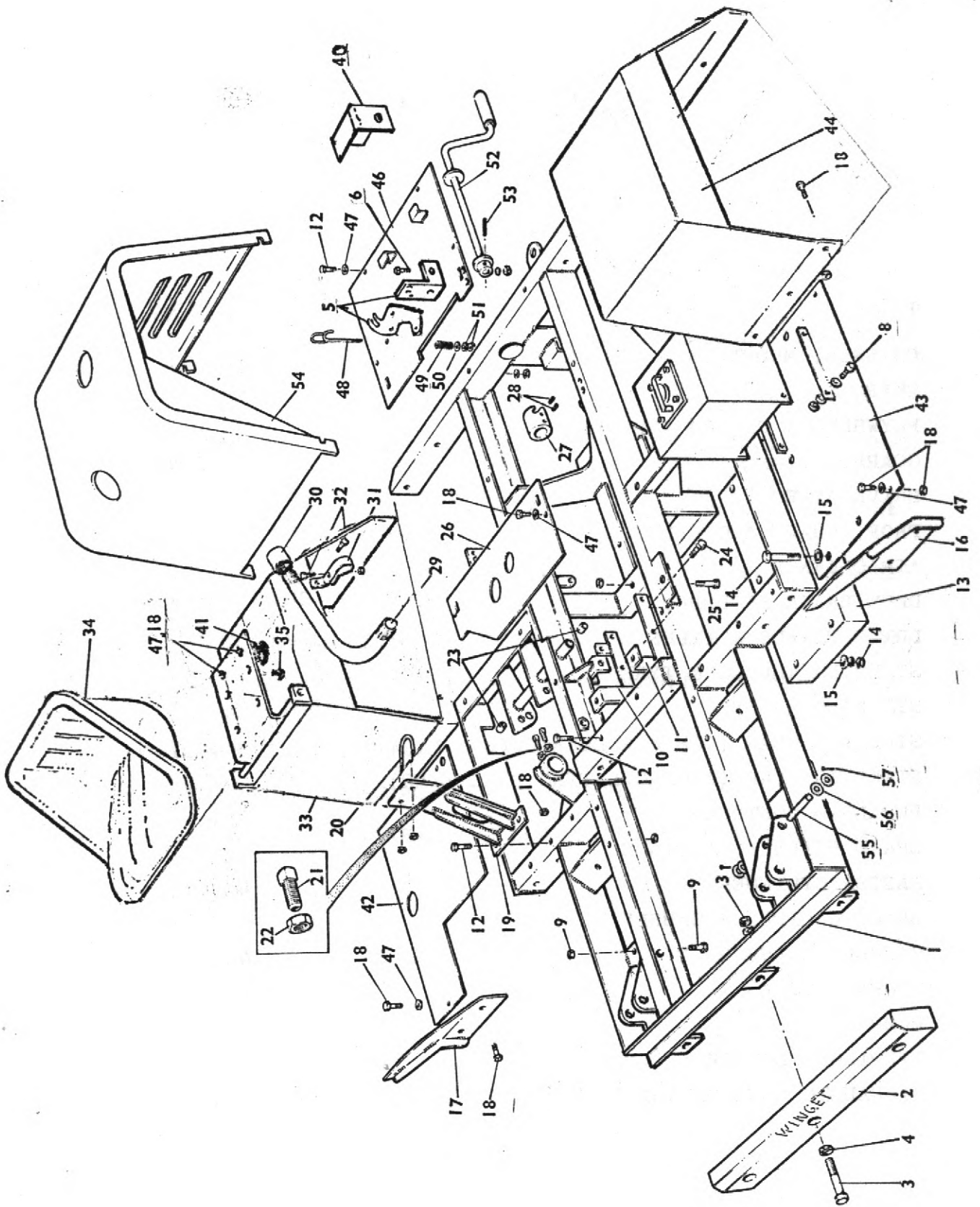

CHASSIS, MUDWINGS & COVERS

Item No.	Part No.	Description	Qty.
1	40177.A01	Chassis	1
2	C-147	Ballast weight	1
3		Bolt 3/4" BSF x 3 1/2" long & Nut	3
4		Flat Washer 3/4" dia	3
5	3SH-80	Pump Bracket	1
6		Bolt M10 x 35mm long & Nut	2
7	2ST-118	Hydraulic Tank	1
8		Bolt M10 x 25 mm long & Nut	4
9		Axle mounting bolt 1/2" BSF x 1 3/4" long & Nut	4
10	L-290	Gearbox support R.H.	1
11	L-290	Gearbox support L.H.	1
12		Bolt M10 x 35mm long & Nut	8
13	L-254	Ballast weight	1
14		Bolt 5/8" whit. x 4 1/2" long & Nut	5
15		Flat washer 5/8" dia.	10
16	L-283	Mudflap L.H.	1
17	L-283	Mudflap R.H.	1
18		Bolt M10 x 25mm long & Nut	2
19	C-117	Steering column support	1
20	C-125	'U' Bolt & Nuts	1
21		Cup point screw M12 x 25mm long	2
22		Locknut M12	2
23	WB0808	Bush	2
24		Bolt 3/8" UNF x 3/4"	4
25		Bolt 1/2" BSF x 2 1/4" long & Nut	4
26	L-284	Gearbox Cover	1
27	L-259	Starter Dog	1
28		Grub Screw 7/16" whit x 1/2" long	2
29	C-165-1	Exhaust Pipe	1
30	C-165-2	Exhaust Socket	1
31	L-315	Exhaust Pipe, Support Brkt.	1
32		Bolt M6 x 16mm long	2
33	40220.A01	Mudwing R.H.	1
34	20072.A01	Seat	1
35		Bolt 5/16 in UNC x 3/4" long	4
40	10592.A02	Hydraulic Pump Drive Guard Assembly	1
41	10519.A01	Rubber Spring	2
42	L-286	Footplate R.H.	1
43	L-285	Footplate L.H.	1
44	40220.A02	Mudwing L.H.	1
46	L-287	Rear Cover	1
47		Flat washer 10mm dia.	12
48	L-287A	Starting handle retaining clip	1
49	L-256C	Spring	1
50		Flat washer 1/4" dia	1
51		Nut 1/4" whit	2
52	L-294	Starting handle	1
53		Tension Pin 3/8" dia x 2 1/4" long	1
54	40232.A02	Engine Cover	1
55	3SH-84	Ram pivot pin	2
56		Flat washer 7/8" dia.	8
57		Split pin 1/8" dia.	4

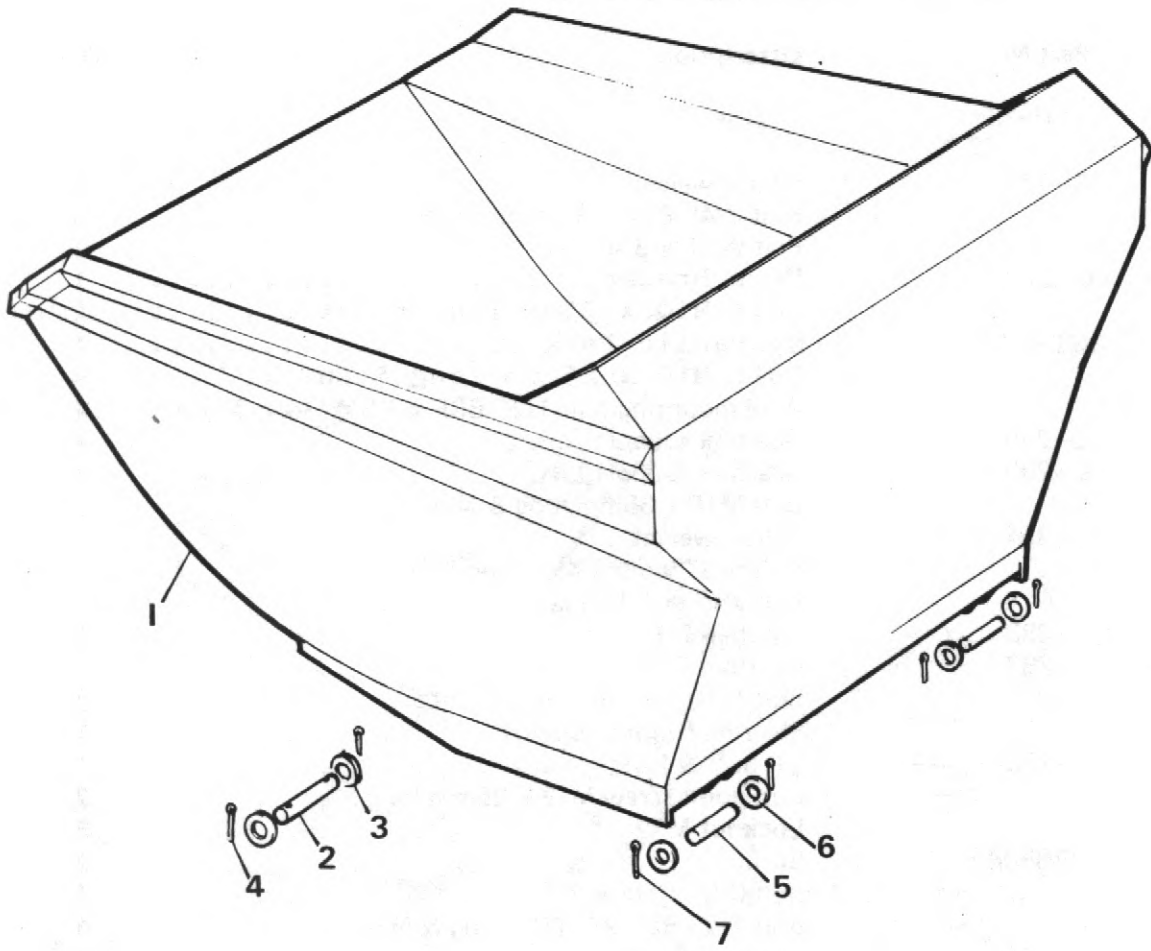

TP165

SKIP & RELEASE LEVER

Item No.	Part No.	Description	Qty
1	3SH-52	Skip	1
2	3SH-65	Skip pivot pin	2
3		Flat washer $\frac{7}{8}$ " dia.	AR
4		Split pin $\frac{3}{16}$ " dia.	4
5	3SH-83	Ram pivot pin	2
6		Flat washer $\frac{5}{8}$ " dia.	4
7		Split pin $\frac{1}{8}$ " dia.	4

FLYWHEEL AND CLUTCH ASSEMBLY

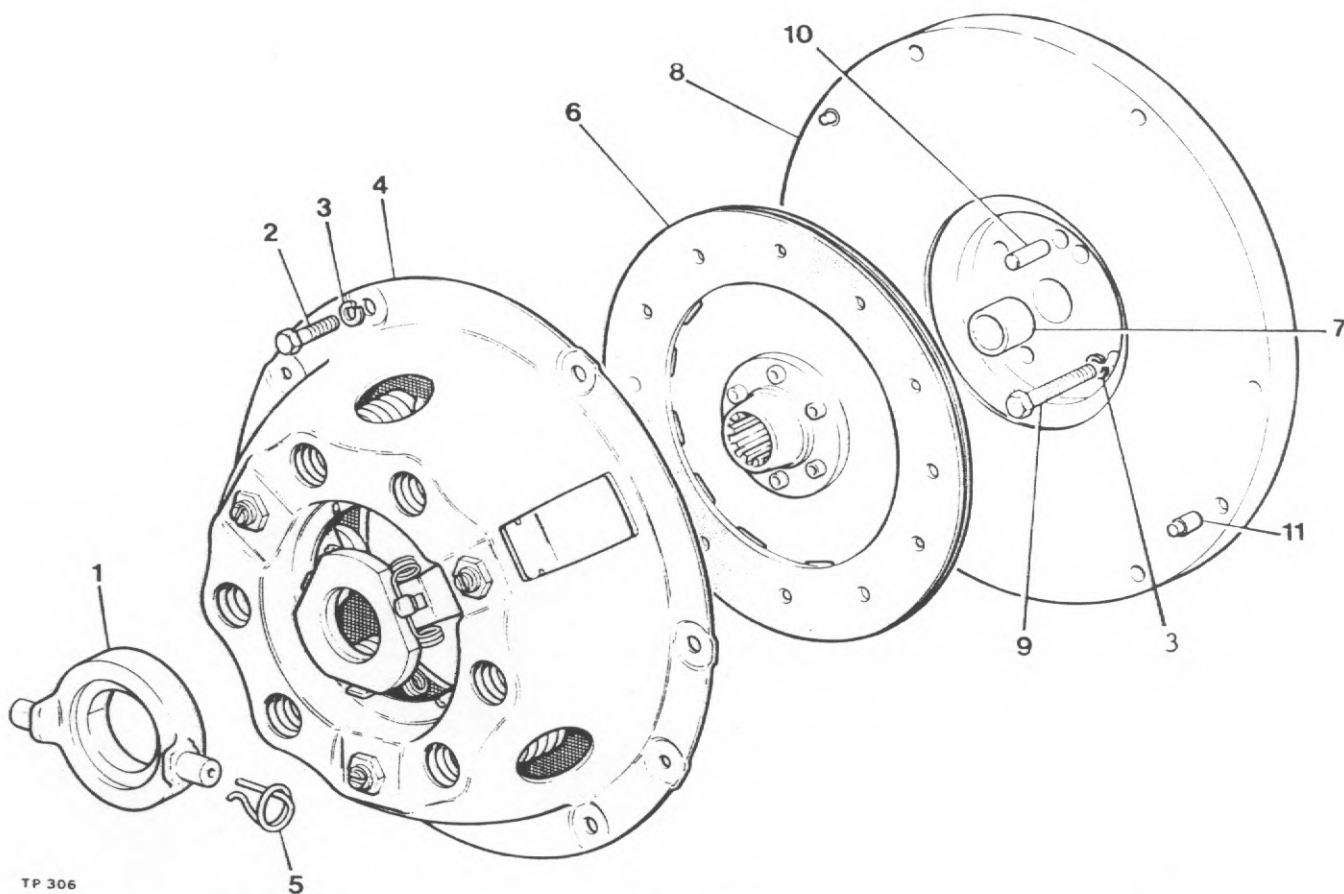

TP 306

Item No.	Part No.	Description	Qty.
1	10579A01	Clutch Release Bearing	1
2	28S02D	Screw Set	6
3	41S04	Washer Spring	10
4	10597A01	Cover Assembly	1
5	10579A101	Retainer Spring	2
6	10598A02	Drive Plate	1
7	10580A0101	Bush	1
8	10580A02	Flywheel Assembly (comprises of items 7, 8, & 11)	1
9	1S02C	Bolt, Petter PH Engine (drill for locking wire)	4
9A	6S02B	Bolt, Lister Engine (drill for locking wire)	4
10	C321	Dowel	1
11	10580A0102	Dowel	2
	10948A02	Clutch Kit (comprises of items 1, 4, 5 & 6)	1

It is recommended that instead of drilling the head of the bolts (item 9) for locking wire that one of each of tabwashers part no's 10531A02 and 10531A03 are used to prevent the bolts working loose.

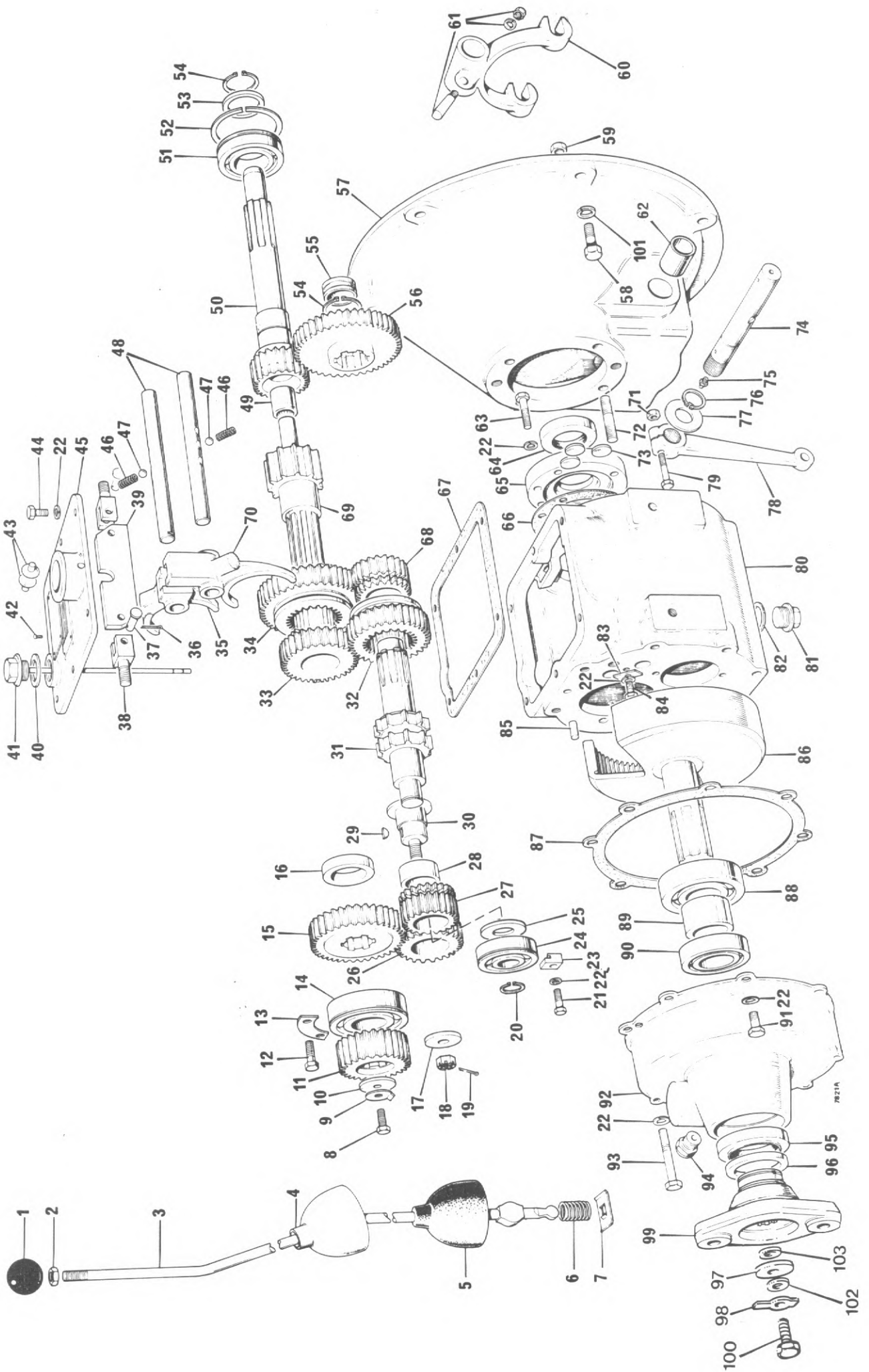

GEARBOX 40M/42 - NEWAGE 30106.A01

Item No.	Part No.	Description	Qty.
1	30101.A0201	Knob	1
2	95S .03	Locknut - Gear Lever	1
3	30101.A0202	Gear Lever,	1
4	30101.A0203	Cap - Gear Lever	1
5	30101.A0204	Cover - Gear Lever	1
6	30101.A0205	Spring - Gear Lever	1
7	30101.A0206	Retaining Plate - Gear Lever	1
8	28S.03E	Screw - Mainshaft	1
9	30190.A0101	Lock Washer - Tab	1
10	30190.A0102	Washer - Reduction Pinion	1
11	30190.A0103	Reduction Pinion	1
12	28S.01B	Screw - Bearing Retainers	2
13	30190.A0104	Bearing Retainer - Small	1
14	30101.A0210	Bearing - Mainshaft Rear	1
15	30101.A0211	Output Gear	1
16	30101.A0212	Spacer - Output Gear	1
17	30101.A0213	Washer - Reverse Pinion Gear	1
18	102S .04	Nut - Reverse Spindle	1
19	44S .02C	Split Pin	1
20	30101.A0215	Circlip	1
21	28S.01D	Screw	2
22	67S.01	Washer	A/R
23	30190.A0105	Clip, Layshaft Bearing	2
24	30101.A0216	Layshaft Bearing	1
25	30101.A0217	Bearing Spacer	1
26	30101.A0218	Reverse Pinion	1
27	30101.A0219	Reverse Speed Gear	1
28	30101.A0220	Bush - Reverse Pinion	1
29	30101.A0221	Key, Reverse Pinion Shaft	1
30	30101.A0222	Shaft, - Reverse Pinion	1
31	30101.A0223	Layshaft	1
32	30101.A0224	2nd Speed Sliding Gear	1
33	30101.A0225	2nd Speed Gear	1
34	30101.A0226	1st Speed Gear	1
35	30101.A0227	Selector Fork 2nd & 3rd	1
36	44S.01C	Split Pin, Interlock	2
37	30101.A0228	Clevis Pin, Interlock	2
38	30101.A0229	Stud, Interlock	2
39	30101.A0230	Interlock Plate	1
40	42S .05	Seal, Dipstick	1
41	30101.A0232	Dipstick	1
42	30101.A0233	Drive Screw	4
43	30101.A0234	Pad - Gear Lever	2
44	28S.01C	Screw - Top Cover	6
45	30101.A0235	Top Cover	1
46	30097.A0185	Detent Spring	2
47	30101.A0236	Detent Ball	2
48	30101.A0237	Selector Shaft	2
49	30101.A0238	Bearing, Primary Shaft	1
50	30101.A0239	Primary Shaft	1

IMPORTANT: With effect from G/Box Batch No.B 1238 the following changes will take place:-

Item	Old Part No.	Description	New Part No.
41	30101.A0232	Dipstick	30218.A0223
31	30101.A0223	Layshaft	30101.A0266
55	30101.A0244	Bearing - Layshaft	30101.A0267

The layshaft will only be supplied complete with bearing as a replacement under part no. 30101.A0268 and will be totally interchangeable with current layshaft. (New Oil Capacity now 2 Litres previously .85 Litres)

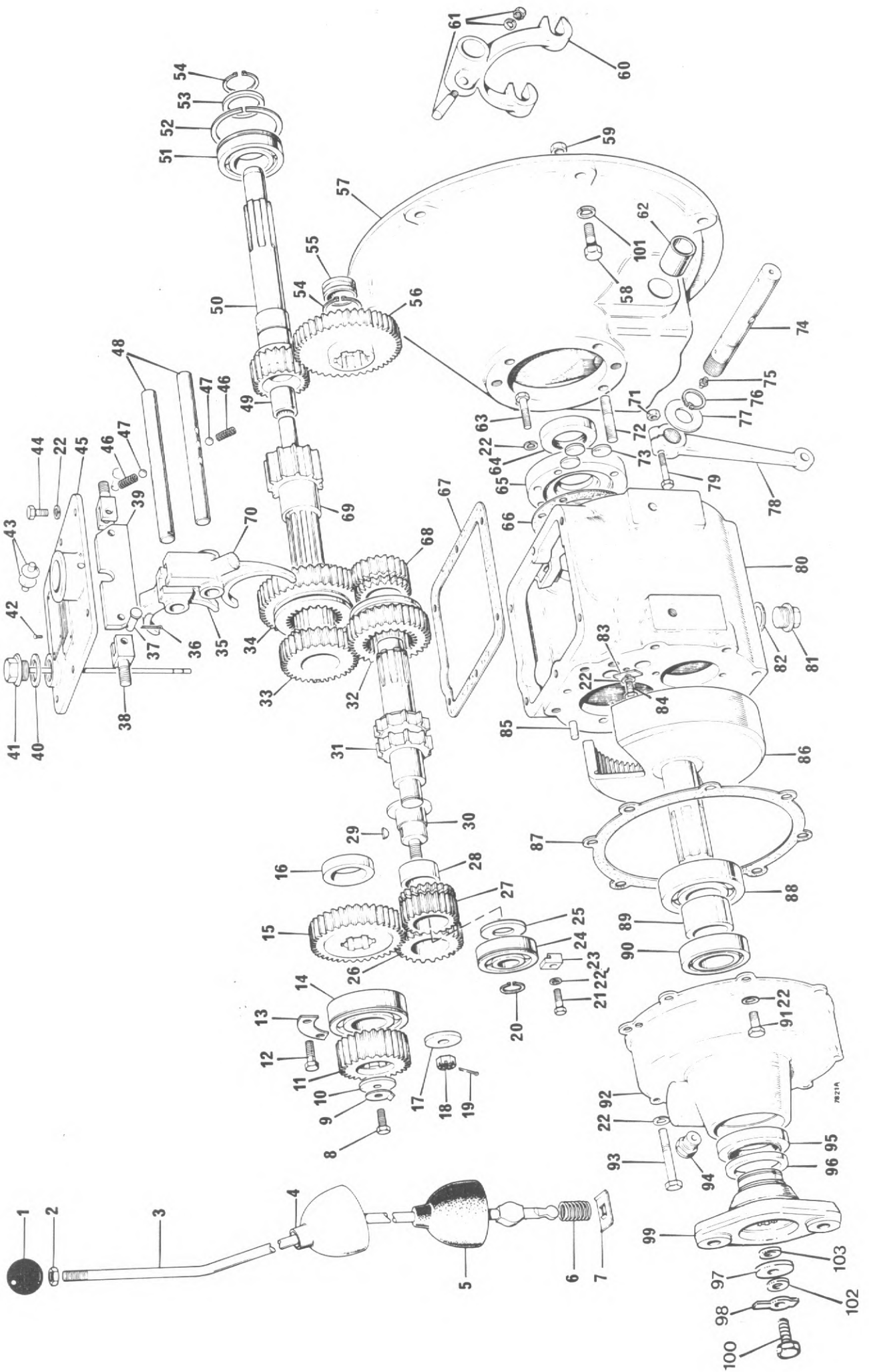

GEARBOX 40M/42 - NEWAGE 30106.A01

Item No.	Part No.	Description	Qty.
51	30101.A0240	Input Bearing	1
52	30101.A0241	Snap Ring	1
53	30101.A0242	Bearing Spacer	1
54	30101.A0243	Circlip	2
55	30101.A0244	Bush - Layshaft	1
56	30101.A0245	1st Reduction Gear	1
57	30101.A0246	Clutch Housing	1
58	3S.03E	Bolt - 3/8" B.S.F. x 1" (Petter) (G/Box - Eng.).	8
	69S.03E	Bolt - 3/8" U.N.C. x 1" (Lister) (" " ").	8
59	9S.03	Nut 3/8" U.N.F.	6
60	30097.A0110	Clutch Release Fork	1
61	30097.A0111	Cotter, Nut & Washer S/A	1
62	30097.A0114	Bush, Cross Shaft	2
63	6S.01B	Bolt, Front Cover	4
64	30101.A0247	Oil Seal - Input	1
65	30101.A0248	Front Cover	1
66	30101.A0249	Joint, Front Cover	1
67	30101.A0250	Joint, Top Cover	1
68	30101.A0219	Reverse Speed Gear	1
69	30190.A0106	Mainshaft	1
70	30101.A0252	Selector Fork 1st & Rev	1
71	9S.01	Nut, Clutch Lever	1
72	30101.A0253	Stud, Clutch Housing	6
73	30101.A0254	Sealing Disc, Selector Shaft	3
74	30101.A0255	Clutch Cross Shaft	1
75	30103.A0102	Grease Nipple	2
76	30101.A0256	Circlip	1
77	30097.A0133	Washer - Cross Shaft	1
78	30097.A0109	Clutch Release Lever	1
79	6S.01C	Bolt - Clutch Lever	1
80	30101.A0262	Casing	1
81	30190.A0108	Drain Plug	1
82	42S.05	Seal, Drain Plug	1
83	30101.A0259	Selector Locking Strip	1
84	28S.01C	Setscrew	2
85	30097.A0155	Dowel	2
86	30190.A0110	Internal Gear	1
87	30190.A0112	Joint - Reduction Housing	1
88	30190.A0111	Bearing - Internal Gear Front	1
89	30101.A0260	Spacer	1
90	30190.A0113	Bearing - Internal Gear Rear	1
91	28S.02D	Screw - Hex. Hd.	5
92	30190.A0114	Reduction - Housing	1
93	6S.02J	Bolt - Hex. Hd.	1
94	30097.A0171	Breather	1
95	30097.A0132	Oil Seal - Rear	1
96	30101.A0265	Dust Shield	1
97	30101.A0208	Washer - Coupling	1
98	30101.A0207	Lock Wash 	1
99	30105.A0102	Coupling	1
100	28S.05E	Screw - Coupling	1
101	41S.05	Spring Washer	8
102	30143.A0111	Fibre Washer	1
103	30143.A0101	Fibre Washer	1

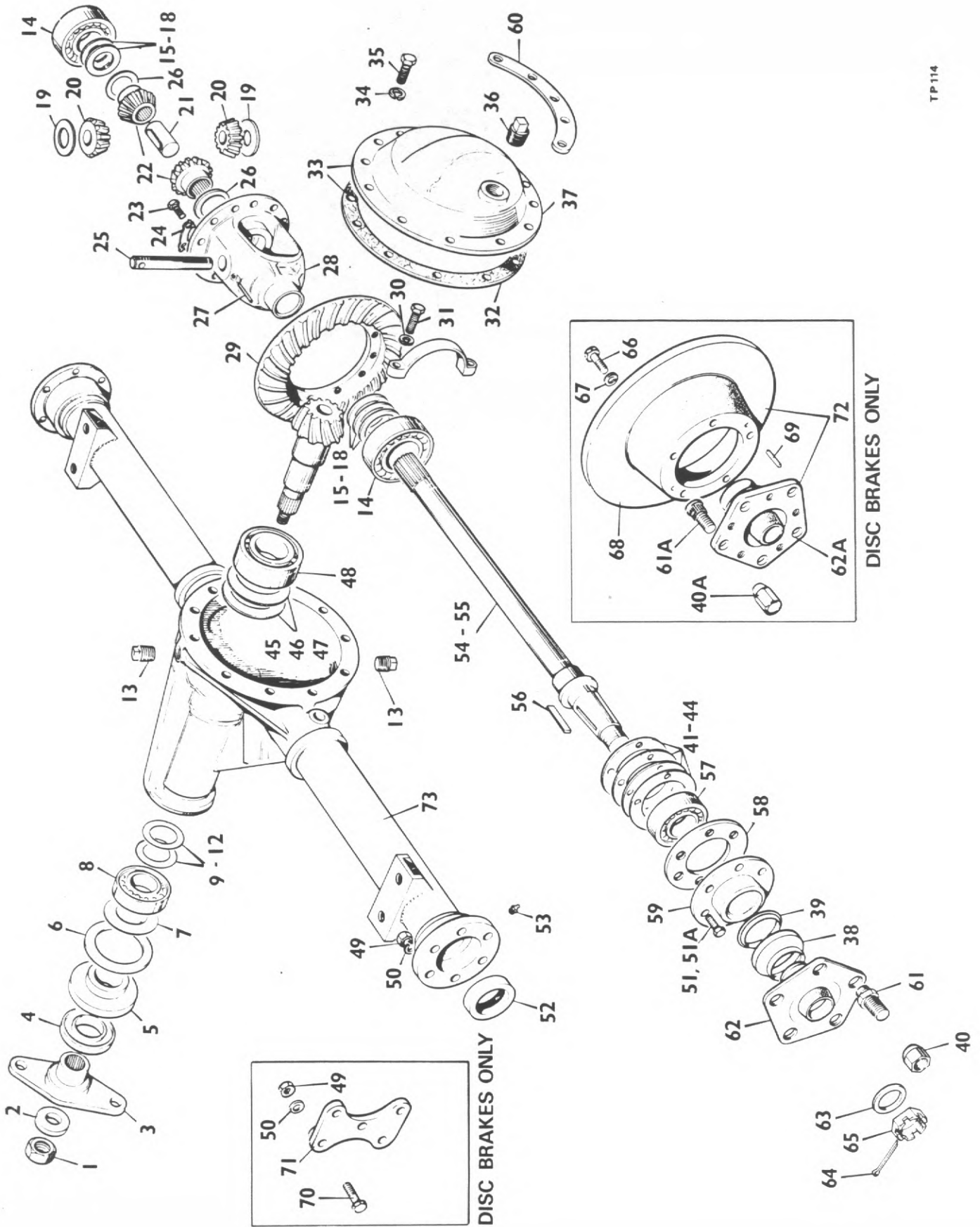

DRIVE AXLE

Item No.	Part No.	Description	Qty.
	5HA-001-274	Drive Axle Complete with drum brakes (1 per m/c)	
	5HA-001-174	Drive Axle Complete with disc brakes (1 per m/c)	
1	12 LN-NF9B	Pinion Nut	1
2	12W-24	Pinion Nut Washer 3/4" dia std. heavy pattern	1
3	3HA-102-10	Companion Flange Assembly	1
4	2HA-021	Companion Flange Dust Shield	1
5	8HA-019-3	Pinion Oil Seal	1
6	2HA-020	Pinion Oil Seal Gasket	1
7	2HA-036	Pinion Oil Slinger	1
8	5HA-022	Pinion Bearing, Outer	1
9	5HA-039	Pinion Bearing Adjusting Shim Outer .003"	A/R
10	5HA-040	Pinion Bearing Adjusting Shim Outer .005"	A/R
11	5HA-041	Pinion Bearing Adjusting Shim Outer .010"	A/R
12	5HA-042	Pinion Bearing Adjusting Shim Outer .030"	A/R
13	HA-059	Filler and Drain Plug (each)	1
14	5HA-024/1	Differential Bearing	2
15	5HA-046	Differential Bearing Shim .003"	A/R
16	5HA-047	Differential Bearing Shim .005"	A/R
17	5HA-048	Differential Bearing Shim .010"	A/R
18	5HA-049	Differential Bearing Shim .030"	A/R
19	5HA-037	Differential Pinion Mate Thrustwasher	2
20	5HA-008-1	Differential Pinion Mate	2
21	5HA-033-3	Axle Shaft Spacer	1
22	5HA-007-2	Differential Side Gear	2
23	5HA-075-2	Drive Gear Screw	12
24	5HA-074-1	Drive Gear Tabwasher	6
25	5HA-012	Differential Pinion Mate Shaft	1
26	5HA-038	Differential Side Gear Thrustwasher	2
27	5HA-013	Differential Pinion Mate Shaft Lock Pin	1
28	5HA-006	Differential Case	1
29	5HA-105 15	Drive Gear and Pinion Assembly Complete	1
30	8 LW-115	Differential Bearing Cap Springwasher 1/2" dia	4
31	8 B-NC-36	Differential Bearing Cap Bolt	4
32	5HA-026	Gear Carrier Cover Gasket	1
33	5HA-064-17	Gear Carrier Cover Assembly	1
34	6LW-105	Cover Screw Springwasher	10
35	6B-NC10	Cover Screw	10
36	HA-059	Level Plug	1
37	5HA-064-1	Gear Carrier Cover	1
38	5HA-030-4	Shroud	2
39	5HA-032-14	Seal	2
40	C 177	Wheel Nut (Drum brakes only)	10
40A	R340	Wheel Nut (Disc brakes only)	10
41	5HA-050-3	Axle Shaft Bearing Shim .003"	A/R
42	5HA-051-3	Axle Shaft Bearing Shim .005"	A/R
43	5HA-052-3	Axle Shaft Bearing Shim .010"	A/R
44	5HA-053-3	Axle Shaft Bearing Shim .030"	A/R
45	5HA-043	Pinion Adjusting Shim, Inner .003"	A/R
46	5HA-044	Pinion Adjusting Shim, Inner .005"	A/R
47	5HA-045	Pinion Adjusting Shim, Inner .010"	A/R
48	5HA-023	Pinion Bearing Inner	1
49	6N-NF5	Bearing Retainer Nut 3/8" UNF	12
50	6W-12	Spring Washer	12
51	6B-NF 18/B	Bearing retainer bolt (drum brakes only)	12
51A	6B NF 21	Bearing retainer bolt (disc brakes only)	6
52	5HA-027	Axle Shaft Oil Seal	2
53	5HA-056-1	Axle Shaft Bearing Grease Nipple	2
54	5HA-005-51	Axle Shaft RH. (complete with Nut)	1
55	5HA-005-51	Axle Shaft LH. (complete with Nut)	1
56	5HA-029	Axle Shaft Key	2
57	5HA-025	Axle Shaft Bearing	2
58	5HA-035-5	Axle Shaft Bearing Retainer	2
59	5HA-057-3	Hub oil seal assembly	2
60	4-35-235	Differential cover support	1

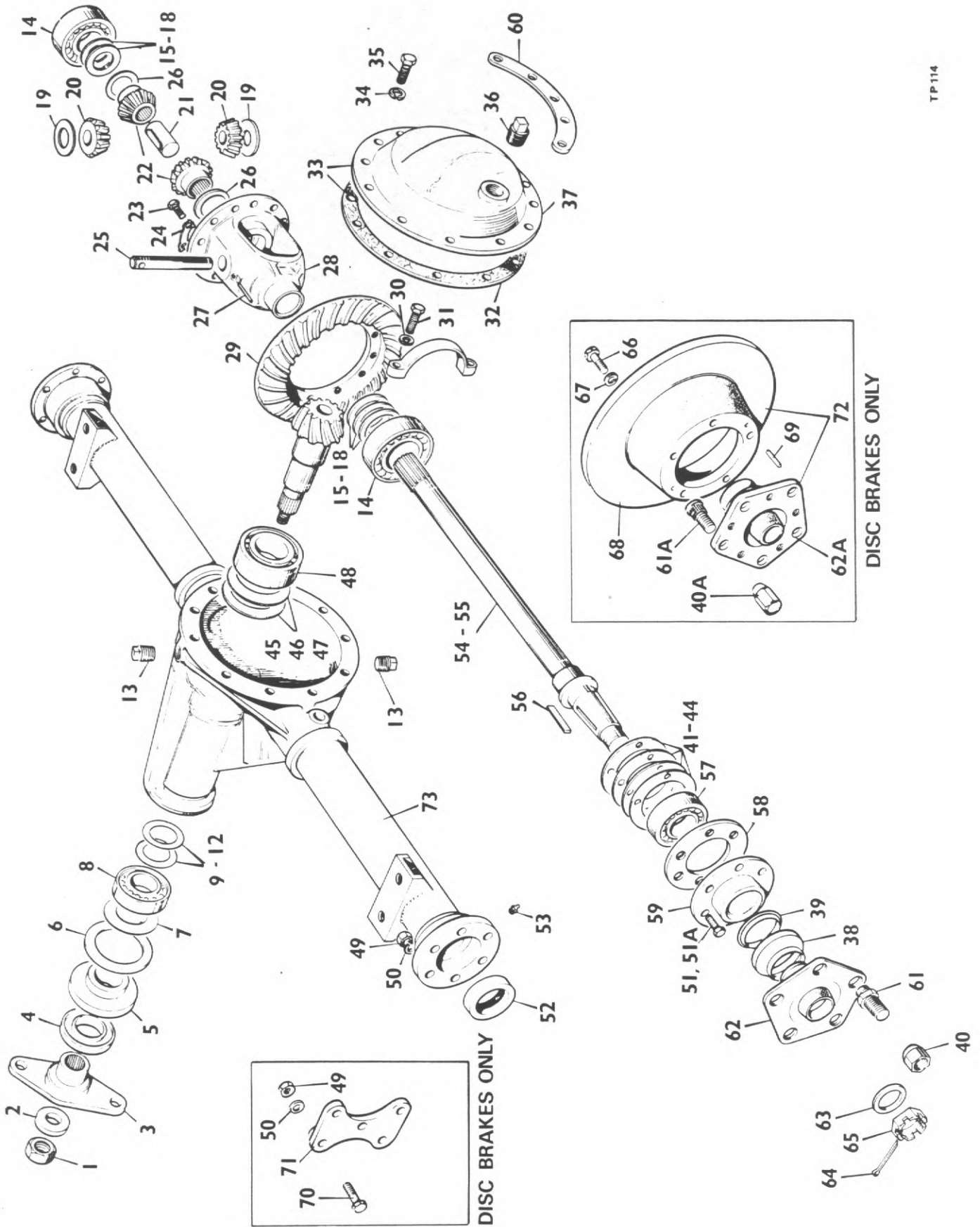

DRIVE AXLE (Cont'd.)

Item No.	Part No.	Description	Qty.
61	5HA-055-6	Wheel stud (drum brakes only)	10
61A	5HA-055-17	Wheel stud (disc brakes only)	10
62	5HA-028-37	Wheel hub complete	2
62A	5HA-028-56	Wheel hub c/w studs (Disc brakes only)	2
63	18W-32	Axle shaft washer	2
64	12SP-18	Axle shaft cotter 3/16" x 2"	2
65	18-SN-NF-12	Axle shaft Nut	2
66	6B-NF-21	Brake disc bolt (disc brakes only)	10
67	6LW-105	Brake disc bolt lockwasher (disc brakes only)	10
68	10HA-136	Brake disc (disc brakes only)	2
69	6D-16	Brake disc dowel (disc brakes only)	4
70	6B-NF24A	Caliper bracket bolt (disc brakes only)	6
71	5HA-137	Caliper bracket (disc brakes only)	2
72	5HA-028-52	Hub & Disc Assembly (disc brakes only)	2
	5HA-082-5	Differential case Assembly (comprising items 19, 20, 21, 22, 25, 26, 27 & 28)	
73	5HA-101-73	Service Carrier & Tube Assembly	1

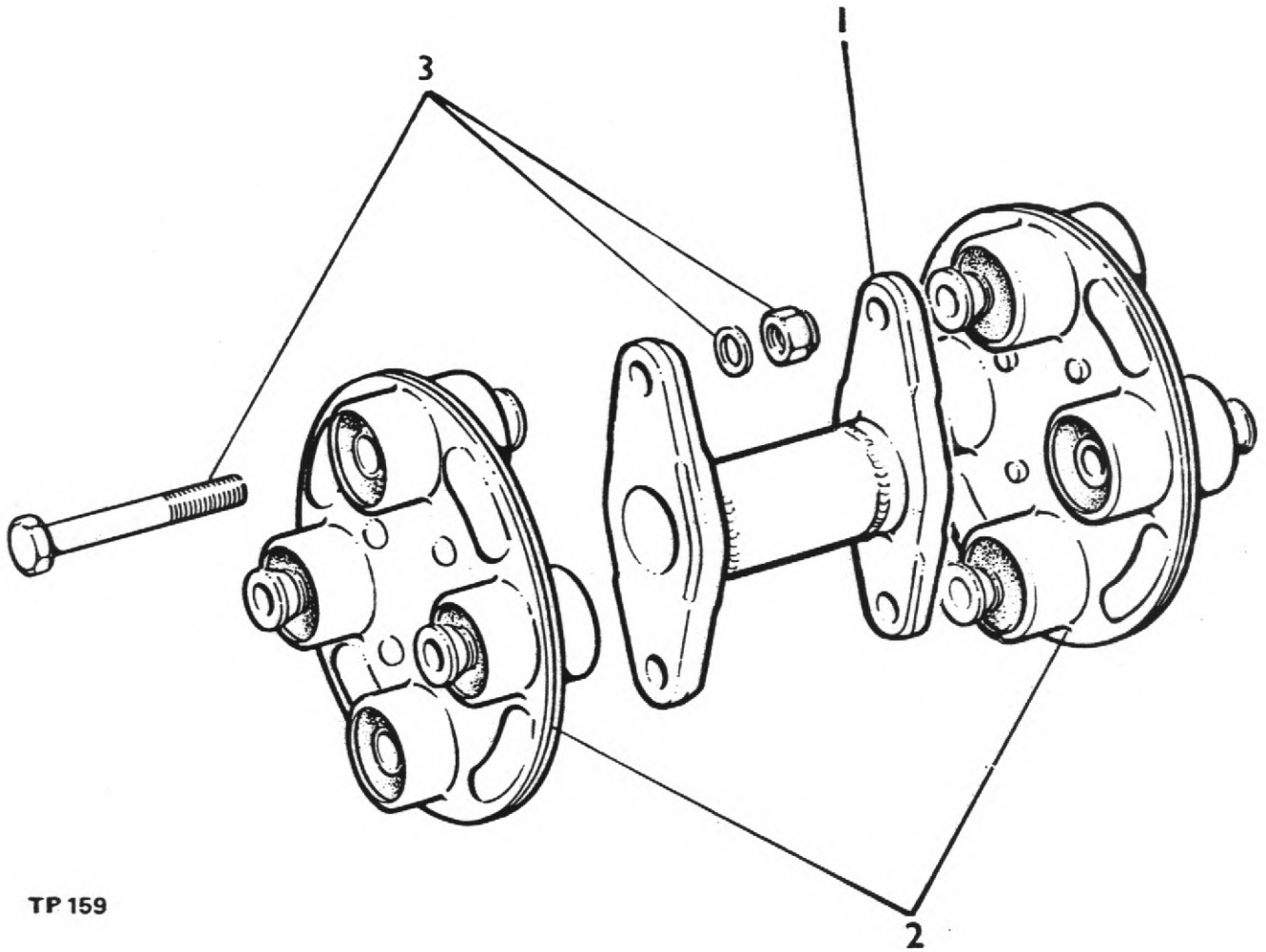

TP 159

PROPSHAFT

Item No.	Part No.	Description	Qty.
1	76491	Prop shaft assembly complete	1
1	L307	Prop shaft tube	1
2	10325A01	Coupling	2
3	10326A01	Coupling bolt, washer and nut	8

Item 3 consists of bolt 8S05L, flat washer 267S19 and binx nut 61S05

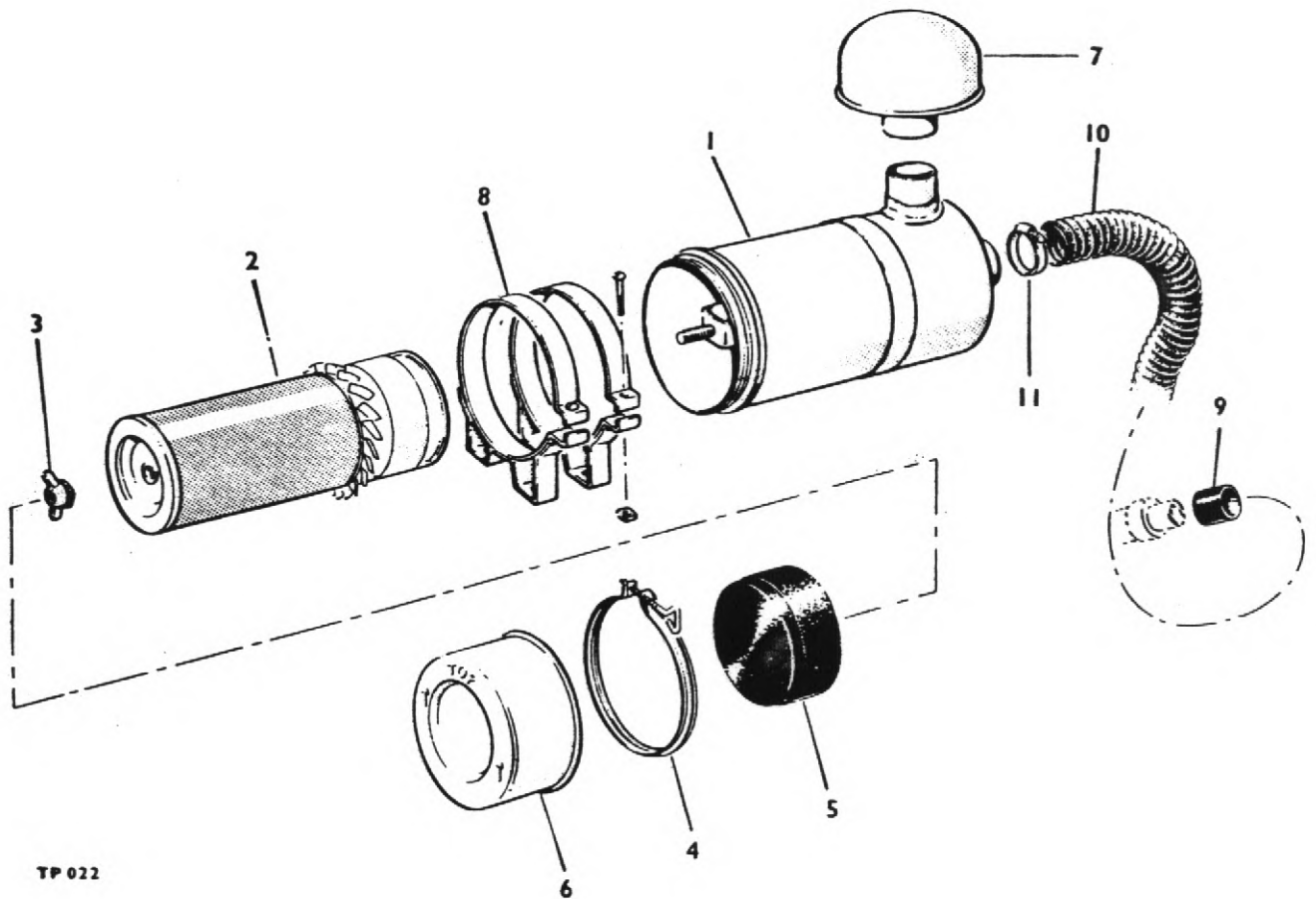

TP 022

AIR CLEANER

Item No.	Part No.	Description	Qty.
1	10532A02	Air Cleaner Assembly	1
2	10532A0101	Element	1
3	V600487	Nut & Gasket Kit	1
4	220229002	Clamp Body	1
5	220229003	Skirt, baffle	1
6	220229004	Cup	1
7	10534A02	Stack Cap	1
8	10533A02	Bracket	2
9	10320A06	Sleeve Adapter	1
10		Hose Flexible 2" Bore x 35" Long	1
11	97S12	Clip Hose	2

DRUM BRAKE ASSEMBLY

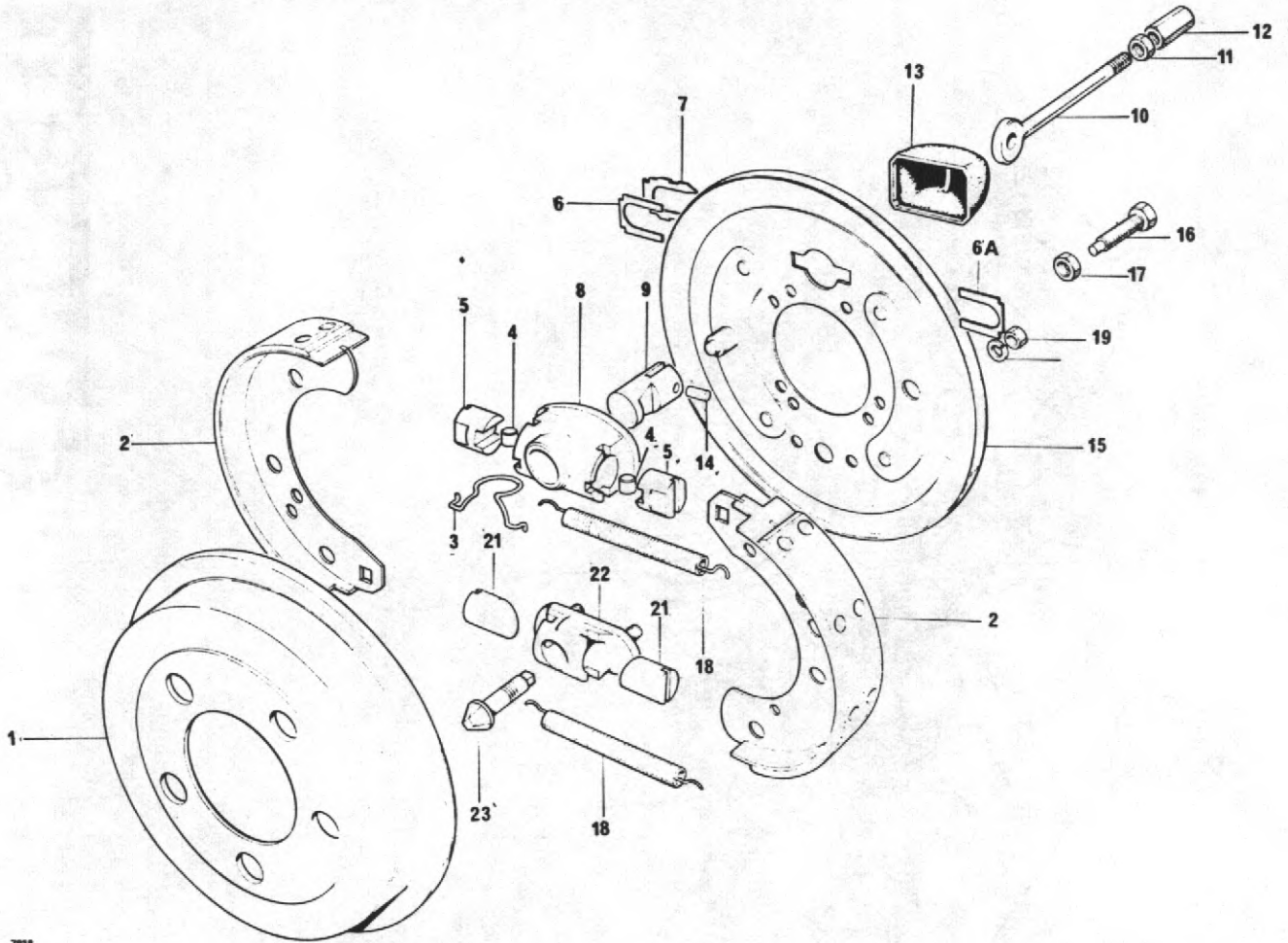

7818

Item	Part No.	Description	Qty.
1	30088.A0128	Brake Drum	1
2	20298.A0101	Lined Shoe	2
3	20298.A0102	Spring	1
4	20298.A0103	Roller	2
5	20298.A0104	Tappet Expander	2
6	20298.A0105	Plate	1
6A	20298.A0106	Plate	1
7	20298.A0107	Locking Plate	1
8	20298.A0108	Expander Housing	1
9	20298.A0109	Plunger	1
10	20298.A0110	Drawlink	1
11	20298.A0111	Locknut	1
12	20298.A0112	Barrel Nut	1
13	20298.A0113	Dust Cover	1
14	20298.A0114	Pin	1
15	20298.A0115	Brake Back Plate	1
16	1S.02C	Setscrew 5/16" BSF	2
17	1S.03	Nut 5/16" BSF	2
18	20298.A0116	Spring	2
19	20298.A0117	Nut	2
20	20298.A0118	Washer	2
21	20298.A0119	Tappet Adjuster	2
22	20298.A0120	Adjuster Housing	1
23	20298.A0121	Wedge	2
24	20298.A0122	Service Kit (Adjuster) (N.I.)	A/R
25	20298.A0123	Adjuster Assy. (Compr: 19-25)	A/R
26	20298.A0124	Expr. Assy. (Compr: items 3,4,5,8,9,10,11,12,& 14	A/R

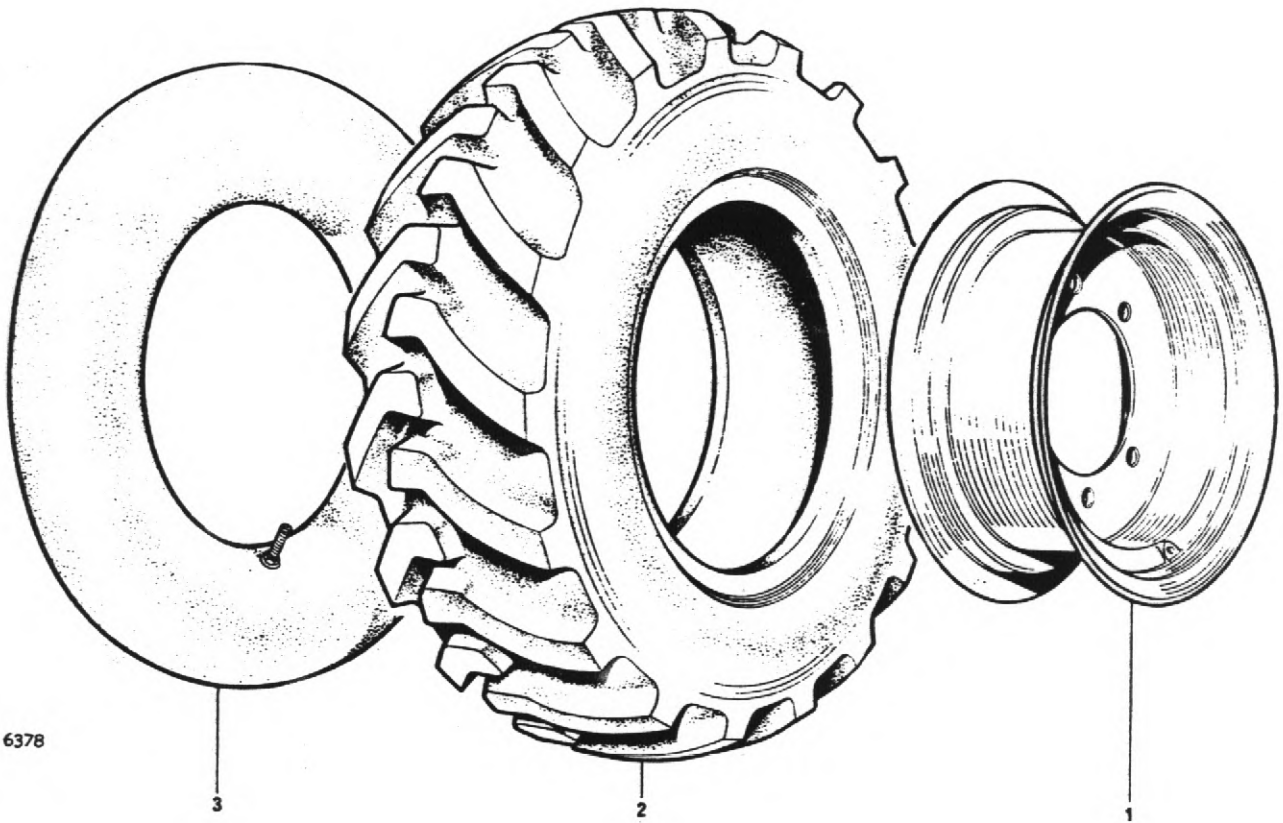

6378

DRIVE WHEELS AND TYRES

Item No.	Part No.	Description	Qty.
	24S04	R/H Wheel Assembly	1
	24S03	L/H Wheel Assembly	1
1	30192A01	Wheel rim 5.50 x 16	2
2	20S08	Tyre 7.50 x 16-6 ply	2
3	23S03	Tube 7.50 x 16	2

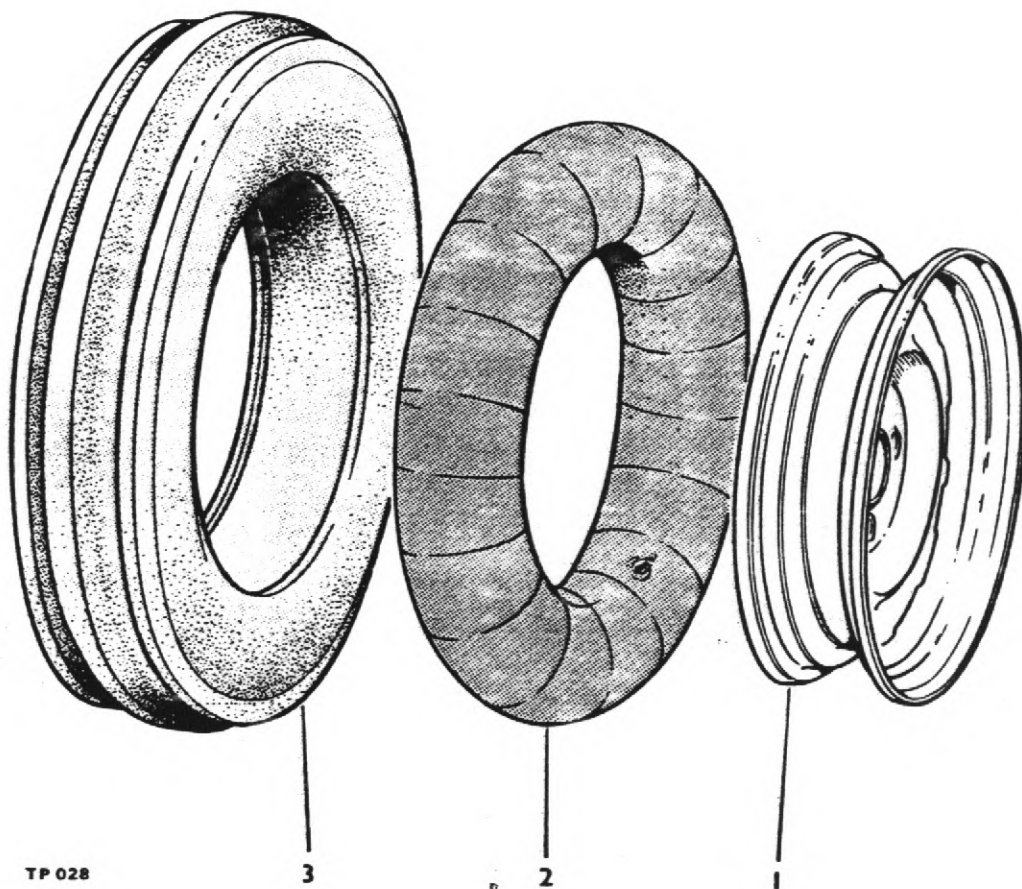

STEERING WHEELS AND TYRES

Item No.	Part No.	Description	Qty.
1	24S37	Steering wheel complete	2
2	LP598	Wheel rim 4.00 x 16	2
2	23S01	Tube 5.50 x 16	2
3	21S02	Tyre 5.50 x 16-6 ply	2

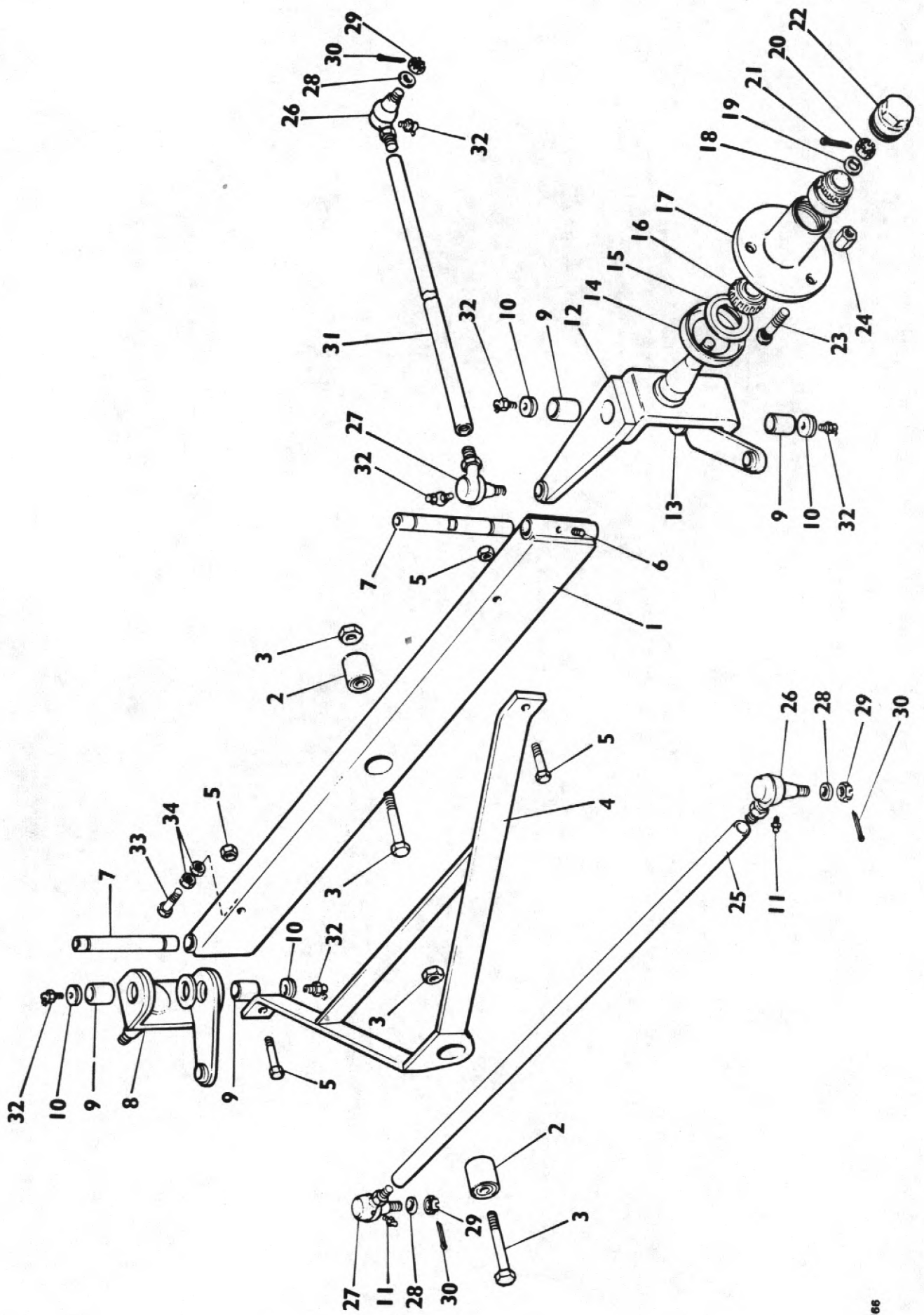

STEERING ASSEMBLY

Item No.	Part No.	Description	Qty
1	L-261	Axle Beam	1
2	E-2245	Axle & Stabiliser Bush	2
3	BOLT 6\$06MM NUT 9\$07	Axle & Stabiliser Pivot Bolt 7/8" UNF x 4" long & Nut	2
4	L-262	Axle Stabiliser	1
5	BOLT 6\$06MM NUT 87\$07	Bolt 5/8" UNF x 3 1/2" long & Nut	2
6	C-111A	King Pin retaining screw 7/16" whit	2
7	L-264	King Pin	2
8	L-267-L.H.	Stub Axle Assembly L.H.	1
9	C-190	King Pin Bush	4
10	C-180A	King Pin washer - felt	4
	C-180B	King Pin washer - steel	4
11	T-ST	Grease nipple	2
12	L-267-R.H.	Stub Axle Assembly R.H.	1
13	C-175	Thrust washer	2
14	EC-2752	Dust Cover	2
15	C-186C	Hub bearing Oil seal	2
16	K-14138-1	Hub bearing (Inner)	2
17	C186	Hub Assembly Complete (Including items 14,15,16, 18,22,23, & 24)	2
18	K-09074	Hub bearing (outer)	2
19		Hub washer 5/8" dia bright	A/R
20	C-186B	Hub Nut 5/8" BSF slotted	2
21		Split Pin 1/8" dia	2
22	C-186A	Hub Cap	2
23	0156	Wheel stud	6
24	C-177	Wheel Nut	6
25	L-308T	Track Rod	1
26	C-159-L.H.	Steering Ball Joint L.H.	2
27	C-159-R.H.	Steering Ball Joint R.H.	2
28		Flat washer	4
29		Slotted Nut	4
30		Split Pin 1/8" dia x 1" long	4
31	L-308D	Drag Link	1
32	13\$02	Grease nipple	6
33	6\$06F	Stop Bolt 5/8" UNF x 2" long	2
34	95\$06	Locknut 5/8" UNF	4

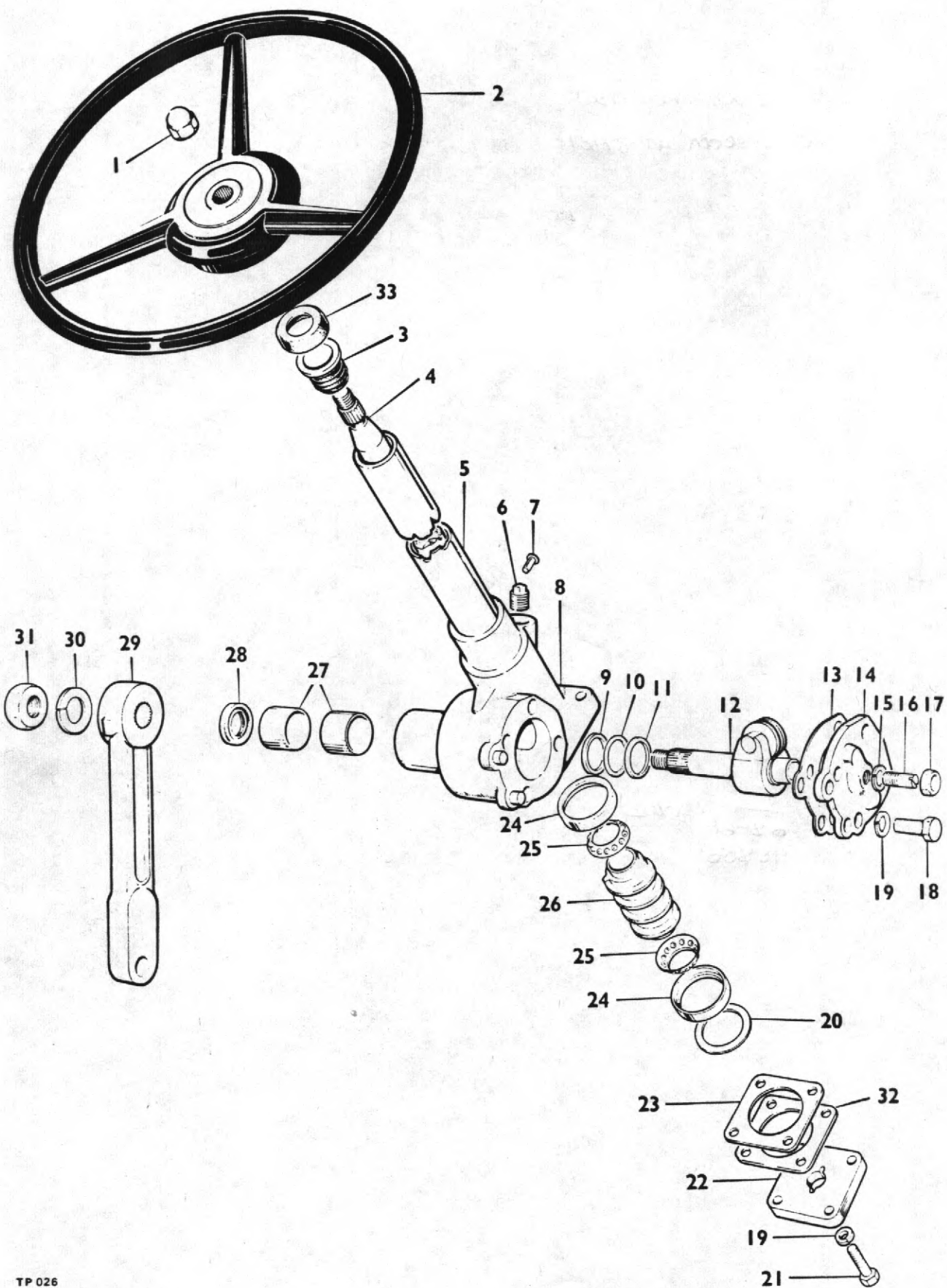

STEERING GEAR (CAM AND ROLLER TYPE)

Item No.	Part No.	Description	Qty.
	MGA 34849	Steering column assy. complete less items, 1,2 & 29	1
1	C 304	Steering wheel nut	1
2	347 K	Steering wheel	1
3	PA3904A	Column top bush	1
4	P5244/30"	Inner shaft	1
5	P3911/24"	Outer tube	1
6	S 9033	Oil plug	1
7	S 9166	Pin	1
8	PA4426	Steering box c/w item 14	1
9	P4151	Thrust washer	2
10	P 3308	Shim	A/R
11	P 4150	Thrust washer	2
12	PA5229/4¼"	Rocker shaft c/w roller	1
13	P3306A	Cover plate gasket	A/R
14	QA757	Cover plate and bush	1
15	S 999	Spring washer	1
16	P 4222	Adjuster screw	1
17	P 4221	Nut	1
18	S 9240	Setscrew	4
19	S 902	Spring washer	8
20	P3342	Washer	1
21	S 9300	Setscrew	4
22	P 3907	Bottom cap	1
23	P 3301/.005"	Shim	A/R
24	P 3341	Outer race	2
25	PA2733	Cage and balls	2
26	P 3340	Cam	1
27	P 3309	Bush	2
28	S 9242	Oil seal	1
29	M 29629	Drop arm	1
30	S 955	Spring washer	1
31	S 9332	Nut	1
32	P 3301G	Bottom cap liner	2
33	M33418	Inner column shroud	1

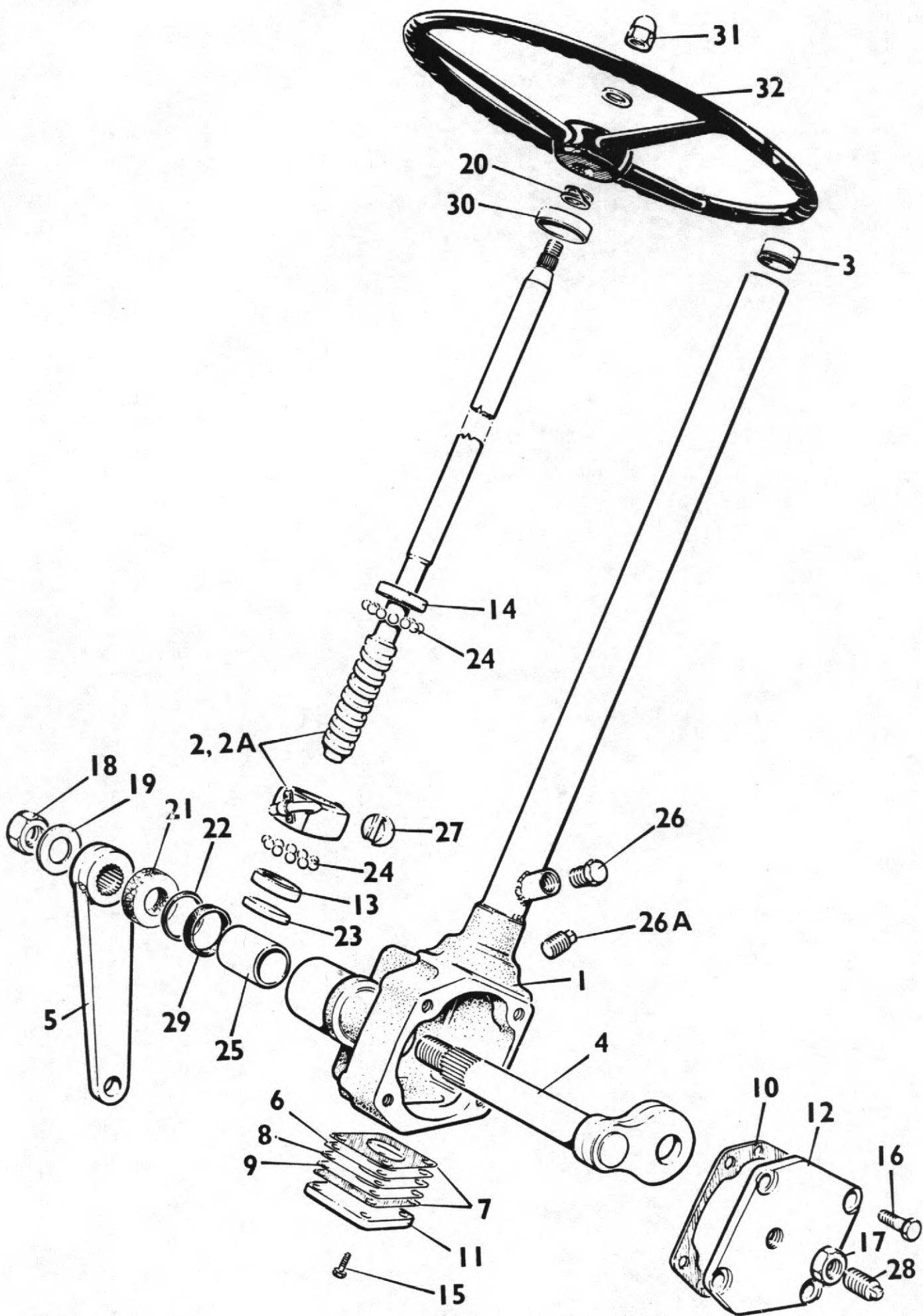

STEERING GEAR (RECIRCULATING BALL TYPE)

Item No	Part No.	Description	Qty
	11-077	Steering gear complete (less items 5 & 32)	
1	SA-01-183	Box and Tube assembly	1
2	SA-02-269	Inner column assembly and main nut (700mm long)	1
2A	SA-02-277	Inner column assembly and main nut (750mm long)	1
3	SA-21-004	Bearing assembly	1
4	S-7-103	Rocker shaft	1
5	2SE90	Drop arm	1
6	S-10-14	End plate shim .005"	3
7	S-10-15	End plate gasket	2
8	S-10-42	End plate shim .002"	2
9	S-10-111	End plate shim .010"	2
10	S-10-191	Cover plate gasket	1
11	S-11-83	End plate	1
12	S-12-186	Cover plate	1
13	S-23-32	Ballrace (small)	1
14	S-23-33	Ballrace (large)	1
15	10-3-37	End Plate bolt	4
16	10-4-16	Cover Plate bolt	4
17	11-7-2	Rocker shaft adjuster screw nut	1
18	11-8-7	Rocker shaft nut	1
19	12-8-36	Rocker shaft tab washer	1
20	12-8-85	Spring	1
21	12-9-61	Drop arm felt washer	1
22	12-10-7	Oil seal retaining washer	1
23	12-12-26	Inner column packing plate	1
24	17-3-4	Steel ball	54
25	19-9-17	Rocker shaft bush	1
26	21-8-4	Oil Plug	1
26A	21-7-2	Oil Plug	1
27	24-5-5	Main nut roller	1
28	25-7-2	Rocker shaft adjuster screw	1
29	27-9-6	Oil seal	1
30	32-8-8	Dust cap	1
31	11-7-45	Dome nut	1
32	347K	Steering wheel	1

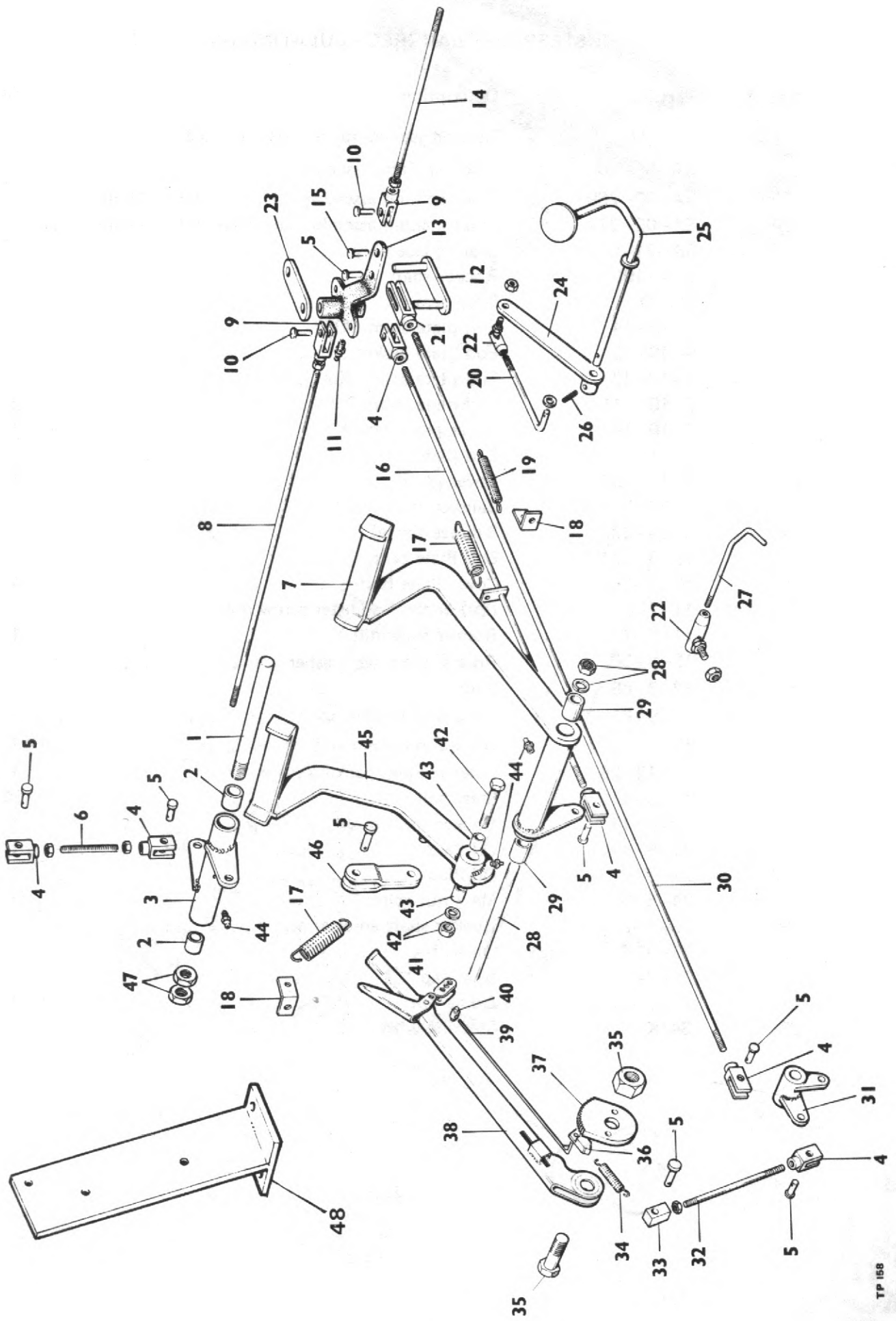

PEDALS & CONTROLS

Item No.	Part No.	Description	Qty.
1	L357	Clutch Transfer Lever Pivot Pin	1
2	WB 0808	Clutch Transfer Lever Bush	2
3	L280	Clutch Transfer Lever.	1
4	C 174 A	Fork End (Drum Brakes Only) ²⁺²⁺²	6
	C 174A	For End (Disc Brakes Only) ³	5
5	C 174 X	Clevis Pin (Drum Brakes Only) ²⁺²⁺²	8
	C 174 X	Clevis Pin (Disc Brakes Only) ³⁺²	6
6	C 184	Clutch Adjusting Rod (3/8" BSF)	1
7	C 122	Footbrake Pedal (Drum Brakes Only)	1
	C 258	Footbrake Pedal (Disc Brakes Only) - (Not Illustrated)	1
8	L 278 B	Brake Rod 1/4" UNF x 31.1/4" Long (Drum Brakes Only)	1
	L 329/2	Brake Rod 1/4" UNFx30.1/2" Long (Disc Brakes Only)	1
9	C 174 C	Clevis (Drum Brakes Only)	2
	C 174 C	Clevis (Disc Brakes Only)	4
10	C 174 Y	Clevis Pin (Drum Brakes Only)	2
	C 174 Y	Clevis Pin (Disc Brakes Only)	4
11	5ST 100	Grease Nipple	1
12	C 271	Compensator Link Assembly (Drum Brakes Only)	1
	C 189 B	Compensator Link Pin (Disc Brakes Only) (Not Illustrated)	2
13	C 272	Compensator Lever (Drum Brakes Only)	1
	5ST 76	Compensator Lever (Disc Brakes Only) (Not Illustrated)	1
14	L 278 A	Brake Rod 1/4" UNF x 8.3/4" Long (Drum Brakes Only)	1
	L 329/1	Brake Rod 1/4" UNF x 8.1/4" Long (Disc Brakes Only)	1
15	C 174 XL	Clevis Pin (For slotted fork) - (Drum brakes Only)	1
16	L 277A	Footbrake Rod 3/8" BSF x 40" Long (Drum brakes Only)	1
17	C 173 B	Return Spring	2
18	C 163	Spring Retainer	2
19	C 173 D	Accelerator Rod Return Spring	1
20	C 299	Accelerator Rod	1
21	C 174 B	Slotted Fork (Drum Brakes Only)	1
22	C 160 B	Ball End	2
23	C 189 A	Compensator Link (Drum Brakes Only)	1
	L 329/5	Compensator Link (Disc Brakes Only)	2
24	C 129	Accelerator Pedal Lever	1
25	C 137	Accelerator Pedal	1
26	C 129 A	Tension Pin 3/16" x 1.1/4" Long	1
27	C299-1	Priming Lever.	1
28	C319	Footbrake Pedal Pin and 2 Nuts ³ / ₄ " UNF	1
29	WB 1212	Footbrake Pedal Bush	2
30	L 277 B	H/Brake Rod 3/8" BSF x 47.1/2" (Drum Brakes Only)	1
	L329/3	H/Brake Rod 3/8" BSF x 49.1/2" (Disc Brakes Only)	1
31	L 292	H/Brake Transfer Lever	1
32	L 306	H/Brake Connecting Rod	1
33	L 309	H/Brake Rod End	1
34	14423/A	H/Brake Pawl Spring	1
35	L298	H/Brake Lever Carrier Bolt and Nut	1
36	14418/A	Pawl	1
37	C 156/A	H/Brake Lever Quadrant	1
38	L 291	H/Brake Assembly Complete	1
39	14419/A	H/Brake Pawl Rod	1
40	000022/A	Pin, Latch Pivot Arm	1
41	14425 A	Arm, Latch Pivot	1
42	C 126/A	Clutch Pedal Bolt and Nut	1
43	WB 1010	Clutch Pedal Bush	2
44	T/ST	Grease Nipple	3
45	C 126	Clutch Pedal	1
46	L 296	Clutch Connecting Link	1
47		Half Nut 1/2" BSF	2
48	3SHD 55	Control Valve Bracket	1

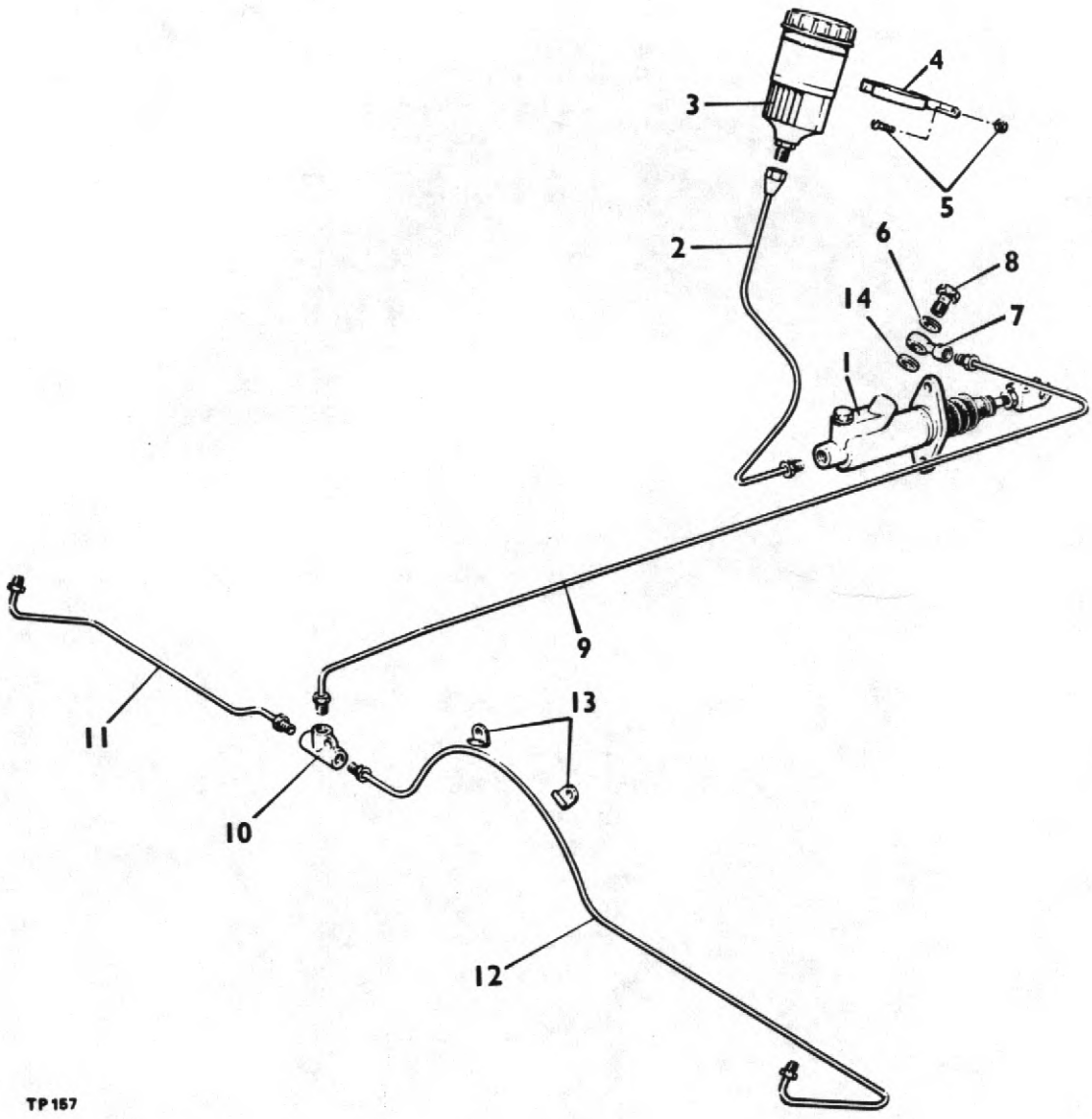

TP 157

BRAKE PIPES AND FITTINGS

Item No.	Part No.	Description	Qty
1	64067970	Master Cylinder (complete)	1
2	DM 89-1	Pipe 1/4" dia x 21" long (master cylinder to reservoir)	1
3	64046158	Reservoir	1
4	64477544	Reservoir clip	1
5		Screw 2BA x 1/2" long & locknut	2
6	378700	Copper washer	1
7	64474287	Banjo	1
8	376102W	Banjo Bolt	1
9	DM78-3	Pipe 3/16" dia x 43" long (master cylinder to tee)	1
10	64474341	Tee piece	1
11	DM78-2	Pipe 3/16" dia x 21" long (tee to RH brake caliper)	1
12	DM78-1	Pipe 3/16" dia x 38" long (tee to LH brake caliper)	1
13	4S132	Clip	1
14	378703	Copper washer	1

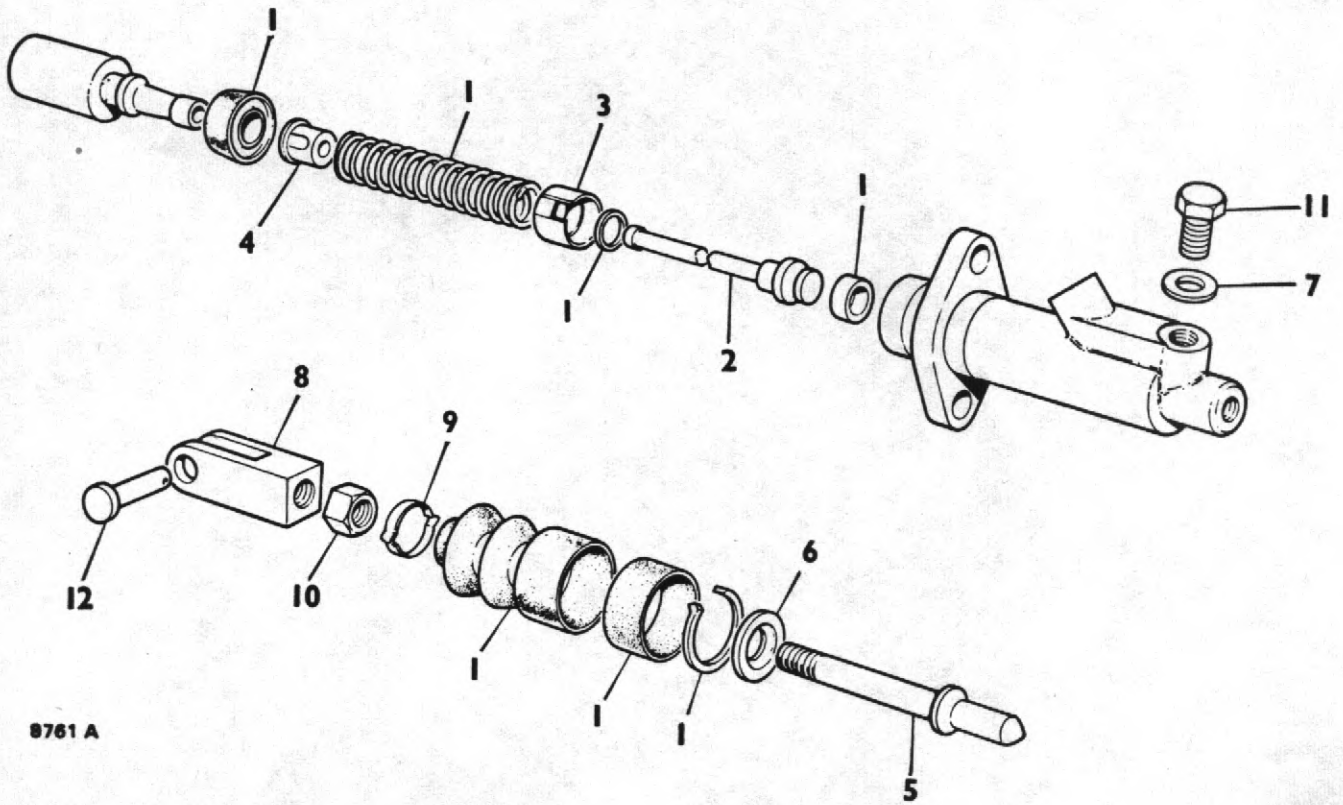

8761 A

MASTER CYLINDER ASSEMBLY

Item No.	Part No.	Description	Qty.
	64067970	Master Cylinder (Complete)	1
1	SP 1996/2	Seal Kit	1
2	378641	Valve Stem	1
3	318001	Valve Spacer	1
4	64673391	Valve Spring Retainer	1
5	351257 W	Push Rod	1
6	378242	Retaining Washer	1
7	378700	Washer	1
8	64671286	Clevis	1
9	378312	Dust Cover Retainer	1
10	64100052	Locknut	1
11	64110348	Plug	1
12	C174 Y	Clevis Pin	1

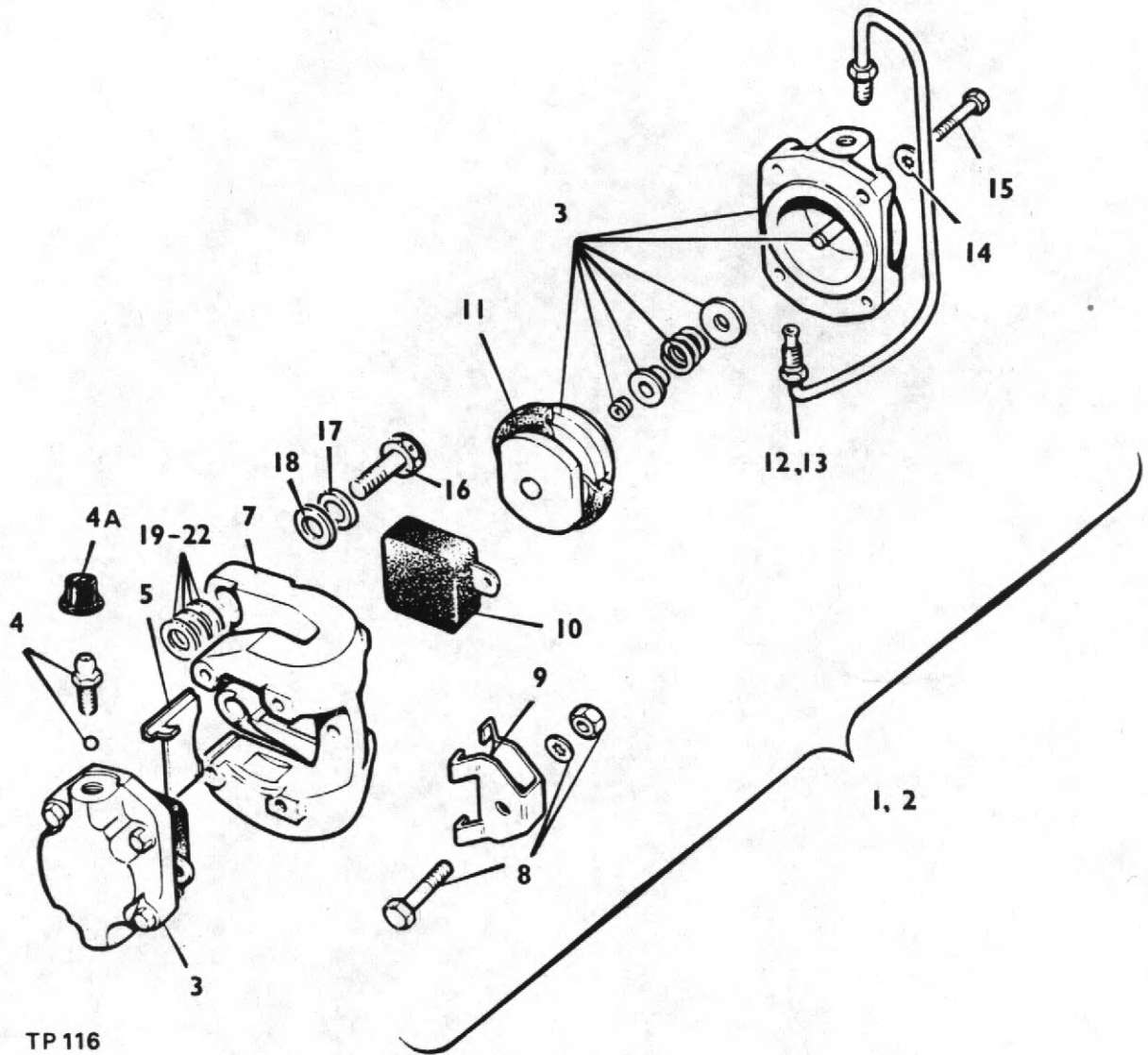

TP 116

BRAKE CALIPER ASSEMBLY

Item No.	Part No.	Description	Qty
1	CB 90262	Caliper Assembly Complete (RH)	1
2	CB 90263	Caliper Assembly Complete (LH)	1
3	VBO 5505	Piston and Cylinder Assembly	2
4	VBO 8378	Bleed Screw and Ball Assembly	1
4A	CBO 849	Dust Cover (Bleedscrew)	1
5	VBO 5133	Plate, Support	1
6	CB 60253	Body, Caliper (LH)	1
7	CB 60252	Body, Caliper (RH)	1
8	VBO 8491	Nut, Bolt and Washer (Keep Plate)	1
9	VBO 5123	Keep Plate	1
10	VBO 8360Y	Friction Pad Complete (Set of 4)	1 set
11	VBO 8210A	Seal Kit (Dust & Piston)	2
12	VBO 3927	Bridge Pipe Assembly (LH)	1
13	VBO 3928	Bridge Pipe Assembly (RH)	1
14	VBO 6101L	Washer, Shakeproof	8
15	VBO 5100	Bolt, Retaining (Cylinder)	8
16	7BNF22B	Caliper mounting bolt	4
17	7W16	Washer	4
18	7W14	Washer	4
19	5HA138	Shim .003"	A/R
20	5HA139	Shim .005"	A/R
21	5HA140	Shim .010"	A/R
22	5HA141	Shim .030"	A/R

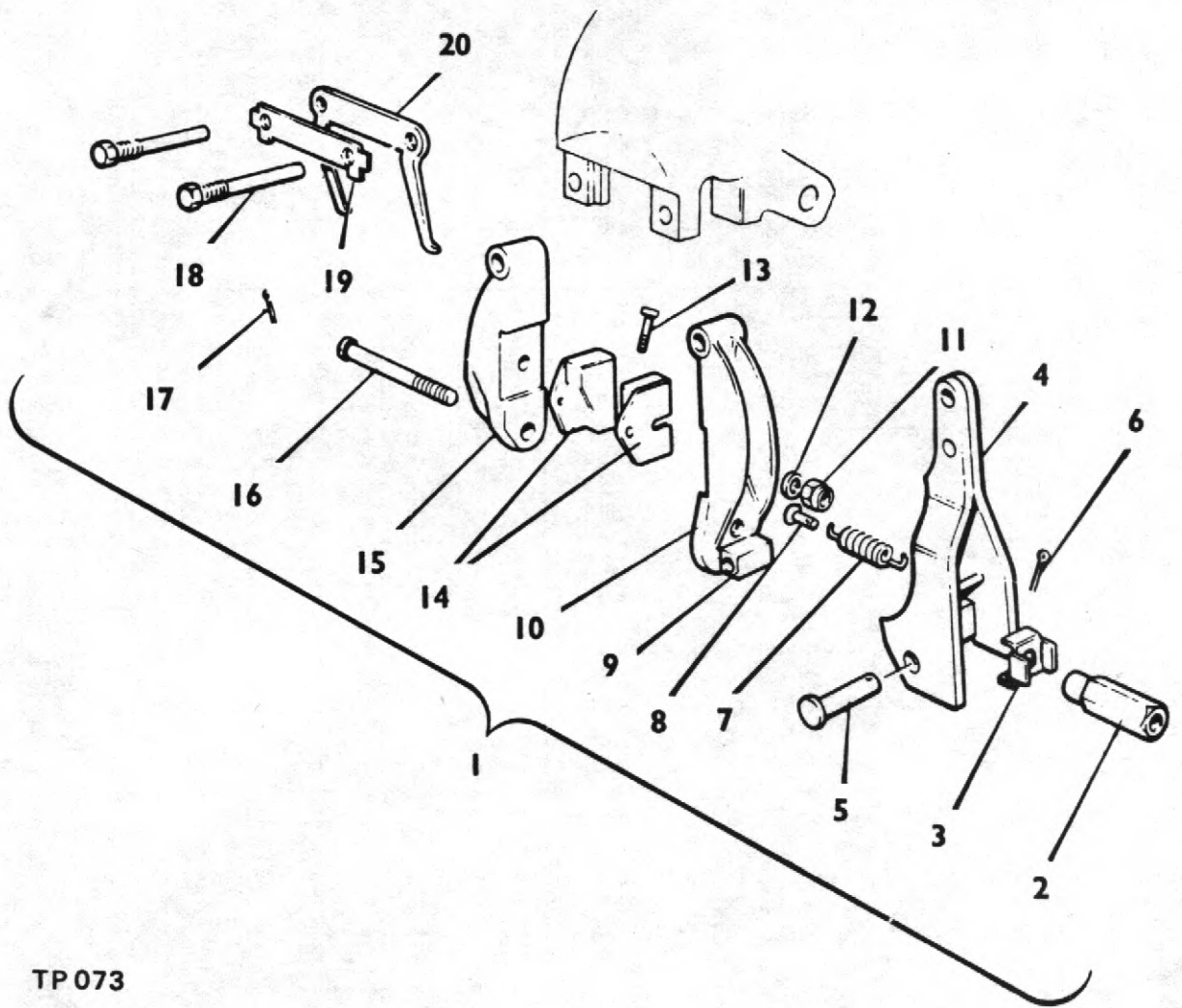

TP 073

HANDBRAKE ASSEMBLY

Item No.	Part No.	Description	Qty
1	CB 90256	Handbrake Assembly complete RH	1
	CB 90257	Handbrake Assembly complete LH	1
2	CB 20258	Adjustment Nut	1
3	VBO 8307	Friction Spring	1
4	CB 20562	Lever Assembly	1
5	VBO 8315	Hinge Pin	1
6	VBO 6135 D	Split Pin	1
7	VBO 7329	Return Spring	1
8	VBO 7330	Spring Anchor	1
9	VBO 8308	Pivot Seat	1
10	CB 60249 8308	Pad Carrier Assembly Inner Complete with Pivot Seat	1
11	VBO 6050	Nut 2 B.A.	2
12	VBO 6101F	Washer	2
13	VBO 4124	Bolt	2
14	CB 20311Y	Friction Pad	2
15	VBM 4573	Pad Carrier Outer	1
16	CB 20289	Bolt	1
17	VBO 6158G	Split Pin	1
18	VBO 4190	Bolt	2
19	VBO 4226	Tab Washer	1
20	VBM 4635/1	Retraction Plate	1

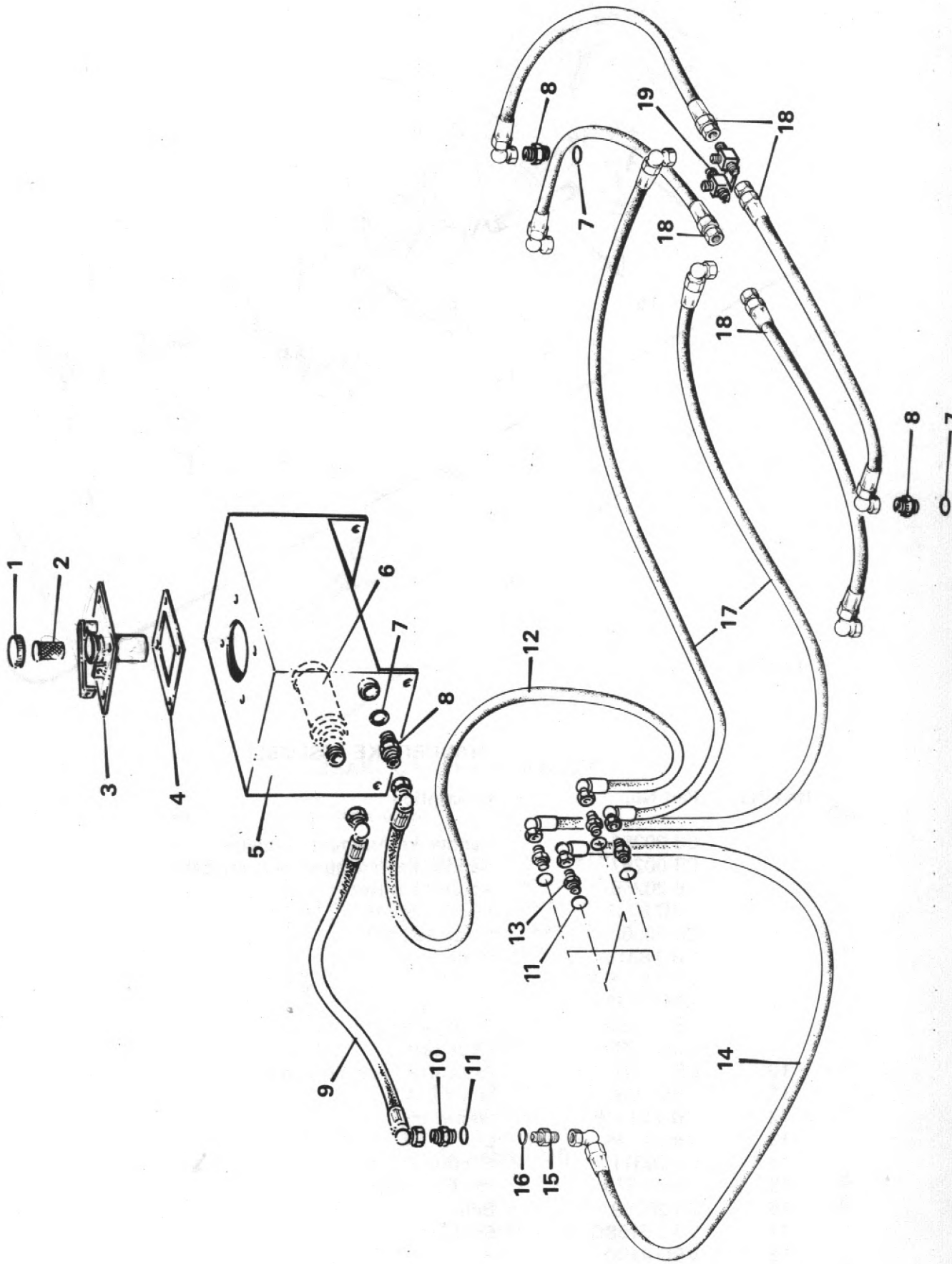

HYDRAULIC PIPES AND FITTINGS

Item No.	Part No.	Description	Qty
1	P 2578	Hydraulic tank cap	1
2	P 1145	Strainer	1
3	4-35-187	Cover Plate Assembly	1
4	T 18 B	Gasket	1
5	2ST 118	Hydraulic tank	1
6	UC 1457	Filter	1
7	T 14 I	Sealing washer	3
8	T 14 J	Adaptor $\frac{3}{8}$ " BSP x $\frac{3}{8}$ " BSP	3
9	2ST 72E	Hose 16" long 90 - 90 (tank to pump)	1
10	2ST 72F	Adaptor $\frac{3}{4}$ " J.I.C. x $\frac{1}{2}$ " BSP	1
11	2ST 72J	'O' Ring	5
12	5ST 85	Hose $\frac{3}{8}$ " x 27" long 90°-90° (valve to tank)	1
13	4-35-40K	Adaptor $\frac{3}{4}$ " JIC x $\frac{3}{8}$ " BSP	4
14	3SHD 67	Hose $\frac{3}{8}$ " x 47" long 90°-90° (pump to valve)	1
15	2ST 72G	Adaptor 9/16" JIC x $\frac{3}{8}$ " BSP	1
16	2ST 72K	'O' Ring	1
17	3SH 62	Hose $\frac{3}{8}$ " x 47" long 90°-90° (valve to Tee)	2
18	3SH 63	Hose $\frac{3}{8}$ " x 23 $\frac{1}{2}$ " ST-90 (Tee to Cylinders)	4
19	3SH 66	Six way Tee piece	1

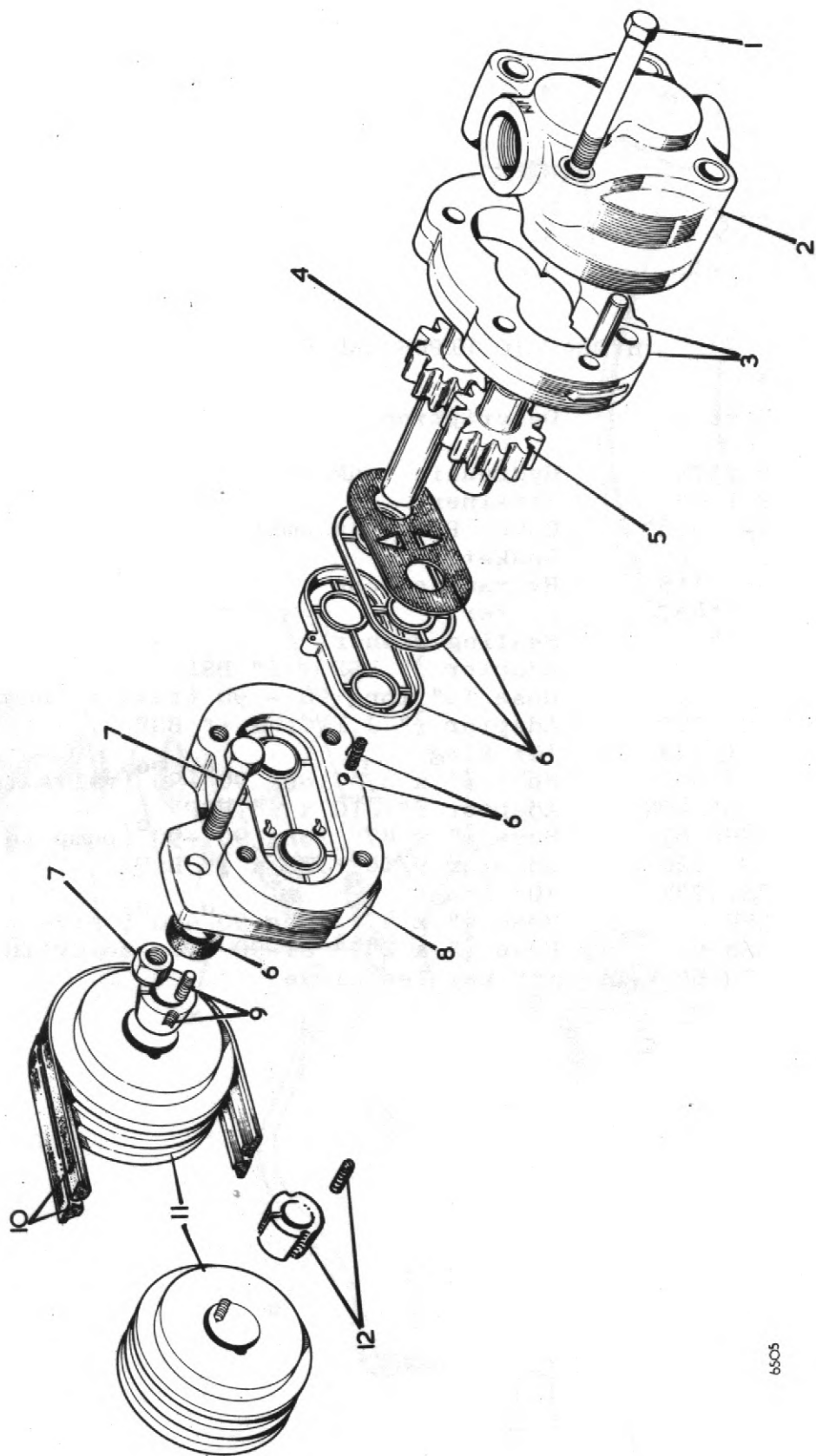

HYDRAULIC PUMP AND DRIVE

Item No.	Part No.	Description	Qty
	H20210-OAEA	Pump Assembly (Petter)	1
1	16032-522	Bolt	4
2	20200-36	Back Plate Assembly	1
3	20210-13	Body and dowel Assembly	1
4	20210-7	Drive gear Assembly	1
5	20210-8	Idler gear Assembly	1
6	20200-34	Seal Repair Kit	1
7		Pump mounting bolt	2
8	20200-20	Front plate Assembly	1
9	2ST 124	Taper lock bush	1
10	2ST 121	Wedge belt	2
11	2ST 122	Pulley	2
12	2ST 123	Taper lock bush	1
13	3SHD 84	Hyd. Pump Drive Guard Assy. (not illustrated)	1

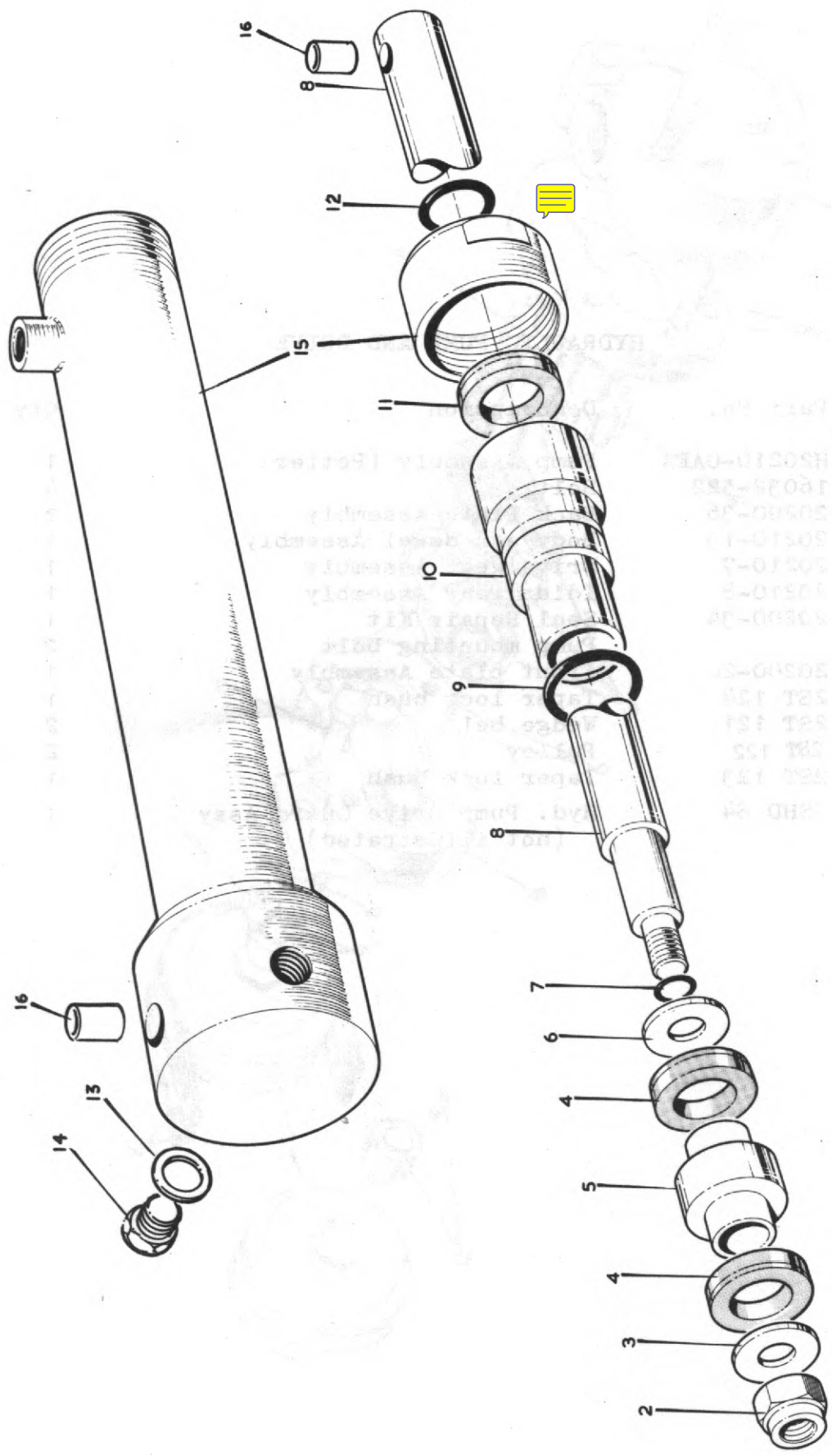

HYDRAULIC CYLINDER

Item No.	Part No.	Description	Qty
1	TD.10742	Cylinder (complete)	2
2		Locknut $\frac{5}{8}$ " BSF	1
3	LS.104-10	Backing washer	1
4	R.7784-S	Piston Seal	2
5	TD.2910	Piston Head	1
6	LS.104-11	Backing washer	1
7	BS.117	Piston 'O' Ring	1
8	TD.1873	Piston Rod	1
9	BS.224	Sleeve 'O' Ring	1
10	TD.2913	Sleeve	1
11	R.4041-S	Sleeve Seal	1
12	PP.58-13	Wiper	1
13		Copper washer $\frac{3}{8}$ " BSP	1
14	TD.1448-C	Plug	1
15	TD.4254	Cylinder (complete with tube cap)	1
16	10DU14	Glacier Bush	3
17	3SH 81	Seal Kit comprising items 4, 7, 9, 11 and 12	A/R

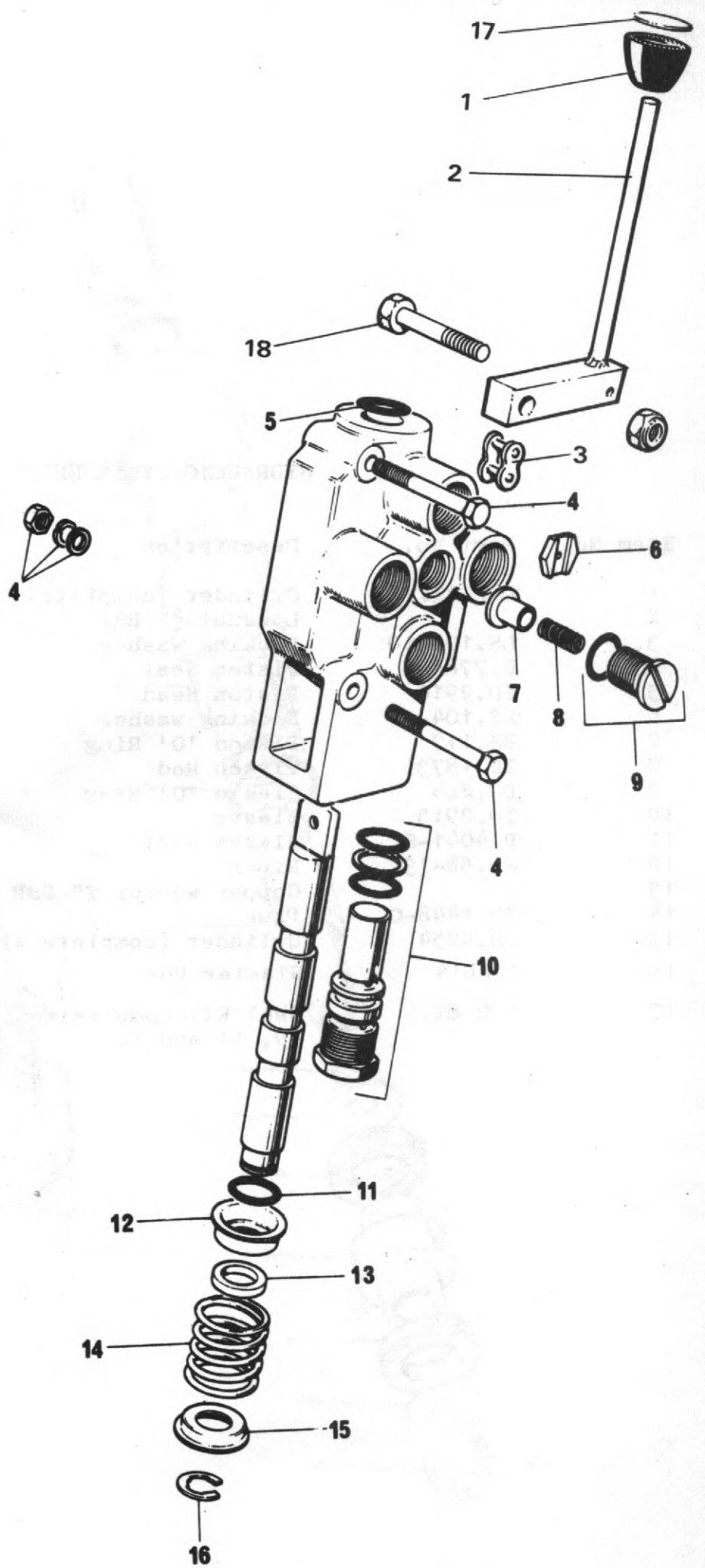

HYDRAULIC CONTROL VALVE

Item No.	Part No.	Description	No. Off
	3SH 88	Control Valve Assembly	
	300-024-AAD	Hydraulic Control Valve	1
1	F4-45-184	Control Knob	1
2	3SHD 82	Valve Control Lever	1
3	4-60-178	Connection Link	1
4		Bolt 5/16" UNF x 2½" Long, Nut and Washers	2
5	100-147-063	'O' Ring	1
6	16097-451	Orifice Plate	1
7	30501-12	Lift Check Plunger	1
8	30501-13	Lift Check Spring	1
9	30501-17	Lift Check Plug Assembly	1
10	30131A0107	Relief Valve Assembly	1
11	100-146-012	'O' Ring 3/32" dia. x 5/8" i/d	1
12	30501-10	Deep Washer	1
13	16048-31	Washer, Spacer	1
14	30501-39	Spool Spring	1
15	15546-6	Shallow Washer	1
16	16124-50	Clip Ring ½" Shaft	1
17	DM 156	Hyd. Valve Control Knob label	1
18		Bolt M10 x 50 mm long & nut	1
19	16097-3-35	Orifice Plate (Not Illustrated)	1

DECIMAL, FRACTIONAL AND METRIC EQUIVALENTS

Inches		Milli- metres	Inches		Milli- metres
Fractions	Decimals		Fractions	Decimals	
1/64	0.015625	0.397	33/64	0.515625	13.097
1/32	0.03125	0.794	17/32	0.53125	13.494
3/64	0.046875	1.191	35/64	0.546875	13.891
1/16	0.0625	1.588	9/16	0.5625	14.288
5/64	0.078125	1.984	37/64	0.578125	14.684
3/32	0.09375	2.381	19/32	0.59375	15.081
7/64	0.109375	2.778	39/64	0.609375	15.478
1/8	0.125	3.175	5/8	0.625	15.875
9/64	0.140625	3.572	41/64	0.640625	16.272
5/32	0.15625	3.969	21/32	0.65625	16.669
11/64	0.171875	4.366	43/64	0.671875	17.066
3/16	0.1875	4.763	11/16	0.6875	17.463
13/64	0.203125	5.159	45/64	0.703125	17.859
7/32	0.21875	5.556	23/32	0.71875	18.256
15/64	0.234375	5.953	47/64	0.734375	18.653
1/4	0.250	6.350	3/4	0.750	19.050
17/64	0.265625	6.747	49/64	0.765625	19.447
9/32	0.28125	7.144	25/32	0.78125	19.844
19/64	0.296875	7.541	51/64	0.796875	20.241
5/16	0.3125	7.938	13/16	0.8125	20.638
21/64	0.328125	8.334	53/64	0.828125	21.034
11/32	0.34375	8.731	27/32	0.84375	21.431
23/64	0.359375	9.128	55/64	0.859375	21.828
3/8	0.375	9.525	7/8	0.875	22.225
25/64	0.390625	9.922	57/64	0.890625	22.622
13/32	0.40625	10.319	29/32	0.90625	23.019
27/64	0.421875	10.716	59/64	0.921875	23.416
7/16	0.4375	11.113	15/16	0.9375	23.813
29/64	0.453125	11.509	61/64	0.953125	24.209
15/32	0.46875	11.906	31/32	0.96875	24.606
31/64	0.484375	12.303	63/64	0.984375	25.003
1/2	0.500	12.700	1	1.000	25.400

INCHES INTO MILLIMETRES

Inches	0	1	2	3	4	5	6	7	8	9
0	0	25.40	50.80	76.20	101.60	127.00	152.40	177.80	203.20	228.60
10	254.00	279.40	304.80	330.20	355.60	381.00	406.40	431.80	457.20	482.60
20	508.00	533.40	558.80	584.20	609.60	635.00	660.40	685.80	711.20	736.60
30	762.00	787.40	812.80	838.20	863.60	889.00	914.40	939.80	965.20	990.60
40	1016.00	1041.40	1066.80	1092.20	1117.60	1143.00	1168.40	1193.80	1219.20	1244.60
50	1270.00	1295.40	1320.80	1346.20	1371.60	1397.00	1422.40	1447.80	1473.20	1498.60
60	1524.00	1549.40	1574.80	1600.20	1625.60	1651.00	1678.40	1701.80	1727.20	1752.60
70	1778.00	1803.40	1828.80	1854.20	1879.60	1905.00	1930.40	1955.80	1981.20	2006.60
80	2032.00	2057.40	2082.80	2108.20	2133.60	2159.00	2184.40	2209.80	2235.20	2260.00
90	2286.00	2311.40	2336.80	2362.20	2387.60	2413.00	2438.40	2463.80	2489.20	2514.61

Use in conjunction with above table.

Example: Find equivalent mm. for 84 5/8".

$$84'' = 2133.60 \text{ mm.}$$

$$5/8'' = 15.875 \text{ mm.}$$

$$84 \text{ } 5/8'' = 2149.475 \text{ mm.}$$

CALIFORNIA

Proposition 65 Warning

Diesel engine exhaust and some of its constituents are known to the State of California to cause cancer, birth defects, and other reproductive harm