

# MIXERS

## 100T 150T 175T

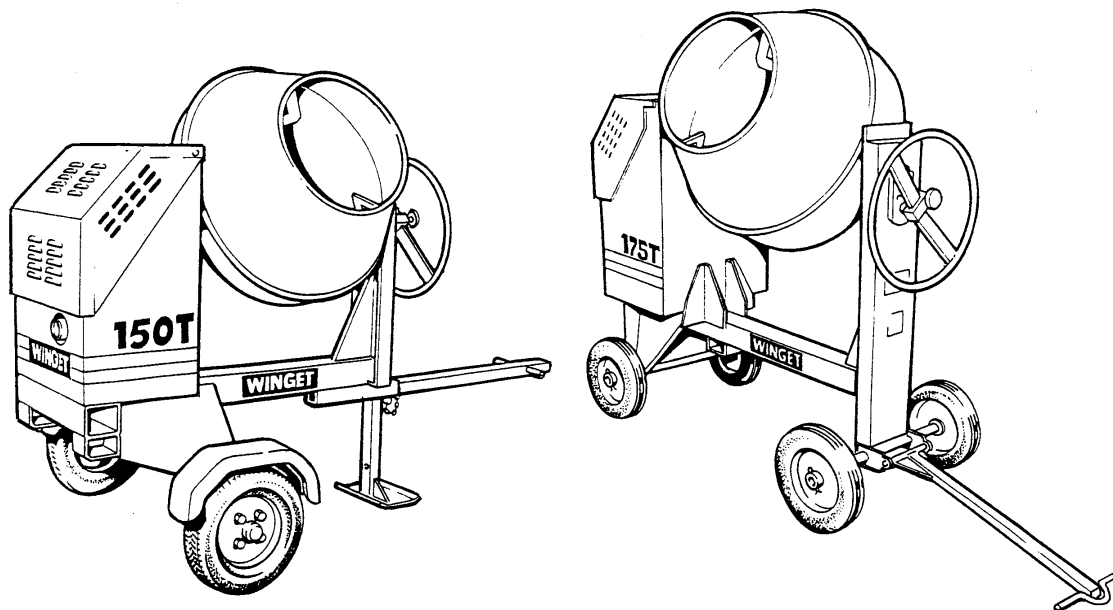

# OPERATORS HANDBOOK & PARTS

Manual V601318      *March 2022*

Up to Serial Number 100T-11751, 150T-05854  
175T-05857

# WINGET

WINGET LIMITED, P.O. Box 41, Edgefold Industrial Estate, Plodder Lane, Bolton, BL4 0LR, England  
Tel: +44 (0) 1204 854650  
[www.winget.co.uk](http://www.winget.co.uk)  
[parts@winget.co.uk](mailto:parts@winget.co.uk)

## CONTENTS

<b>Section</b>	<b>Page</b>
<b>INTRODUCTION</b>	
Introduction	III
Warranty	IV
Safe Working	1.1
Decals	1.3
Lashing down & lifting points	1.6
<b>OPERATION</b>	
Installation	2.1
LT1/LV1 engines	2.2
AC1-05 engines	2.4
Yanmar L40/L48 engines	2.5
Honda engines	2.8
Electric motors	2.10
Mixer drum positions	2.10
Mixing	2.10
Mixer drum rotation	2.11
End of work procedures	2.11
Lighting Board	2.12
<b>SERVICING</b>	
Service schedule	3.1
Greasing and lubrication	3.2
Drum drive	3.2
Bolt torques	3.3
Engines: ( <i>Lister-Petter only. For Yanmar and Honda engines see separate Operator's Manual</i> )	
Air cleaner	3.3
Oil change	3.4
Oil filter	3.5
Fuel filter & priming the fuel system	3.5
Battery	3.7
Mixer drum assembly	3.8
Mixer drum drive overhaul	3.10
Suspension units	3.11
Tyres	3.11

<b>Section</b>	<b>Page</b>
<b>TECHNICAL INFORMATION</b>	
Lubricants	4.1
Mixer drum sealant	4.1
Tyre pressures	4.1
Noise levels	4.1
Drum speed	4.1
Engines & Motors	4.1
Dimensions	4.2
Electrically driven mixers wiring	4.3
Lister-Petter AC1-05 key start wiring	4.4
Yanmar L40/L48 key start wiring	4.5

## PARTS

Illustrations of all mixer components (at rear of book)

## THE HANDBOOK

The contents of this Handbook, although correct at the time of publication may be subject to alteration by the Manufactures without notice. Winget Limited operate a policy of continuous product development. Therefore, some illustrations or text within this publication may differ from your machine.

### WARNING



*The operator must read all the Handbook and fully understand its contents before attempting to operate the machine.*

### THE HANDBOOK MUST NOT BE REMOVED FROM THE MACHINE.

The Handbook must be kept clean and in good condition. Additional copies of the Handbook can be obtained from your Distributor.

The contents of this Operator's Handbook are designed as a guide to the machine's controls, operation, working capacities and maintenance. It is **not** a training manual.

Only trained operators should use this machine. Contact the C.I.T.B. or equivalent body for advice on training.

### WARNING



In this Handbook are **WARNING** notes. They are preceded by this symbol:

### WARNING



*These notes are used to indicate the procedure being described in the Handbook must be followed to avoid serious injury or death to yourself or to others; or damage to the machine.*

*The warnings are also used to protect the machine from unsafe servicing practices.*

Pay particular attention to the warnings given in the Handbook.

If you have any doubts about any aspect of the machine's capability or servicing procedures, you must consult the manufacturer.

## WARRANTY TERMS & CONDITIONS

The Manufacturer assures you that if any part of the machine becomes defective due to faulty manufacture or materials within 12 months from the date of purchase, the part will be repaired or replaced under warranty free of charge by any authorised Winget Distributor. Warranty repairs **must** be carried out by Winget Distributors.

This Warranty is given to the first owner and may be transferred to subsequent owners for the balance of the Warranty period.

The Manufacturer's liability only extends to the costs of repair or replacement of the faulty parts and necessary labour charges involved in the repairs. The Company accepts no liability for any consequential loss, damage or injury, resulting directly or indirectly from any defect in the goods.

Items not covered by Warranty and considered to be the customer's responsibility include normal maintenance services; replacement of service items and consumables; replacement required due to abuse, accident, misuse or improper operation; replacement of wearable items e.g. pins, bushes, brake linings, clutch linings etc.

The Warranty will not apply where the equipment is modified, converted, or used for purposes other than those for which it was designed, unless clearance for the modifications etc. have been granted by the Manufacturer, in writing.

The Pre-Delivery Inspection and Warranty Registration Document must be completed correctly and returned to the Manufacturer within 7 days of sale date. Failure to do so may result in the claim being subsequently rejected.

Tyres and tubes are not covered by Warranty, but are covered by the tyre manufacturer's own warranty system which provides against defects in material or workmanship. Engines are covered separately by the engine manufacturers, and engine warranty repairs must be handled by the relevant engine manufacturers' distributors.

No claim will be considered if other than genuine Winget Limited parts, which must be obtained from Winget Limited via an authorised Distributor, are used to effect a repair, or if lubricants other than those recommended by Winget Limited are used.

The equipment must be serviced in accordance with the service schedules laid down by Winget Limited. Evidence that these have been complied with may be required before Warranty Claims are reimbursed.

The Manufacturer's policy is one of continuous improvement. Winget Limited reserve the right to change specifications without notice. No responsibility will be accepted for discrepancies which may occur between specification of machines and the descriptions contained in publications.

Safety is the responsibility of the persons working with this machine. Think “safety” at all times. ***Read and remember the contents of this Handbook.***

## **MACHINE MODIFICATION**

### **WARNING**



Any modifications to the machine will affect its working parameters and safety factors. Refer to the Manufacturers before fitting any non-standard equipment or parts.

The manufacturers accept no responsibility for any modifications made after the machine has left the factory, unless previously agreed by the Manufacturers in writing. The Manufacturers will accept no liability for damage to property, personnel or the machine if failure is brought about due to such modifications, or fitment of spurious parts.

## **OPERATION**

### **WARNING**



Only trained operators should use this machine.

Always be aware of local and national regulations governing the use of the machine.

Always ensure that all guards are in position and correctly fitted.

***Electrically driven mixers:*** Always ensure that the power supply has been correctly connected by a qualified electrician.

Electrical cables must be of a suitably armoured type. Ensure that they are protected from damage and not liable to be tripped over.

Do not connect to a household socket!

Use only with an RCD protected supply. Only connect via special feeding point (e.g. power distribution panel on building site with fault-current-breaker).

Only authorised persons should be allowed to operate the mixer, or be in the immediate area.

Never add fuel or lubricant to the machine while it is running.

Keep the area around the machine clear of obstructions which could cause persons to fall onto moving parts.

Keep the body and clothing clear of all moving and hot parts.

Always ensure that during operation the mixer is standing on stable and level ground and that the wheels are chocked.

Keep the engine/motor housing lid closed when the engine or electric motor are running.

The towing speeds of *Fast Tow* mixers, when used on public highways, may be subject to local or national road traffic regulations.

**ENGINE****WARNING**

Starting any diesel engine can be dangerous in the hands of inexperienced people. Operators must be instructed in the correct procedures before attempting to start any engine.

Always obtain advice before mixing oils; some oils are not compatible. If in doubt, drain and refill.

The materials used in the manufacture and treatment of some filters and elements may cause irritation or discomfort if they come into contact with the eyes or mouth and they may give off toxic gases if they are burnt.

Engine lifting eyes must not be used to lift the complete machine.

Ether based cold start aids in aerosol cans must not be used under any circumstances.

**EXHAUST GASES CONTAIN CARBON MONOXIDE WHICH IS A COLOURLESS, ODOURLESS AND POISONOUS GAS THAT CAN CAUSE UNCONSCIOUSNESS AND DEATH.**

**ELECTRICAL SYSTEMS****WARNING**

Starting engines that are fitted with charge windings which have been disconnected from the battery will cause irreparable damage unless the stator leads from the rectifier/regulator have been removed.

The following points must be strictly observed when charge windings are fitted otherwise serious damage can be done.

Never remove any electrical cable while the battery is connected in the circuit.

Only disconnect the battery with the engine stopped and all switches in the OFF position.

Always ensure that cables are fitted to their correct terminals. A short circuit or reversal of polarity will ruin diodes and transistors.

Never connect a battery into the system without checking that the voltage and polarity are correct.

Never flash any connection to check the current flow.

Never experiment with any adjustments or repairs to the system.

The battery and charge windings must be disconnected before commencing any electric welding when a pole strap is directly or indirectly connected to the engine.

**BATTERIES CONTAIN SULPHURIC ACID WHICH CAN CAUSE SEVERE BURNS AND PRODUCE EXPLOSIVE GASES.** If the acid has been splashed on the skin, eyes or clothes flush with copious amounts of fresh water and seek immediate medical aid.

**SERVING & MAINTENANCE****WARNING**

Never allow unqualified personnel to attempt to remove or replace any part of the machine, or anyone to remove large or heavy components without adequate lifting equipment.

Before maintenance work is begun, ensure that the engine is stopped, or that the electric motor is switched off, and isolated from the mains.

*Note:* Pressing the stop or emergency stop buttons on the mixer will not isolate the machine from the mains

Always conform to service schedules except when an emergency calls for immediate action, or adverse conditions necessitate more frequent servicing.

Always report any defect at once, before an accident or consequential damage can occur.

On completion of maintenance, check that the machine functions correctly, and that all guards are correctly fitted.

**Disposal of waste oil.** Dispose of waste oil into waste oil storage tanks. If storage tanks are not available, consult your Distributor or local authority for addresses of local designated disposal points. It is illegal to dispose of waste oil into drains or water courses, or to bury it.

**DECALS**

Ensure that all warning decals fitted to the mixer are legible. If any should become detached, they must be replaced immediately.

**Descriptions of the pictorial decals are as follows:**

Fuel tank filling point.



Read Operators Handbook, or Operators Handbook storage place.

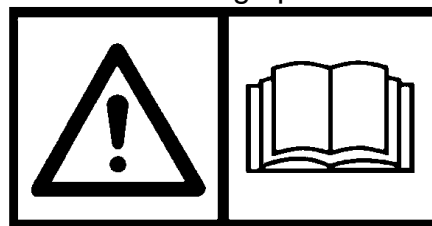

Attach lifting hooks to this eye.



The battery negative terminal is connected to earth.

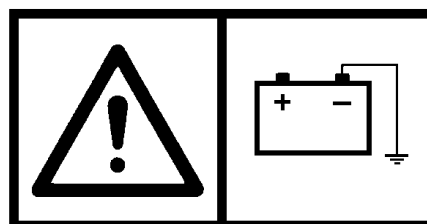

Remove starting handle.



Keep hands clear of drum.

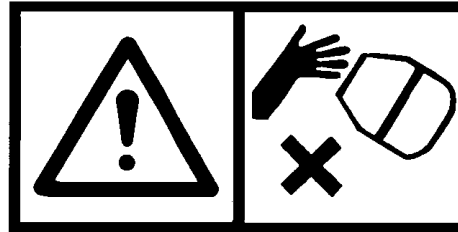

Beware of electrical hazards.

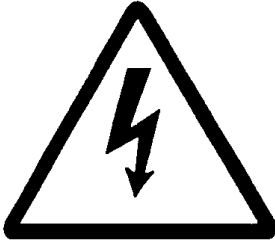

Battery isolator.

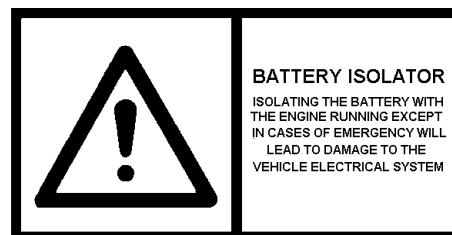

Engine stop.

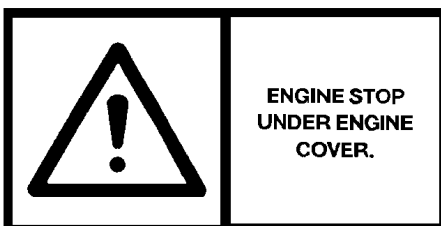

Keep clear of chain drives.

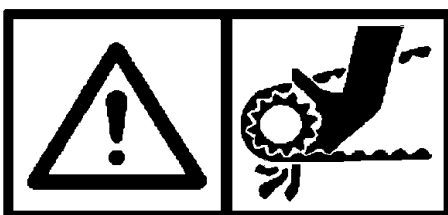

These surfaces may be hot.





ISO 8999 safety symbols used with Lister/Petter engines



Read the handbook

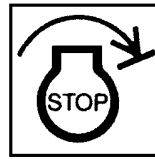
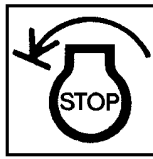

Stop control (on engine)

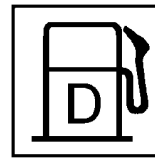

Diesel fuel fill



Engine oil fill

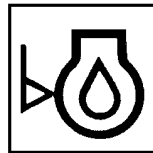

Engine oil level

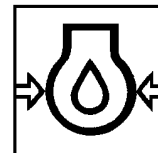

Engine oil pressure

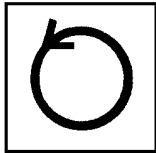

Anti-clockwise rotation

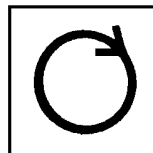

Clockwise rotation

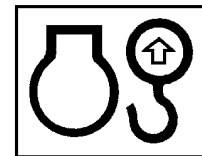

Lifting eye - engine only

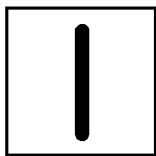

On

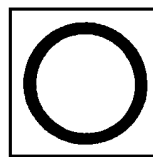

Off

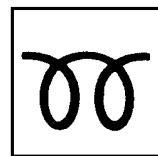

Pre-heat



Rotational speed control



Linear speed control



Tachometer



Elapsed hours

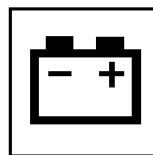

Battery charging



Engine cranking

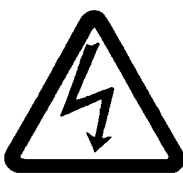

Electrical hazards



General hot surface warning

## Lashing down & Lifting points

### General

Care should be taken when lifting or transporting the mixer to ensure that lifting or retaining straps are in good condition and the following procedures must be followed when lifting or lashing down to avoid causing unnecessary damage.

It is recommended that chains or webbing slings are used to lift the mixer via the lifting point on the trunnion and that ratchet type webbing straps are used to lash the mixer down.

### Lifting the Mixer (Crane)

Turn the drum and trunnion through 180deg. and, using the locking pin in the tilting handwheel, lock the assembly in this position with the lifting eye 'A' uppermost. Attach suitable lifting equipment to the lifting eye and slowly take the weight. Do not 'snatch' the mixer otherwise damage may be caused to the lifting point, trunnion or lifting equipment. To prevent the drawbar swinging freely as the mixer clears the ground, rest the drawbar's 'T' handle on the mainframe below the upturned drum. If the mixer is on site and the wheels are immersed in dried concrete or mortar the wheels must be freed before attempts are made to lift the mixer. Be aware that the mixer will tend to swing as it clears the ground.

### Lifting the Mixer (Forklift/Telehandler)

Using the tilting handwheel locking plunger, lock the drum upright as illustrated overleaf. If the wheels are immersed in dried concrete or mortar, free them before attempting to lift the mixer.

Spread the fork tines and carefully position the forks below the mainframe so that one tine enters and passes through

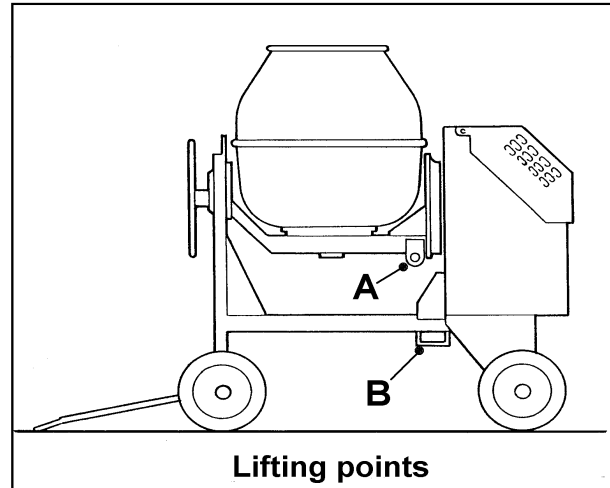

the bracket 'B' below the mainframe, the other fork should be spread as wide as possible. Position the carriage as close as possible to the mixer and rest the mixer's drawbar on one of the fork tines to prevent it swinging freely.

Slowly tilt the carriage back slightly to prevent the mixer rocking forward and raise the mixer just clear of the ground. Do not raise the mixer unnecessarily high, keep the height to the minimum required to clear any obstructions without unduly obstructing your forward vision. When travelling keep your speed to the minimum and when loading vehicles do not raise the mixer to the height of the bed until the mixer is close to the vehicle. Similarly when unloading vehicles lower the mixer just clear of the ground as soon as it clears the side of the vehicle.

### Lashing Down

It is recommended that unless the mixer is pulled up against a headboard or some form of substantial wheel chocks that two ratchet type webbing straps are used to retain the mixer, one pulling to the rear and one pulling to the front. The drum should be locked in the upright position

shown above to keep the centre of gravity as low as possible.

Position the mixer on the vehicle bed and chock the rear wheels to prevent it rolling until lashed down. Turn the front axle so that the drawbar is below the mixer and not forming an obstruction on the vehicle bed. Lock the drum in the upright position. Pass one of the webbing straps between the drum and trunnion at point 'C' and secure the strap down to retaining hooks on the vehicle bed in front of the mixer. Pass the second strap between the drum and trunnion at point 'D' and secure the strap down to retaining hooks on the vehicle bed to the rear of the mixer. Tighten the straps by means of the ratchets until the mixer is securely held.

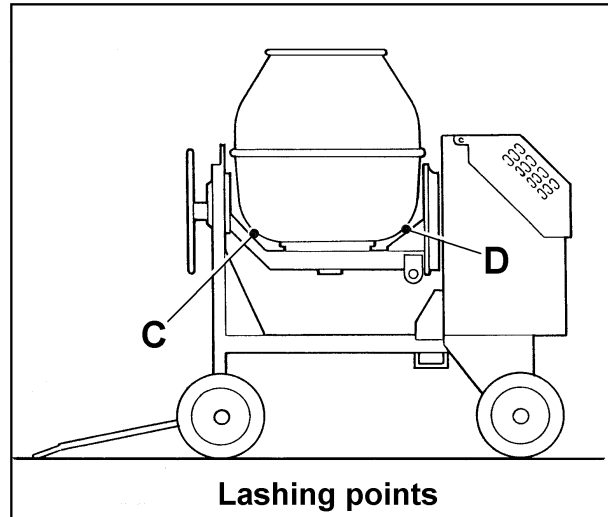



## INSTALLING THE MIXER ON SITE

Welded to the mixer are lifting points. These are provided to assist with loading or unloading the mixer and for transportation across site.

**WARNING** *For mixer weights, see "Specifications"*



Never carry mixers by their lifting points on public roads.

Do not tow four wheeled mixers across uneven ground.

The ground on which the mixer stands must be level and stable. Ensure that the wheels are chocked.

### **Electrically driven mixers:**

Always ensure that the power supply is correctly connected or disconnected by a qualified electrician.

Electrical cables must be of a suitably armoured type. Ensure that they are protected from damage and are not liable to be tripped over.

Do not connect to a household socket!

Use only with an RCD protected supply. Only connect via special feeding point (e.g. power distribution panel on building site with fault-current-breaker).

## ENGINE OPERATION

**WARNING** *As soon as the engine has started the mixing drum will begin to rotate.*



### **Before starting the engine:**

Ensure the engine is free to turn without obstruction.

Check that the lubricating oil level is

correct. The oil sump must be filled to the 'full' mark on the dipstick; do not overfill.

Check that the fuel supply is adequate and the system is primed.

### **Electric key start machines only:**

Ensure that the battery is connected, fully charged and serviceable.

## ENGINE SAFETY

**WARNING** *The following pages of engine operating instructions are of a general nature and should be read in conjunction with, or substituted by the engine manufacturers instructions.*



*Starting any diesel engine can be dangerous in the hands of inexperienced people.*

*Before attempting to start any engine the operator should read the 'Safe Working' section of this book and be conversant with the use of the engine controls and the correct starting procedures.*

**ETHER BASED COLD START AIDS IN AEROSOL CANS MUST NOT BE USED UNDER ANY CIRCUMSTANCES.**

**EXHAUST GASES CONTAIN CARBON MONOXIDE WHICH IS A COLOURLESS, ODOURLESS AND POISONOUS GAS THAT CAN CAUSE UNCONSCIOUSNESS AND DEATH.**

**LT/LV1 engine****Description**

- A Dipstick
- B Lubricating oil filler
- C Engine control
- D Decompressor lever
- E Air cleaner
- F Fuel tank

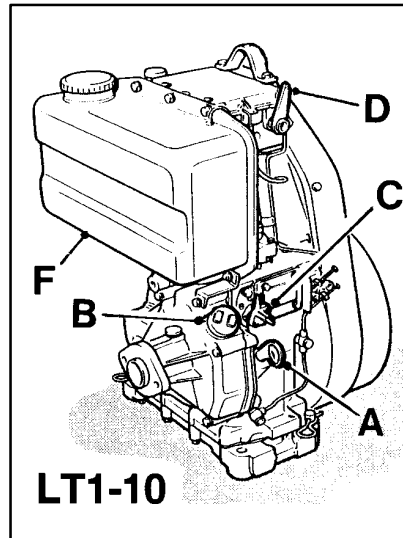
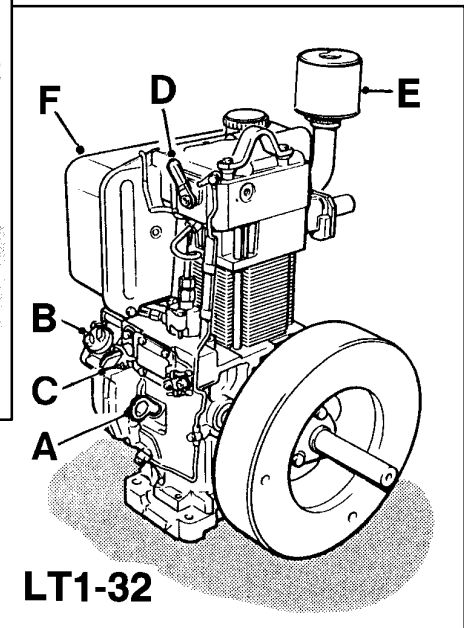
**LT1-10****LT1-32****The cold start aid (where fitted)**

The cold start aid is fitted to the combustion air intake port and is used when the ambient temperature is below  $-10$  deg.C ( $14$  deg.F).

With the fuel turned on, turn the engine for up to 20 revolutions to prime the fuel and lubrication systems.

Withdraw the plunger (A) and fill one third of the cup (B) with the same type of lubricating oil as used in the engine

Replace the plunger and inject the oil just before starting the engine

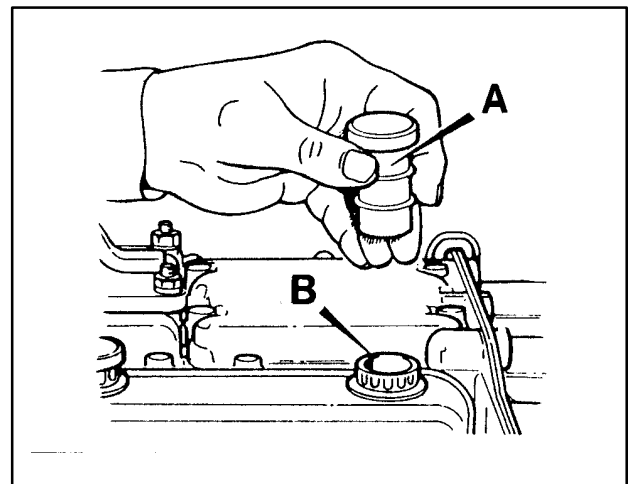

**WARNING** *The device must not be used more than three times in succession during the same attempt to start the engine.*

**The starting handle(s)**

A non-limited kick-back handle (C) or limited kick-back handle (D) system may be fitted to the engine.

The two handles are not interchangeable and care must be taken to ensure the correct type is retained with the engine.

Always use the correct starting handle which has been designed for the engine.

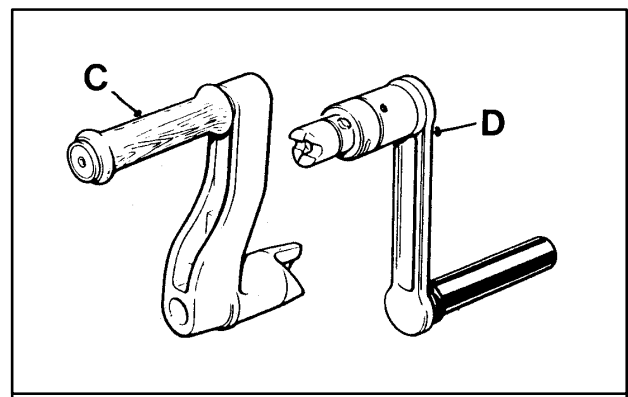

Ensure there are no burrs on the handle.

Before attempting to use the handle, clean and lightly oil that part of it which fits onto the engine.

### Hand starting the engine

Select the excess fuel position by gently pulling the engine control lever (**L**) outward over the middle catch (**M**) and turning it fully clockwise.

Move the decompressor lever towards the flywheel (**N**).

Insert the correct handle (See: 'Starting handles') into the starting housing.

Turn the engine slowly for up to 20 turns to prime the combustion chamber and lubricating oil system.

Maintaining a firm grip on the starting handle, crank the engine really fast and when sufficient speed is obtained move the decompressor lever towards the gear end and continue to crank until the engine fires.

Retain a firm grip on the handle and remove it from the engine.

Close the engine lid and ensure that it stays closed while the engine is running.

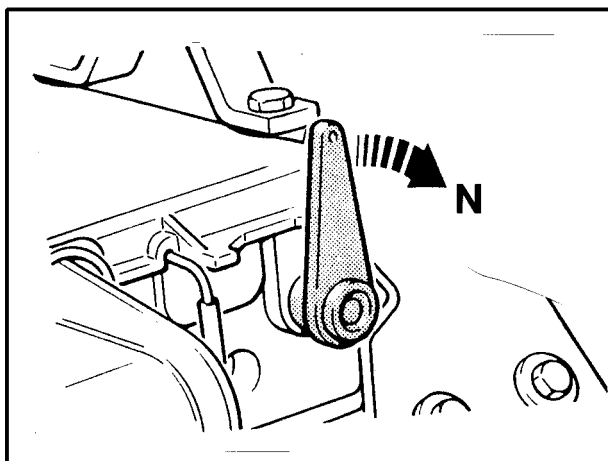
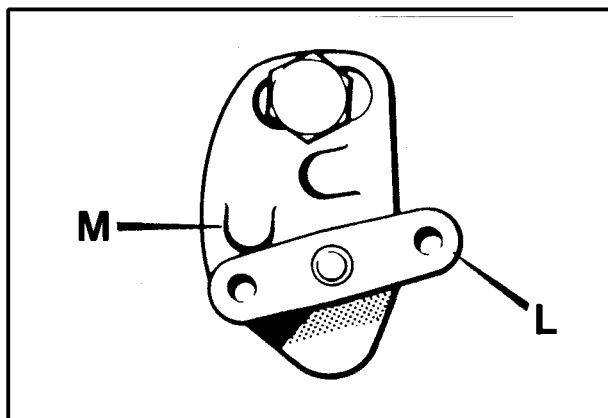

**WARNING** *Do not stop the engine with a load in the drum.*



### Stopping the engine

Turn the engine control anti-clockwise to the STOP position and hold it there until the engine comes to rest.

**WARNING** *Never stop the engine by using the decompressor lever, or valve damage may occur.*



### AC1-05 engine (Electric start with key)

#### Description

- A Oil filler
- B Engine control
- C Air cleaner
- D Fuel tank
- E Key switch
- F Dipstick

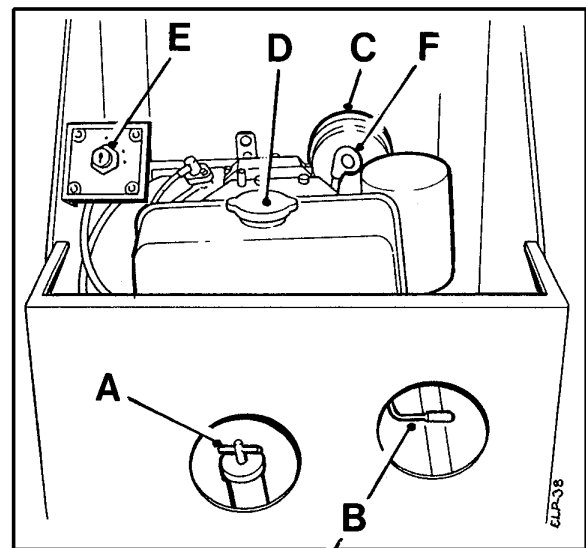

#### Starting the engine

Pull the lever **(B)** towards you. This will move the engine control anti-clockwise into the RUN position.

Turn the start key clockwise **(G)** and release immediately the engine fires.

Do not operate the start key for more than 20 seconds at a time.

Close the engine lid and ensure that it stays closed while the engine is running.

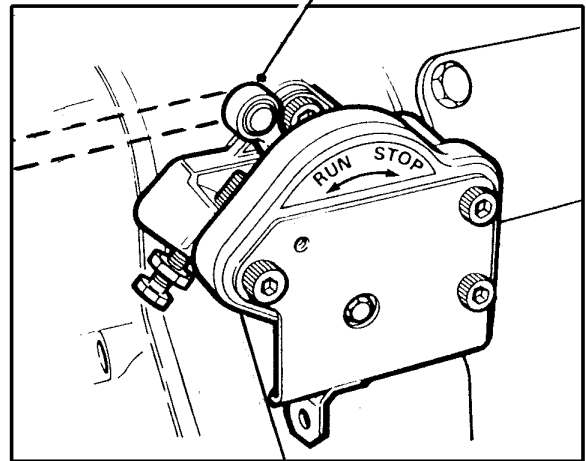

**WARNING** Do not stop the engine with a load in the drum.



#### Stopping the engine

Push lever **(B)** forwards to move the engine control to the STOP position, then wait until the engine comes to rest.

After the engine has stopped ensure the electric start key is switched off.

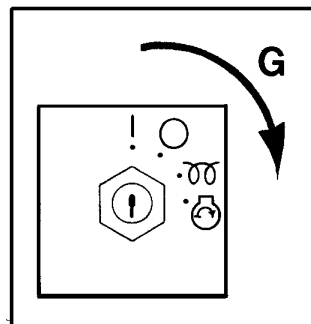

**WARNING** Never stop the engine by using the decompressor lever, or valve damage may occur.





## Yanmar L40/L48

### Description

- A Fuel cock
- B Engine speed lever
- E Starting key

### Electric starting the engine

Open the fuel cock (A). Put the engine start lever to the RUN position (B).

Turn the starting key (E) clockwise to START position.

Remove your hand from the key as soon as the engine starts.

If the engine does not start after 10 seconds, wait a while (for about 15 seconds) before attempting to start again.

**WARNING** *If the starting motor is turned for too long, the battery will go flat and motor seizure will occur. Always leave the starting key turned on, in the ON position, while the engine is running.*



*Check monthly that the battery fluid is at the correct level.*

### Cold Starting

In cold weather, if the engine is hard to start, remove the rubber plug of the rocker arm cover and add 2cc of engine oil before starting. *Do not add more than 2cc of engine oil to prevent internal engine damage.*

**WARNING** *Never use any cold starting aids such as ether (Easy start), gasoline, paint ether or other volatile liquid or gas.*



*Keep the rubber plug in the cover except when adding oil.*

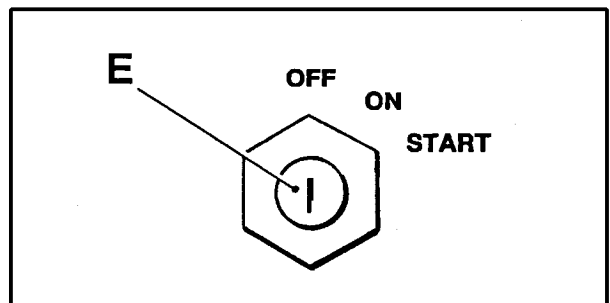
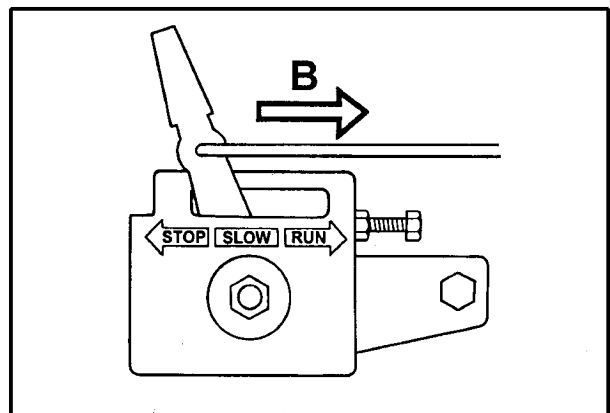
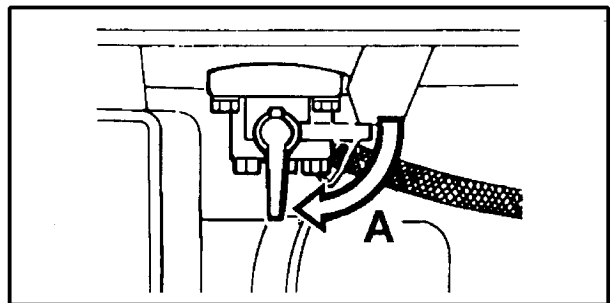
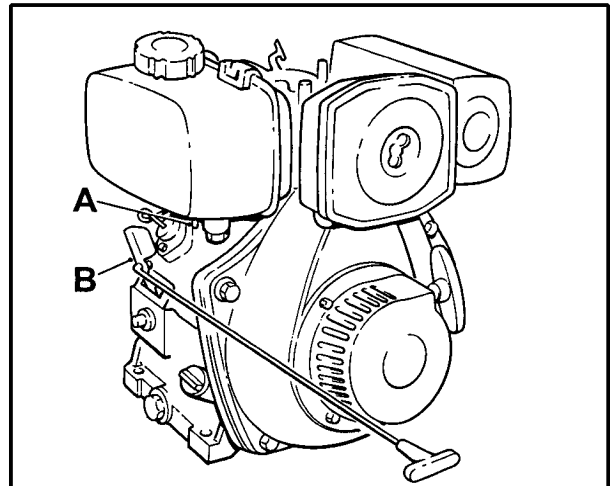

*If the plug is not in place, rain, dirt and other contaminants may enter the engine and cause accelerated wear of internal parts.*

## Yanmar L40/L48

### Stopping the engine

Before stopping the engine, move the engine speed lever to SLOW speed, and run the engine for about 3 minutes with no load.

Return the engine speed lever to the STOP position.

With electric-start engines, turn the starter key to the OFF position.

Set the fuel cock lever to the CLOSED position.

Slowly pull out the recoil handle until pressure is felt (that is, to the point in the compression stroke where the intake and exhaust valves are closed), and leave the handle in this position. This prevents rust from forming while the engine is not in use.

#### WARNING



*If the engine keeps on running even after the speed lever is placed at STOP position, stop the engine by closing the fuel cock.*

*When stopping the engine, reduce the load slowly. Do not stop the engine suddenly since it may cause the temperature to rise abnormally.*

*Do not stop the engine with the decompression lever.*

## Yanmar L40/L48

### Manual starting in the event of a flat battery

#### Description

- A Fuel cock
- B Engine speed lever
- C Decompression lever
- D Recoil starting handle

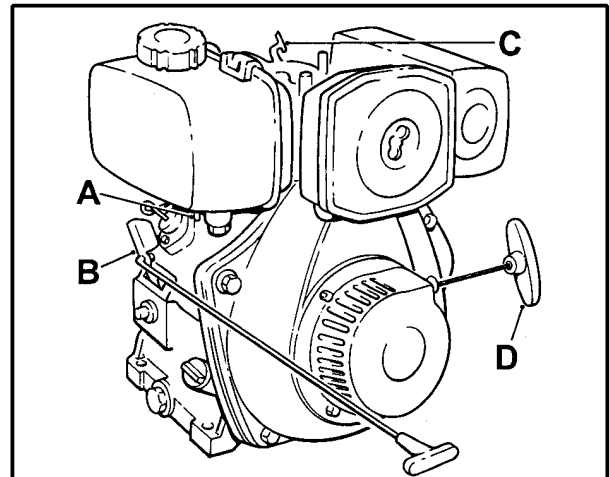

#### Starting the engine

Open the fuel cock (A).

Put the engine start lever to the RUN position (B).

Turn the start key to ON.

Pull out the recoil starting handle (D) slowly until you feel a strong resistance, then return it to the initial position.

Push down the decompression lever (C). It will return automatically when the recoil starter is pulled.

Grip the recoil starting handle (D) firmly with both hands. Pull the rope hard and fast. Pull it all the way out.

The engine should now have started. If it has not, repeat the procedure.

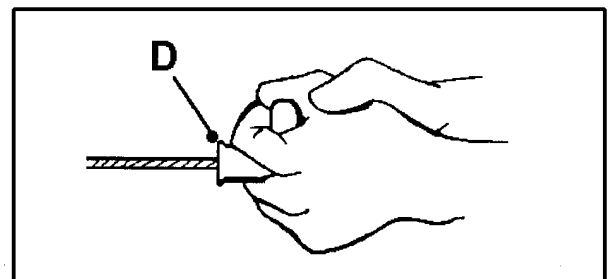
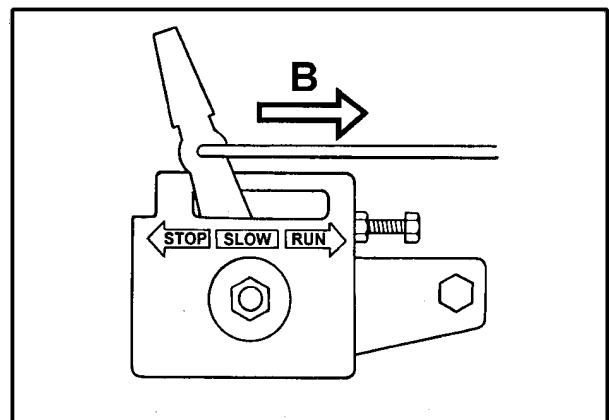
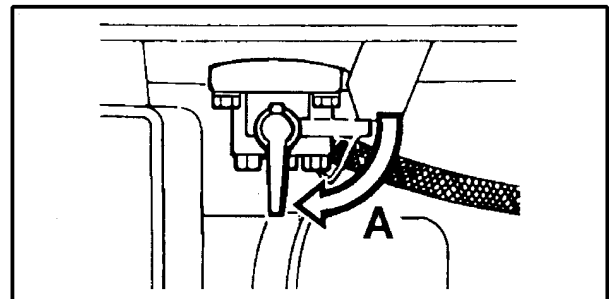

#### Cold Starting

In cold weather, if the engine is hard to start, use the same cold start procedure as described on page 2.5.

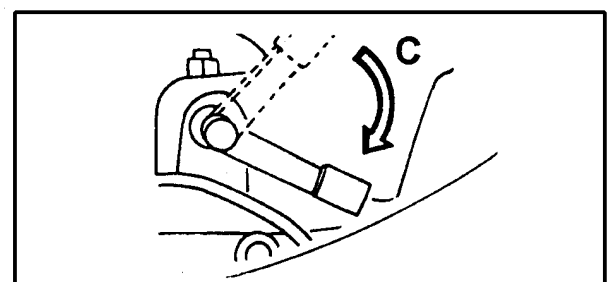

## Honda

*The following engine operating instructions should be read in conjunction with the Honda Owner's Manual.*

### Starting the engine

Turn the fuel valve to the **ON** position.

Move the choke lever to the **CLOSED** position.

*Do not use the choke if the engine is warm or the air temperature is high.*

Turn the engine switch to the **ON** position.

Pull the starter grip lightly until resistance is felt, then pull briskly.

*Do not allow the starter grip to snap back. Return it gently to prevent damage to the starter.*

**Note:** There is no throttle adjustment. The engine speed is set at the factory and there should be no attempt to change it.

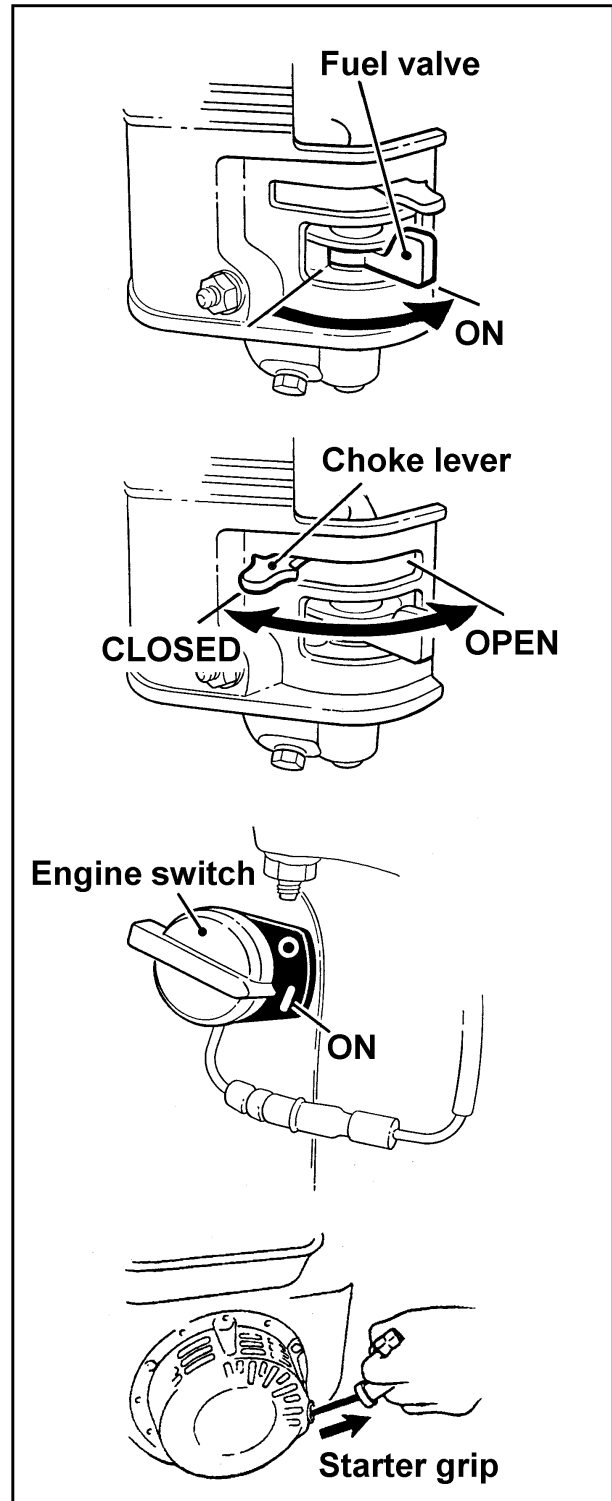

**Stopping the engine**

To stop the engine, turn the engine switch to the **OFF** position.

Turn the fuel valve to the **OFF** position.

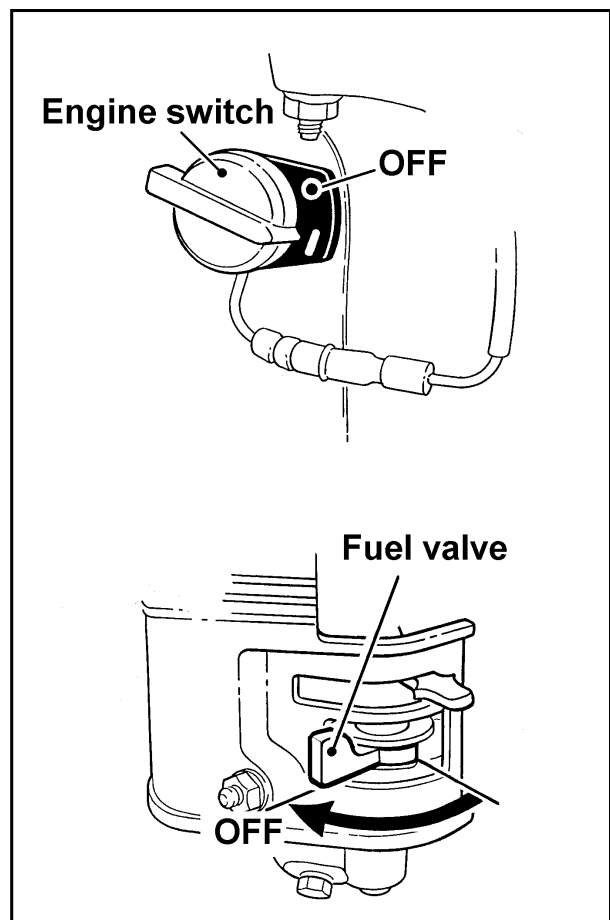

## 2.10

## OPERATION

### Electric motors

#### To start and stop:

Gain access to start button by raising the motor cover (50).

Start the motor by pressing button (51). Lower the motor cover (50).

To stop the motor, press button (52). (Pressing button (53) will also stop it.)

**WARNING** In an EMERGENCY, press button (52) to stop the motor.



Pressing buttons (52) or (53) will not isolate the mixer from the mains.

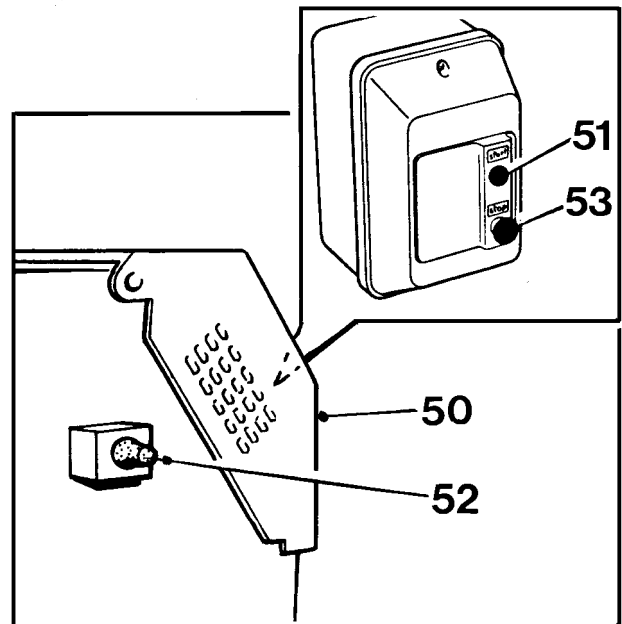

### Before mixing

The operator must calculate the correct percentages of water and aggregates to be mixed.

**WARNING** Cements can cause skin irritation; wear protective clothing.



### Mixer drum positions

The locking plunger (54) holds the mixing drum in one of the following positions *Charge and Mix (1)* or *Discharge (2)*.

**To release the handwheel:** Rotate the plunger (A) until the cross-pin (B) aligns with the slot (C), then pull the plunger outwards (D).

**To lock the handwheel:** Align the plunger with the appropriate hole in the frame, then push (E) and rotate the plunger until the cross-pin is vertical (F).

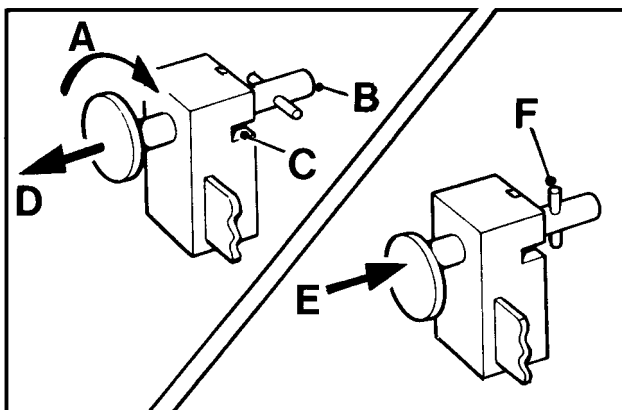
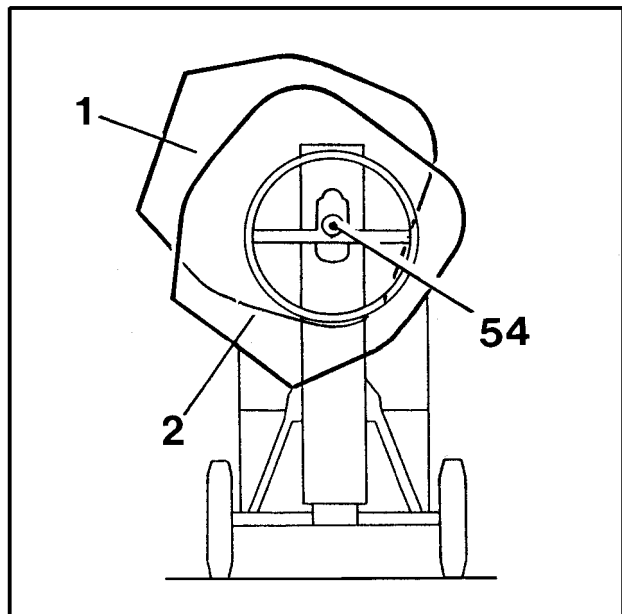

### Mixing

Turn the drum to *Charge and Mix* position (1).

With the mixer running; charge the drum with the correct percentages of water and aggregates, then allow mixing to continue for about two minutes.

Ensure that a suitable container has been positioned by the side of the mixer to catch the discharging load.

Turn the drum to *Discharge (2)*, and allow the load to run into the container.

### **Rotation of the drum**

Looking at the mouth of the drum, all of the engines and motors drive the drum in a clockwise direction. The only exception is the Honda engine that drives the drum anti-clockwise.

### **At the end of the working day**

- A** Thoroughly clean out the mixing drum with water and gravel.
- B** Stop engine, and remove the starting handle to prevent unauthorised use of the machine.
- C** Grease the machine.
- D** If the mixer has a diesel engine, fill the fuel tank.
- E** If the mixer has an electric motor, it must be isolated from the mains.

**INSTALLING/REMOVING THE LIGHTING BOARD (WHERE FITTED)**

Where a lighting board is supplied with the Mixer, follow the procedure below to install and remove the lighting board when preparing for road towing or for use on site.

The board locates on the rear lower panel of the mixer and is secured by two threaded wing nuts.

To attach, locate the threaded studs on the rear of the board into the two holes in the rear lower panel. Secure in place using the wing nuts hand tightening until the board is secure.

The lighting cable should pass through the engine housing wrap around the mainframe centre section and drawbar before being plugged into the towing vehicles trailer lighting socket.

To remove, unplug the lighting cable from the towing vehicle. Unwrap the lighting cable and pass back through the engine housing. Remove the two wing nuts and lift the board clear of the mixer. Store safely until required.



## SERVICE SCHEDULE

(See also the relevant Engine Workshop Manual)

**IMPORTANT!**  
For servicing the Yanmar and Honda engines, see the engine Operation Manual

<b>Every day</b>	
Links & hinges:	Lubricate.
Shafts & bearings:	Lubricate.
Engine: (see <i>Engine Manual</i> )	Check fuel and lubricating oil levels. Check for oil and fuel leaks. Clean/replace air cleaner element under very dusty conditions

<b>Every week (or 50 hours running) <i>The above and following items</i></b>	
Nuts, bolts and keys.	Tighten ( <i>Each week for first month</i> ):
Drive chains & belts:	Lubricate & check tension, check V belt tension on ES engines.
Drum Bevel Gears:	Lubricate with open gear fluid.

<b>Every 125 hours. <i>The above and following items</i></b>	
Engine:	Clean/replace air cleaner element under moderately dusty conditions.
Battery ( <i>where fitted</i> ):	Check condition.

<b>Every 250 hours. <i>The above and following items</i></b>	
Nuts, bolts & keys:	Tighten.
Engine:	Change lubricating oil. (and filter on AC1 engines only). Check valve clearance. ( <i>see Engine Manual</i> ). Clean/replace injectors if exhaust is dirty. ( <i>see Engine Manual</i> ). Renew fuel filter element if the fuel is not perfectly clean.

<b>Every 500 hours. <i>The above and following items</i></b>	
Engine:	Replace air cleaner element. Check exhaust and induction for leaks, damage or restrictions. Renew fuel filter element. Check battery charge winding system. ( <i>see Engine Manual</i> ).

<b>Every 1000 hours. <i>The above and following items</i></b>	
Engine: (see <i>Engine Manual</i> )	Decarbonise if the engine performance has deteriorated. Clean cylinder barrel and head fins. Clean restrictor banjo union at the cylinder head end of the oil feed pipe. Flush and refill fuel tank.

<b>Every 5000 hours. <i>The above and following items</i></b>	
Engine:	Major overhaul, if necessary. ( <i>see Engine Manual</i> )

## SERVICING PROCEDURE

### Greasing and lubrication

**WARNING** *It is essential that oils and grease used for servicing do not become contaminated with sand or cement dust.*



#### Every day

Apply a little engine oil to pins, joints and hinges etc. to ensure that they move easily and are free from corrosion.

Shafts and bearings fitted with grease nipples must be greased using a good quality medium grease.

Bearings must not be allowed to run dry. When greasing it is better to give a little frequently rather than a lot at long intervals.

#### Lubrication Points

<b>A</b>	Drive chains:	<i>Oil</i>
<b>B</b>	Wheels:	<i>Grease</i>
<b>C</b>	Steering joint:	<i>Oil</i>
<b>D</b>	Locking plunger	<i>Oil</i>

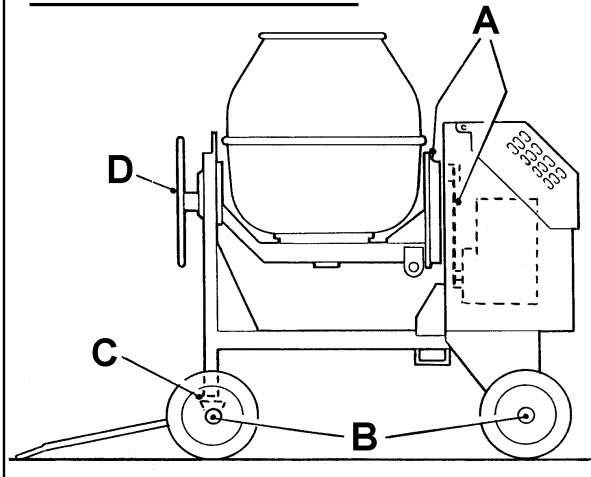

### Drum drives

**Every week (or 50 hours running)**

#### Drive chains:

Lubricate drive chains (**A**) with a little engine oil.

Check the tension of the chains and adjust if necessary as follows:

On the slack side of the chain there should be free movement equal to the length of one pitch of the chain.

i.e. If the pitch of the chain is 20mm, then the movement on the slack side should be 20mm.

Never over-tighten the chain as this will put excessive strain on engine bearings causing vibration and wear.

#### Drive belts:

**WARNING** *NEVER oil belts.*



Check the tension of the belt and adjust if necessary. The belt should deflect no more than 2 to 3 mm using thumb pressure.

Never over-tighten the belt as this will put excessive strain on engine bearings causing vibration and wear.

## Bolt torques

Every week for the first month, then every three months

Check the tightness of all bolts, nuts, and keys etc. Pay particular attention to engine mounting bolts.

## Engine, general servicing

Under very dusty conditions, air cleaners, lubricating oil and fuel filters will require more frequent attention. (see the "Service Schedule" on page 3. 1)

**WARNING** *The materials used in the manufacture and treatment of some filters and elements may cause irritation or discomfort if they come into contact with the eyes or mouth and they may give off toxic gases if they are burnt.*



## Air cleaner

Every day or 125 hours (see schedule)

Change the Air Cleaner as follows:

### L T/LV1-32 engines

Slacken the clip (A)

Remove the cleaner (B) from the manifold (C).

Fit a new cleaner assembly.

### LT/LV1-10 engines

Remove the cover (D) by removing the centre bolt.

Remove the old element (E) and fit a new one.

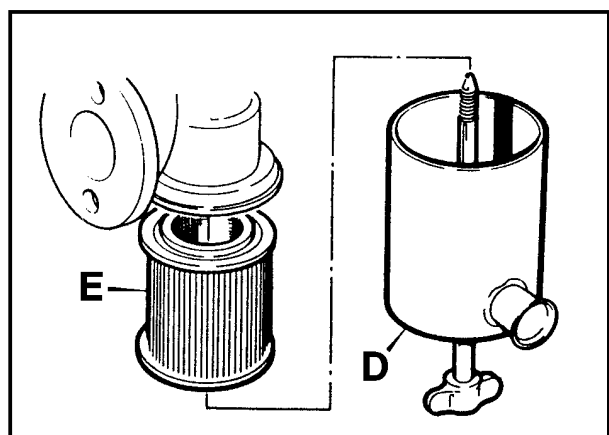
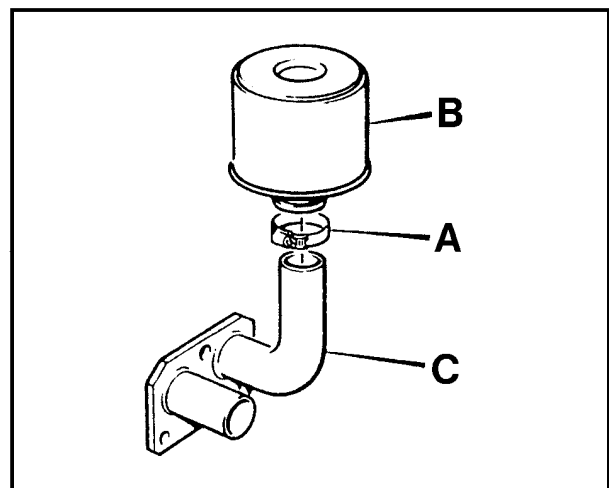

**AC1-05 engines**

Release the clips (**F**) and lift off the cover (**G**). Remove the element (**H**) from the cleaner body.

Clean the cleaner body and cover (**G**) of all dust.

Fit a new element and joint if necessary.

Replace the cover (**G**).

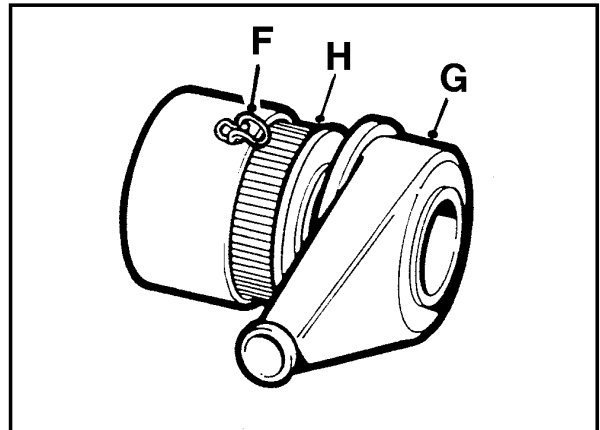
**ENGINE LUBRICATION OIL****Every day**

Check lubrication oil level with the dipstick. Top up if necessary.

**Every 250 hours**

**Drain and refill the oil sump (also on AC1 engines replace oil filter) as follows:**

**WARNING**

*Dispose of waste oil into waste oil storage tanks. If storage tanks are not available, consult your Distributor or local authority for addresses of local designated disposal points. It is illegal to dispose of waste oil into drains or water courses, or to bury it.*

*Oils and fuels can cause skin irritation. Wear suitable protective clothing to prevent skin contact.*

If possible run the engine immediately before draining the oil.

**Note:** During 2003 the metal drain pipe (**B**) was replaced by a flexible drain hose (*not illustrated*).

Place a suitable container under the drain plug. Remove the drain plug (**A**) and drain oil.

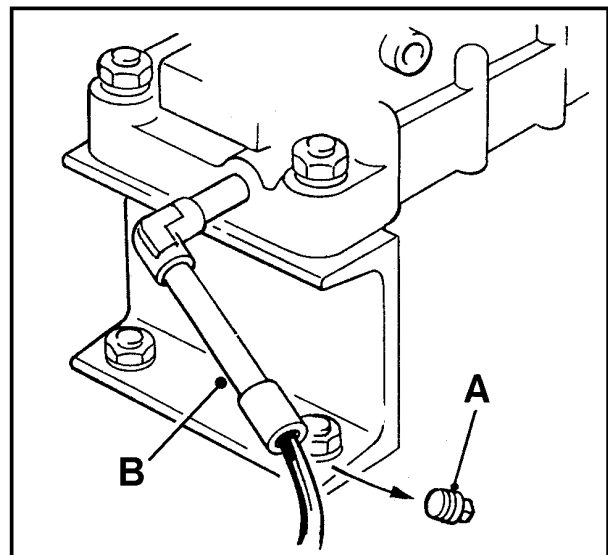

Clean and coat the threads of the drain plug with Hylomar PL32/M or Three Bond 1110B.

Replace the drain plug (**A**) taking care not to overtighten it.

## AC1-05 engines only

### Change oil filter as follows:

The oil filter is mounted inside the crankcase at the gear end and consists of a detachable cover containing the element which is secured by a centre bolt into the crankcase.

Unscrew the centre bolt (C) and withdraw the filter cover (D) and the element (E).

Clean the cover and chamber.

**Do not attempt to clean the old filter element. Dispose of it safely.**

If necessary fit new seal (F).

Fit a new element into the crankcase and replace the cover.

Tighten the centre bolt to a maximum torque loading of 13.6Nm (10.0lbf ft).

Fill the sump through the oil filler to the top mark on the dipstick (B).

Start the engine, run it for a few minutes and check the drain plug does not leak.

Stop the engine, allow the oil to settle and check the level on the dipstick. Add more oil if necessary.

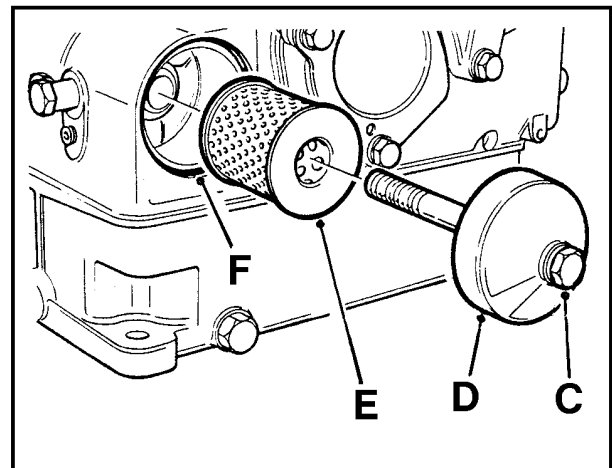

## Fuel filter

Every 250 hours or 500 hours (see schedule)

**Before changing the filter read the warnings in the "Safe working" section of this handbook.**

### Change LT/LV1 fuel filters as follows:

Remove the retaining bolt or plug (H).

Remove the old element (I) and joints (J).

Fit a new element and new joints.

Replace and tighten the retaining bolt or plug (H).

Prime the fuel system.

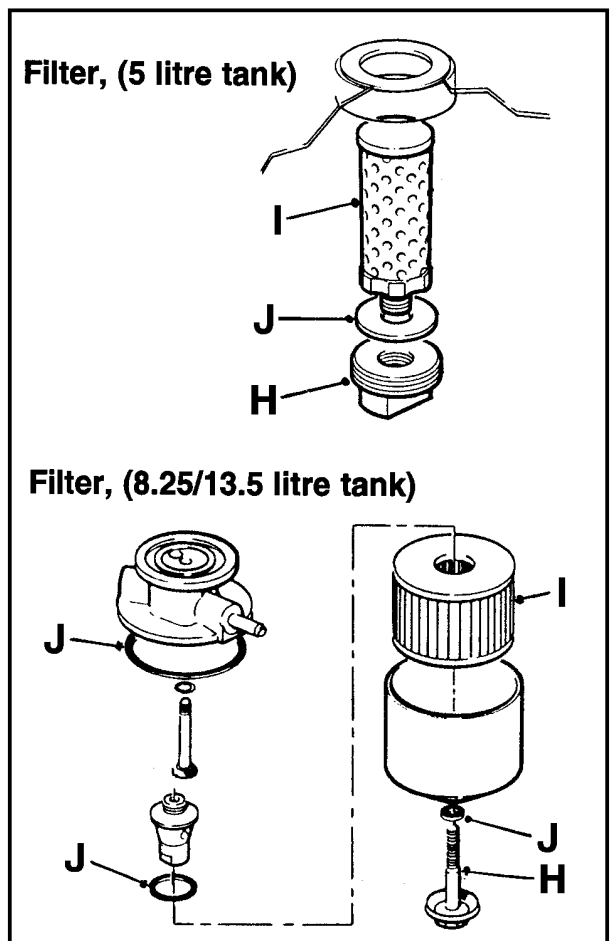

**Prime LT/LV1 fuel system as follows:**

Fill the fuel tank.

Move the engine control lever to the 'RUN' position.

Vent the filter through bleed screw (G) until a full air free flow of fuel is obtained.

Vent fuel through the pump bleed screw (K) until a full air free flow of fuel is obtained.

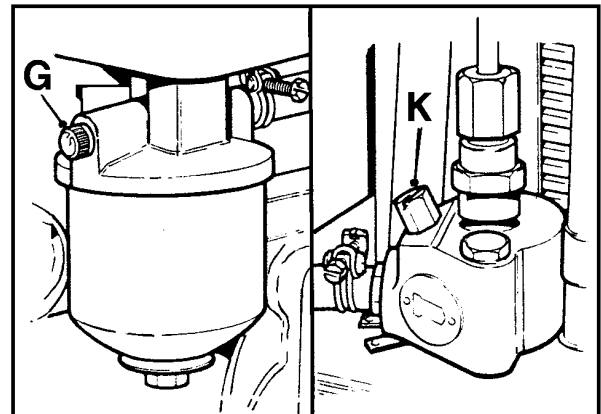
**Change AC1-05 fuel filters as follows:***Tank mounted filter*

**Care should be taken to ensure the jubilee clip fitted to polypropylene fuel tanks is not slackened or removed.**

Remove the fuel pipe from the tank and drain the tank.

Unscrew the plug (L) from the tank and remove the plug and element from the bottom of the tank.

Unscrew the element (M) from the plug and discard it.

Discard the joint (N).

Fit a new joint over the element screw spigot.

Screw the new element onto the plug; **use the nut section of the element only.**

Screw the plug and element into the bottom of the tank.

Replace the fuel pipe.

Fill the fuel tank and, if necessary, prime the fuel system.

**Note:** *The fuel system fitted to the AC11 engine is self priming, however in some instances it may be necessary to assist with priming as follows:*

Pull the rubber leak-off pipe (O) away from the fuel pump (P) to allow air to escape.

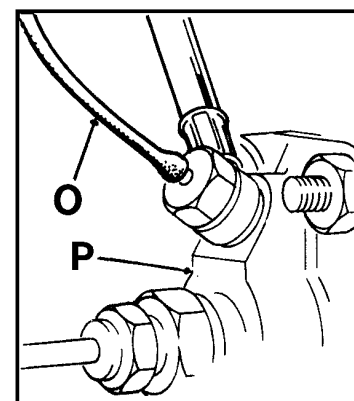
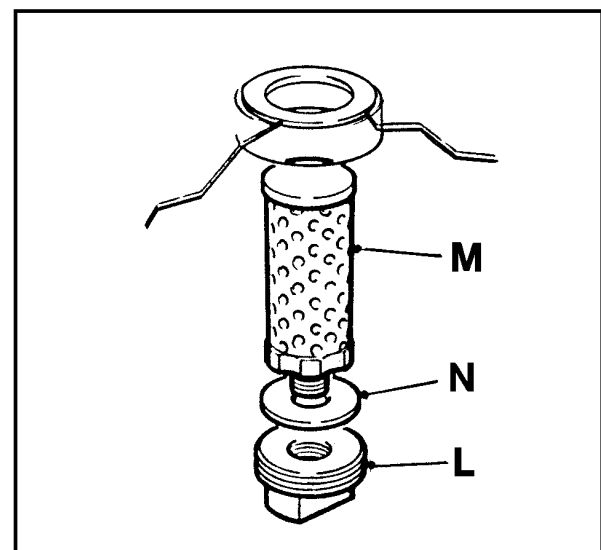

When no air bubbles are escaping push the rubber hose **(0)** back onto the fuel pump.

Crank the engine until the injector is heard to 'squeak'.

## **BATTERY**

### **WARNING**



*BATTERIES CONTAIN  
SULPHURIC ACID WHICH  
CAN CAUSE SEVERE  
BURNS AND PRODUCE  
EXPLOSIVE GASES.*

*If the acid has been splashed  
on the skin, eyes or clothes  
flush with copious amounts of  
fresh water and seek  
immediate medical aid.*

Check the battery as follows:

Wear protective gloves and goggles.

Clean the top of the battery filler plug area.

Remove the filler plugs and check that the electrolyte level is 6.0-9.0mm (0.25-0.37in) above the tops of the separators.

If necessary top up with distilled water.

In cold weather distilled water should only be added immediately before running the engine.

Replace and tighten the filler plugs.

Check that the terminal connections are tight; petroleum jelly will help to protect them from corrosion

### Mixer drum assembly

The drum is manufactured in two halves joined together by a drum clip. This allows either half to be replaced separately.

Some export machines are delivered with the drum cone and blades detached. This is to aid shipping.

There are two methods of reassembling the two halves of the drum, they are:

#### 1 Assembling drum using special clamping tool.

*(The special clamping tool, part number 513204000 can be obtained from any Winget distributor.)*

- A** Bolt the two blades into the drum base **(1)**. Tighten the bolts with fingers only.
- B** Smear silicone sealant around the mating flanges of the cone **(2)** and drum base **(3)**. (see 'Specifications' for mixer drum sealant)

**WARNING** *When applying silicone sealer, prevent contact with skin by wearing suitable gloves.*



- C** Lift the cone **(2)** over the blades and position it on the drum base **(3)**.
- D** Turn the cone until the two holes at the top of each blade **(4)** align with the holes in the cone. Fit bolts and tighten with fingers only.
- E** Smear silicone sealant around the inside face of the drum clip **(5)** (leave 150mm each end of the clip clear of sealant to avoid risk of fire when welding).
- F** Locate the drum clip around the periphery of the drum base and cone flange.

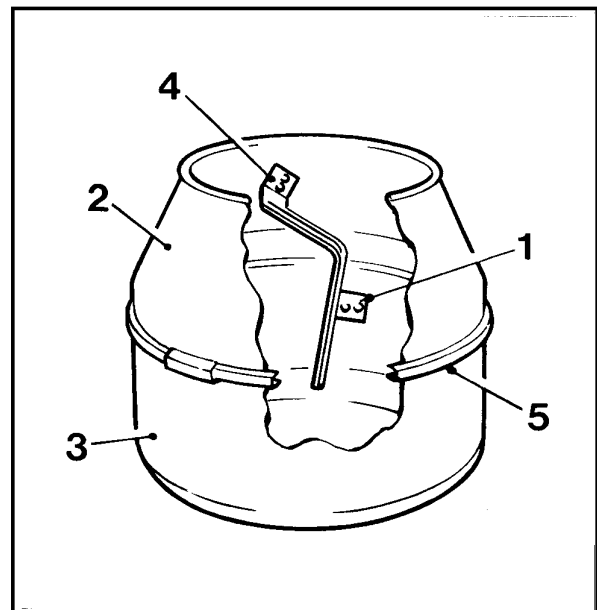



- G** Locate the clamping tool (7) into the two holes (8) of the drum clip. Tighten the tool securely using a suitable spanner.
- H** Centralise the bridge piece (9) on the drum clip between the jaws of the clamping tool.
- I** Weld the bridge piece (9) to the drum clip (5). Remove the clamping tool (7).
- J** Tighten securely all of the blade fixing bolts.

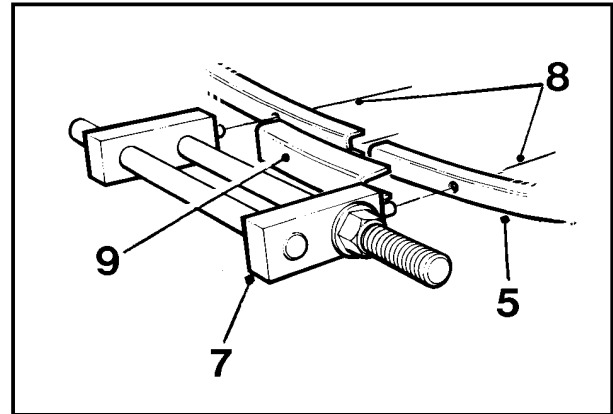

## 2 Assembling drum using a tourniquet.

- A** If the special clamping tool is not available a tourniquet can be used as illustrated by looping a length of rope through four blocks of wood (10), each block having a vee cut, and two holes to take the rope.
- B** Twist the rope around a bar (11) to tighten the drum clip.
- C** All other aspects of the assembly are the same as "Assembling the drum using special clamping tool".

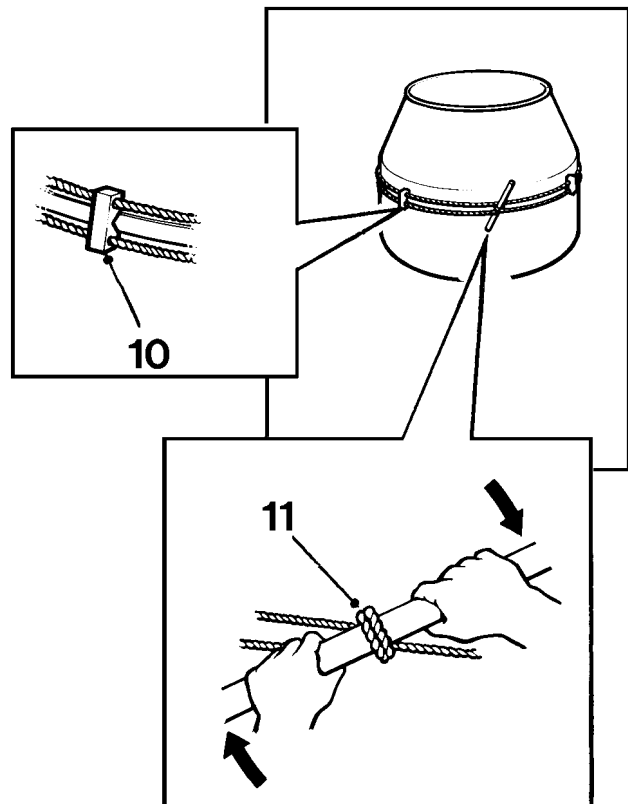

### Mixer drum drive overhaul

On reassembling the drum drive, after an overhaul, the following points must be observed:

- A** Coat with an anti-seize compound the drum shaft (**j**) at points (**a**), and the screws (**j1**)
- B** The bearings (**b**) on either end of the bevel pinion shaft (**d**) are sealed for life and therefore require no maintenance.
- C** The bevel gears (**c**) are to be coated liberally with Open Gear Fluid.

**D** The bevel pinion assembly (**d**) must be set horizontally in the trunnion. Do this as follows:

Ensure that the drive chain (**f**) is correctly adjusted, then set the bevel pinion assembly (**d**) horizontal by adjusting shims (**e**).

**E** To adjust the mesh of the bevel pinion gears proceed as follows:

Allow the bevel gear to sit fully in mesh with the bevel pinion. Check the number of washers required to fill the gap (**g**) between the drum shaft flange and the trunnion face. Remove one washer from each side, fit screws (**h**) and tighten.

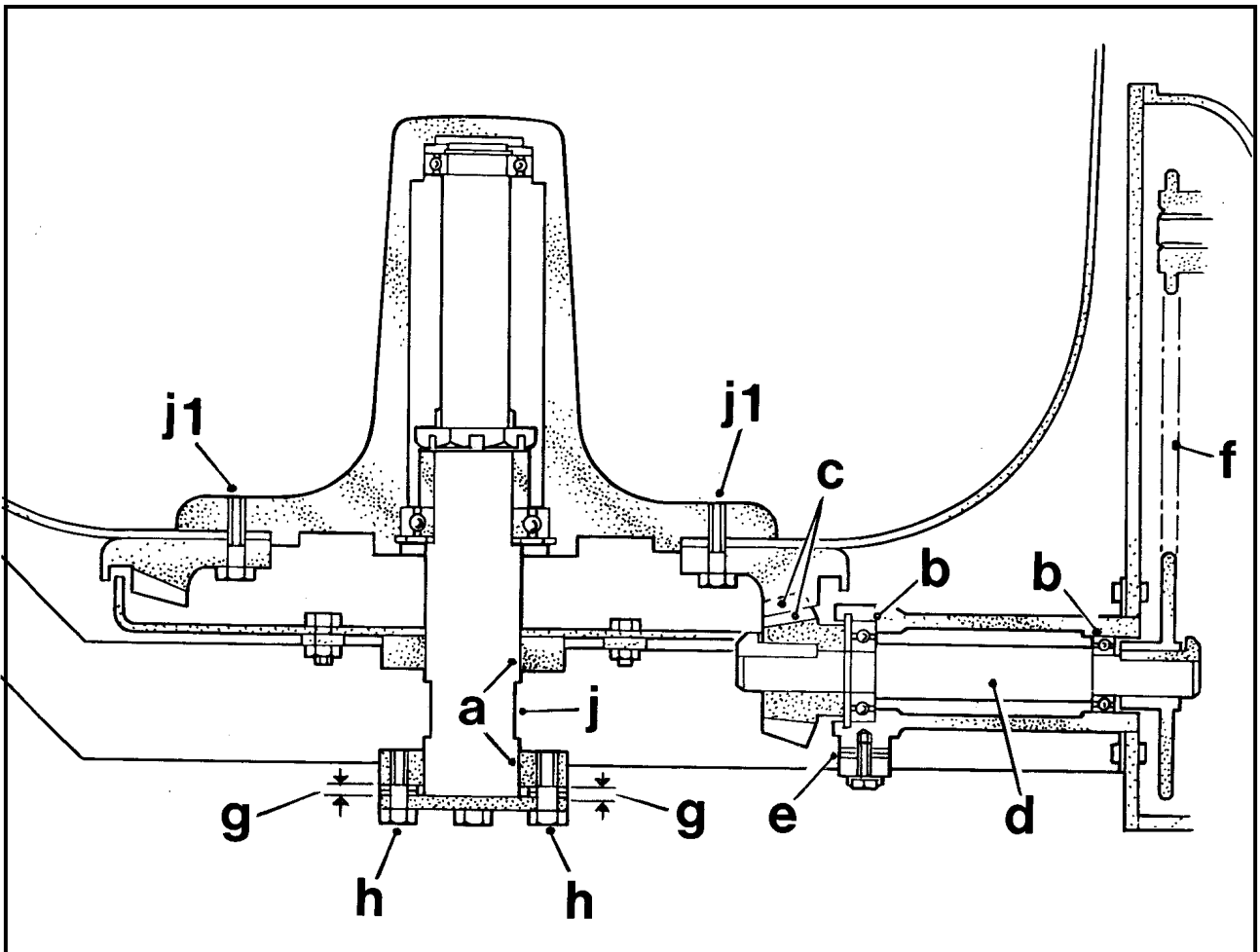

## Suspension Units

### Two wheeled mixers, "Fast tow"

The suspension units require no maintenance as they are a sealed unit. They have an internal construction of rubber rollers and have ends that are sealed with nylon bushes.

**WARNING**

*Do not subject suspension units to excessive heat (such as welding) as this could damage the rubber and nylon components.*

## Tyres

Check the tyres for wear, damage and deterioration.

Check tyre pressures only when the tyres are cold.

*(see "specifications" section for tyre pressures)*

### Before towing your mixer on the road:

Check wheel nuts for tightness.

Check that the wheel bearings have been greased and that the nuts and split pins have been inserted properly on to the ends of the stub axles.

To gain access to the wheel bearings remove the plastic or metal cap from the centre of the wheel. Do this by carefully prizing off the cap with a screwdriver or tapping it with a block of wood.

There are two types of hub bearings:

- 1 The ball race type has a spacer between the bearings. With this hub the nut has to be screwed up very tightly.
- 2 The taper roller type, where the nut must not be over tightened. There must be a small amount of end float (.004"). Usually it is sufficient to tighten the nut up fully, then unscrew it half a turn. Make sure that the split pin is then inserted.



## Lubricants

Mixers are factory filled with the following TOTAL oils

Engine, LT/LV1: lubricating oil	Rubia B 10W/30	1.3 litres
AC1-05: lubricating oil	Rubia B 10W/30	2.7 litres
Yanmar L40/L48: lubricating oil	Rubia B 10W/30	0.8 litre
Honda: lubricating oil	Rubia B 10W/30	0.6 litre
<i>Note: In cold weather engines are to be filled with 10W oil to aid starting</i>		
LT/LV1: fuel		5.0 or 8.25 litres
AC1-05: fuel		5.1 litres
Yanmar L40/L48: fuel		2.5 litres
Honda: fuel		3.6 litres

Electric motor bearing	Multis EP 2
Drive chains	Rubia B 20W/30
Bevel gears	Open gear fluid
Drum shaft	Anti-seize compound
Grease nipples	Multis EP 2
Linkages and hinges	Rubia B 20W/30

**Noise levels of mixers.** Measured in accordance with EC Directive 2000/14/EC  
**Models 100T, 150T and 175T**

LPA 80	LWA 101	(All engines except Honda)
LPA 85	LWA 101	(Honda only)

## Drum speed

## Handbrake

22 rpm	Tested to hold on a 5° & 10° slope with 600Kg of test weights applied
--------	---

## Tyre pressures

50 lbin <sup>2</sup>	(Two wheeled "Fast tow" mixers)
----------------------	---------------------------------

## Mixer drum sealant

Silicone sealant	(part number V2000772)
------------------	------------------------

## Engines and Motors

	Lister-Petter			Yanmar	Honda	Electric motors
	Standard		Option	Option	Option	Option
	LT/LV1-10 @ 1000 rpm	LT/LV1-32 @ 1000 rpm	AC1-05 @ 1500 rpm	L40 @ 3000 rpm	GX160 @ 2850 rpm	110v or 240v @ 1420 rpm
<b>100T</b>	-----	0.76kW (1hp)	2.05kW (2.75hp)	2.5kW (3.4hp)	3.4kW (4.5hp)	0.75kW (1hp) 240v 1.1kW (1.5hp) 110v
<b>150T</b>	-----	0.76kW (1hp)	2.05kW (2.75hp)	2.5kW (3.4hp)	3.4kW (4.5hp)	1.1kW (1.5hp)
<b>175T</b>	1.9kW (2.5hp)	-----	2.05kW (2.75hp)	2.5kW (3.4hp)	3.4kW (4.5hp)	1.1kW (1.5hp)

DIMENSIONS

Four wheel models

	100T	150T	175T
A	1515	1650	1680
B	1560	1730	1780
C	520	555	520
D	800	800	800
E	400	400	400
F	1000	1100	1110

Weight (approx) LV1 Eng

100T	150T	175T
375kg	425kg	460kg

Weight (approx) L48 Eng

100T	150T	175T
340kg	400kg	420kg

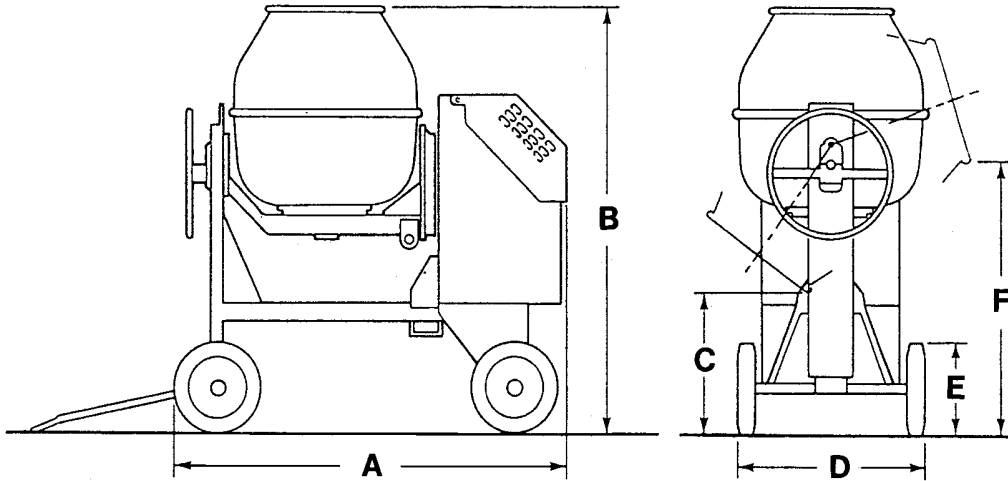

Two wheel models

	100T	150T	175T
A	1805	1890	2060
B	2390	2490	2640
C	1610	1760	1840
D	565	600	590
E	1325	1325	1350
F	4.80/4.00-8	145R10	
G	1035	1140	1180
H	490	490	450

Weight (approx) LV1 Eng

100T	150T	175T
395kg	445kg	500kg

Weight (approx) L48 Eng

100T	150T	175T
365kg	420kg	460kg

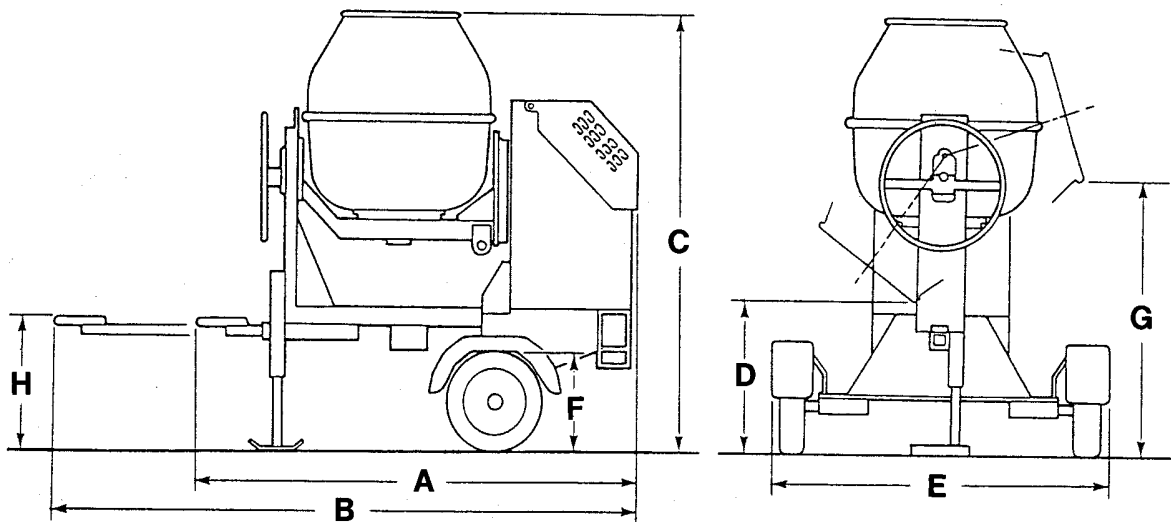

**ELECTRICALLY DRIVEN MIXERS WIRING CIRCUIT**

Electrical connections must only be made by a suitably qualified electrician.

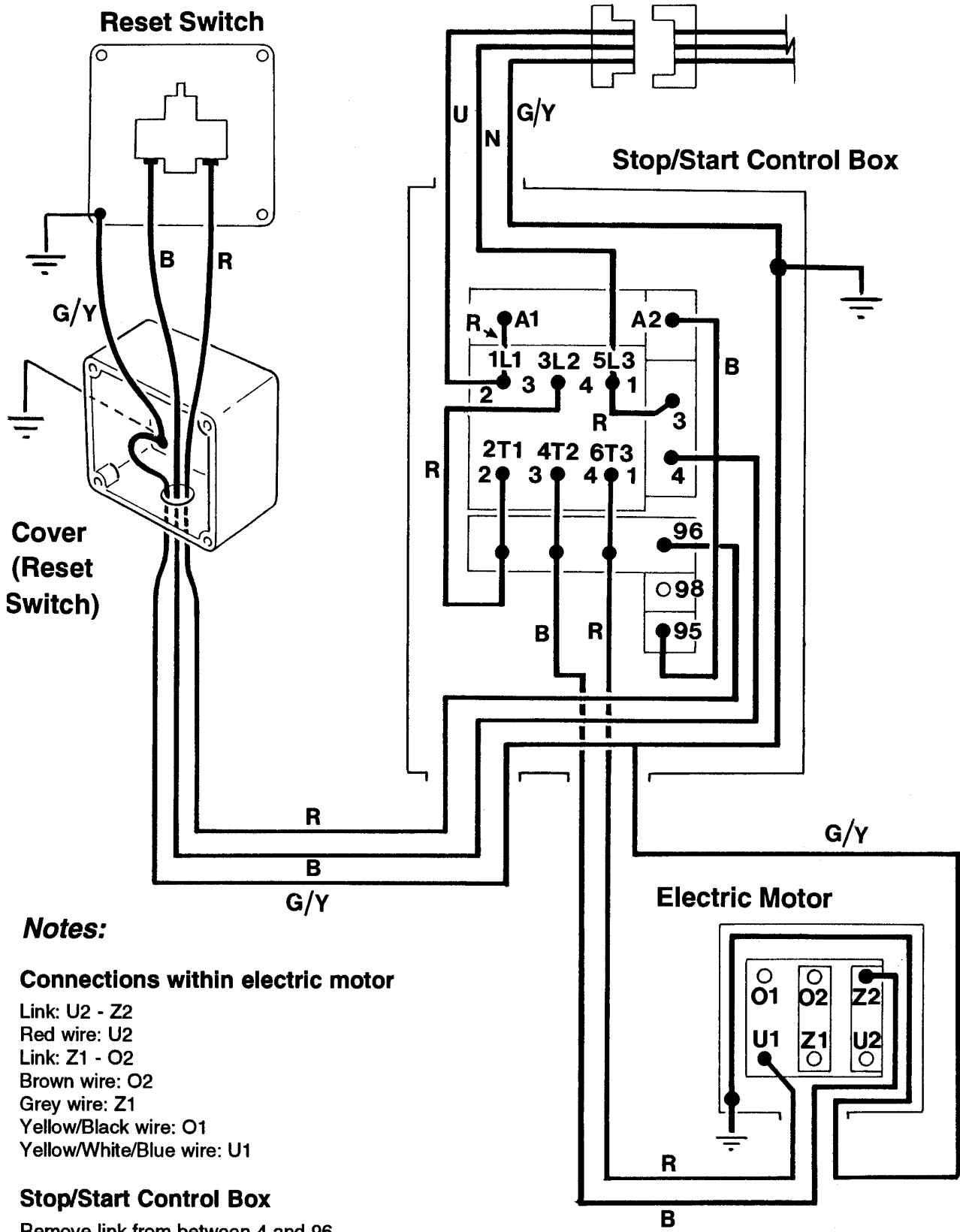

**Notes:**

**Connections within electric motor**

- Link: U2 - Z2
- Red wire: U2
- Link: Z1 - O2
- Brown wire: O2
- Grey wire: Z1
- Yellow/Black wire: O1
- Yellow/White/Blue wire: U1

**Stop/Start Control Box**

Remove link from between 4 and 96

LISTER-PETTER AC1-05 KEY START WIRING CIRCUIT

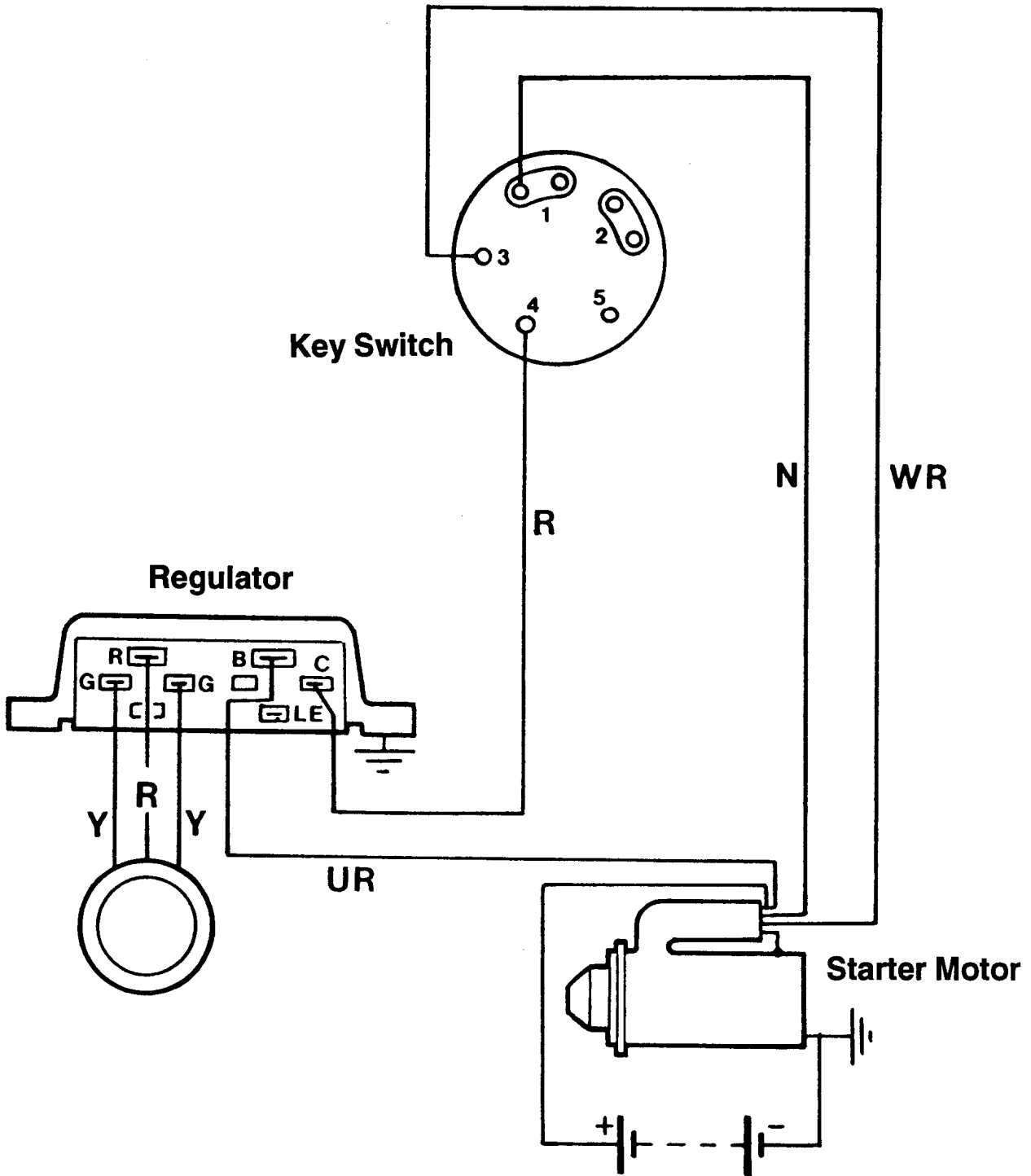



**YANMAR L40/48 KEY START WIRING CIRCUIT**

In addition to the circuit shown below, the engine is fitted with its own loom.  
(see Yanmar service literature)

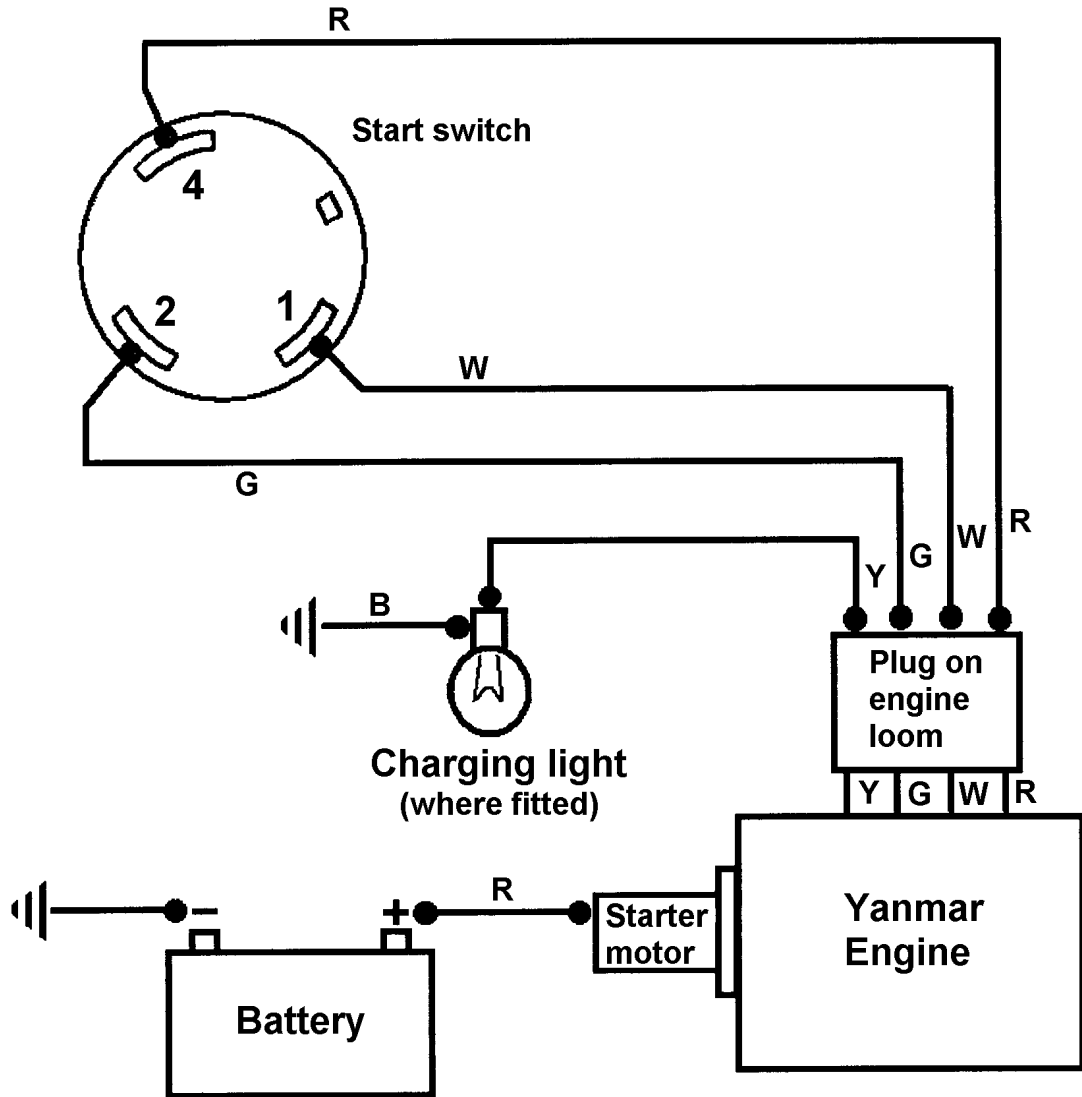

**Wire colours**

- R Red
- B Black
- G Green
- W White
- Y Yellow

**NOTE: Wire identification**

The red wire to the battery is much thicker than the red wire to the start switch.





# **PARTS**

**Mixers built  
UP TO  
February 1988**

**Mixers built  
FROM  
February 1988**

**<<< To front of book**



# Mixers

100T

150T

175T

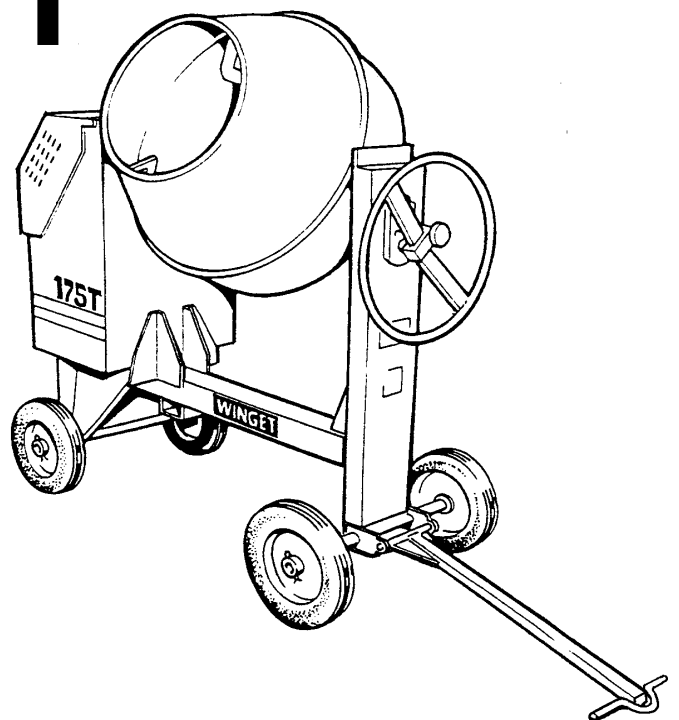
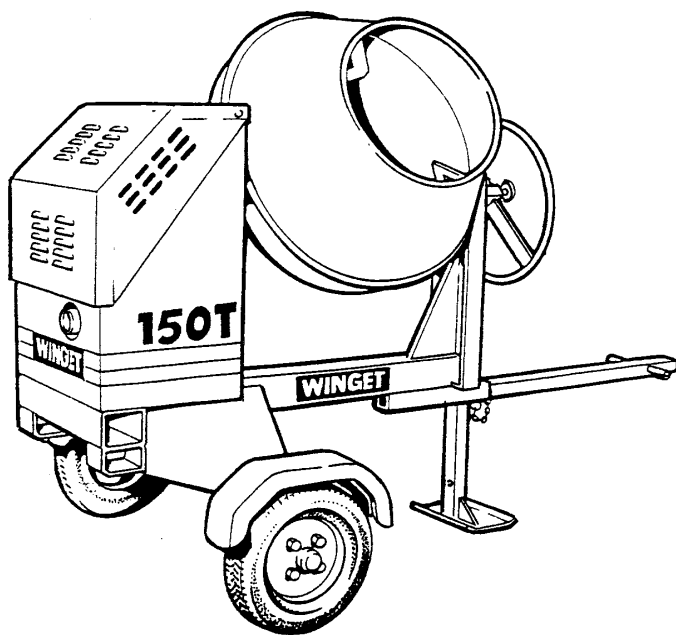

# Mixers built UP TO February 1988

<b>FOUR WHEEL MAINFRAME</b>	<b>A - 1</b>
<b>TWO WHEEL MAINFRAME, slow tow</b>	<b>A - 2</b>
<b>TWO WHEEL MAINFRAME, fast tow</b>	<b>A - 3</b>
<b>DRUM</b>	<b>B - 1A</b>
<b>TRUNNION &amp; TILT WHEEL</b>	<b>B - 1B</b>
<b>DRUM DRIVE</b>	<b>B - 1C</b>
<b>LISTER DRIVE ASSEMBLY</b>	<b>C - 1</b>
<b>PETTER DRIVE ASSEMBLY</b>	<b>C - 2</b>
<b>HATZ DRIVE ASSEMBLY</b>	<b>C - 2A</b>
<b>ELECTRIC CHAIN DRIVE ASSEMBLY</b>	<b>C - 3</b>
<b>ELECTRIC BELT DRIVE ASSEMBLY</b>	<b>C - 4</b>
<b>START SWITCHES (electric belt drive)</b>	<b>C - 5</b>
<b>DECALS &amp; PLATE</b>	<b>D - 1</b>
<b>SPECIAL TOOLS</b>	<b>D - 3</b>
<b>NUMERICAL INDEX, up to February 1988</b>	<b>INDEX</b>





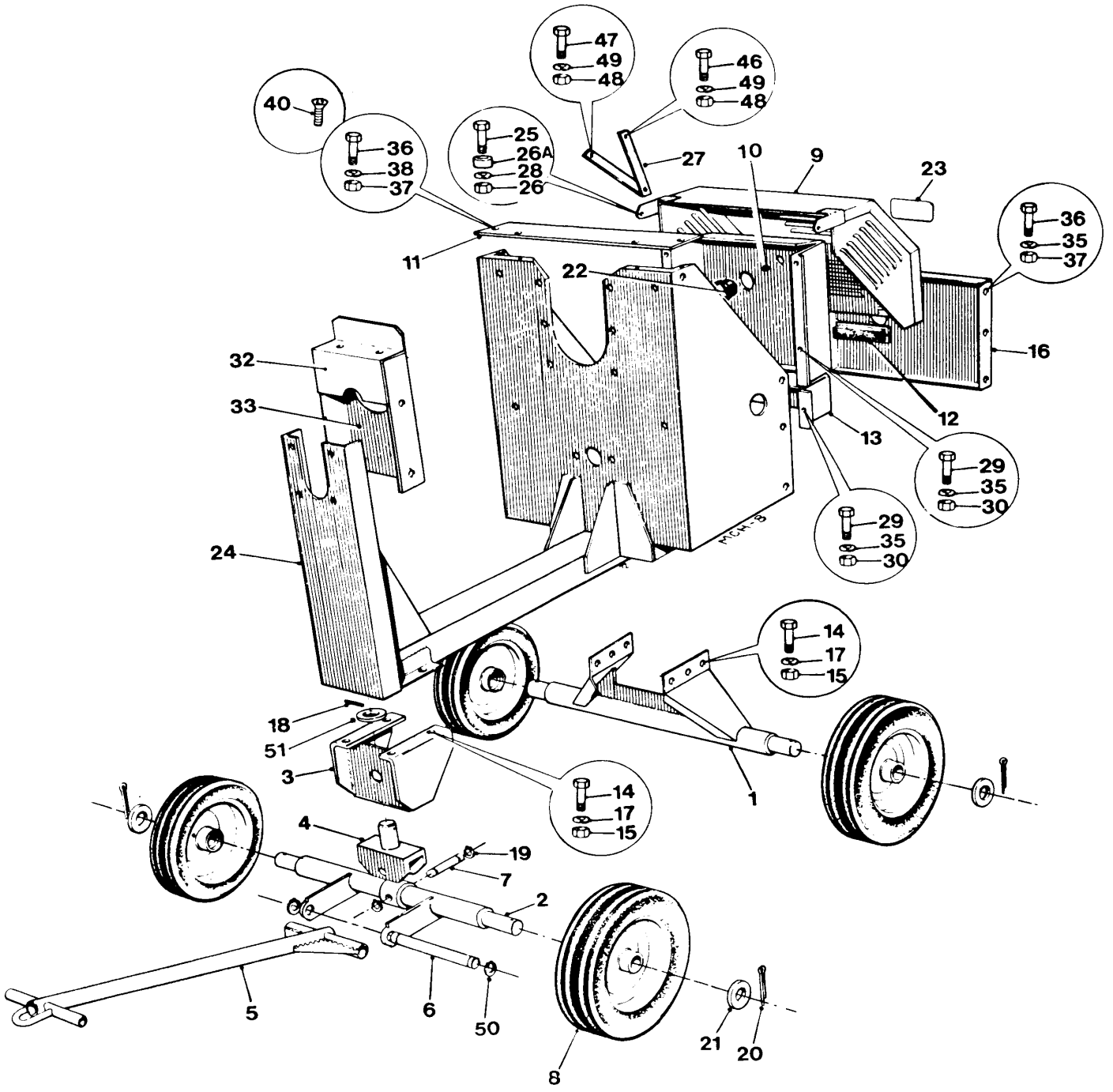

# FOUR WHEEL MAINFRAME & GUARDS

A - 1

Item	Part no	Serial no	Description	Qty
<b>100T</b>				
1	513275100	/ Feb 88	AXLE, rear	1
2	513197900		AXLE, front	1
<b>150T &amp; 175T</b>				
1	513275200	/ Feb 88	AXLE, rear,	1
2	513203400		AXLE, front	1
3	513274900		BRACKET, front axle swivel	1
4	513154500		SWIVEL, front axle	1
5	513154700		TOWBAR	1
6	513154800		PIN, pivot, towbar	1
7	513155000		PIN, pivot, front axle	1
8	475106000		WHEEL, cushion tyred	4
<b>Alternative wheel arrangement</b>				
8	513198500		WHEEL, steel, 16" x 4"	4
9	513286800		LID, engine housing	1
10	513248700		GUARD, chain	1
11	513287000		TOP PLATE, housing	1
12	513205300		STOP, engine housing lid	1
13	513205700		GUARD, sprocket ( <i>Petter AC1ZS</i> )	1
13	513266900		GUARD, sprocket ( <i>Lister LT1</i> )	1
13	513205600		GUARD, sprocket ( <i>Electric 2.23hp</i> )	1
13	513291000		GUARD, 'V' pulley ( <i>Elec. 1hp &amp; 1.5hp</i> )	1
14	69S05E		BOLT	10
15	192S05		NUT	10
<b>100T</b>				
16	513269900		PLATE, closing ( <i>Petter AC1ZS</i> )	1
16	513270000		PLATE, closing ( <i>Lister LT1</i> )	1
16	513270100		PLATE, closing ( <i>Electric 2.23hp</i> )	1
16	513269900		PLATE, closing ( <i>Electric 1hp</i> )	1
<b>150T &amp; 175T</b>				
16	513270200		PLATE, closing ( <i>Petter AC1ZS</i> )	1
16	513270300		PLATE, closing ( <i>Lister LT1</i> )	1
16	513270400		PLATE, closing ( <i>Electric 2.23hp</i> )	1
16	513270200		PLATE, closing ( <i>Electric 1hp &amp; 1.5hp</i> )	1
17	10S04		WASHER, flat	10
18	353830650		PIN, spirol	1
19	132412010		CIRCLIP	4
20	44S05K		PIN, split	4
21	10S20		WASHER, flat	4

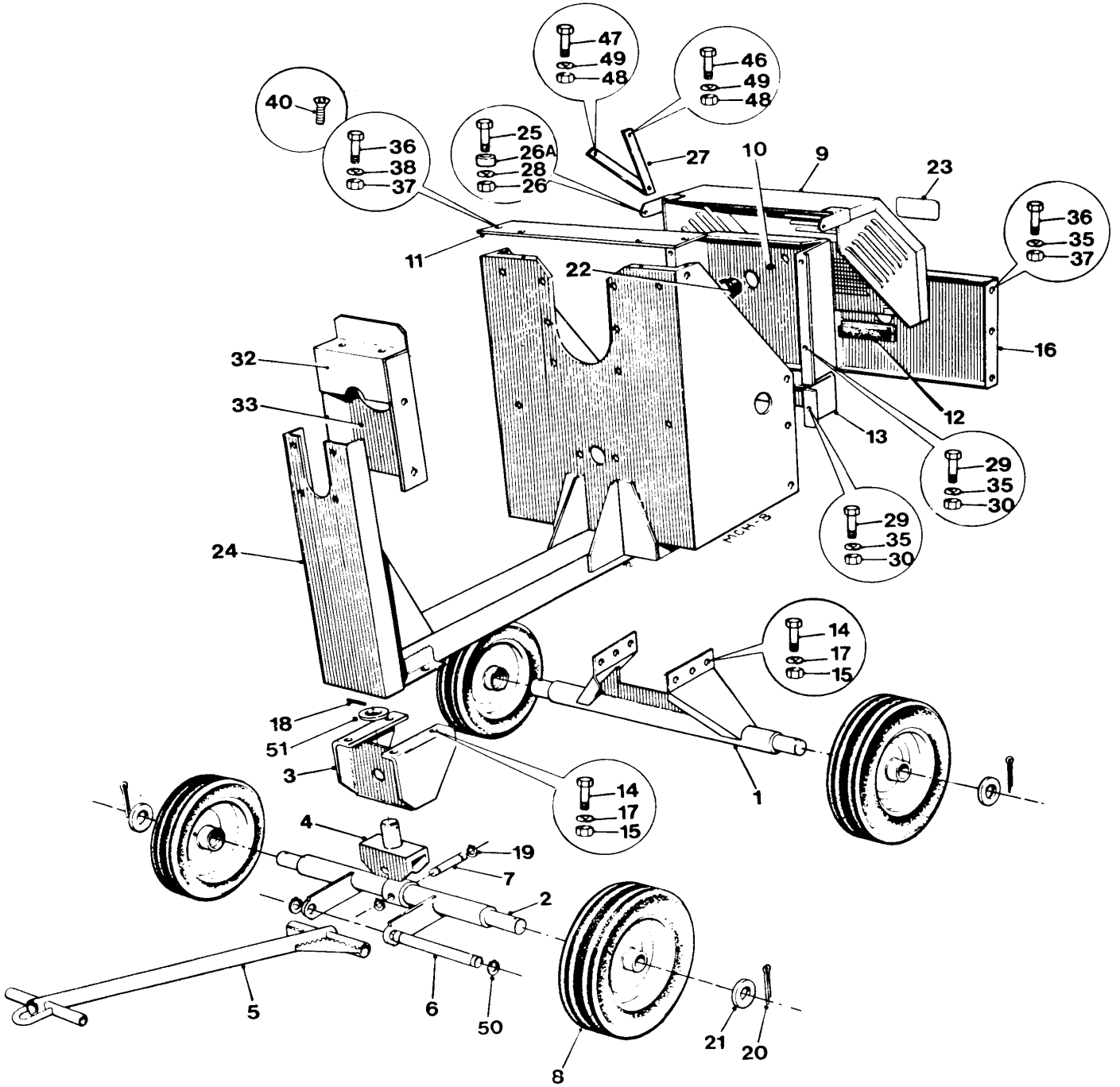

# FOUR WHEEL MAINFRAME & GUARDS

A - 1

Item	Part no	Serial no	Description	Qty
22	241859000		PLUG, polythene	1
23	504600900		DECAL (see page D - 1)	1
24	513268400		MAINFRAME, <b>100T</b>	1
24	513269400		MAINFRAME, <b>150T &amp; 175T</b>	1
25	11S04C		SCREW, set	2
26	7S01		NUT	2
26A	513340800		SPACER	1
<b>100T</b>				
27	513280600	/ 999 \$	STAY, housing lid	1
27	513287200	\$ 1000 / Feb-88	STAY, housing lid	1
<b>150T &amp; 175T</b>				
27	513280600	/ 499 \$	STAY, housing lid	1
27	513287200	\$ 500 / Feb-88	STAY, housing lid	1
28	17S05		WASHER, spring	2
29	66S03CC		SCREW, set	6
30	104S03		NUT	10
	513198400		GUARD, tilt wheel, assembly	1
32	513198402		GUARD, upper	1
33	513198401		GUARD, lower	1
34	332719000		NUT, captive	2
-	513285000		BRACKET, starting handle (not illustrated)	1
35	41S05		WASHER, spring	12
36	66S02BB		SCREW, set	12
37	104S02		NUT	12
38	41S04		WASHER, spring	12
40	206S03C		SCREW, c'sunk socket head	2
41	104S01		NUT	4
42	7S02		NUT	2
43	41S03		WASHER, spring	6
44	200S03G		SCREW	2
45	66S03CC		SCREW, set	4
46	6S02Z		BOLT	1
47	6S02C		BOLT	1
48	87S02		NUT, binx	2
49	10S02		WASHER, flat	2
50	132412010		CIRCLIP	2
51	10S09		WASHER, flat	1

\$ Machine serial numbers

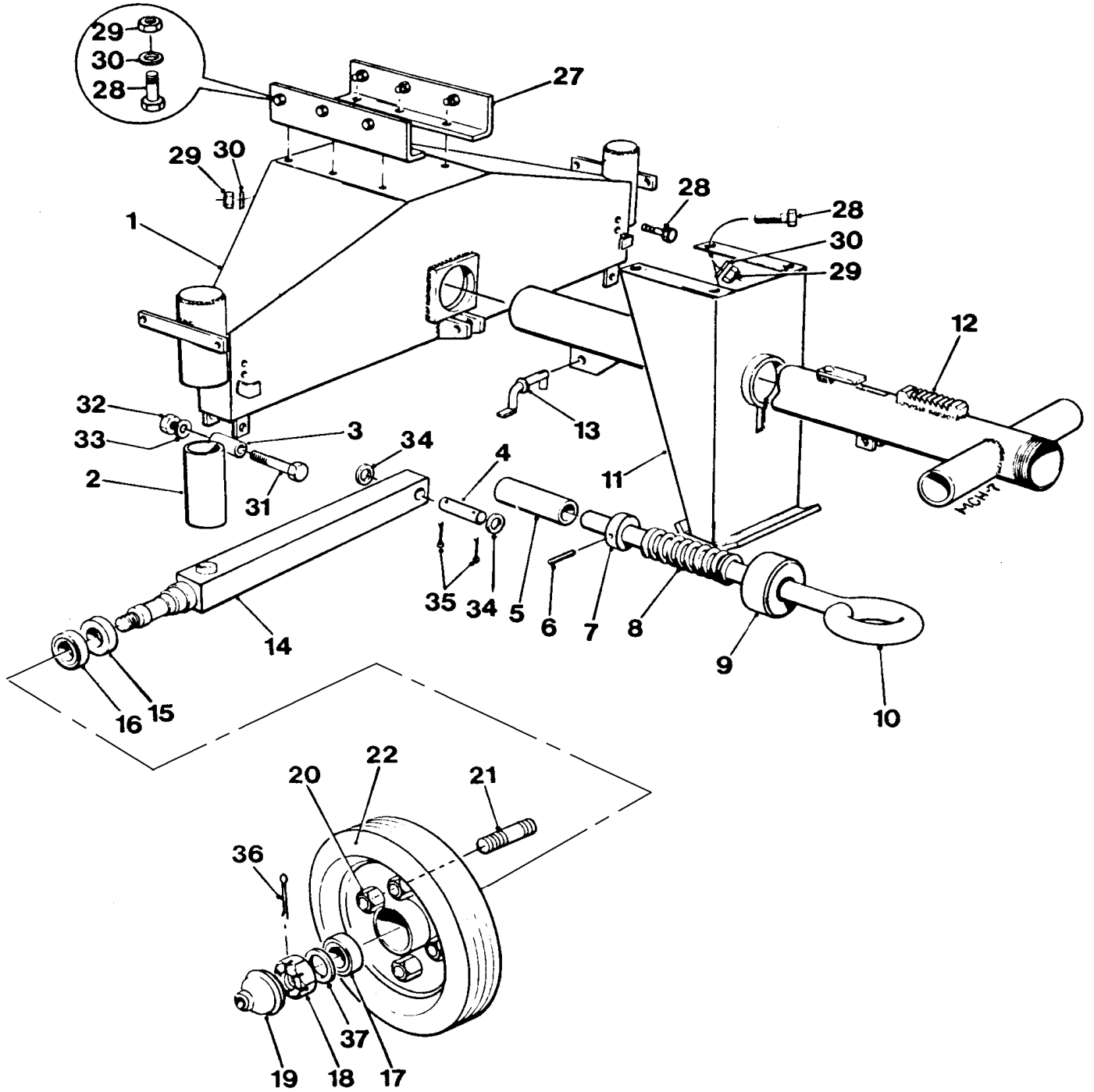

**TWO WHEEL MAINFRAME, slow tow**

**A - 2**

Item	Part no	Serial no	Description	Qty
1	513276400	/ Feb 88	AXLE	1
2	513169500		SPACER, axle	2
3	513168900		SPACER, stub axle retaining	2
4	513168500		PIN, pivot	2
5	513169600		SPACER, towbar	1
6	352410120		PIN, mills	1
7	501386200		COLLAR, towing rod	1
8	501362300		SPRING, compression	1
9	513169200		CAP, end	1
10	513169400		ROD, towing	1
11	513167700		LEG, support	1
12	513167400		TOWBAR	1
13	513167600		PIN, drop nose	1
14	513236500		STUB AXLE	2
15	475117019		SEAL, oil	2
16	475117006		BEARING, roller taper	2
17	30097A0140		BEARING, roller taper	2
18	475117024		NUT, slotted	2
19	475117004		HUB CAP	2
20	475117002		NUT, wheel	8
21	475117003		STUD, wheel	8
22	475117021		WHEEL, assembly	2
-	-		RIM, wheel (order assembly)	2
-	475118002		HUB	2
-	475117007		TYRE	2
-	475117008		TUBE	2
27	513275900		SUPPORT, axle	1
28	69S05E		SCREW, set	16
29	192S05		NUT, binx	16
30	10S04		WASHER, flat	16
31	69S03M		SCREW, set	2
32	104S03		NUT	2
33	41S05		WASHER, spring	2
34	10S06		WASHER, flat	4
35	44S03G		PIN, split	4
36	44S03C		PIN, split	2
37	10S05		WASHER, flat	2

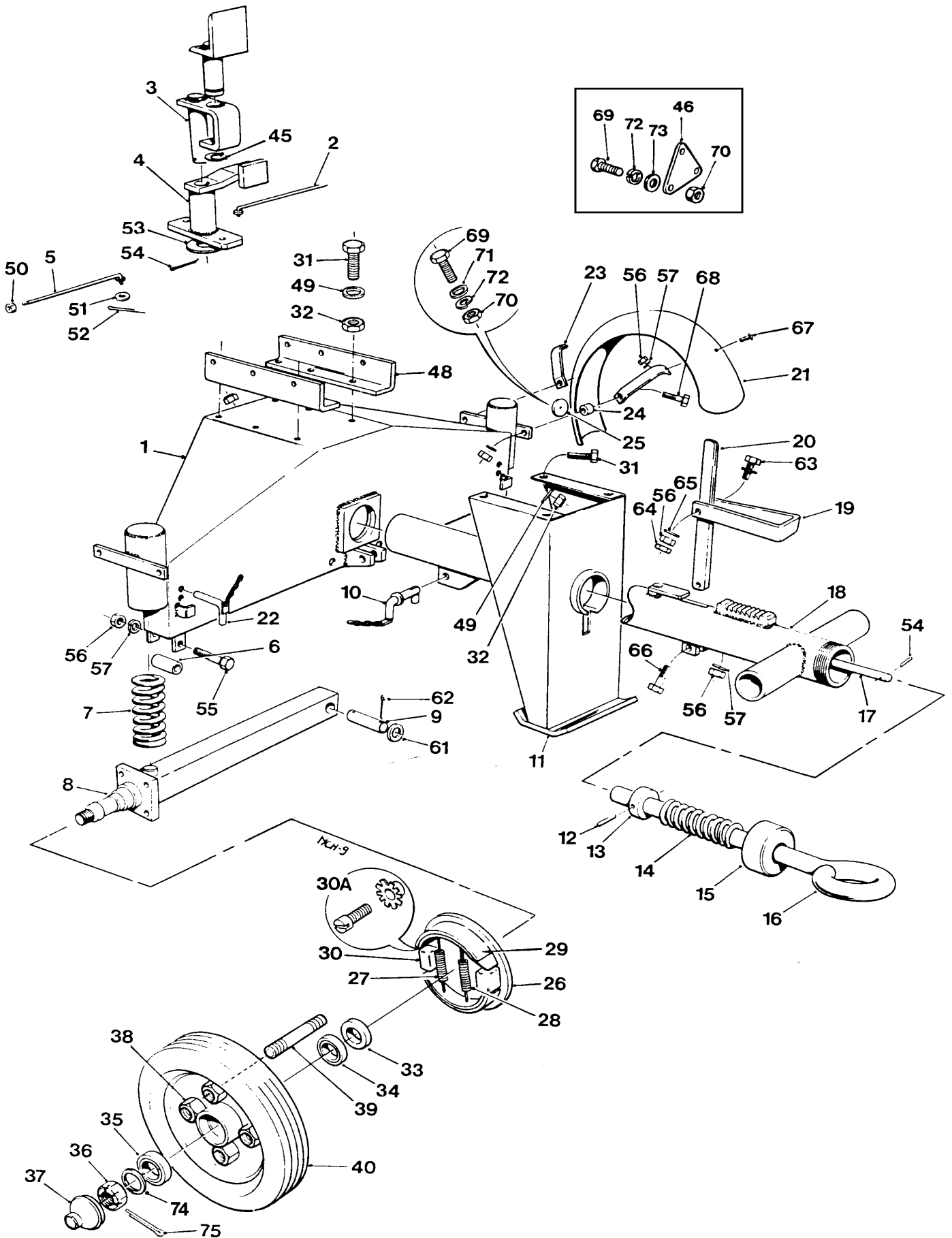

**TWO WHEEL MAINFRAME, fast tow**

Item	Part no	Serial no	Description	Qty
1	513276400	/ Feb 88	AXLE	1
2	513209900		ROD, brake, nearside	1
3	513169000		ARM, compensating	1
4	513209800		ARM,, brake operating	1
5	513210000		ROD, brake, offside	1
6	513168900		SPACER, stub axle retaining	2
7	513169100		SPRING, suspension	2
8	513236701		STUB AXLE, L.H. (illustrated)	1
.....	513236702		STUB AXLE, R.H. (not illustrated)	1
9	513168500		PIN, pivot, stub axle	2
10	513167600		PIN, drop end	1
11	513167700		LEG, support	1
12	352410120		PIN, mills	1
13	501386200		COLLAR, towing rod	1
14	501362300		SPRING, compression	1
15	513169200		CAP, end	1
16	513169400		ROD, towing, straight	1
17	513168800		ROD, push	1
18	513167400		TOWBAR	1
19	513168700		RETAINER, handbrake	1
20	513168600		HANDBRAKE	1
21	513167900		MUDGUARD	2
22	513167500		PIN & CHAIN, stabiliser	2
23	513168200		SUPPORT, mudguard	4
24	513237100		SPACER	4
25	386102000		REFLECTOR, round	2
-	475117010		BRAKE ASSEMBLY, R.H. (illustrated)	1
-	475117011		BRAKE ASSEMBLY, L.H. (not illustrated)	1
26	475117012		BACK PLATE, R.H. (illustrated)	1
-	475117013		BACK PLATE (not illustrated)	1
27	475117014		SPRING, pull off	2
28	475117015		SPRING, pull off	2
29	475117016		BRAKE SHOE (set of 2)	set 2
30	475117017		EXPANDER, R.H. (illustrated)	1
-	475117018		EXPANDER, L.H. (not illustrated)	1
30A	V600164		ADJUSTER	1
31	69S05E		BOLT	16
32	192S05		NUT, binx	16
33	475117019		SEAL, oil	2
34	475117006		BEARING, roller taper	2
35	30097A0140		BEARING, roller taper	2



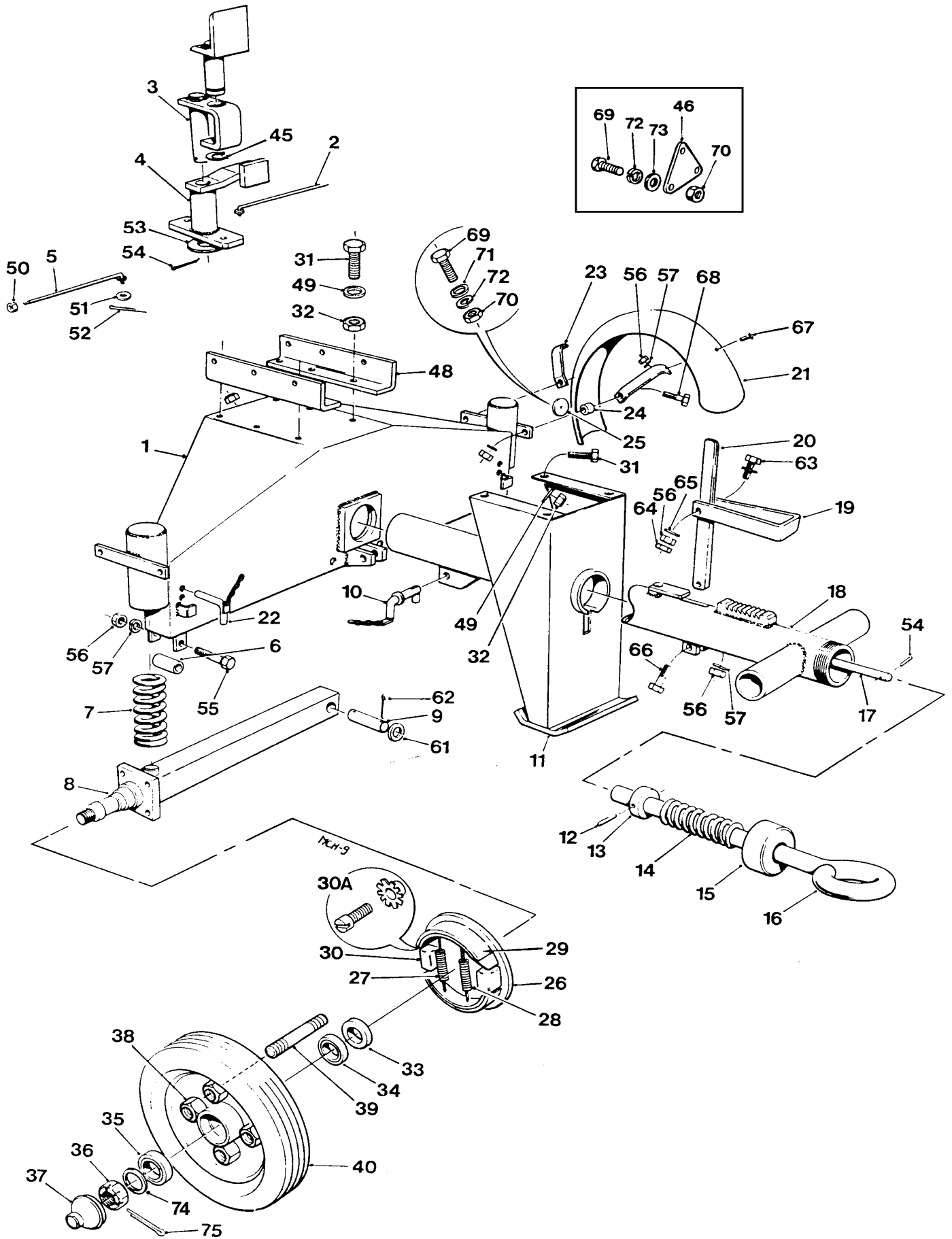

**TWO WHEEL MAINFRAME, fast tow**

**A - 3**

Item	Part no	Serial no	Description	Qty
36	475117020		NUT, slotted	2
37	475117004		HUB CAP	2
38	475117002		NUT, wheel	8
39	475117003		STUD, wheel	8
40	475117000		WHEEL, assembly	2
.....	.....		RIM, wheel ( <i>order assembly</i> )	2
.....	475118001		HUB, wheel	2
.....	475117007		TYRE	2
.....	475117008		TUBE	2
45	142324000		CIRCLIP	1
46	332119000		REFLECTOR, triangular ( <i>fitted as alternative to item 25</i> )	2
48	513275900	/ Feb-88	SUPPORT, axle	2
49	10S04		WASHER, flat	16
50	95S02		NUT, locking	2
51	10S02		WASHER, flat	2
52	44S02B		PIN, split	2
53	10S05		WASHER, flat	1
54	44S03E		PIN, split	2
55	69S03M		BOLT	2
56	104S03		NUT	13
57	41S05		WASHER, spring	11
58	66S02CC		BOLT	8
59	192S02		NUT, binx	8
60	41S04		WASHER, spring	8
61	10S06		WASHER, flat	4
62	44S03G		PIN, split	4
63	69S03H		BOLT	2
64	203S04		NUT, locking	2
65	10S03		WASHER, flat	2
66	66S03C		BOLT	2
67	200S03G		SCREW	4
68	69S03G		BOLT	4
69	284S03E		SCREW	5
70	83S03		NUT	5
71	10S73		WASHER, flat	2
72	41S02		WASHER, spring	5
73	463504000		WASHER, rubber	3
74	10S05		WASHER, flat	2
75	44S03C		PIN, split	2



**DRUM**

**B - 1A**

Item	Part no	Serial no	Description	Qty
10	513152901		BASE, drum, <b>100T</b>	1
10	513161001		BASE, drum, <b>150T &amp; 175</b>	1
11	513151100		BLADE, mixing, <b>100T</b>	2
11	513157500		BLADE, mixing, <b>150T &amp; 175</b>	2
12	513149600		DRUM CENTRE	1
13	88S07D		BEARING	1
14	513152902		CONE, drum, <b>100T</b>	1
14	513161002		CONE, drum, <b>150T</b>	1
14	513203202		CONE, drum, <b>175T</b>	1
16	513208800		NUT, locking	1
17	22096210		WASHER, locking	1
18	513152300		DISTANCE PIECE, drum shaft	1
19	88S20D		BEARING	1
20	132390000		CIRCLIP	1
37	513150100		BEVEL GEAR, drum	1
39	513152200		SHAFT, drum	1
40	513152000		FLANGE, drum shaft	1
41	513152100		WASHER, tab	1
51	66S05D		SCREW	8
51A	28S05G		SCREW	2
58	142330000		CIRCLIP	1
61	513203900		BRIDGE PIECE, <b>100T</b>	1
61	513203800		BRIDGE PIECE, <b>150T &amp; 175T</b>	1
62	513203600		CLIP, drum, <b>100T</b>	1
62	513203100		CLIP, drum, <b>150T &amp; 175T</b>	1
62A	V2000772		SEALANT	tube 1
63	513202800		GASKET	1
64	513199800		WASHER, tab	6
66	10S04		WASHER, flat	AR
69	200S03E		SCREW, blade upper, <b>100T</b>	4
69A	200S03G		SCREW, blade lower, <b>100T</b>	4
69	200S03G		SCREW, <b>150T &amp; 175T</b>	8
70	28S05G		SCREW	2
71	104S03		NUT	8
72	41S05		WASHER, spring	8
76	41S07		WASHER, spring	2
85	10S03		WASHER, flat	13

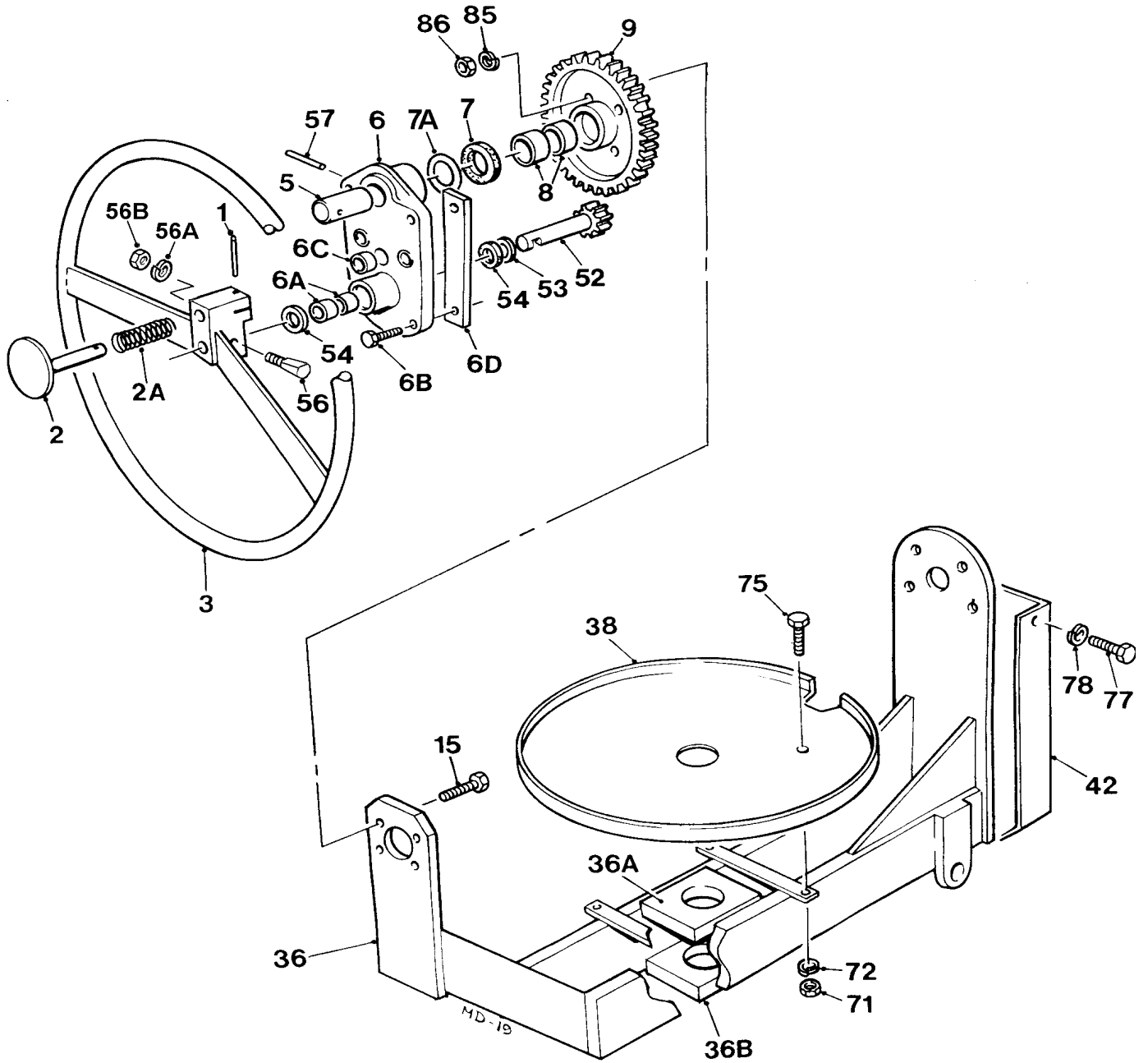

## TRUNNION &amp; TILT WHEEL

B - 1B

Item	Part no	Serial no	Description	Qty
1	54S01A		PIN, spirol	1
2	513194400		PLUNGER, locking	1
2A	513345300		SPRING	1
3	513194500		HANDWHEEL	1
5	513151000		STUB, trunnion journal	1
-	513149400		BRACKET, tilting, assembly	1
6	-		BRACKET, tilting ( <i>order assembly</i> )	1
6A	112821000		BUSH	2
6B	103S04C		SCREW, socket head cap	4
6C	114625320		BUSH	3
6D	513212300		RETAINING BAR, tilting bracket	2
7	225520280		FELT SEAL	1
7A	10S09		WASHER, flat	AR
8	112820000		BUSH	2
9	513149300		GEAR, tilting	1
	145226000		PLUG, core ( <i>not illustrated</i> )	1
15	6S03E		BOLT	4
36	513211400		TRUNNION, <b>100T</b>	1
36	513211500		TRUNNION, <b>150T &amp; 175T</b>	1
36A	513212000		PLATE, upper ( <i>welded</i> )	1
36B	513212000		PLATE, lower ( <i>welded</i> )	1
38	513153000		GUARD, bevel gear	1
42	513152700		GUARD, chain, <b>100T</b>	1
42	513203300		GUARD, chain, <b>150T &amp; 175T</b>	1
52	513151500		PINION, tilting	1
53	10S18		WASHER, flat	1
54	225514220		WASHER, felt	2
56	513151400		PIN, cotter	1
56A	41S05		WASHER, spring	1
56B	2S04		NUT	1
57	55S07Q		PIN, spirol	1
71	104S03		NUT	4
72	41S05		WASHER, spring	4
75	66S03CC		SCREW, set	4
77	66S02CC		SCREW, set	2
78	41S04		WASHER, spring	2
85	10S03		WASHER, flat	4
86	107S14		NUT, 'Nyloc' self-locking	4

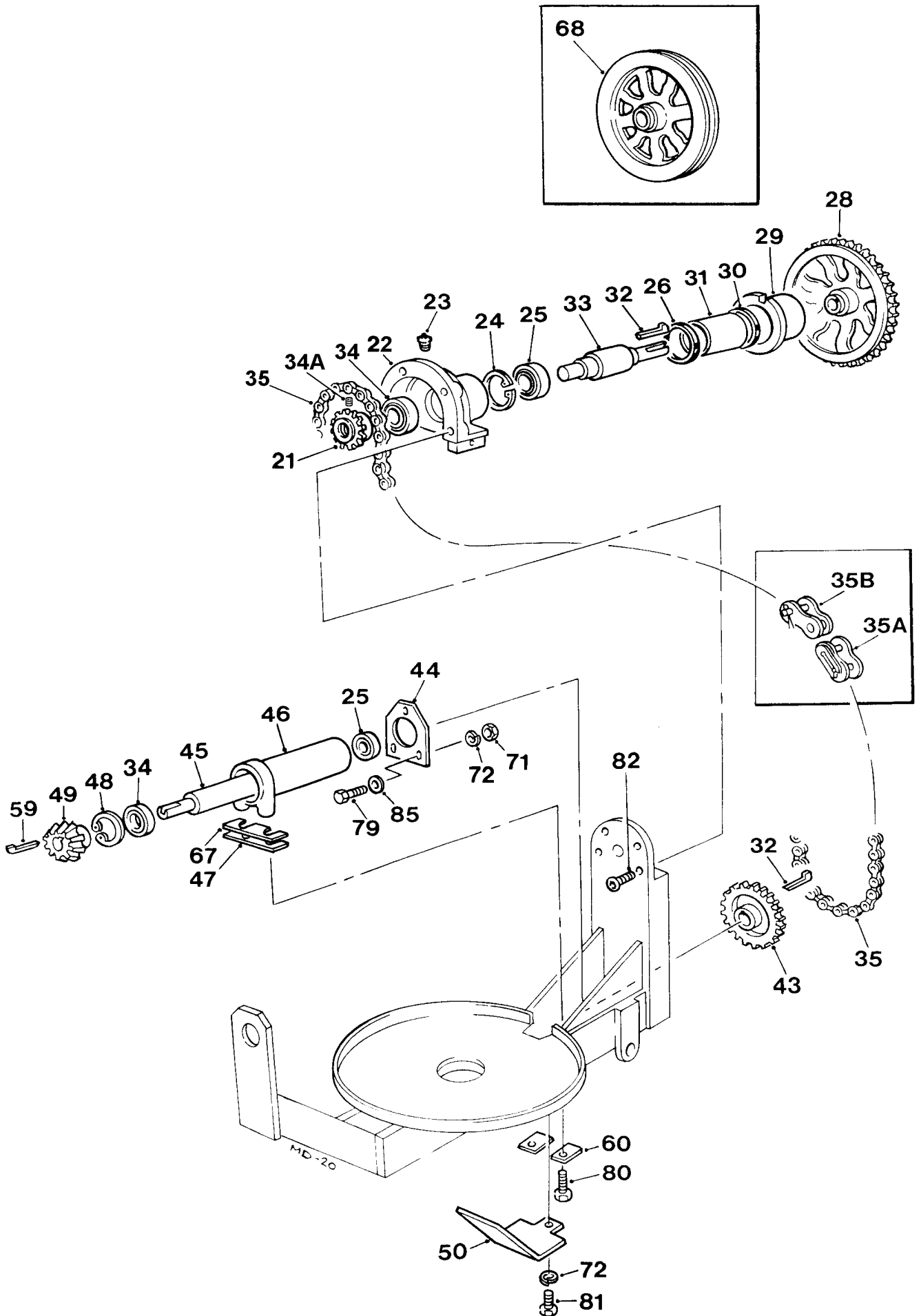

# DRUM DRIVE

# B - 1C

Item	Part no	Serial no	Description	Qty
21	513151600		SPROCKET, countershaft	1
22	513149700		JOURNAL, trunnion	1
23	315803100		PLUG, lubricating	1
24	132352000		CIRCLIP	1
25	88S15D		BEARING	2
26	225104410		FELT STRIP	2
28	513150200		CHAINWHEEL, countershaft	1
29	513150400		BEARING, trunnion	1
30	225104410		FELT STRIP	1
31	513153100		BEARING	1
32	300204140		KEY, gib head	2
33	513151700		COUNTERSHAFT	1
34	88S05D		BEARING	2
34A	57S04D2		SCREW, grub	1
35	134105056		CHAIN, <b>100T</b>	1
35	134105060		CHAIN, <b>150T &amp; 175T</b>	1
35A	134105002		LINK, connecting	1
35B	134105001		LINK, half	AR
43	513150300		SPROCKET, bevel pinion shaft	1
44	513298900		PLATE, adjusting	1
45	513152500		SHAFT, bevel pinion, <b>100T</b>	1
45	513158700		SHAFT, bevel pinion, <b>150T &amp; 175T</b>	1
46	513149800		HOUSING, pinion shaft, <b>100T</b>	1
46	513160700		HOUSING, pinion shaft, <b>150T &amp; 175T</b>	1
47	513152400		PACKING PIECE (set of 4)	sets 2
48	132362000		CIRCLIP	1
49	513278400		BEVEL PINION	1
50	513211800		GUARD, bevel pinion	1
59	300204140		KEY, gib head	1
60	513211900		WASHER, tab	2
67	513211700		PACKER	1
68	513290700		PULLEY, 'V', (electric motors only)	1
71	104S03		NUT	3
72	41S05		WASHER, spring	4
79	66S03C		SCREW	3
80	66S03D		SCREW	2
81	66S03AA		SCREW	1
82	208S03F		SCREW, c/sunk socket	4
85	10S03		WASHER, flat	3



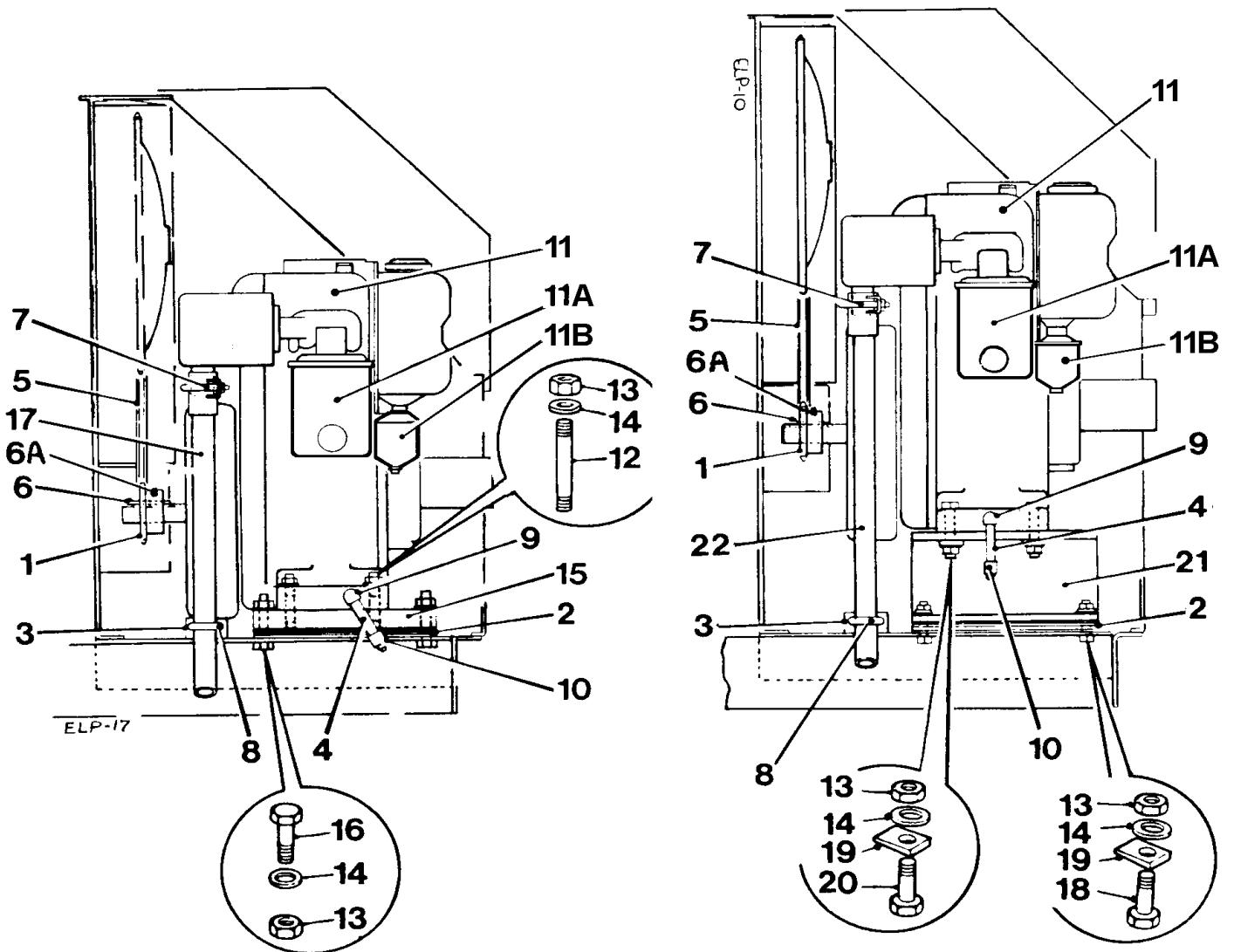
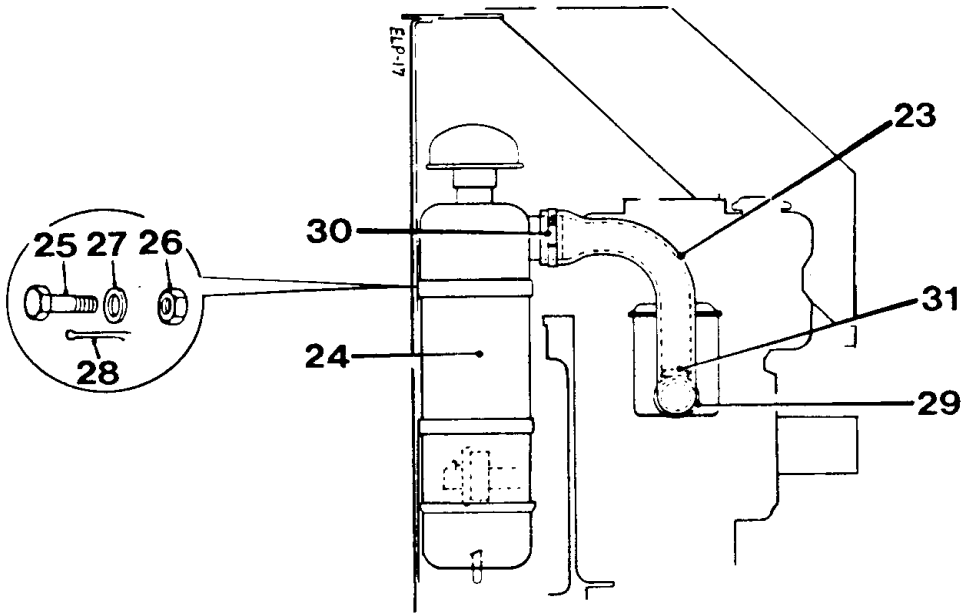

Item	Part no	Serial no	Description	Qty
1	513248300	/ Feb-88	SPROCKET, engine	1
2	513248400		SHIMS	set 1
3	513266800		BRACKET, exhaust	1
4	513256500		PIPE, oil drain	1
5	134105095		CHAIN, roller	1
6	300204160		KEY, gib head	1
6A	57S05D2		SCREW, grub	1
7	354051002		CLAMP & SADDLE	1
8	354051003		CLAMP	1
9	241102000		ELBOW, female	1
10	241902000		SOCKET	1
11	354051000		ENGINE, Lister LT1, assembly	1
11A	EL60131350		FILTER, air	1
11B	EL20113118		FILTER, fuel	1
<b>100T</b>				
12	411411250		STUD	4
13	61S05		NUT, binx	8
14	12S23		WASHER, flat	8
15	513266700		BASE BLOCK, engine	2
16	8S05H		BOLT	4
17	513259100		PIPE, exhaust	1
<b>150T &amp; 175T</b>				
13	61S05		NUT, binx	8
14	12S23		WASHER, flat	8
18	8S05E		BOLT	4
19	105S06		WASHER, taper	8
20	8S05J		BOLT	4
21	513267402		CHANNEL, engine, L.H. (illustrated)	1
-	513267401		CHANNEL, engine, R.H. (not ill.)	1
22	513267500		PIPE, exhaust	1
23	513277900		PIPE, inlet, rubber	1
<b>Machines fitted with Cyclopac air cleaner</b>				
24	220236000		AIR CLEANER	1
25	11S03B		SCREW, set	4
26	61S03		NUT, binx	4
27	12S18		WASHER, flat	4
28	353323025		PIN, split	1
29	394411000		STRIP, rubber	1
30	97S13		CLIP, jubilee	1
31	97S12		CLIP, jubilee	1

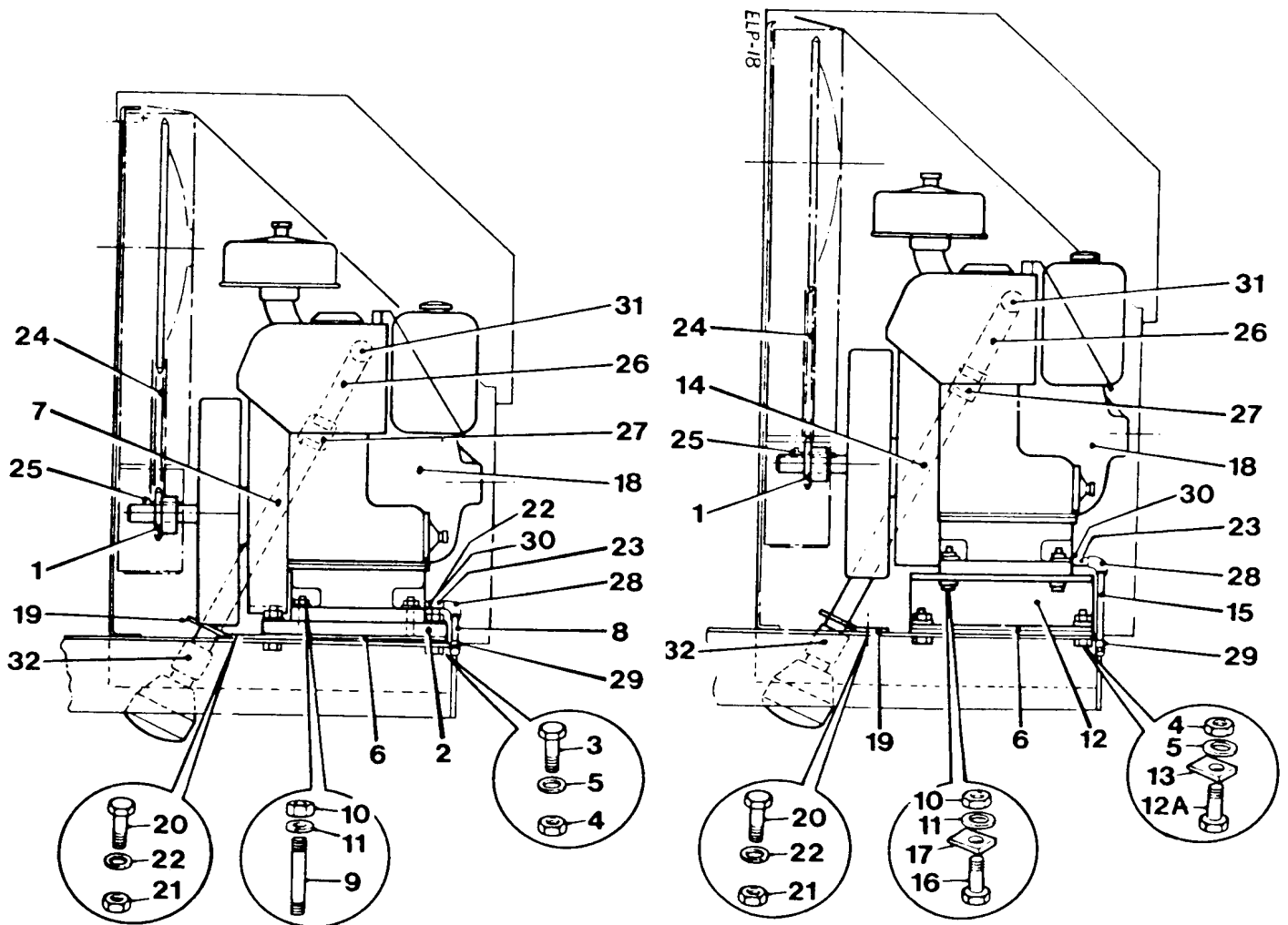
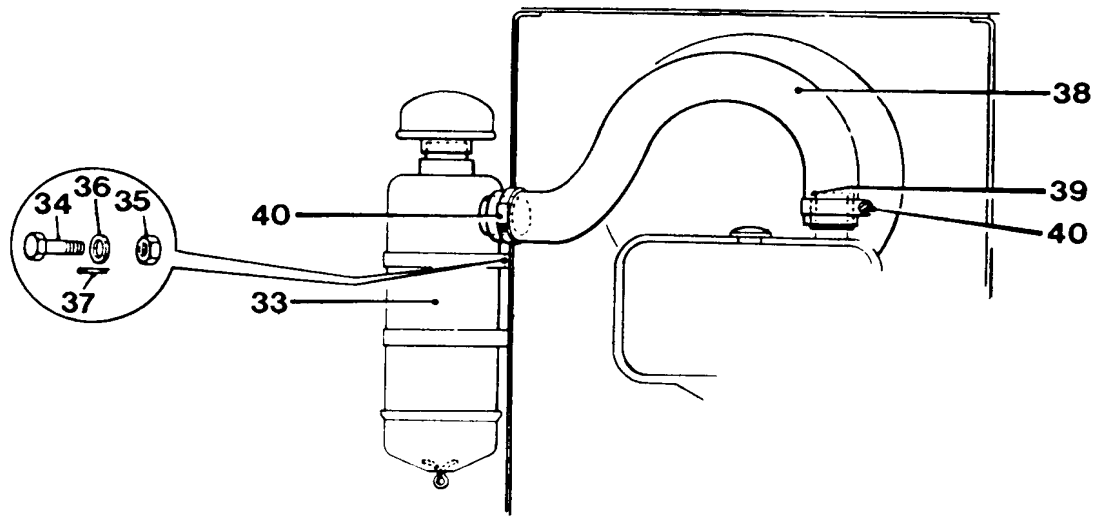

Item	Part no	Serial no	Description	Qty
1	513267300	/ Feb-88	SPROCKET, engine	1
<b>100T</b>				
2	513267000		BLOCK, engine base	2
3	8S05H		BOLT	4
4	61S05		NUT, binx	4
5	12S23		WASHER, flat	4
6	513248400		SHIMS	set 1
7	513267100		PIPE, exhaust	1
8	513278100		PIPE, oil drain	1
9	411411035		ST	4
10	61S04		NUT, binx	4
11	12S20		WASHER, flat	4
<b>150T &amp; 175T</b>				
4	61S05		NUT, binx	4
5	12S23		WASHER, flat	4
10	61S04		NUT, binx	4
11	12S20		WASHER, flat	4
12	513267600		CHANNEL, engine base, R.H.	1
-			CHANNEL, engine base, L.H.	1
12A	8S05F		BOLT	4
13	105S06		WASHER, taper	4
14	513267700		PIPE, exhaust	1
15	513278200		PIPE, oil drain	1
16	8S04E		BOLT	4
17	105S03		WASHER, taper	4
18	354074100		ENGINE, Petter AC1ZS	1
19	513267200		BRACKET, exhaust	1
20	11S05C		SCREW, set	1
21	7S05		NUT	1
22	17S06		WASHER, spring	1
23	513278000		PIPE, oil drain	1
24	134105093		CHAIN, roller	1
25	300204160		KEY, gib head	1
26	240308000		BEND, 90deg, exhaust	1
27	241908000		SOCKET, exhaust	1
28	241102000		ELBOW, female	1
29	241902000		SOCKET	1
30	240100400		NUT, locking	1
31	240708000		ELBOW, m/f, 90deg	1
32	241908000		SOCKET, exhaust, 'T' models only	1
32	241108000		SOCKET, exhaust, 'TFT' & export models	

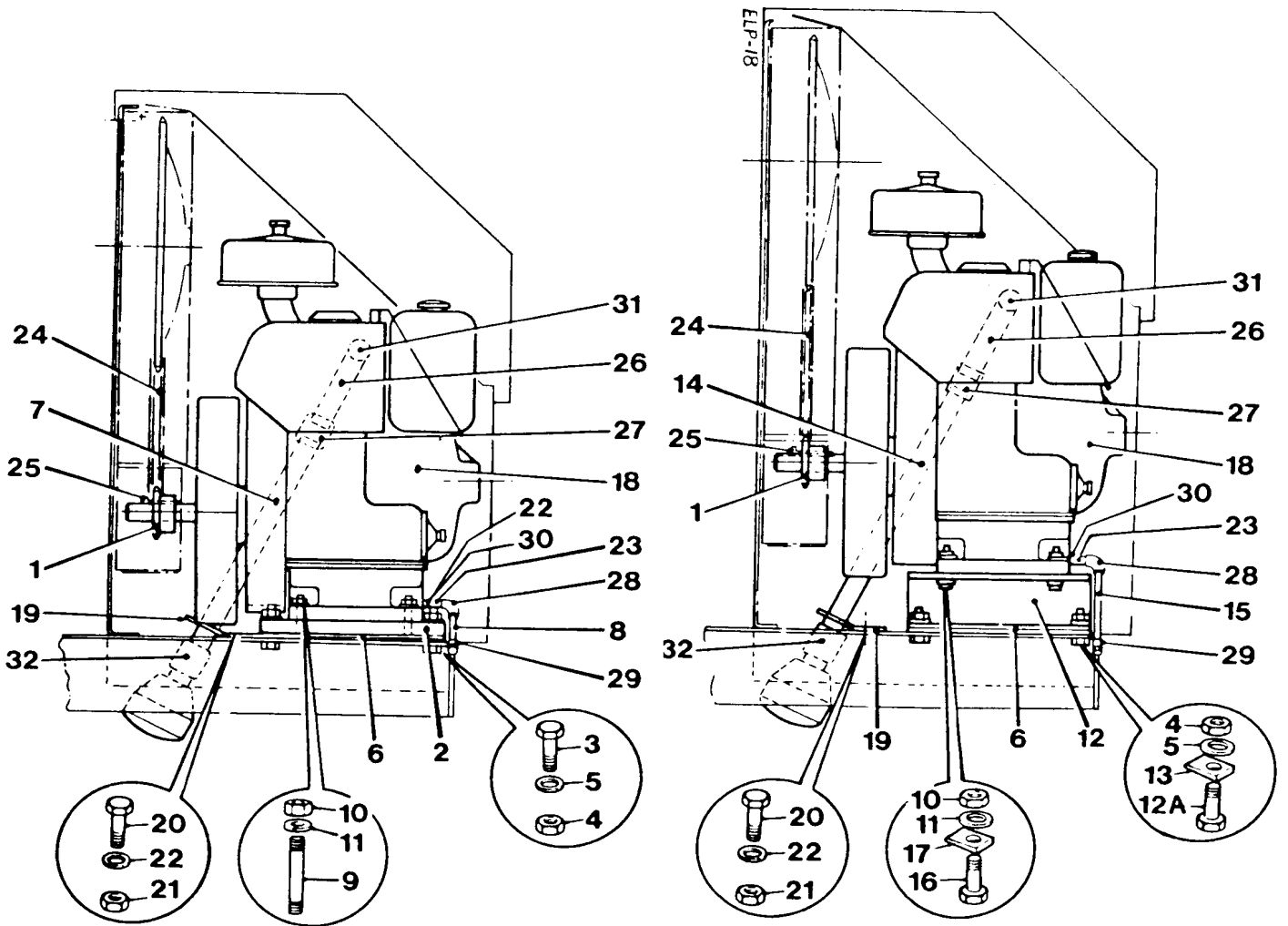
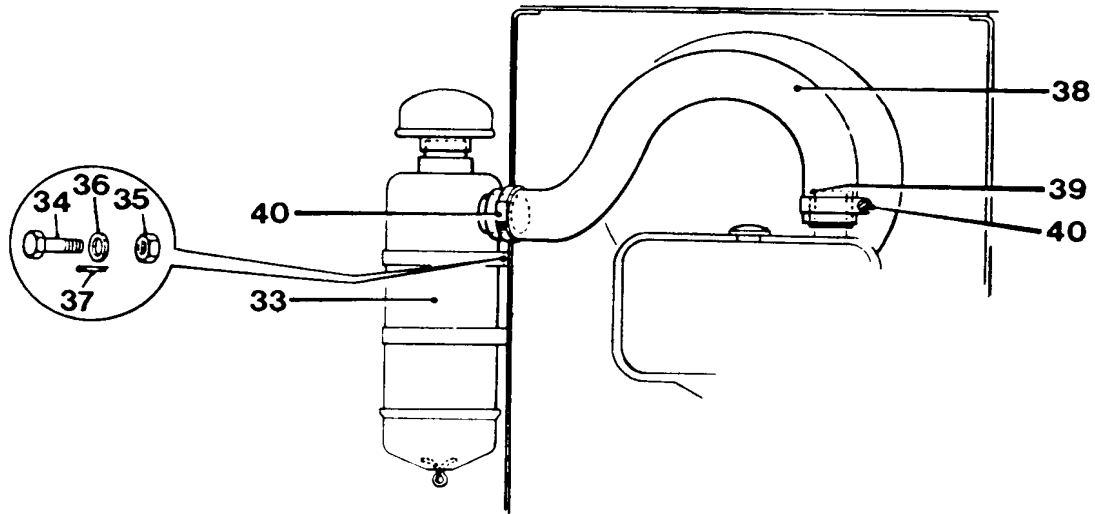

---

Item	Part no	Serial no	Description	Qty
------	---------	-----------	-------------	-----

---

*Continued >>>>*

**Machines fitted with Cyclopac air cleaner**

33	220236000		AIR CLEANER	1
34	11S03B		SCREW, set	4
35	61S03		NUT, binx	4
36	12S18		WASHER, flat	4
37	353323025		PIN, split	1
38	260817001		HOSE, flexible	1
39	260512012		HOSE, rubber	1
40	97S13		CLIP, jubilee	1

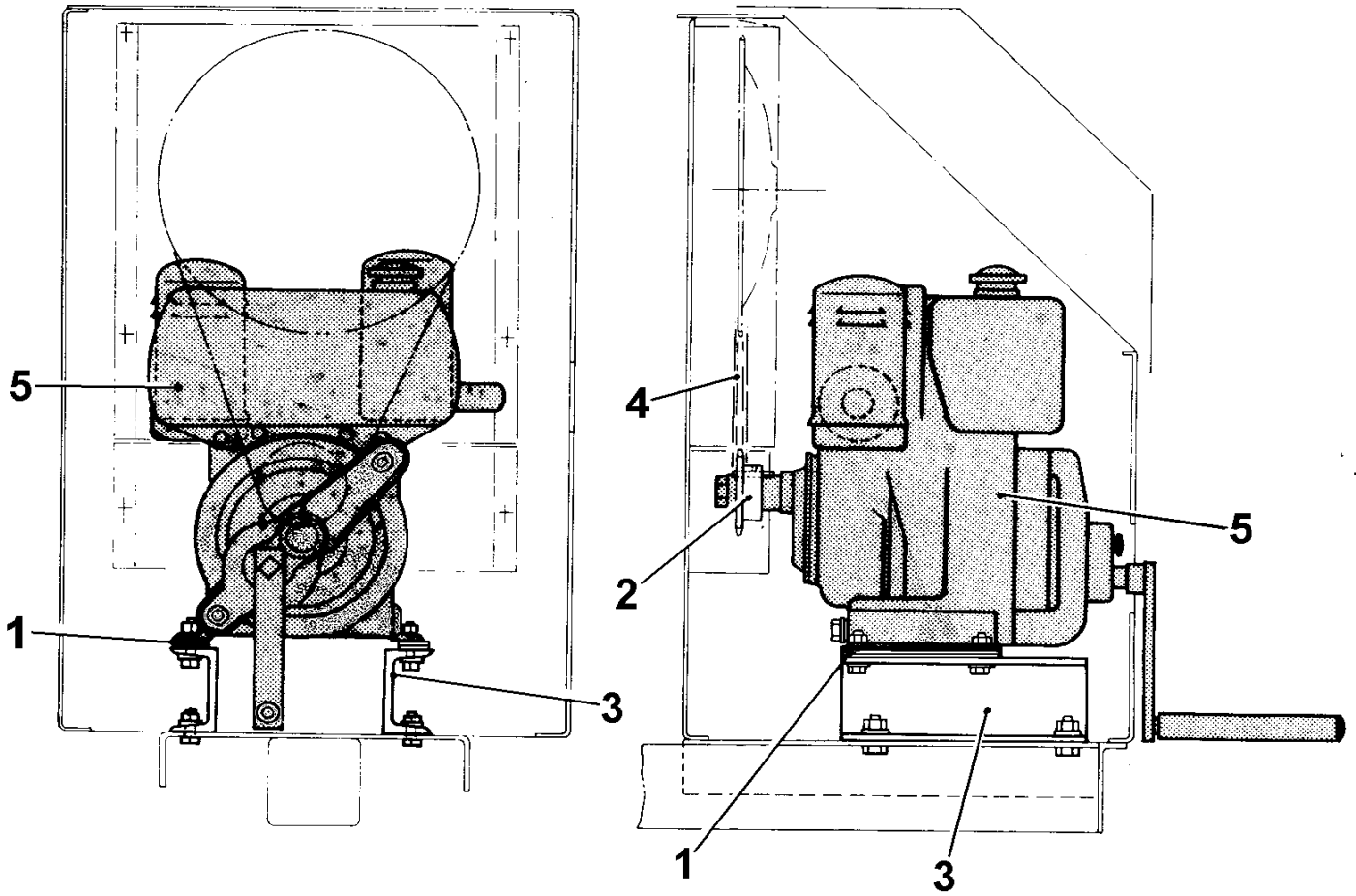

# DRIVE ASSEMBLY, HATZ

# C - 2A

Item	Part no	Serial no	Description	Qty
1	513214400		SHIM	set 1
2	513214500		SPROCKET <i>with</i>	1
.....	188S04C2		SCREW, cone point socket	1
3	513283600		CHANNEL, engine supports <i>with</i>	set 1
.....	66S05D		SCREW, set	4
.....	192S05		NUT, Binx	4
.....	105S06		WASHER, tapered	4
4	134105094		CHAIN, roller	1
5	354072950		ENGINE, "Hatz" air cooled <i>with</i>	1
.....	6S03E		SCREW, set	4
.....	87S03		NUT, Binx	4
.....	105S04		WASHER, tapered	4



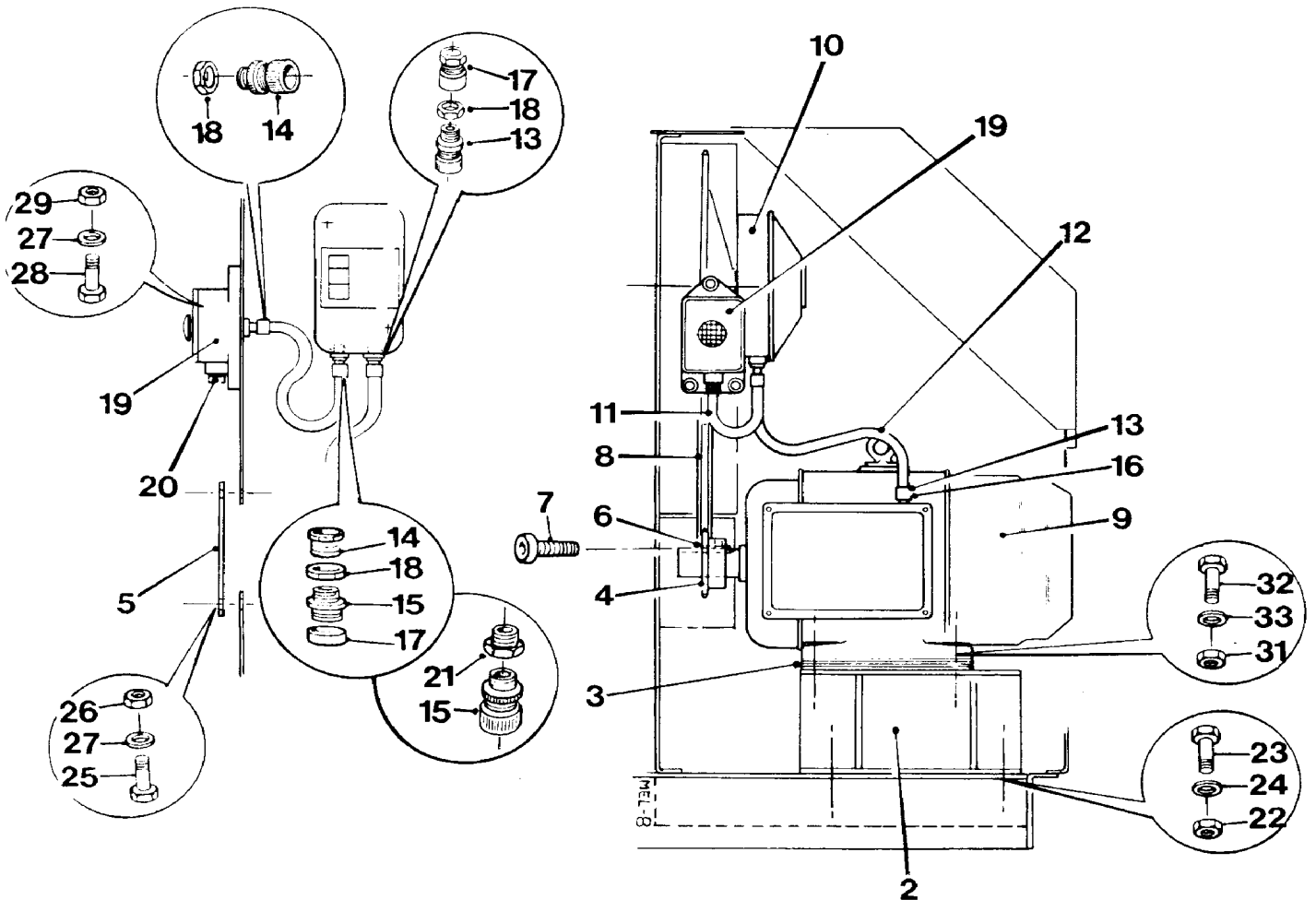
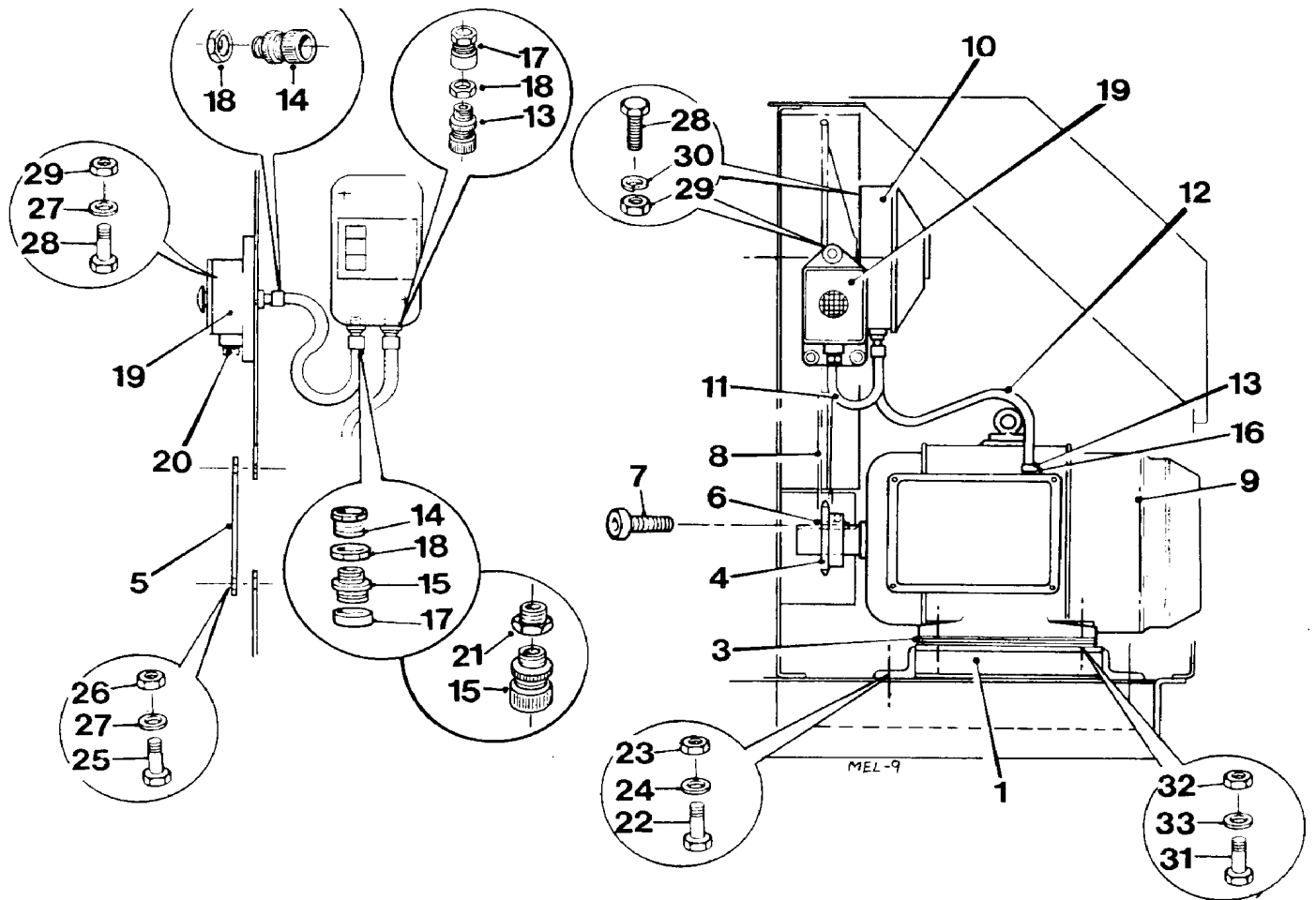

Item	Part no	Date	Description	Qty
<b>100T</b>				
1	513267800	/ Feb-88	BASE, motor	1
<b>150T &amp; 175T</b>				
2	513268001		CHANNEL, motor base, L.H. (illustrated)	1
-	513268002		CHANNEL, motor base, R.H. (not ill.)	1
3	513267900		SHIM, motor base	set 1
4	513198900		SPROCKET, motor	1
5	513271200		COVER, housing back plate	1
6	304710032		KEY, parallel	1
7	188S04D2		SCREW, socket head	1
8	134105095		CHAIN	1
9	202492300		MOTOR, electric, 110/115v	1
9	202485000		MOTOR, electric, 220/240v	1
10	208301300		STARTER, Crabtree, 110/115v	1
10	208303800		STARTER, Allen West, 220/240v	1
11	131730776		CONDUIT	1
12	131731000		CONDUIT	1
13	131271000		COUPLING, 20mm	2
14	131270000		COUPLING, 16mm	2
15	131570016		SOCKET, reducing	1
16	131575020		SOCKET	1
17	131470000		BUSH, brass	2
18	56S13		NUT, locking	4
19	208870000	/ Oct-04	SWITCH, stop, <b>OBSOLETE</b>	1
.....	V602651	/ Oct-04	KEY	
19	208880000	Oct-04 /	SWITCH, stop	1
.....	V603623	Oct-04 /	KEY	
20	133470000		PLUG, stopping	1
21	30097A0213		RING, shifter	1
22	8S05C		BOLT	4
23	61S05		NUT, binx	4
24	12S23		WASHER, flat	4
25	11S02A		SCREW, set	4
26	7S02		NUT	4
27	17S03		WASHER, flat	4
28	11S01B		SCREW, set	5
29	7S01		NUT	5
30	17S02		WASHER, spring	5
31	8S04F		BOLT	4
32	61S04		NUT, binx	4
33	12S20		WASHER, flat	4

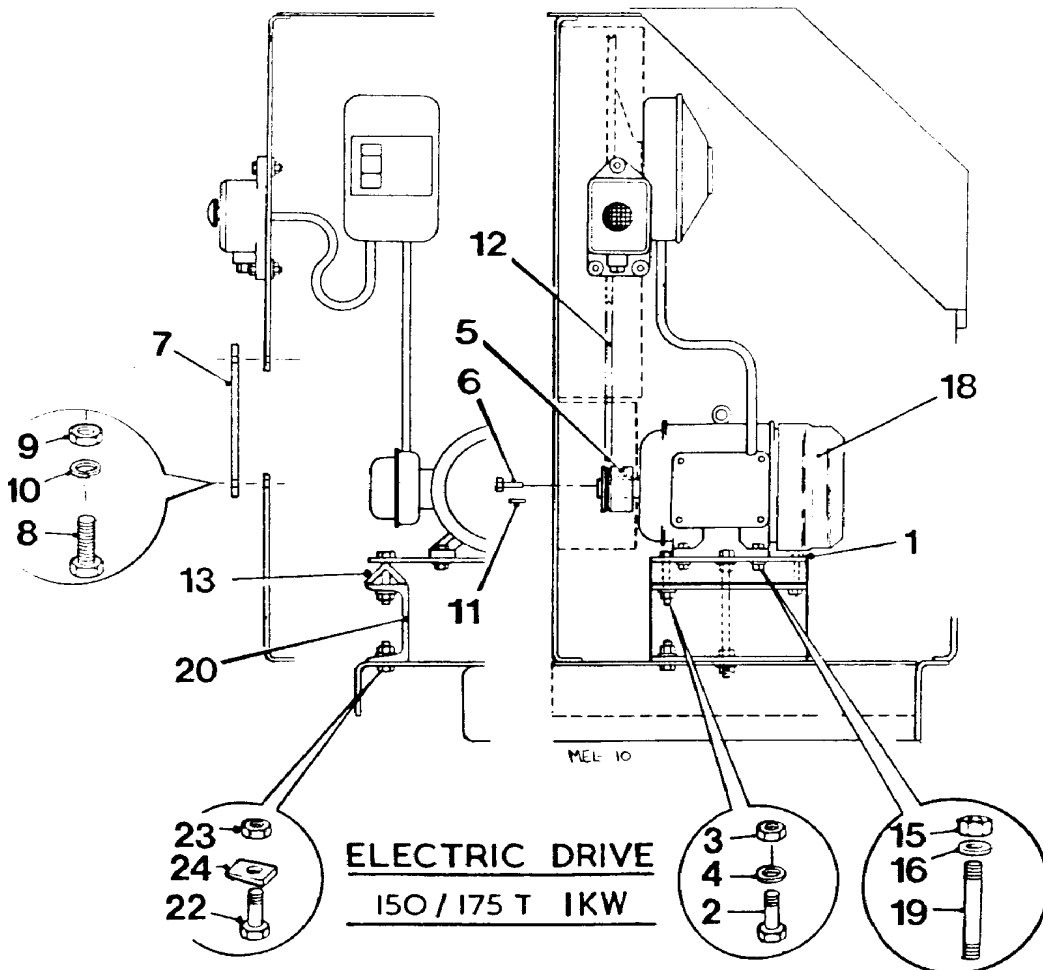
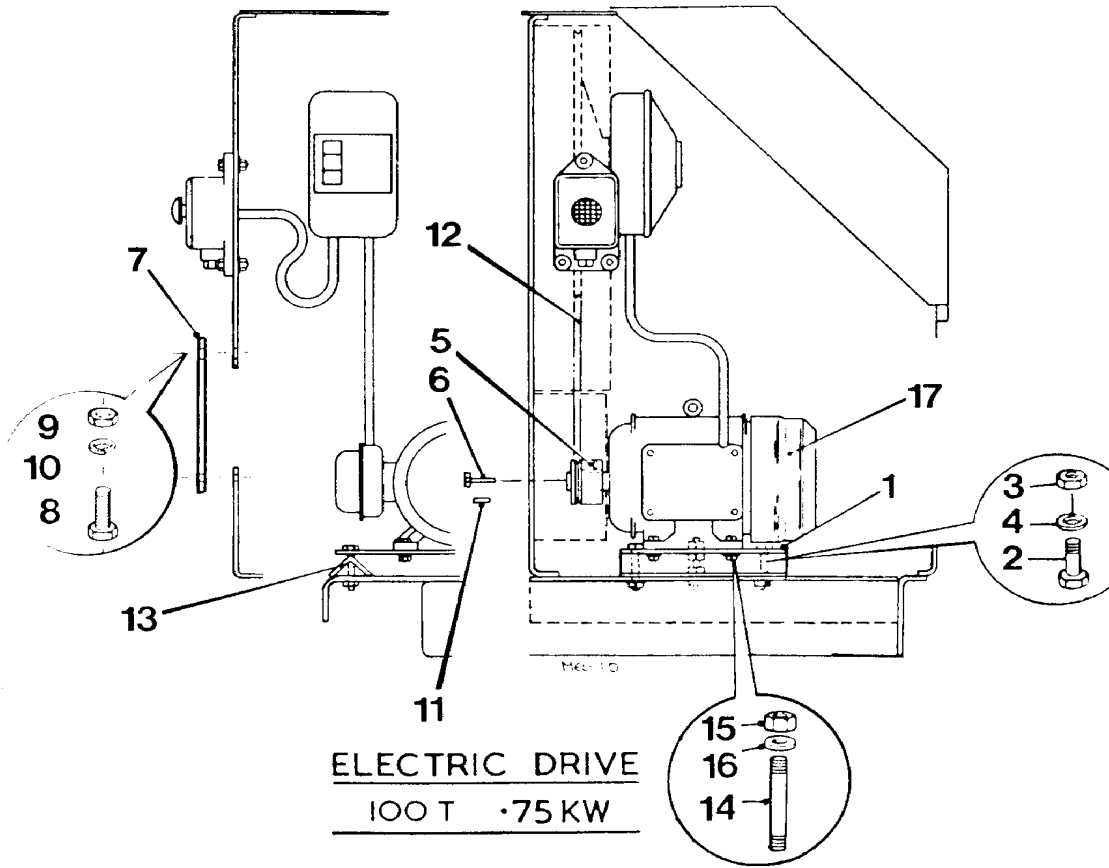

Item	Part no	Serial no	Description	Qty
1	513290400	/ Feb-88	PLATE, motor mounting	1
2	8S05H		BOLT	2
3	61S05		NUT, binx	2
4	12S23		WASHER, flat	2
5	513290600		PULLEY, 'V'	1
6	57S03D2		SCREW, socket head	1
7	513271200		PLATE, cover	1
8	11S02A		SCREW, set	4
9	7S02		NUT	4
10	17S03		WASHER, spring	4
11	304710040		KEY, parallel	1
12	397400100		BELT, 'V'	1

**100T**

13	513290300		ANGLE, motor adjusting	1
14	411411275		STUD	1
15	7S05		NUT	4
16	17S06		WASHER, spring	4
17	202493500		MOTOR, electric, 240v, .75kw (1hp)	1
17	202493600		MOTOR, electric, 110v, 1.1kw (1.5hp)	1

**150T & 175T**

13	513290300		ANGLE, motor adjusting	1
15	7S05		NUT	4
16	17S06		WASHER, spring	4
18	202493700		MOTOR, electric, 240v, 1.1kw (1.5hp)	1
18	202493800		MOTOR, electric, 110v, 1.1kw (1.5hp)	1
19	411411200		STUD	1
20	513290500		SPACER, motor mounting	1
21	513290300		ANGLE, adjusting	1
22	8S05D		BOLT	2
23	7S05		NUT	2
24	105S05		WASHER, taper	2

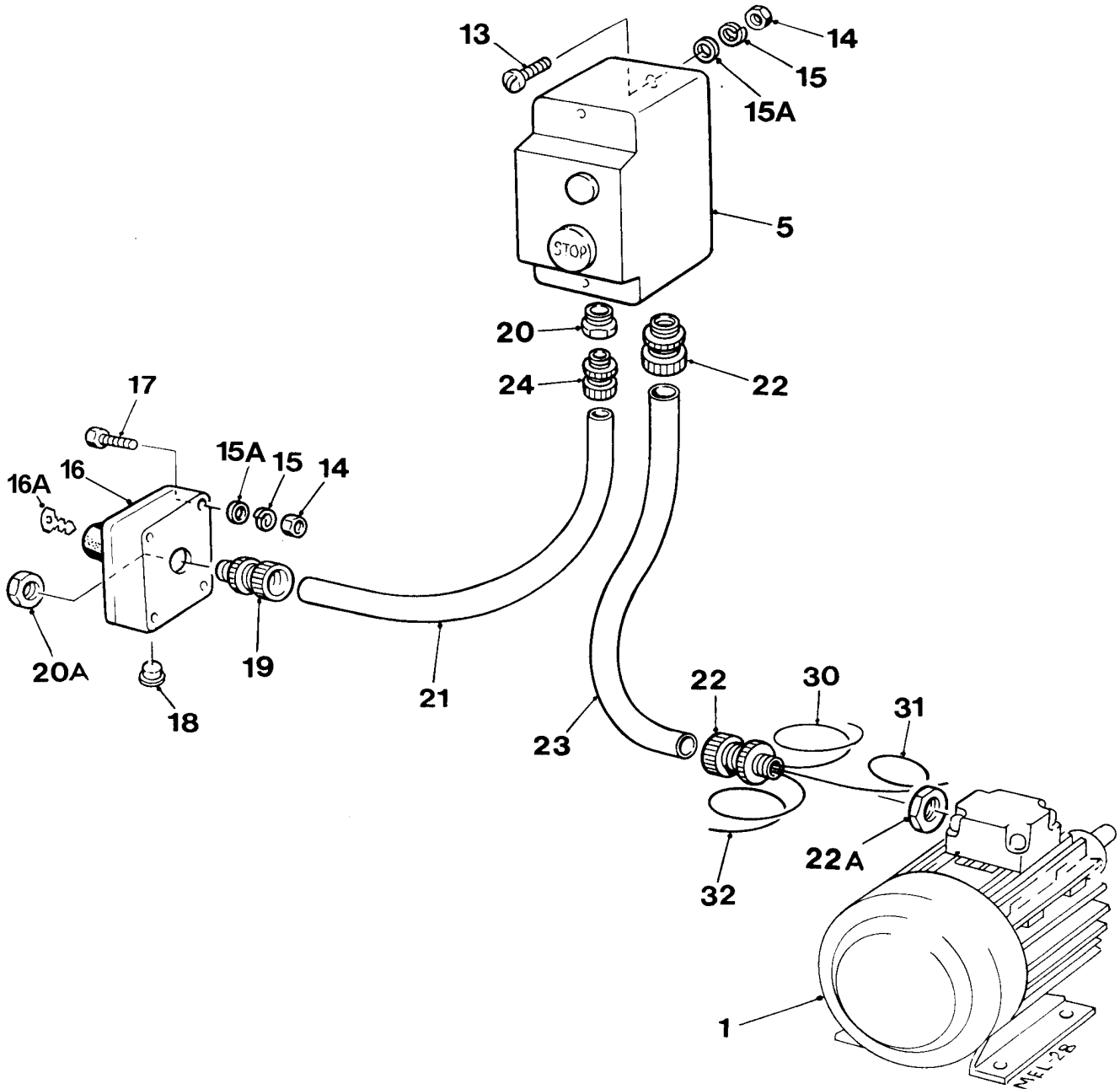

**DANFOSS' START SWITCHES, electric belt drive**

**C - 5**

Item	Part no	Serial no	Description	Qty
1	-		ELECTRIC MOTOR <i>(see Index page)</i>	1
5	208398600		STARTER, 240v, <b>100T, 150T &amp; 175T</b>	1
	- 208398500		CASE, starter	1
	- 192928000		CONTACTOR	1
	- 207818001		RELAY, overload	1
5	208398800		STARTER, 110v, <b>100T</b>	1
	- 208398500		CASE, starter	1
	- 192928000		CONTACTOR	1
	- 207818003		RELAY, overload	1
5	208398900		STARTER, 110v, <b>150T &amp; 175T</b>	1
	- 208398500		CASE, starter	1
	- 192928000		CONTACTOR	1
	- 207818004		RELAY, overload	1
13	16S06C		SCREW, cheese head	2
14	7S01		NUT	4
15	17S02		WASHER, spring	4
15A	267S03		WASHER, flat	4
16	208870000	/ Oct-04	# SWITCH, stop, assembly # <b>OBSOLETE: use 208880000</b>	1
16A	V602651	/ Oct-04	KEY, stop switch	1
16	208880000	Oct-04 /	SWITCH, stop, assembly	1
.....	208880000A	Oct-04 /	MUSHROOM key reset, c/w keys	1
.....	208880000B	Oct-04 /	CONTACTOR	1
.....	208880000C	Oct-04 /	ENCLOSURE	1
16A	V603623	Oct-04 /	KEY, stop switch	2
17	11S01C	/ Oct-04	SCREW, set	2
17	11S01D	Oct-04 /	SCREW, set	
18	133470000		PLUG, stop switch casing	1
19	131270000		COUPLING, 16mm	1
20	131570016		SOCKET, reducing	1
20A	133266050		NUT, backing	1
21	131766010		CONDUIT, 16mm	1
22	131271000		COUPLING, 20mm	2
22A	56S07		NUT, backing	1
23	131770010		CONDUIT, 20mm	1
24	131270000		COUPLING, 16mm	1
<b>110 volts</b>				
30	30788101		WIRE, black	1 metre
31	30788102		WIRE, red	1 metre
32	30788103		WIRE, green/yellow	1 metre
<b>240 volts</b>				
30	144750000		WIRE, black	1 metre
31	144700100		WIRE, red	1 metre
32	144700200		WIRE, green/yellow	1 metre

2

<b>WINGET</b>		WINGET LIMITED P.O. Box 14, Antrim, Lond. Belfm, Lond. BL4 6AW Tel: 01204181511 Fax: 01204181110	
Model	_____		
Serial No.	_____		
Engine No.	_____		
Capacity	Mass (kg)	_____	
SRO No.	Power (kW)	_____	
Year Of Manuf.	Eng. (rpm)	Drum (rpm)	_____

V200337  
A Gredex Group Company

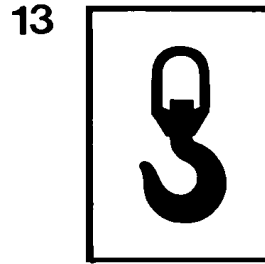

3

**DANGER**

KEEP ENGINE HOUSING  
LID CLOSED WHEN  
ENGINE IS RUNNING



4

**SAFETY WARNING**

- 1 Before starting this machine, the operator should be familiar with the operating instructions issued by the manufacturer.
- 2 The manufacturer's rated capacity must never be exceeded.
- 3 Before carrying out any maintenance, servicing, or greasing, always ensure that the engine has been switched off. Never work on a machine while it is running.

W504694600

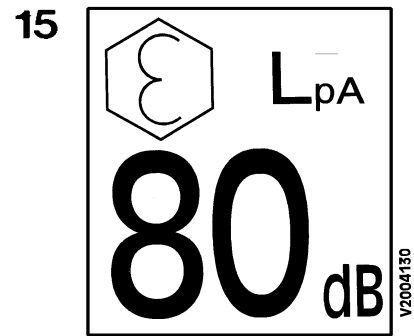

8

**WINGET**

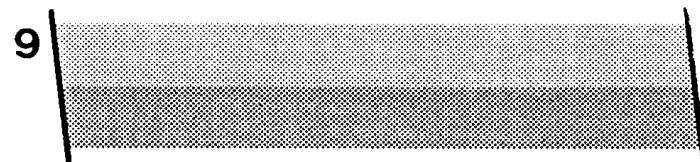
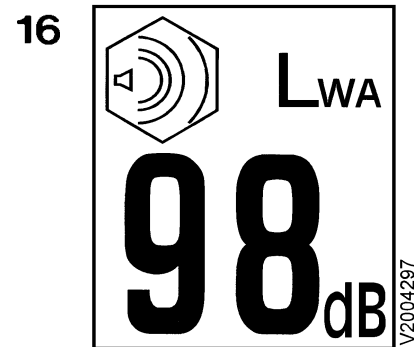

10

**DIESEL FUEL**

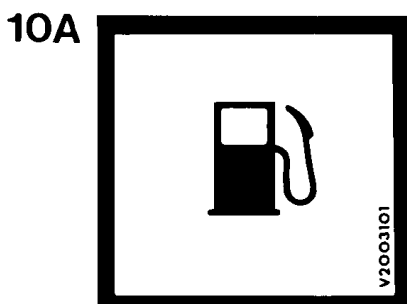

18

**FAILURE TO FOLLOW THE MANUFACTURERS INSTRUCTIONS WHEN STARTING THE ENGINE, MAY CAUSE DAMAGE TO THE MACHINE**

**DECALS & PLATES****D - 1**

<b>Item</b>	<b>Part no</b>	<b>Serial no</b>	<b>Description</b>	<b>Qty</b>
				1
2	V2003037		PLATE, serial	1
—	15S01A		SCREW	4
3	504600900		DECAL, "Engine housing lid closed"	1
4	504694600		DECAL, "Safety Warning"	1
8	V2003039		DECAL, "WINGET" logo,	3
9	V2003038		DECAL, stripe, 2 colour	AR
10	—		DECAL, diesel fuel ( <i>OBSOLETE: use item 10A</i> )	
10A	V2003101		DECAL, "Diesel fuel"	1
13	V2003665		DECAL, "Sling point"	1
14	V2003598		DECAL, "British made"	1
15	V2004130		DECAL, "LPA 80"	1
16	V2004297		DECAL, "LWA 98"	1
17	V2004307		DECAL, "Electrical hazard"	1
18	V2005208		DECAL, "Engine starting procedure"	1



1 **100 T**

2 **150 T**

3 **175 T**

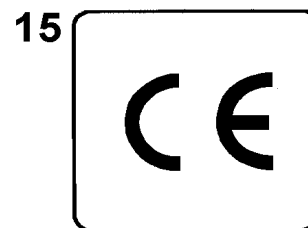
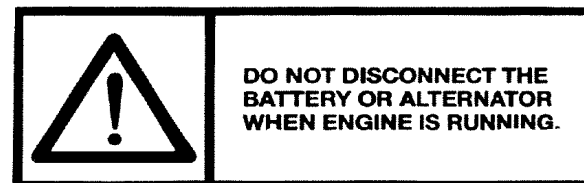
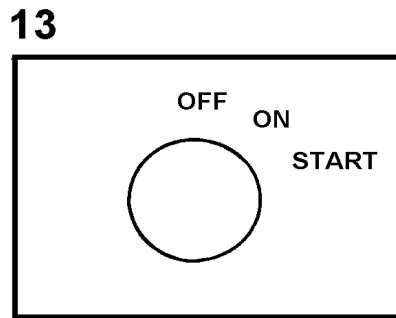
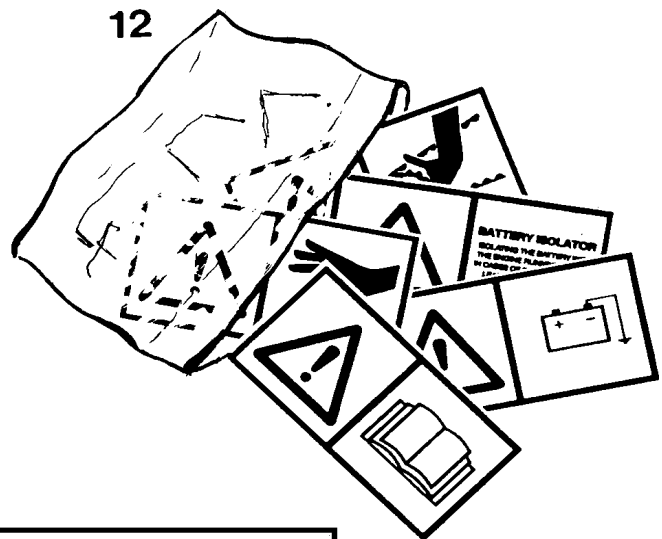
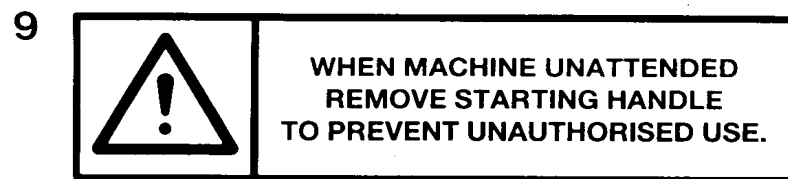
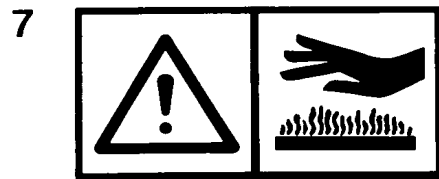
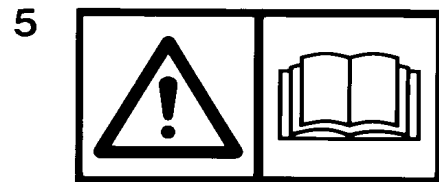
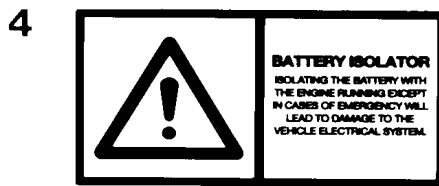
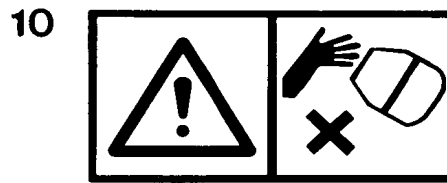

**DECALS & PLATES****D - 2**

<b>Item</b>	<b>Part no</b>	<b>Serial no</b>	<b>Description</b>	<b>Qty</b>
1	V2003105		DECAL, "100T", Black	2
1	V602436		DECAL, "100T" White ( <i>Not illustrated</i> )	-
2	V2003106		DECAL, "150T" Black	2
2	V602437		DECAL, "150T" White ( <i>Not illustrated</i> )	-
3	V2003107		DECAL, "175T" Black	2
3	V602438		DECAL, "175T" White ( <i>Not illustrated</i> )	-
4	V2004227		DECAL, "Battery isolator"	1
5	V2004229		DECAL, "Operators handbook"	1
6	V2004235		DECAL, "Negative earth"	1
7	V2004282		DECAL, "Hot surface"	1
8	V2004281		DECAL, "Chain drive"	1
9	V2004288		DECAL, "Remove start handle"	1
10	V2004289		DECAL, "Keep hands clear of drum"	1
11	V2004302		DECAL, Engine stop"	1
12	V601906		KIT, decals, 100T, 150T, 175T Each kit contains all of the decals required for one machine.	1
13	V2005218		DECAL "Key switch"	1
14	V2004796		DECAL "Do not disconnect battery"	1
15	V2004223		DECAL "CE mark"	1

1

	<p>IN COLD WEATHER, IF THE ENGINE IS HARD TO START, REMOVE THE RUBBER PLUG ON THE ROCKER COVER AND ADD NO MORE THAN 2cc OF ENGINE OIL BEFORE STARTING AS RECOMMENDED IN THE ENGINE OPERATORS HANDBOOK. ALWAYS REFIT THE RUBBER PLUG.</p> <p>V2005276</p>
---	--

2

	<p>LWA</p> <p>101 dB</p> <p>V2005311</p>
---	--

3

	<p>LpA</p> <p>85 dB</p> <p>V2004131</p>
---	---

4

	<p>THE RECOIL STARTER SHOULD ONLY BE USED AS AN "EMERGENCY" MEANS OF STARTING THE ENGINE AND SHOULD BE USED WITH CARE. BE AWARE THAT STARTING THE ENGINE WITH THE RECOIL DUE TO THE ABSENCE OF THE START KEY OR BATTERY OR BECAUSE THE BATTERY IS DISCHARGED WILL RESULT IN DAMAGE TO THE ALTERNATOR.</p> <p>V2005214</p>
---	---



6

	<p><b>IMPORTANT!</b></p> <p>TO AVOID INJURY OR MACHINE DAMAGE DO NOT ENGAGE LOCKING PLUNGER WHILST HANDWHEEL IN MOTION</p>
---	--

**DECALS & PLATES****D - 2A**

<b>Item</b>	<b>Part no</b>	<b>Serial no</b>	<b>Description</b>	<b>Qty</b>
1	V2005276		DECAL, " Engine cold starting"	1
2	V2005311		DECAL, "LWA 101"	1
3	V2004131		DECAL, "LPA 85"	1
4	V2005214		DECAL, "The recoil starter"	1
5	FSE357		DECAL, "ENGINE STOP"	1
6	V2005630		DECAL, "Locking Plunger"	1

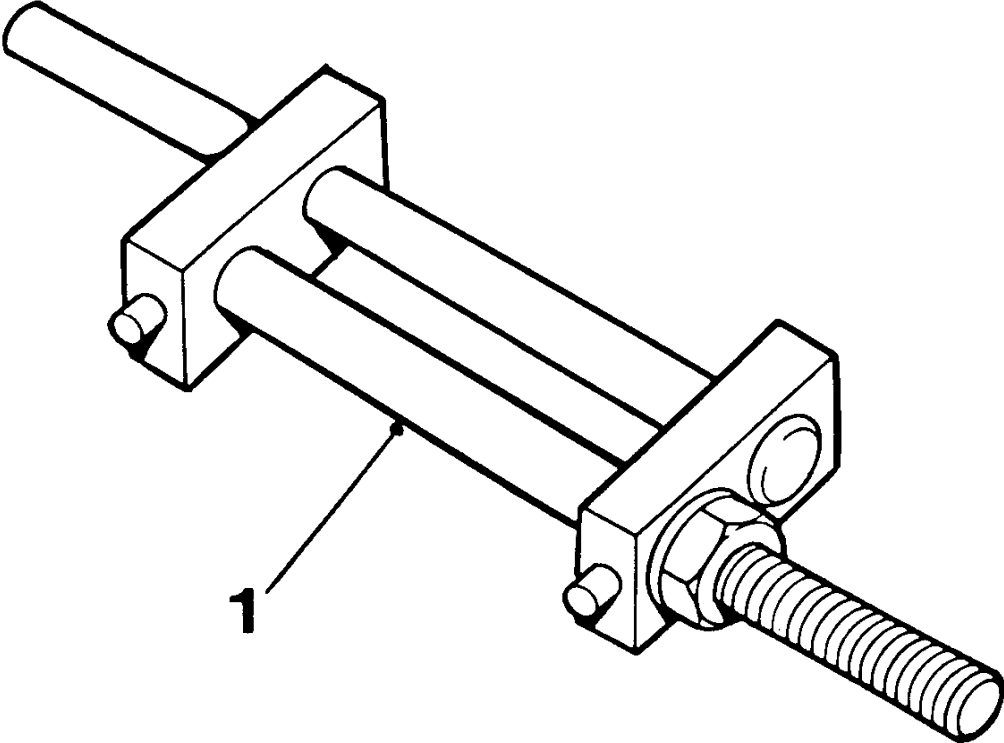

**SPECIAL TOOLS**

---

<b>Item</b>	<b>Part no</b>	<b>Serial no</b>	<b>Description</b>	<b>Qty</b>
1	513204000		CLAMP, drum clip	1

# NUMERICAL INDEX

## Mixers built up to 1988

<b>Part no</b>	<b>Page no</b>	<b>Part no</b>	<b>Page no</b>	<b>Part no</b>	<b>Page no</b>
22096210	<b>B - 1A</b>	134105002	<b>B - 1C</b>	208398500	<b>C - 5</b>
30788101	<b>C - 5</b>	134105056	<b>B - 1C</b>	208398600	<b>C - 5</b>
30788102	<b>C - 5</b>	134105060	<b>B - 1C</b>	208398800	<b>C - 5</b>
30788103	<b>C - 5</b>	134105093	<b>C - 2</b>	208398900	<b>C - 5</b>
112820000	<b>B - 1B</b>	134105094	<b>C - 2A</b>	208870000	<b>C - 3</b>
112821000	<b>B - 1B</b>	134105095	<b>C - 1</b>	208870000	<b>C - 5</b>
114625320	<b>B - 1B</b>	134105095	<b>C - 3</b>	220236000	<b>C - 1</b>
131270000	<b>C - 3</b>	142324000	<b>A - 3</b>	220236000	<b>C - 2</b>
131270000	<b>C - 5</b>	142330000	<b>B - 1A</b>	225104410	<b>B - 1C</b>
131270000	<b>C - 5</b>	144700100	<b>C - 5</b>	225104410	<b>B - 1C</b>
131271000	<b>C - 3</b>	144700200	<b>C - 5</b>	225514220	<b>B - 1B</b>
131271000	<b>C - 5</b>	144750000	<b>C - 5</b>	225520280	<b>B - 1B</b>
131470000	<b>C - 3</b>	145226000	<b>B - 1B</b>	240100400	<b>C - 2</b>
131570016	<b>C - 3</b>	192928000	<b>C - 5</b>	240308000	<b>C - 2</b>
131570016	<b>C - 5</b>	192928000	<b>C - 5</b>	240708000	<b>C - 2</b>
131575020	<b>C - 3</b>	192928000	<b>C - 5</b>	241102000	<b>C - 1</b>
131730776	<b>C - 3</b>	202485000	<b>C - 3</b>	241102000	<b>C - 2</b>
131731000	<b>C - 3</b>	202492300	<b>C - 3</b>	241108000	<b>C - 2</b>
131766010	<b>C - 5</b>	202493500	<b>C - 4</b>	241859000	<b>A - 1</b>
131770010	<b>C - 5</b>	202493600	<b>C - 4</b>	241902000	<b>C - 1</b>
132352000	<b>B - 1C</b>	202493700	<b>C - 4</b>	241902000	<b>C - 2</b>
132362000	<b>B - 1C</b>	202493800	<b>C - 4</b>	241908000	<b>C - 2</b>
132390000	<b>B - 1A</b>	207818001	<b>C - 5</b>	241908000	<b>C - 2</b>
132412010	<b>A - 1</b>	207818003	<b>C - 5</b>	260512012	<b>C - 2</b>
132412010	<b>A - 1</b>	207818004	<b>C - 5</b>	260817001	<b>C - 2</b>
133266050	<b>C - 5</b>	208301300	<b>C - 3</b>	300204140	<b>B - 1C</b>
133470000	<b>C - 3</b>	208303800	<b>C - 3</b>	300204140	<b>B - 1C</b>
133470000	<b>C - 5</b>	208398500	<b>C - 5</b>	300204160	<b>C - 1</b>
134105001	<b>B - 1C</b>	208398500	<b>C - 5</b>	300204160	<b>C - 2</b>

<b>Part no</b>	<b>Page no</b>
304710032	<b>C - 3</b>
304710040	<b>C - 4</b>
315803100	<b>B - 1C</b>
332119000	<b>A - 3</b>
332719000	<b>A - 1</b>
352410120	<b>A - 2</b>
352410120	<b>A - 3</b>
353323025	<b>C - 1</b>
353323025	<b>C - 2</b>
353830650	<b>A - 1</b>
354051000	<b>C - 1</b>
354051002	<b>C - 1</b>
354051003	<b>C - 1</b>
354072950	<b>C - 2A</b>
354074100	<b>C - 2</b>
386102000	<b>A - 3</b>
394411000	<b>C - 1</b>
397400100	<b>C - 4</b>
411411035	<b>C - 2</b>
411411200	<b>C - 4</b>
411411250	<b>C - 1</b>
411411275	<b>C - 4</b>
463504000	<b>A - 3</b>
475106000	<b>A - 1</b>
475117000	<b>A - 3</b>
475117002	<b>A - 2</b>
475117002	<b>A - 3</b>
475117003	<b>A - 2</b>
475117003	<b>A - 3</b>
475117004	<b>A - 2</b>
475117004	<b>A - 3</b>
475117006	<b>A - 2</b>
475117006	<b>A - 3</b>

<b>Part no</b>	<b>Page no</b>
475117007	<b>A - 2</b>
475117007	<b>A - 3</b>
475117008	<b>A - 2</b>
475117008	<b>A - 3</b>
475117010	<b>A - 3</b>
475117011	<b>A - 3</b>
475117012	<b>A - 3</b>
475117013	<b>A - 3</b>
475117014	<b>A - 3</b>
475117015	<b>A - 3</b>
475117016	<b>A - 3</b>
475117017	<b>A - 3</b>
475117018	<b>A - 3</b>
475117019	<b>A - 2</b>
475117019	<b>A - 3</b>
475117020	<b>A - 3</b>
475117021	<b>A - 2</b>
475117024	<b>A - 2</b>
475118001	<b>A - 3</b>
475118002	<b>A - 2</b>
501362300	<b>A - 2</b>
501362300	<b>A - 3</b>
501386200	<b>A - 2</b>
501386200	<b>A - 3</b>
504600900	<b>A - 1</b>
504600900	<b>D - 1</b>
504694600	<b>D - 1</b>
513149300	<b>B - 1B</b>
513149400	<b>B - 1B</b>
513149600	<b>B - 1A</b>
513149700	<b>B - 1C</b>
513149800	<b>B - 1C</b>
513150100	<b>B - 1A</b>

<b>Part no</b>	<b>Page no</b>
513150200	<b>B - 1C</b>
513150300	<b>B - 1C</b>
513150400	<b>B - 1C</b>
513151000	<b>B - 1B</b>
513151100	<b>B - 1A</b>
513151400	<b>B - 1B</b>
513151500	<b>B - 1B</b>
513151600	<b>B - 1C</b>
513151700	<b>B - 1C</b>
513152000	<b>B - 1A</b>
513152100	<b>B - 1A</b>
513152200	<b>B - 1A</b>
513152300	<b>B - 1A</b>
513152400	<b>B - 1C</b>
513152500	<b>B - 1C</b>
513152700	<b>B - 1B</b>
513152901	<b>B - 1A</b>
513152902	<b>B - 1A</b>
513153000	<b>B - 1B</b>
513153100	<b>B - 1C</b>
513154500	<b>A - 1</b>
513154700	<b>A - 1</b>
513154800	<b>A - 1</b>
513155000	<b>A - 1</b>
513157500	<b>B - 1A</b>
513158700	<b>B - 1C</b>
513160700	<b>B - 1C</b>
513161001	<b>B - 1A</b>
513161002	<b>B - 1A</b>
513167400	<b>A - 2</b>
513167400	<b>A - 3</b>
513167500	<b>A - 3</b>
513167600	<b>A - 2</b>



<b>Part no</b>	<b>Page no</b>
513167600	<b>A - 3</b>
513167700	<b>A - 2</b>
513167700	<b>A - 3</b>
513167900	<b>A - 3</b>
513168200	<b>A - 3</b>
513168500	<b>A - 2</b>
513168500	<b>A - 3</b>
513168600	<b>A - 3</b>
513168700	<b>A - 3</b>
513168800	<b>A - 3</b>
513168900	<b>A - 2</b>
513168900	<b>A - 3</b>
513169000	<b>A - 3</b>
513169100	<b>A - 3</b>
513169200	<b>A - 2</b>
513169200	<b>A - 3</b>
513169400	<b>A - 2</b>
513169400	<b>A - 3</b>
513169500	<b>A - 2</b>
513169600	<b>A - 2</b>
513194400	<b>B - 1B</b>
513194500	<b>B - 1B</b>
513197900	<b>A - 1</b>
513198400	<b>A - 1</b>
513198401	<b>A - 1</b>
513198402	<b>A - 1</b>
513198500	<b>A - 1</b>
513198900	<b>C - 3</b>
513199800	<b>B - 1A</b>
513202800	<b>B - 1A</b>
513203100	<b>B - 1A</b>
513203202	<b>B - 1A</b>
513203300	<b>B - 1B</b>

<b>Part no</b>	<b>Page no</b>
513203400	<b>A - 1</b>
513203600	<b>B - 1A</b>
513203800	<b>B - 1A</b>
513203900	<b>B - 1A</b>
513204000	<b>D - 3</b>
513205300	<b>A - 1</b>
513205600	<b>A - 1</b>
513205700	<b>A - 1</b>
513208800	<b>B - 1A</b>
513209800	<b>A - 3</b>
513209900	<b>A - 3</b>
513210000	<b>A - 3</b>
513211400	<b>B - 1B</b>
513211500	<b>B - 1B</b>
513211700	<b>B - 1C</b>
513211800	<b>B - 1C</b>
513211900	<b>B - 1C</b>
513212000	<b>B - 1B</b>
513212300	<b>B - 1B</b>
513214400	<b>C - 1A</b>
513214500	<b>C - 1A</b>
513236500	<b>A - 2</b>
513236701	<b>A - 3</b>
513236702	<b>A - 3</b>
513237100	<b>A - 3</b>
513248300	<b>C - 1</b>
513248400	<b>C - 1</b>
513248400	<b>C - 2</b>
513248700	<b>A - 1</b>
513256500	<b>C - 1</b>
513259100	<b>C - 1</b>
513266700	<b>C - 1</b>
513266800	<b>C - 1</b>

<b>Part no</b>	<b>Page no</b>
513266900	<b>A - 1</b>
513267000	<b>C - 2</b>
513267100	<b>C - 2</b>
513267200	<b>C - 2</b>
513267300	<b>C - 2</b>
513267401	<b>C - 1</b>
513267402	<b>C - 1</b>
513267500	<b>C - 1</b>
513267600	<b>C - 2</b>
513267700	<b>C - 2</b>
513267800	<b>C - 3</b>
513267900	<b>C - 3</b>
513268001	<b>C - 3</b>
513268002	<b>C - 3</b>
513268400	<b>A - 1</b>
513269400	<b>A - 1</b>
513269900	<b>A - 1</b>
513269900	<b>A - 1</b>
513270000	<b>A - 1</b>
513270100	<b>A - 1</b>
513270200	<b>A - 1</b>
513270200	<b>A - 1</b>
513270300	<b>A - 1</b>
513270400	<b>A - 1</b>
513271200	<b>C - 3</b>
513271200	<b>C - 4</b>
513274900	<b>A - 1</b>
513275100	<b>A - 1</b>
513275200	<b>A - 1</b>
513275900	<b>A - 2</b>
513275900	<b>A - 3</b>
513276400	<b>A - 2</b>
513276400	<b>A - 3</b>

<b>Part no</b>	<b>Page no</b>
513277900	<b>C - 1</b>
513278000	<b>C - 2</b>
513278100	<b>C - 2</b>
513278200	<b>C - 2</b>
513278400	<b>B - 1C</b>
513280600	<b>A - 1</b>
513283600	<b>C - 2A</b>
513285000	<b>A - 1</b>
513286800	<b>A - 1</b>
513287000	<b>A - 1</b>
513287200	<b>A - 1</b>
513287200	<b>A - 1</b>
513290300	<b>C - 4</b>
513290300	<b>C - 4</b>
513290300	<b>C - 4</b>
513290400	<b>C - 4</b>
513290500	<b>C - 4</b>
513290600	<b>C - 4</b>
513290700	<b>B - 1C</b>
513291000	<b>A - 1</b>
513298900	<b>B - 1C</b>
513340800	<b>A - 1</b>
V2003037	<b>D - 1</b>
103S04C	<b>B - 1B</b>
104S01	<b>A - 1</b>
104S02	<b>A - 1</b>
104S03	<b>A - 1</b>
104S03	<b>A - 2</b>
104S03	<b>A - 3</b>
104S03	<b>B - 1A</b>
104S03	<b>B - 1B</b>
104S03	<b>B - 1C</b>
105S03	<b>C - 2</b>

<b>Part no</b>	<b>Page no</b>
105S04	<b>C - 2A</b>
105S05	<b>C - 4</b>
105S06	<b>C - 1</b>
105S06	<b>C - 2</b>
105S06	<b>C - 2A</b>
107S14	<b>B - 1B</b>
10S02	<b>A - 1</b>
10S02	<b>A - 3</b>
10S03	<b>A - 3</b>
10S03	<b>B - 1A</b>
10S03	<b>B - 1B</b>
10S03	<b>B - 1C</b>
10S04	<b>A - 1</b>
10S04	<b>A - 2</b>
10S04	<b>A - 3</b>
10S04	<b>B - 1A</b>
10S05	<b>A - 2</b>
10S05	<b>A - 3</b>
10S05	<b>A - 3</b>
10S06	<b>A - 2</b>
10S06	<b>A - 3</b>
10S09	<b>A - 1</b>
10S09	<b>B - 1B</b>
10S18	<b>B - 1B</b>
10S20	<b>A - 1</b>
10S73	<b>A - 3</b>
11S01B	<b>C - 3</b>
11S01C	<b>C - 5</b>
11S02A	<b>C - 3</b>
11S02A	<b>C - 4</b>
11S03B	<b>C - 1</b>
11S03B	<b>C - 2</b>
11S04C	<b>A - 1</b>

<b>Part no</b>	<b>Page no</b>
11S05C	<b>C - 2</b>
12S18	<b>C - 1</b>
12S18	<b>C - 2</b>
12S20	<b>C - 2</b>
12S20	<b>C - 2</b>
12S20	<b>C - 3</b>
12S23	<b>C - 1</b>
12S23	<b>C - 1</b>
12S23	<b>C - 2</b>
12S23	<b>C - 2</b>
12S23	<b>C - 3</b>
12S23	<b>C - 4</b>
15S01A	<b>D - 1</b>
16S06C	<b>C - 5</b>
17S02	<b>C - 3</b>
17S02	<b>C - 5</b>
17S03	<b>C - 3</b>
17S03	<b>C - 4</b>
17S05	<b>A - 1</b>
17S06	<b>C - 2</b>
17S06	<b>C - 4</b>
17S06	<b>C - 4</b>
188S04C2	<b>C - 2A</b>
188S04D2	<b>C - 3</b>
192S02	<b>A - 3</b>
192S05	<b>A - 1</b>
192S05	<b>A - 2</b>
192S05	<b>A - 3</b>
192S05	<b>C - 2A</b>
200S03E	<b>B - 1A</b>
200S03G	<b>A - 1</b>
200S03G	<b>A - 3</b>
200S03G	<b>B - 1A</b>

<b>Part no</b>	<b>Page no</b>
200S03G	<b>B - 1A</b>
203S04	<b>A - 3</b>
206S03C	<b>A - 1</b>
208S03F	<b>B - 1C</b>
267S03	<b>C - 5</b>
284S03E	<b>A - 3</b>
28S05G	<b>B - 1A</b>
30097A0140	<b>A - 2</b>
30097A0140	<b>A - 3</b>
30097A0213	<b>C - 3</b>
41S02	<b>A - 3</b>
41S03	<b>A - 1</b>
41S04	<b>A - 1</b>
41S04	<b>A - 3</b>
41S04	<b>B - 1B</b>
41S05	<b>A - 1</b>
41S05	<b>A - 2</b>
41S05	<b>A - 3</b>
41S05	<b>B - 1A</b>
41S05	<b>B - 1B</b>
41S05	<b>B - 1C</b>
41S07	<b>B - 1A</b>
44S02B	<b>A - 3</b>
44S03C	<b>A - 2</b>
44S03C	<b>A - 3</b>
44S03E	<b>A - 3</b>
44S03G	<b>A - 2</b>
44S03G	<b>A - 3</b>
44S05K	<b>A - 1</b>
54S01A	<b>B - 1B</b>
55S07Q	<b>B - 1B</b>
56S07	<b>C - 5</b>
56S13	<b>C - 3</b>

<b>Part no</b>	<b>Page no</b>
57S03D2	<b>C - 4</b>
57S05D2	<b>C - 1</b>
61S03	<b>C - 1</b>
61S03	<b>C - 2</b>
61S04	<b>C - 2</b>
61S04	<b>C - 2</b>
61S04	<b>C - 3</b>
61S05	<b>C - 1</b>
61S05	<b>C - 1</b>
61S05	<b>C - 2</b>
61S05	<b>C - 2</b>
61S05	<b>C - 3</b>
61S05	<b>C - 4</b>
66S02BB	<b>A - 1</b>
66S02CC	<b>A - 3</b>
66S02CC	<b>B - 1B</b>
66S03AA	<b>B - 1C</b>
66S03C	<b>A - 3</b>
66S03C	<b>B - 1C</b>
66S03CC	<b>A - 1</b>
66S03CC	<b>A - 1</b>
66S03CC	<b>B - 1B</b>
66S03D	<b>B - 1C</b>
66S05D	<b>B - 1A</b>
66S05D	<b>C - 2A</b>
69S03G	<b>A - 3</b>
69S03H	<b>A - 3</b>
69S03M	<b>A - 2</b>
69S03M	<b>A - 3</b>
69S05E	<b>A - 1</b>
69S05E	<b>A - 2</b>
69S05E	<b>A - 3</b>
6S02C	<b>A - 1</b>

<b>Part no</b>	<b>Page no</b>
6S02Z	<b>A - 1</b>
6S03E	<b>B - 1B</b>
6S03E	<b>C - 2A</b>
7S01	<b>A - 1</b>
7S01	<b>C - 3</b>
7S01	<b>C - 5</b>
7S02	<b>A - 1</b>
7S02	<b>C - 3</b>
7S02	<b>C - 4</b>
7S05	<b>C - 2</b>
7S05	<b>C - 4</b>
7S05	<b>C - 4</b>
7S05	<b>C - 4</b>
83S03	<b>A - 3</b>
87S02	<b>A - 1</b>
87S03	<b>C - 2A</b>
88S05D	<b>B - 1C</b>
88S07D	<b>B - 1A</b>
88S15D	<b>B - 1C</b>
88S20D	<b>B - 1A</b>
8S04E	<b>C - 2</b>
8S04F	<b>C - 3</b>
8S05C	<b>C - 3</b>
8S05D	<b>C - 4</b>
8S05E	<b>C - 1</b>
8S05F	<b>C - 2</b>
8S05H	<b>C - 1</b>
8S05H	<b>C - 2</b>
8S05H	<b>C - 4</b>
8S05J	<b>C - 1</b>
95S02	<b>A - 3</b>
97S12	<b>C - 1</b>
97S13	<b>C - 1</b>

<b>Part no</b>	<b>Page no</b>
97S13	<b>C - 2</b>
V2000772	<b>B - 1A</b>
V2003038	<b>D - 1</b>
V2003039	<b>D - 1</b>
V2003101	<b>D - 1</b>
V2003105	<b>D - 2</b>
V2003106	<b>D - 2</b>
V2003107	<b>D - 2</b>
V2003598	<b>D - 1</b>
V2003665	<b>D - 1</b>
V2004130	<b>D - 1</b>
V2004223	<b>D - 2</b>
V2004227	<b>D - 2</b>
V2004229	<b>D - 2</b>
V2004235	<b>D - 2</b>
V2004281	<b>D - 2</b>
V2004282	<b>D - 2</b>
V2004288	<b>D - 2</b>
V2004289	<b>D - 2</b>
V2004297	<b>D - 1</b>
V2004302	<b>D - 2</b>
V2004307	<b>D - 1</b>
V2004796	<b>D - 2</b>
V2005218	<b>D - 2</b>
V2005276	<b>D - 2A</b>
V2005311	<b>D - 2A</b>
V600164	<b>A - 3</b>
V601906	<b>D - 2</b>
V602436	<b>D - 2</b>
V602437	<b>D - 2</b>
V602438	<b>D - 2</b>
V602651	<b>C - 5</b>



# Mixers

100T

150T

175T

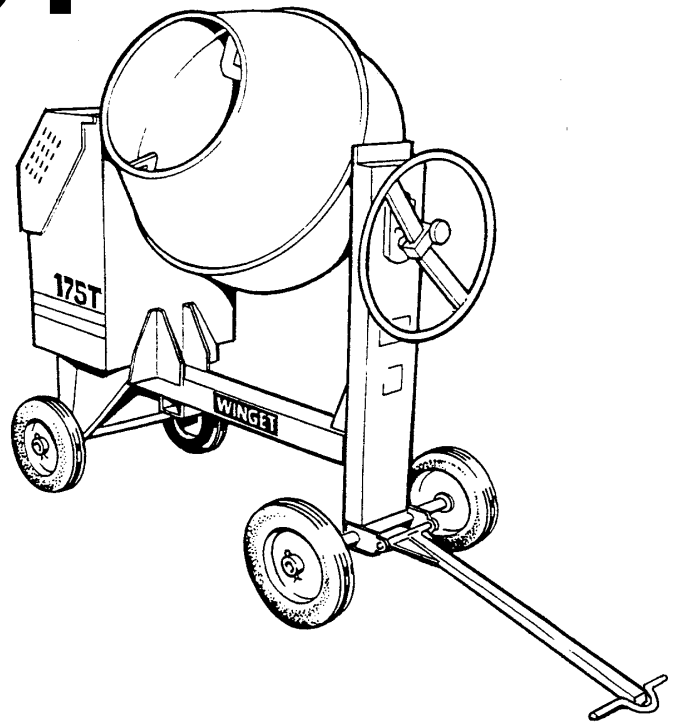
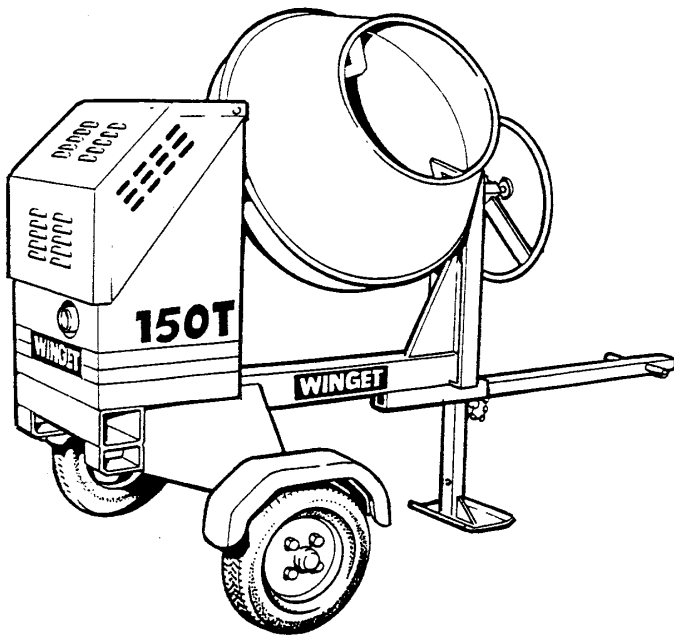



# Mixers built FROM February 1988

<b>FOUR WHEEL MAINFRAME (100T &amp; 150T)</b>	<b>A - 1A</b>
<b>MESH GUARDS (Honda engine)</b>	<b>A - 1AA</b>
<b>COVERS &amp; GUARDS (100T &amp; 150T)</b>	<b>A - 1B</b>
<b>FOUR WHEEL MAINFRAME (175T)</b>	<b>A - 2A</b>
<b>COVERS &amp; GUARDS (175T)</b>	<b>A - 2B</b>
<b>COVERS &amp; GUARDS (AC1-05 Electric start engine)</b>	<b>A - 3</b>
<b>TWO WHEEL MAINFRAME (100T &amp; 150T)</b>	<b>A - 4</b>
<b>TWO WHEEL MAINFRAME (175T)</b>	<b>A - 5</b>
<b>DRUM ASSEMBLY</b>	<b>B - 1A</b>
<b>TRUNNION &amp; TILT WHEEL</b>	<b>B - 1B</b>
<b>DRUM DRIVE</b>	<b>B - 1C</b>
<b>LISTER - PETTER LT1/LV1-32 (100T &amp; 150T)</b>	<b>C - 1</b>
<b>LISTER - PETTER LT1/LV1-10 (175T)</b>	<b>C - 1A</b>
<b>ELECTRIC DRIVE 110V/240V (100T) upto 2005</b>	<b>C - 2A</b>
<b>ELECTRIC DRIVE 110V/240V (150T) upto 2005</b>	<b>C - 2B</b>
<b>ELECTRIC DRIVE 110V/240V (175T) upto 2005</b>	<b>C - 2C</b>
<b>START SWITCHES (electric drive) upto 2005</b>	<b>C - 3</b>
<b>LISTER - PETTER AC1 (electric start)</b>	<b>C - 4</b>
<b>YANMAR L40/L48ARESE/L48N5SJ1 (electric start)</b>	<b>C - 5</b>
<b>YANMAR L48V5V STAGE 5 Emission Compliant (electric start)</b>	<b>C - 5A</b>
<b>STARTING CIRCUIT, YanmarL40/L48 ARESE/L48N5SJ1/L48V5V</b>	<b>C - 6</b>
<b>STOP CABLE, Yanmar L48N5SJ1/L48V5V</b>	<b>C-6A</b>
<b>HONDA GX160K1 (recoil/hand start)</b>	<b>C - 7</b>
<b>DECALS &amp; PLATES</b>	<b>D - 1</b>
<b>SPECIAL TOOLS</b>	<b>D - 3</b>



# A - 1A

## 100T & 150T Mixers from February 1988

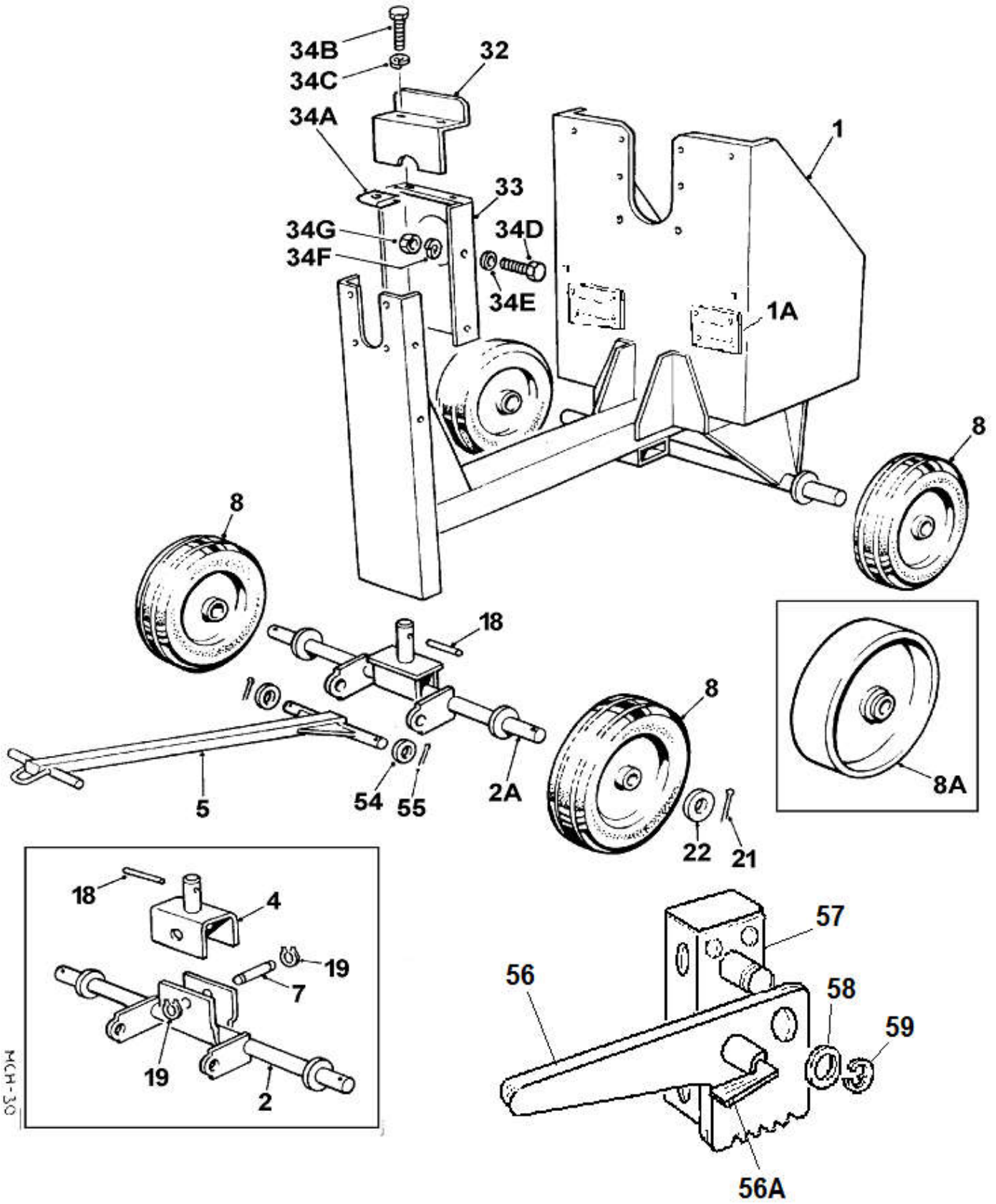

MCH-30

# FOUR WHEEL MAINFRAME & TOW BAR

# A - 1A

Item	Part no	Serial no	Description	Qty
1	513340900		MAINFRAME, <b>100T</b> (Not Honda eng.)	1
1	513363900		MAINFRAME, <b>100T</b> (With Honda eng.)	1
1	513341000		MAINFRAME, <b>150T</b>	1
1A	513371700	11752/ <b>100T</b> 05813/ <b>150T</b>	PLATE, vent, Yanmar L48V5V	2
1B	11S02A		SCREW, set	8
1C	17S03		WASHER, spring	8
2	513341100	/ 05641	AXLE, front, <b>100T</b>	1
2A	513358100	05642 /	AXLE, front, <b>100T</b>	1
2	513341100	/ 01725	AXLE, front, <b>150T</b>	1
2A	513358100	01726 /	AXLE, front, <b>150T</b>	1
4	513154500	/ 05641	SWIVEL, front axle, <b>100T</b>	1
4	513154500	/ 01725	SWIVEL, front axle, <b>150T</b>	1
5	513341200		TOWBAR	1
7	513155000	/ 05641	PIN, pivot, front axle, <b>100T</b>	1
7	513155000	/ 01725	PIN, pivot, front axle, <b>150T</b>	1
8	475106000	<b>100T</b> /06312	WHEEL, cushion tyre, 355mm (14") dia	4
8	475106000	<b>150T</b> /02311	WHEEL, cushion tyre, 355mm (14") dia	4
8	475115000	06313/ <b>100T</b>	WHEEL, cushion tyre, 405mm dia	4
8	475115000	02312/ <b>150T</b>	WHEEL, cushion tyre, 405mm dia	4
<b>Alternative wheel</b>				
8A	513198500		WHEEL, steel, 400x100mm (16" x 4") (Obsolete, no longer available)	4
18	353830650		PIN, spirol	1
19	132412010	/ 05641	CIRCLIP, <b>100T</b>	2
19	132412010	/ 01725	CIRCLIP, <b>150T</b>	2
20	10S09		WASHER, flat	4
21	44S05G		PIN, split	4
-	513198400		GUARD, tilt wheel, assembly	1
32	513198402		GUARD, upper	1
33	513198401		GUARD, lower	1
34A	332719000	/ June-96	NUT, captive ( Replaced by rivet nuts in guard )	2
34B	11S02B		SCREW, set	2
34C	17S03		WASHER, spring	2
34D	66S03CC		SCREW, set	4
34E	10S03		WASHER, flat	4

continued>>>

# A - 1A

100T & 150T Mixers from February 1988

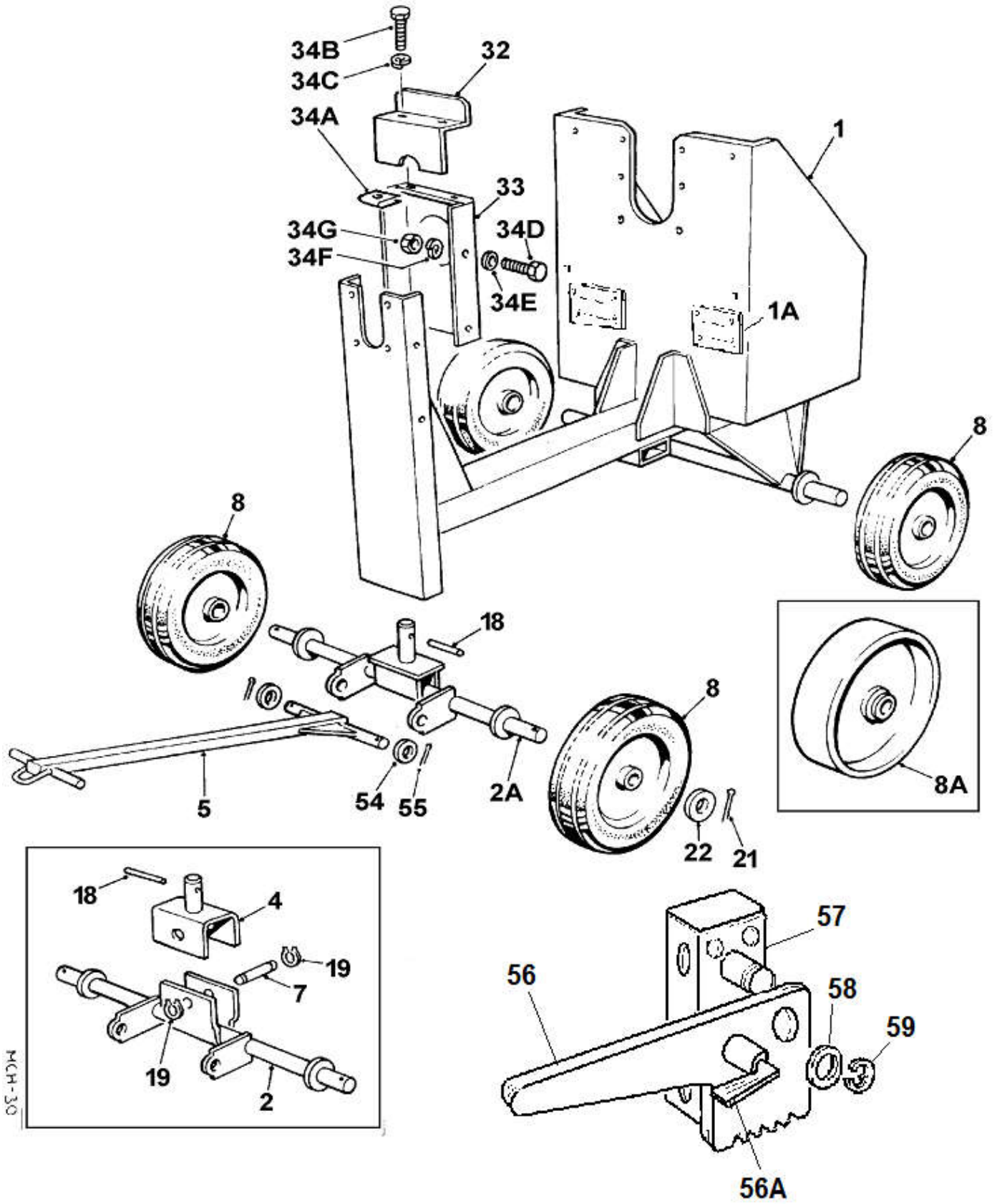

# FOUR WHEEL MAINFRAME & TOW BAR

# A - 1A

Item	Part no	Serial no	Description	Qty
34F	41S05		WASHER, spring	4
34G	104S03		Nut	4
54	10S17		WASHER, flat	2
55	44S03D		PIN, split	2
		11195 /	<b>100T</b>	
		05637 /	<b>150T</b>	
56	513370700		LEVER, handbrake, assembly	1
56A	513370800		CATCH, sprung	1
57	513370600		PIVOT, bracket	1
57A	11S04C		SCREW, set, not illustrated	2
57B	17S05		WASHER, spring, not illustrated	2
57C	267S06		WASHER, flat, not illustrated	2
58	10S18		WASHER, flat	1
59	132412010		CIRCLIP	1

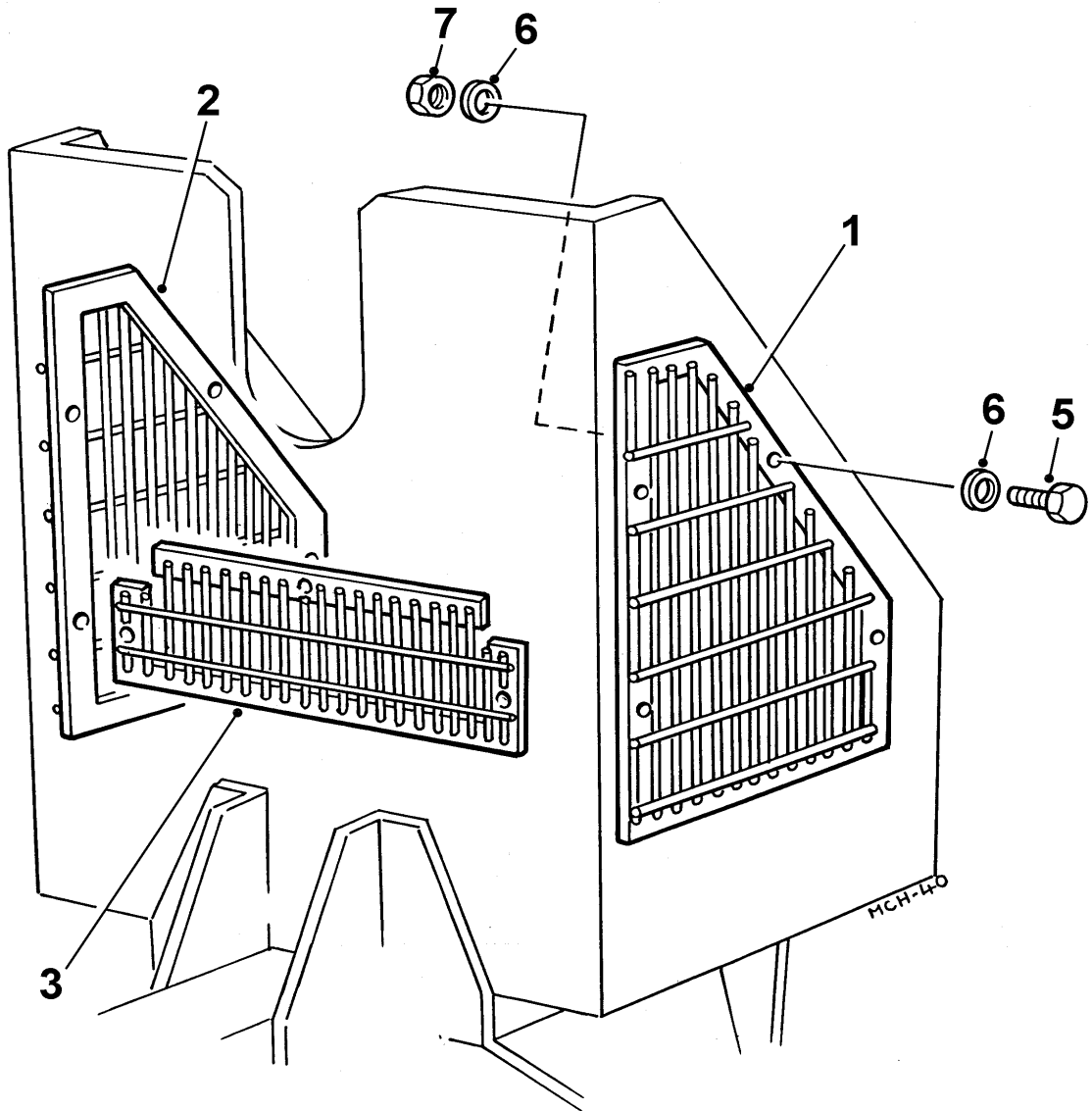

**MESH GUARDS****A - 1AA**

<b>Item</b>	<b>Part no</b>	<b>Serial no</b>	<b>Description</b>	<b>Qty</b>
1	513364300		GUARD, mesh, L.H.	1
2	513364400		GUARD, mesh, R.H.	1
3	513364500		GUARD, mesh, rear	1
5	11S02B		SCREW, set	11
6	267S04		WASHER, flat	22
7	61S02		NUT, self locking	11

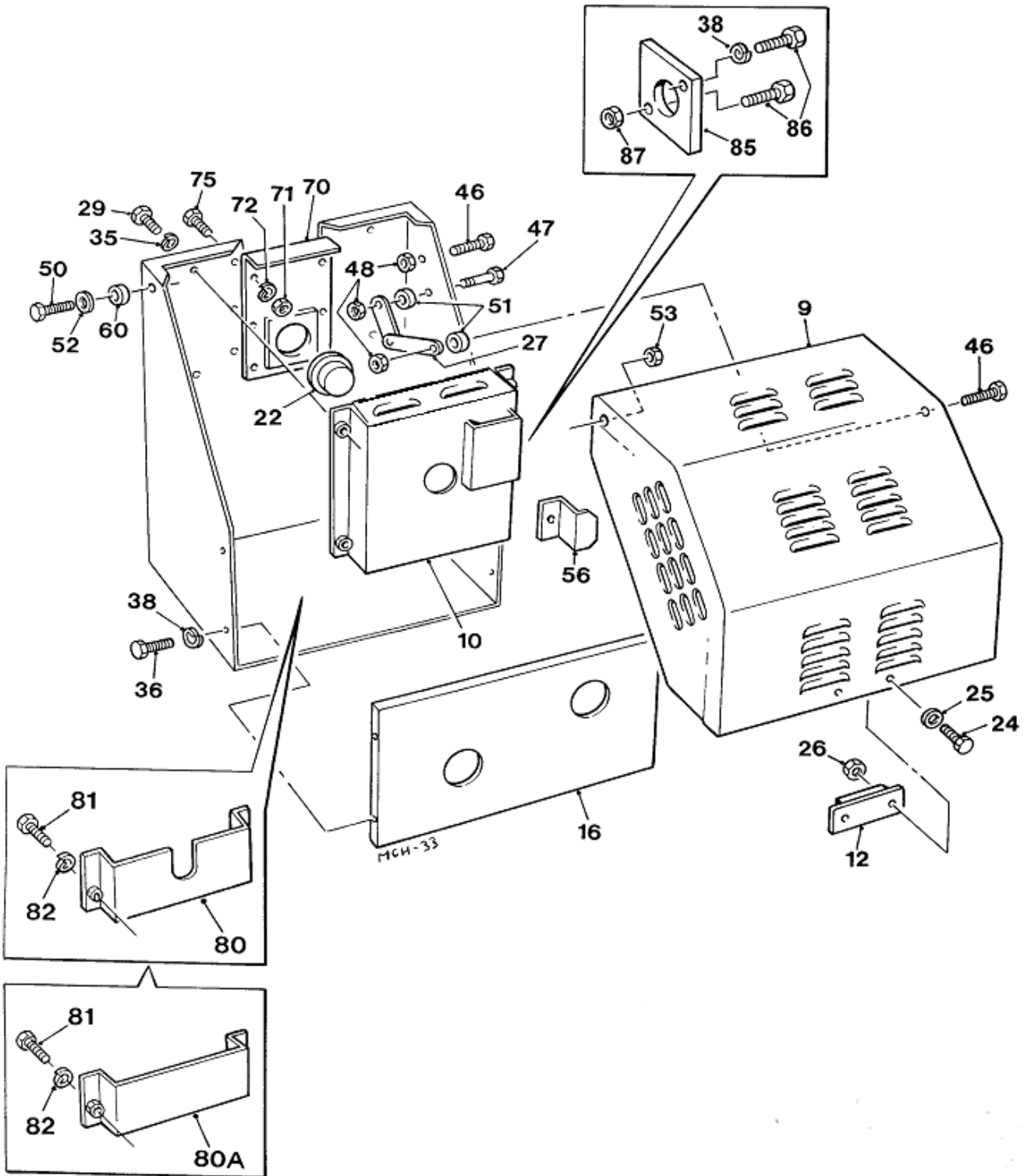

# COVERS & GUARDS

# A - 1B

Item	Part no	Serial no	Description	Qty
9	513341300		LID, engine housing	1
10	513341400	/11751/05854	GUARD, chain/belt not Yanmar L48V5V	1
10	513371600	11752/	GUARD, belt, 100T, Yanmar L48V5V	1
10	513371500	05855/	GUARD, belt, 150T, Yanmar L48V5V	1
12	V2003109		STOP, rubber ( <i>screw-in bobbin</i> )	2
12	513205300		STOP, rubber ( <i>two screw block</i> )	1
16	513341500		PLATE, <b>100T</b> , ( <i>Not Honda engine</i> )	1
16	513364100		PLATE, <b>100T</b> , ( <i>With Honda engine</i> )	1
16	513341600		PLATE, <b>150T</b>	1
22	241859000		PLUG, polythene	1
24	11S02A		SCREW, set	2
25	267S04		WASHER, flat	2
26	61S02		NUT, Binx, self-locking	2
27	513287200		STAY, housing lid	1
29	11S02B		SCREW, set	4
35	17S03		WASHER, spring	4
36	11S02B		SCREW, set	4
38	17S03		WASHER, spring	4
46	28S02E		SCREW, set, <i>obsolete use</i>	2
46	11S03D		SCREW, set	2
47	6S02E		BOLT, <i>obsolete use</i>	1
47	8S03E		BOLT	1
48	87S02		NUT, binx, self-locking, <i>obsolete use</i>	3
48	61S03		NUT, binx, self locking	3
50	11S04E		SCREW, set	2
51	513340800		SPACER	2
52	267S06		WASHER, flat	4
53	7S04		NUT	2
56	513285000	/ 05641	BRACKET, starting handle, <b>100T</b>	1
56	513285000	/ 01725	BRACKET, starting handle, <b>150T</b>	1
56	.....		( <i>Not used with Yanmar or Honda engines</i> )	
60	555170000		SPACER	2
70	513151800		BRACKET, trunnion	1
71	104S03		NUT	6
72	41S05		WASHER, spring	6
75	66S03CC		SCREW, set	6
80	513355800		GUARD, ( <i>electric motors only</i> )	1
80A	513362400	#	GUARD,( <b>150T</b> with Yanmar eng ) Not Yanmar L48V5V	1
81	11S02A		SCREW, set	2
82	17S03		WASHER, spring	2

continued>>>



**A - 1B**

**100T & 150T Mixers from February 1988**

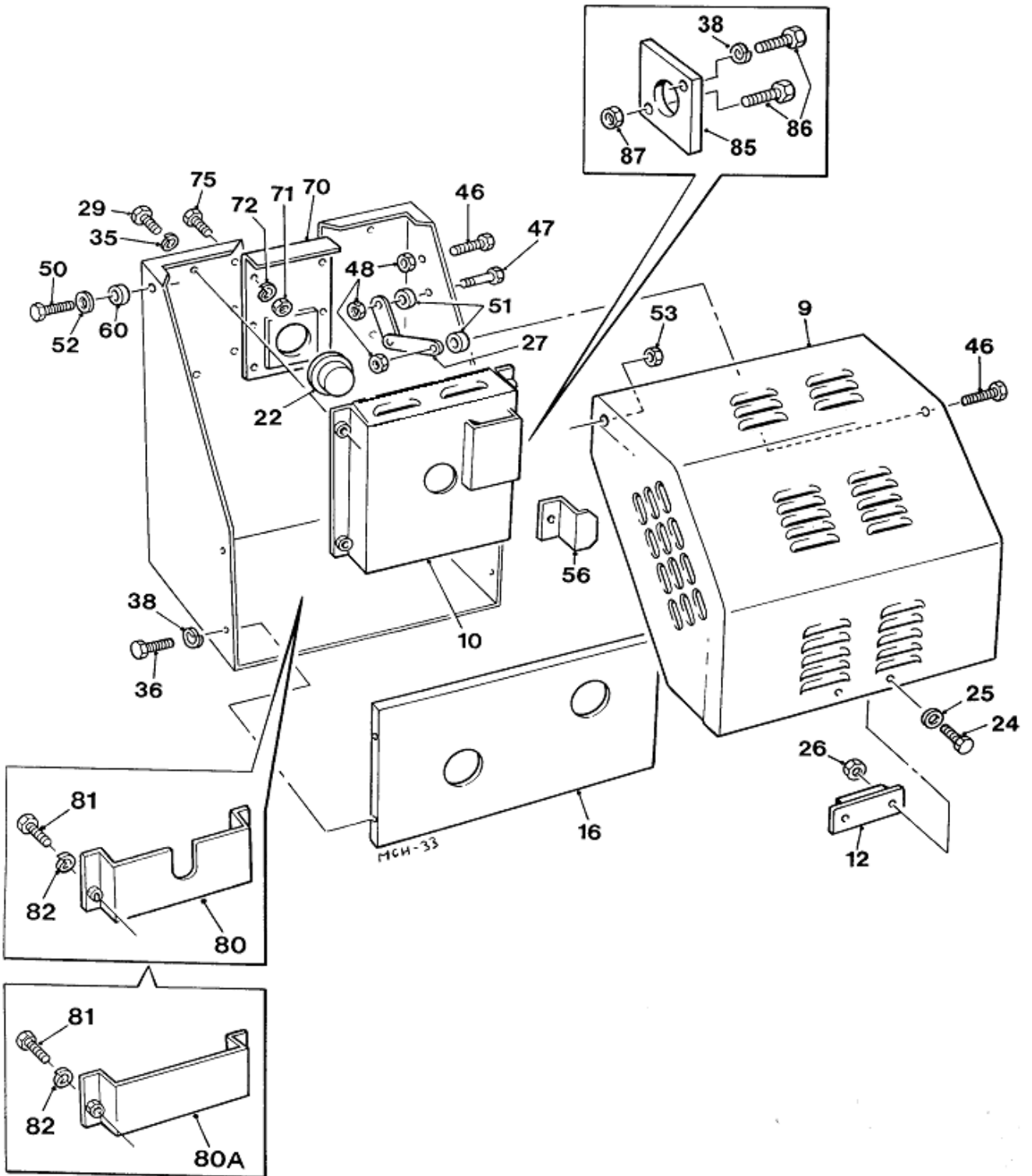

**COVERS & GUARDS****A - 1B**

<b>Item</b>	<b>Part no</b>	<b>Serial no</b>	<b>Description</b>	<b>Qty</b>
		06737 /	# <b>100T</b> <i>(with Yanmar &amp; Honda engines only)</i>	
		02719 /	# <b>150T</b> <i>(with Yanmar engines only)</i>	
85	513362600	/	# PLATE, rope guide	1
86	11S02C	/	# SCREW, set	2
87	61S02	/	# NUT, Binx	1/2

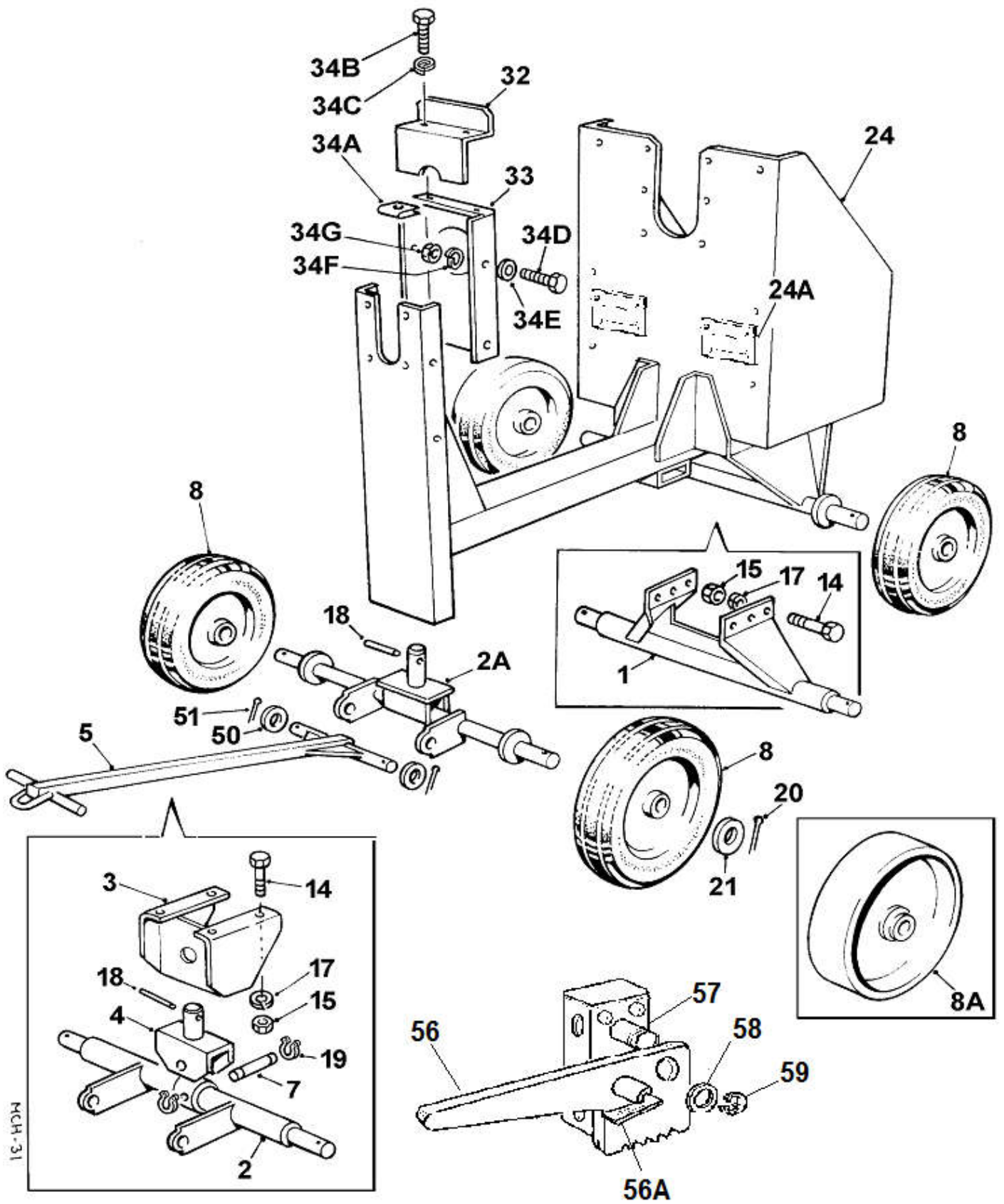

# FOUR WHEEL MAINFRAME & TOW BAR

A - 2A

Item	Part no	Serial no	Description	Qty
1	513275200	/ 01725	AXLE, rear	1
2	513203400	/ 01725	AXLE, front	1
2A	513358100	01726 /	AXLE, front	1
3	513274900	/ 01725	BRACKET, front axle swivel	1
4	513154500	/ 01725	SWIVEL, front axle	1
5	513341200		TOWBAR	1
7	513155000	/ 01725	PIN, pivot, front axle	1
8	475106000	/ 02277	WHEEL, cushion tyre, 355mm (14") dia	4
8	475115000	02282 /	WHEEL, cushion tyre, 405mm (16") dia	4
<b>Alternative wheel</b>				
8A	513198500		WHEEL, steel, 400x100mm (16" x4") (Obsolete, no longer available)	4
14	69S05E		BOLT	10
15	192S05		NUT	10
17	10S04		WASHER, flat	10
18	353830650		PIN, spirol	1
19	132412010	/ 01725	CIRCLIP	2
20	44S05G		PIN, split	4
21	10S09		WASHER, flat	4
24	513269400		MAINFRAME	1
24A	513371700	05811/	PLATE, vent, Yanmar L48V5V	2
24B	11S02A		SCREW, set	8
24C	17S03		WASHER, spring	8
-	513198400		GUARD, tilt wheel, assembly	1
32	513198402		GUARD, upper	1
33	513198401		GUARD, lower	1
34A	332719000	/ June-96	NUT, captive ( Replaced by rivet nuts in guard)	2
34B	11S02B		SCREW, set	2
34C	17S03		WASHER, spring	2
34D	66S03CC		SCREW, set	4
34E	10S03		WASHER, flat	4
34F	41S05		WASHER, spring	4
34G	104S03		NUT	4
50	10S17		WASHER, flat	2
51	44S03D		PIN, split	2

continued>>>

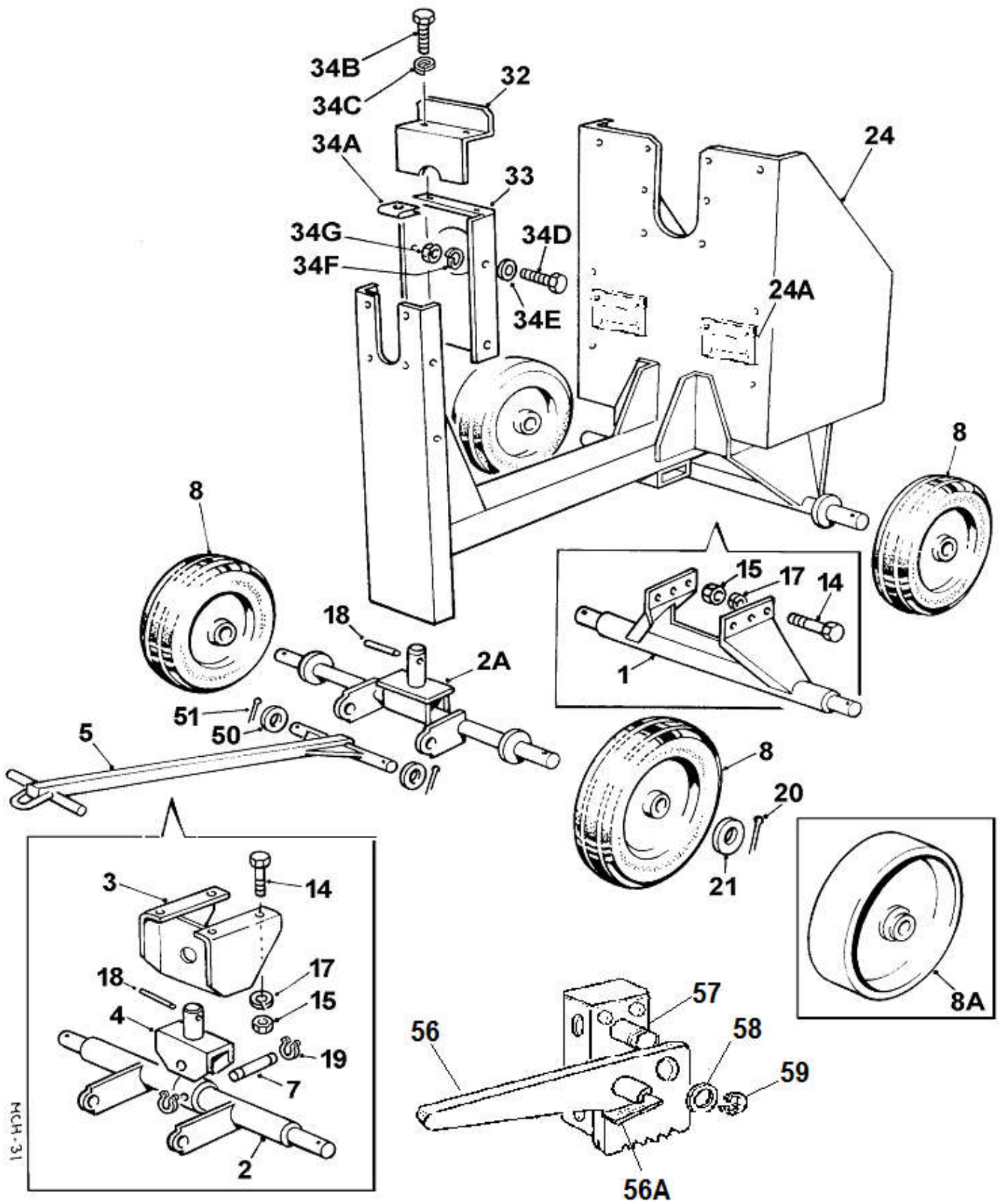

MCB-31

**FOUR WHEEL MAINFRAME & TOW BAR****A - 2A**

<b>Item</b>	<b>Part no</b>	<b>Serial no</b>	<b>Description</b>	<b>Qty</b>
		05604 /	<b>175T</b>	
56	513370700		LEVER, handbrake, assembly	1
56A	513370800		CATCH, sprung	1
57	513370600		PIVOT, bracket	1
57A	11S04C		SCREW, set, not illustrated	2
57B	17S05		WASHER, spring, not illustrated	2
57C	267S06		WASHER, flat, not illustrated	2
58	10S18		WASHER, flat	1
59	132412010		CIRCLIP	1

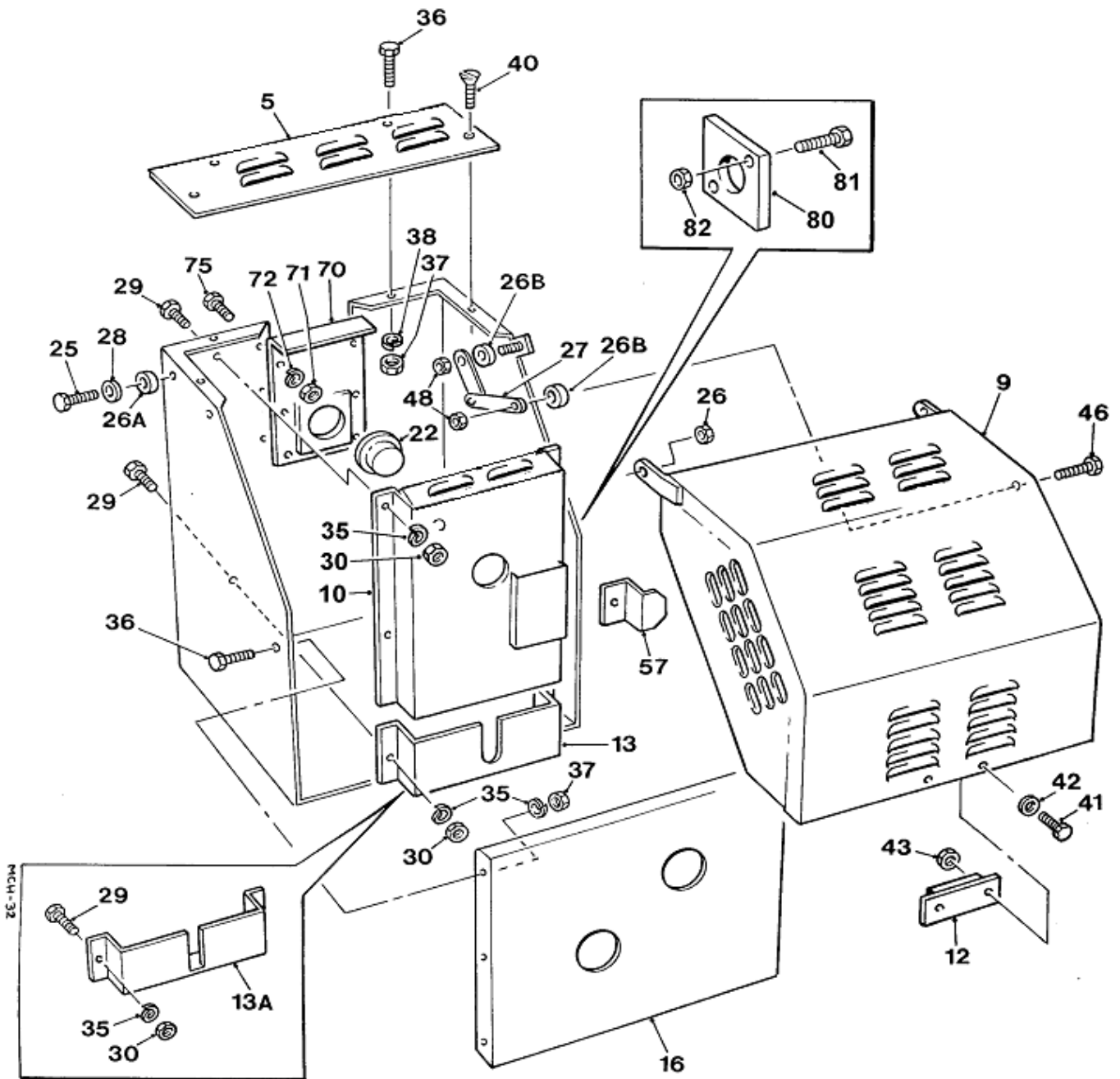

## COVERS &amp; GUARDS

## A - 2B

Item	Part no	Serial no	Description	Qty
5	513287000		TOP PLATE, engine housing	1
9	513286800		LID, engine housing	1
10	513248700	/05810	GUARD, chain/belt	1
10	513371400	05811/	GUARD, belt Yanmar L48V5V	1
12	V2003109		STOP, rubber (round screw-in bobbin)	1
12	513205300		STOP, rubber (two screw block)	1
13	513266900		GUARD, sprocket, <b>diesel engine, LT/LV</b>	1
13A	513205600		GUARD, sprocket, <b>electric motor</b>	1
16	513270300		PLATE, closing	1
22	241859000		PLUG, polythene	1
25	11S04E		SCREW, set	2
26	7S04		NUT	2
26A	555170000		SPACER	2
26B	513340800		SPACER	2
27	513287200		STAY, housing lid	1
28	267S06		WASHER, flat	2
29	66S03CC		SCREW, set	6
30	104S03		NUT	6
35	41S05		WASHER, spring	12
36	11S02A		SCREW, set	2
36A	66S03CC		SCREW, set	6
37	7S02		NUT	4
37A	104S03		NUT	6
38	17S03		WASHER, spring	4
40	52S02C		SCREW, c'sunk socket head	2
41	11S02A		SCREW, set	2
42	267S04		WASHER, flat	2
43	61S02		NUT, Binx, self-locking	2
46	6S02E		BOLT, obsolete use	1
46	8S03E		BOLT	1
48	87S02		NUT, binx, self locking, obsolete use	2
48	61S03		NUT, binx, self locking	2
57	513285000		BRACKET, starting handle, LT/LV	1
70	513151800		BRACKET, trunnion	1
71	104S03		NUT	6
72	41S05		WASHER, spring	6
75	66S03CC		SCREW, set	6
80	513362600	02719 /	PLATE, <i>rope guide(Yanmar engines)</i>	1
81	11S02C	02719 /	SCREW, set	2
82	61S02	02719 /	NUT, Binx	2



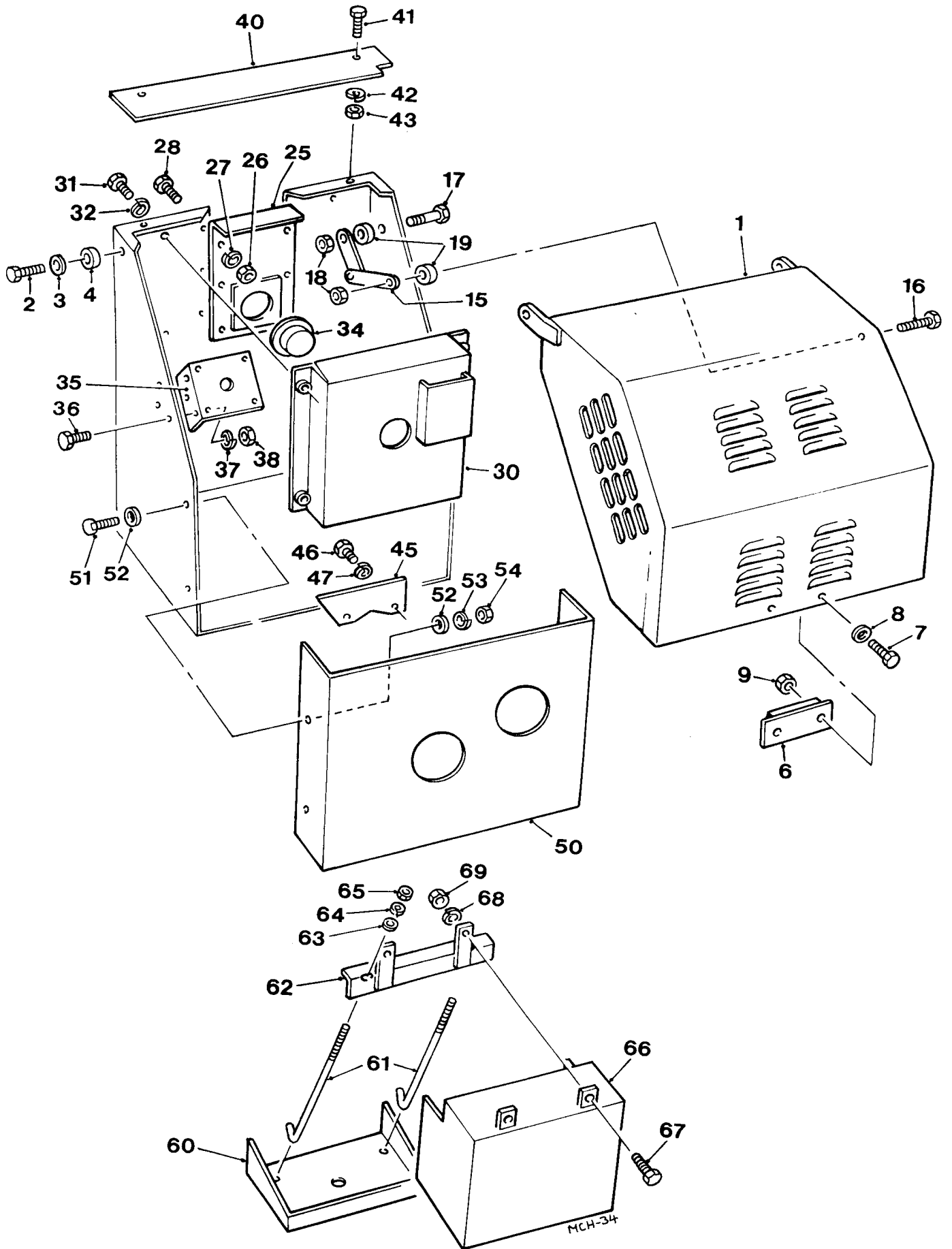

**COVERS & GUARDS (Lister-Petter AC1-05 Electric Start) A - 3**

Item	Part no	Serial no	Description	Qty
1	513286800		LID, engine housing	1
2	11S04C		SCREW, set	2
3	267S06		WASHER, flat	2
4	555170000		SPACER	2
6	513205300		STOP, rubber	1
7	11S02A		SCREW	2
8	267S04		WASHER, flat	2
9	61S02		NUT, Binx	2
15	513287200		STAY, housing lid	1
16	6S02E		BOLT	1
17	28S02E		SCREW, set	1
18	87S02		NUT, Binx	2
19	513340800		SPACER	2
25	513151800		BRACKET, trunnion	1
26	104S03		NUT	6
27	41S05		WASHER, spring	6
28	66S03CC		SCREW, set	6
30	513341400		GUARD, chain	1
31	11S02A		SCREW, set	4
32	17S03		WASHER, spring	4
34	241859000		PLUG, polythene	1
35	513359200		BRACKET, start switch	1
36	11S03A		SCREW, set	3
37	17S04		WASHER	3
38	7S03		NUT	3
40	513358900		PLATE, top infill	1
41	11S02A		SCREW, set	2
42	17S03		WASHER, spring	2
43	7S02		NUT	2
45	513359100		PLATE, belt guard	1
46	66S03C		SCREW, set	1
47	41S05		WASHER, spring	1
50	513358400		PLATE, closing	1
51	11S02A		SCREW, set	4
52	267S04		WASHER, flat	8
53	17S03		WASHER, spring	4
54	7S02		NUT	4

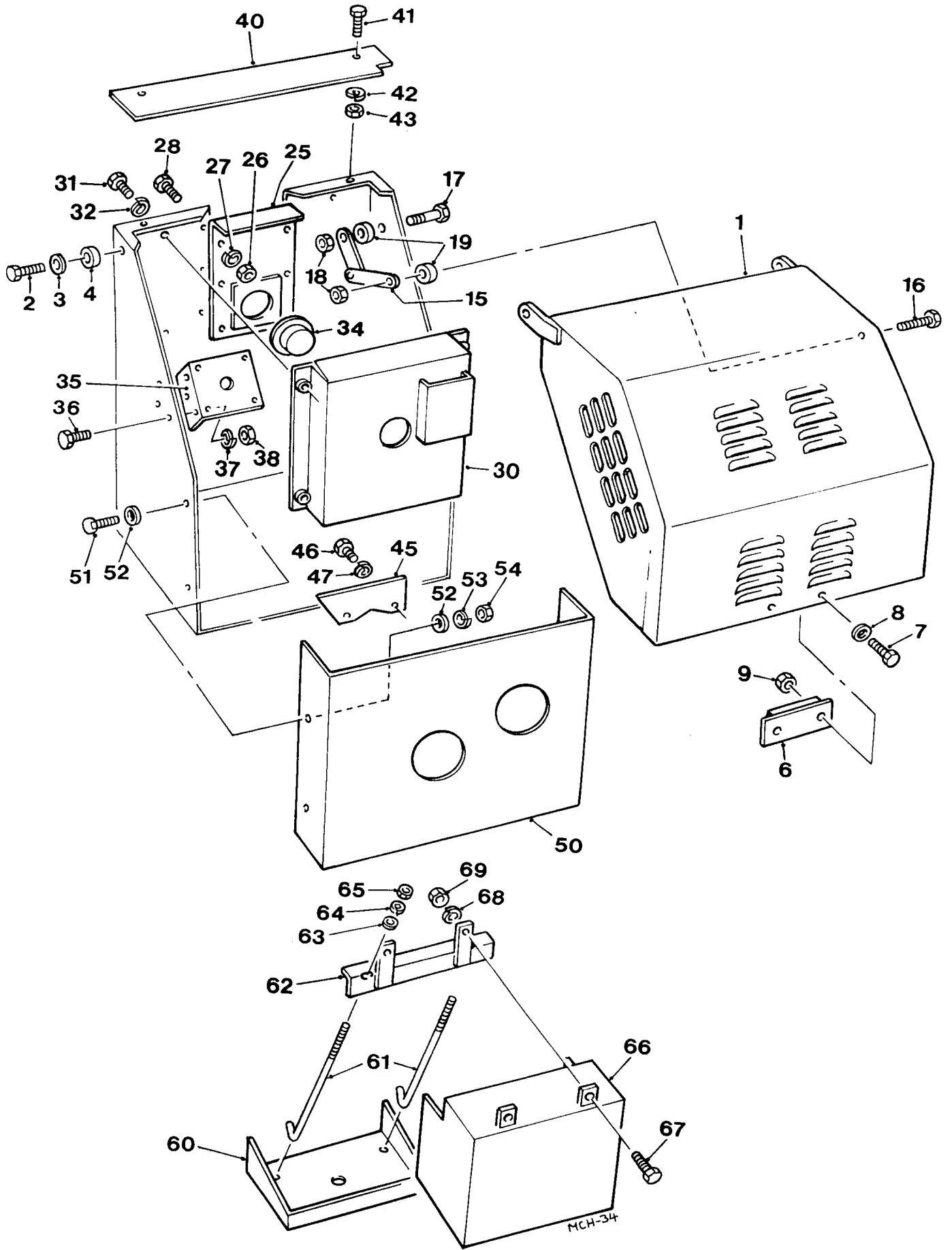

# COVERS & GUARDS (Lister-Petter AC1-05 Electric Start) A - 3

---

Item	Part no	Serial no	Description	Qty
------	---------	-----------	-------------	-----

---

**Continued>>>**

60	513358500		BRACKET, battery (welded to chassis)	1
61	V2004120		ROD	2
62	V2004055		CLAMP	1
63	267S04		WASHER, flat	2
64	17S03		WASHER, spring	2
65	7S04		NUT	2
66	513358600		COVER, battery	1
67	11S04B		SCREW, set	2
68	17S05		WASHER, spring	2
69	7S04		NUT	2

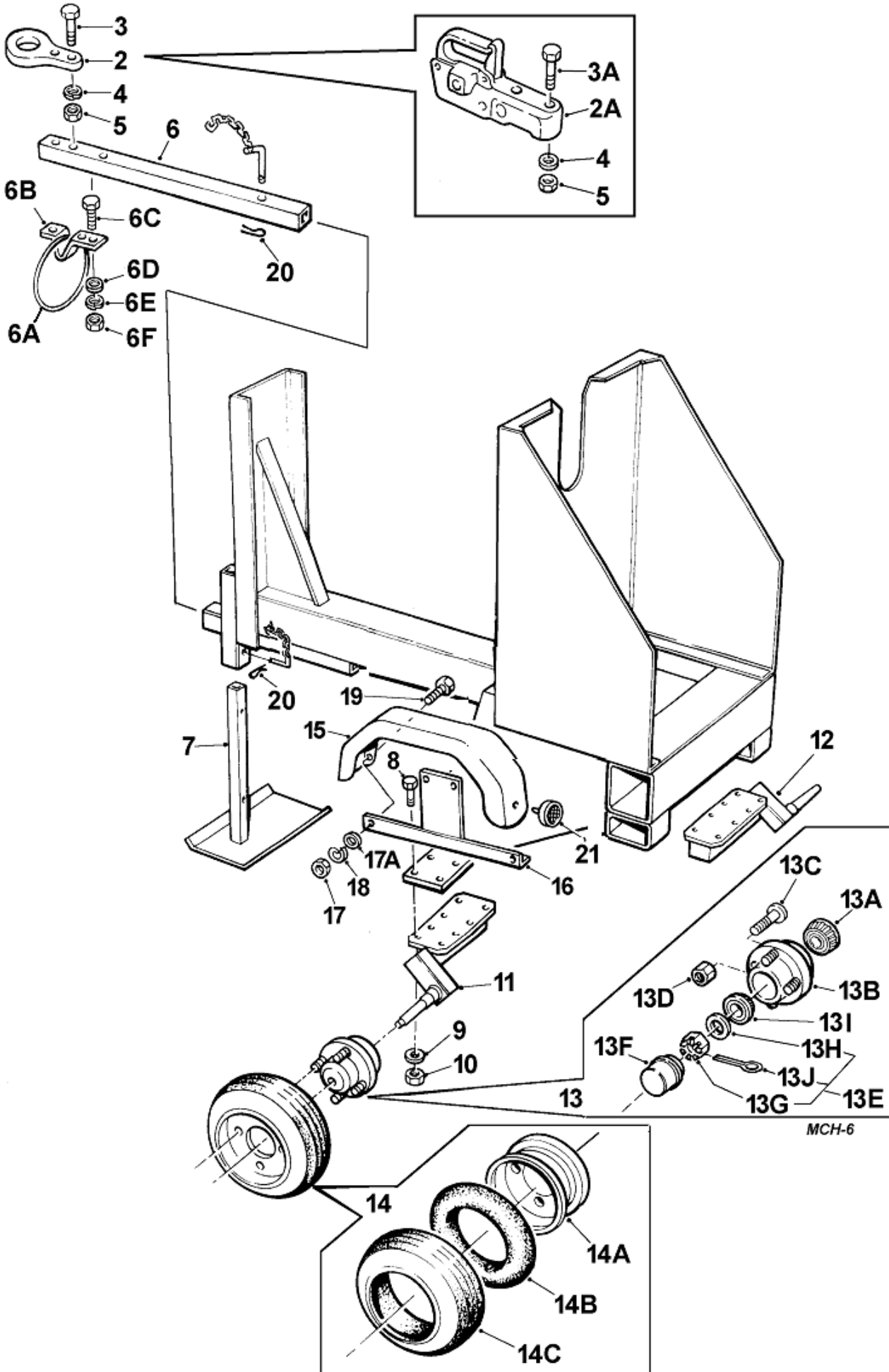

**TWO WHEEL MAINFRAME & TOW BAR**

**A - 4**

Item	Part no	Date	Description	Qty
-	513342200		MAINFRAME, assembly, <b>100T</b>	1
-	513342300		MAINFRAME, assembly, <b>150T</b>	1
1	513344200		MAINFRAME, <b>100T</b>	1
1	513344300		MAINFRAME, <b>150T</b>	1
2	513344000		EYE, towing	1
2A	513364700	Nov-03 /	COUPLING, towing	1
3	8S04E		BOLT	2
3A	8S04L	Nov-03 /	BOLT	2
4	267S06		WASHER, spring	2
5	59S03		NUT	2
6	513343800		ARM, towing, adjustable	1
6A	V2004765		CABLE, breakaway, towbar	1
6B	V2004765A		SUPPORT, towbar	1
6C	11S04C		SCREW, set	3
6D	267S06		WASHER, flat	3
6E	17S05		WASHER, spring	3
6F	7S04		NUT	3
7	513343900		LEG, adjustable	1
8	8S03B		BOLT	16
9	267S05		WASHER, flat	16
10	61S03		NUT, locking	16
11	475130300		# SUSPENSION UNIT, L.H.	2
12	475130400		# SUSPENSION UNIT, R.H.	2
13	475130200		# HUB, wheel, assembly	2
13A	V600149		KIT, bearing	2
13B	V600150		HUB	1
13C	V600151		\$ KIT, stud, imperial 3/8" UNF	set of 4
13C	V603612		\$ KIT, stud, metric M10 fine	set of 4
13D	V600152		\$ KIT, nut, imperial 3/8" UNF	set of 4
13D	V603611		\$ KIT, nut, metric M10 fine	set of 4
			\$ <i>When ordering state whether "Metric" or "Imperial"</i>	
13E	V600153		KIT, fastening	1
13F	V600154		CAP	1
13G	216S08		NUT, "metric"	1
13G	92S07		NUT, "imperial"	1
13H	10S05		WASHER	1
13I	475117006		BEARING	1
13J	44S03C		PIN, split	1
14	475117021		# WHEEL, assembly	2
14A	V600155		RIM, wheel	1
14B	475117008		TUBE, inner	1
14C	475117007		TYRE	1

# Items 11, 12, 13, & 14 are supplied as part of kit suspension. Part number 513343700

A - 4

100T & 150T Mixers from February 1988

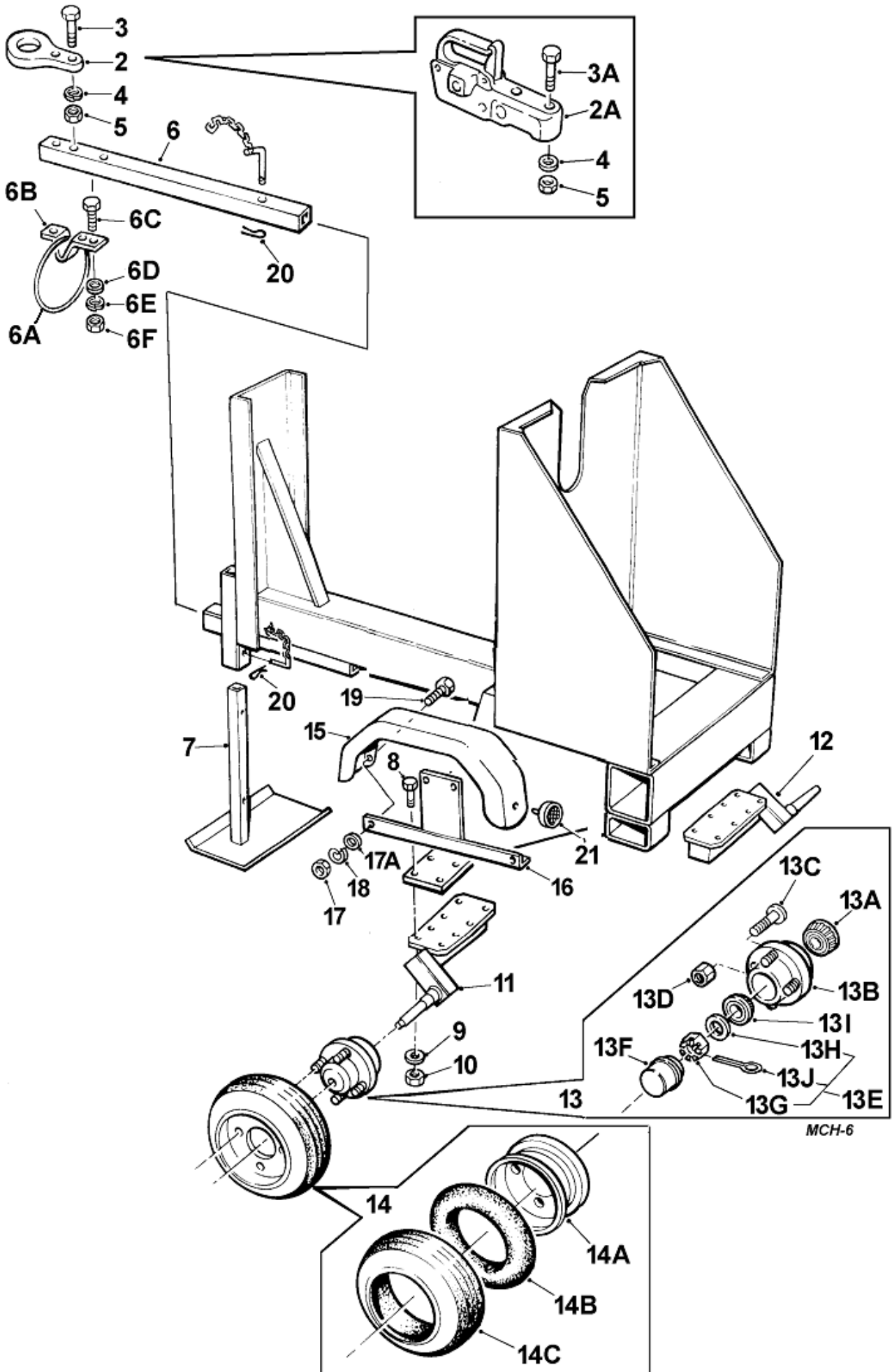

## TWO WHEEL MAINFRAME & TOW BAR

A - 4

Item	Part no	Serial no	Description	Qty
15	513167900	804120 /	MUDGUARD	2
16	513345700	804120 Sept '16	BRACKET, mudguard	2
16	513345700	Sept '16 /	BRACKET, mudguard	2
17	104S03	804120 /	NUT	6/8
17A	V2004220	Sept '16 /	WASHER, flat	4
18	41S05	804120 /	WASHER, spring	6/8
19	200S03E	804120 /	SCREW, round head	6/8
20	902S02	804120 /	PIN, lynch	2
21	386102000	804120 /	REFLECTOR, red, non triangular, rear of mudguard, not EU from serial nos below	2

***Following parts are not illustrated***

***From serial nos 100T-09456, 150T-05103***

22	386103000		REFLECTOR, white, non triangular front of mudguard	2
22A	513369300S		BRACKET, reflector, white, straight	2
22B	11S01A		SCREW, set	4
22C	267S03		WASHER, flat	6
22D	59S13		NUT, nyloc	4
23	386104000		REFLECTOR, amber, non triangular top of mudguard	2
23A	513369300F		BRACKET, reflector, amber, folded	2
23B	11S01A		SCREW, set	4
23C	267S03		WASHER, flat	6
23D	59S13		NUT, nyloc	4
24	V2006349		BOARD, lighting	1
24A	513369700		BUSH, flanged, plastic	4
25	513369600		PLATE, lighting board mounting	1
25A	8S04F		BOLT, plate retaining	2
25B	V2004220		WASHER, special	4
25C	59S03		NUT, nyloc	2
26	V2006351		NUT, winged	2
27	267S06		WASHER, flat	2

***From serial nos 100T-11752, 150T-05813***

28	513371700		PLATE, vent, Yanmar L48V5V <i>Not illustrated</i>	2
29	11S02A		SCREW, set	8
30	17S03		WASHER, spring	8



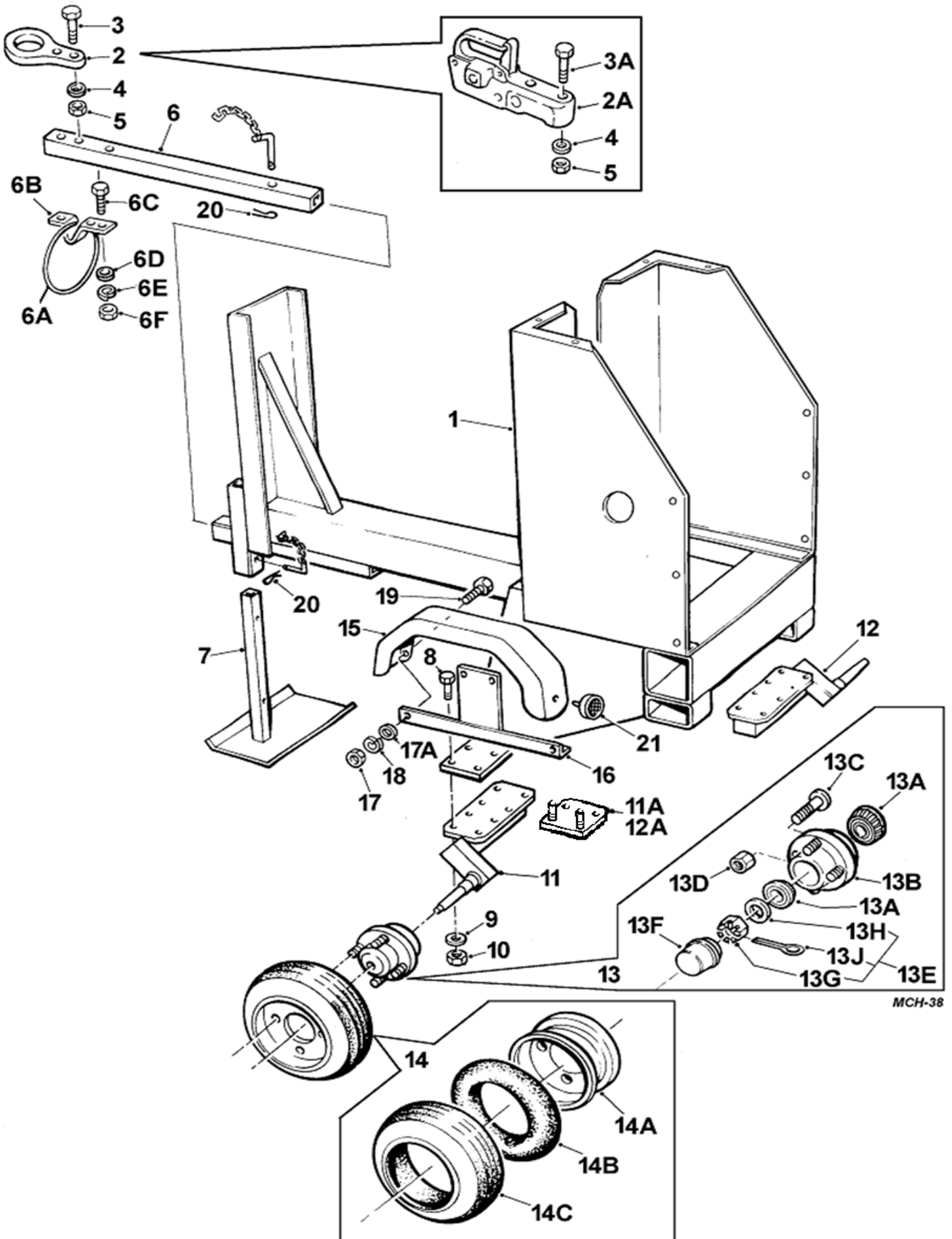

**TWO WHEEL MAINFRAME & TOW BAR**

Item	Part no	Serial no	Description	Qty
.....	513345100	02184 /	MAINFRAME, assembly	
1	513360200		MAINFRAME, <b>175T FT</b>	1
2	513344000		EYE, towing	1
2A	513364700	Nov-03 /	COUPLING, towing	1
3	8S04E		BOLT	2
3A	8S04L	Nov-03 /	BOLT	2
4	267S06		WASHER, spring	2
5	59S03		NUT	2
6	513343800		ARM, towing, adjustable	1
6A	V2004765		CABLE, breakaway, towbar	1
6B	V2004765A		SUPPORT, towbar	1
6C	11S04C		SCREW, set	3
6D	267S06		WASHER, flat	3
6E	17S05		WASHER, spring	3
6F	7S04		NUT	3
7	513343900		LEG, adjustable	1
8	11S05E		SCREW, set	16
8A	11S05F	05250/	SCREW, set, <i>use with 11A &amp; 12A</i>	4
9	267S07		WASHER, flat	16
10	61S05		NUT, locking	16
11	475130500		SUSPENSION UNIT, L.H.	2
<i>Peak Dynamic Suspension units with a longer radius arm introduced from S/No 05250. If replacing earlier units with Peak they must be replaced in pairs</i>				
11A	513370200	05250/	BRACKET, mudguard LH (PEAK SUS)	1
11B	59S04	05250/	NUT, nyloc	2
11C	267S07	05250/	WASHER, flat	2
12	475130600		SUSPENSION UNIT, R.H.	2
<i>Peak Dynamic Suspension units with a longer radius arm introduced from S/No 05250. If replacing earlier units with Peak they must be replaced in pairs</i>				
12A	513370100	05250/	BRACKET, mudguard RH (PEAK SUS)	1
12B	59S04	05250/	NUT, nyloc	2
12C	267S07	05250/	WASHER, flat	2
13	475130800		HUB, wheel, assembly	2
13A	V602718		KIT, bearing	2
13B	V602719		HUB	1
13C	V602721		KIT, stud	4
13D	V602720		KIT, wheel nut	4
13E	V600153		KIT, fastening	1
13F	V602722		CAP	1
13G	216S08		NUT, "metric"	1
13G	92S07		NUT, "imperial"	1
13H	10S05		WASHER	1
13J	44S03C		PIN, split	1

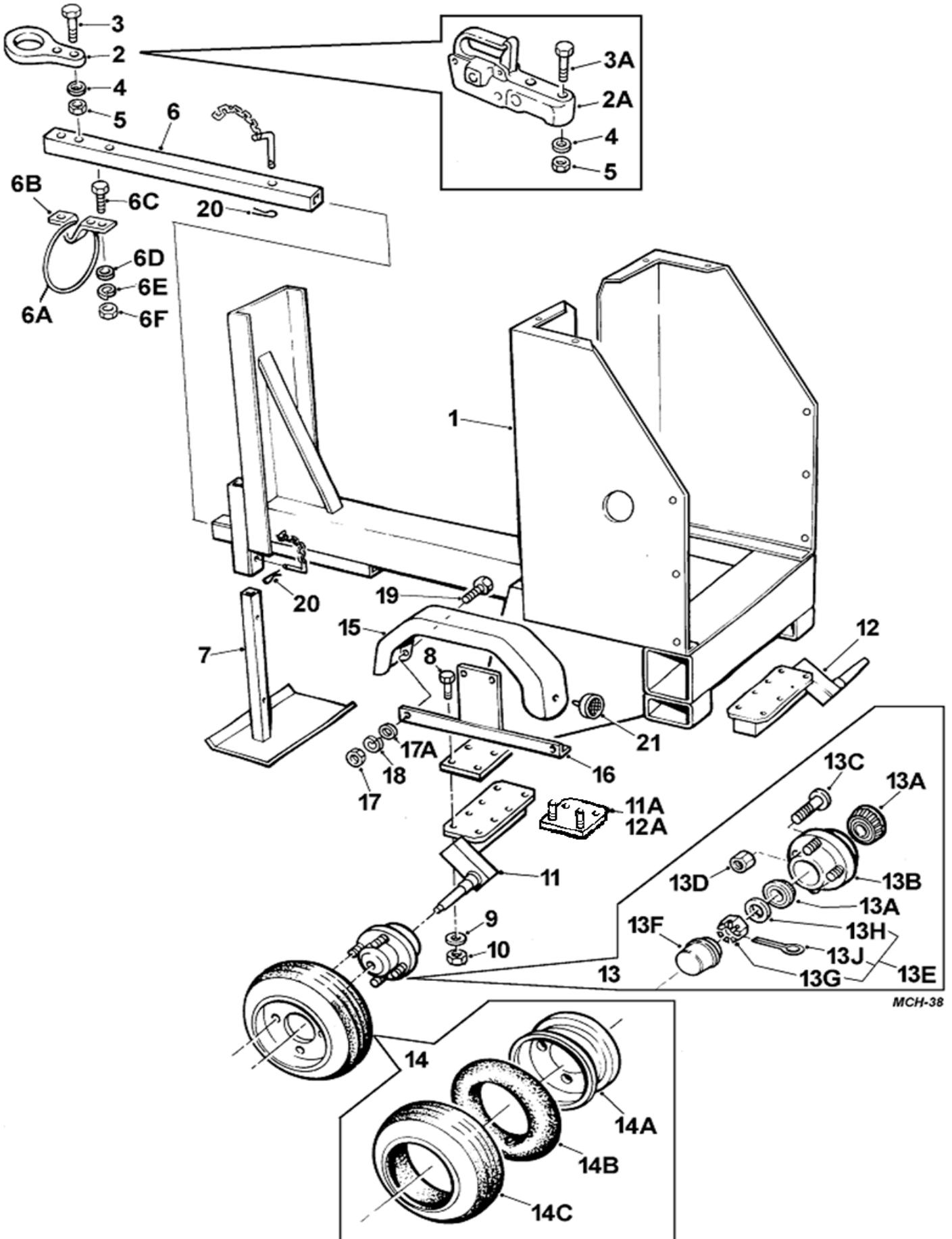

Item	Part no	Serial no	Description	Qty
13H	10S05		WASHER	1
13J	44S03C		PIN, split	1
14	475130700		WHEEL, assembly, 10"	2
14A	V602717		RIM, wheel, 10"	1
14B	475123001		TUBE, inner	1
14C	475123002		TYRE, 10"	1
15	513361000		MUDGUARD, plastic	2
16	513361100		BRACKET, mudguard	2
17	104S03		NUT	8
17A	V2004220		WASHER, "Special"	8
18	41S05		WASHER, spring	8
19	200S03E		SCREW, round head	8
20	902S02		PIN, lynch	2
21	386102000		REFLECTOR, red, non triangular rear of mudguard	2
<b>Following parts are not illustrated</b>				
21A	386103000	05101/	REFLECTOR, white, non triangular front of mudguard	2
21B	11S01A	05101/	SCREW, set, reflector mounting	2
21C	267S03	05101/	WASHER, flat	2
21D	59S13	05101/	NUT, nyloc	2
22	V2006349	05101/	BOARD, lighting	1
22A	513369700	05101/	BUSH, flanged, plastic	4
23	513369600	05101/	PLATE, lighting board mounting	1
23A	8S04F	05101/	BOLT, plate retaining	2
23B	V2004220	05101/	WASHER, special	4
23C	59S03	05101/	NUT, nyloc	2
23D	V2006351	05101/	NUT, winged	2
23E	267S06	05101/	WASHER, flat	2
The mudguard, item no 15, part no 513361000, is normally supplied fitted with a rectangular amber side reflector, should the mudguard not be supplied with the integral reflectors the following parts may be fitted				
24	386104000	05101/	REFLECTOR, amber, non triangular top of mudguard	2
24A	513369300F	05101/	BRACKET, folded, amber reflector	2
24B	11S01A	05101/	SCREW, set	6
24C	267S03	05101/	WASHER, flat	10
24D	59S13	05101/	NUT, nyloc	6
25	513371700	05811/	PLATE, vent, Yanmar L48V5V <i>Not illustrated</i>	2
26	11S02A		SCREW, set	8
27	17S03		WASHER, spring	8

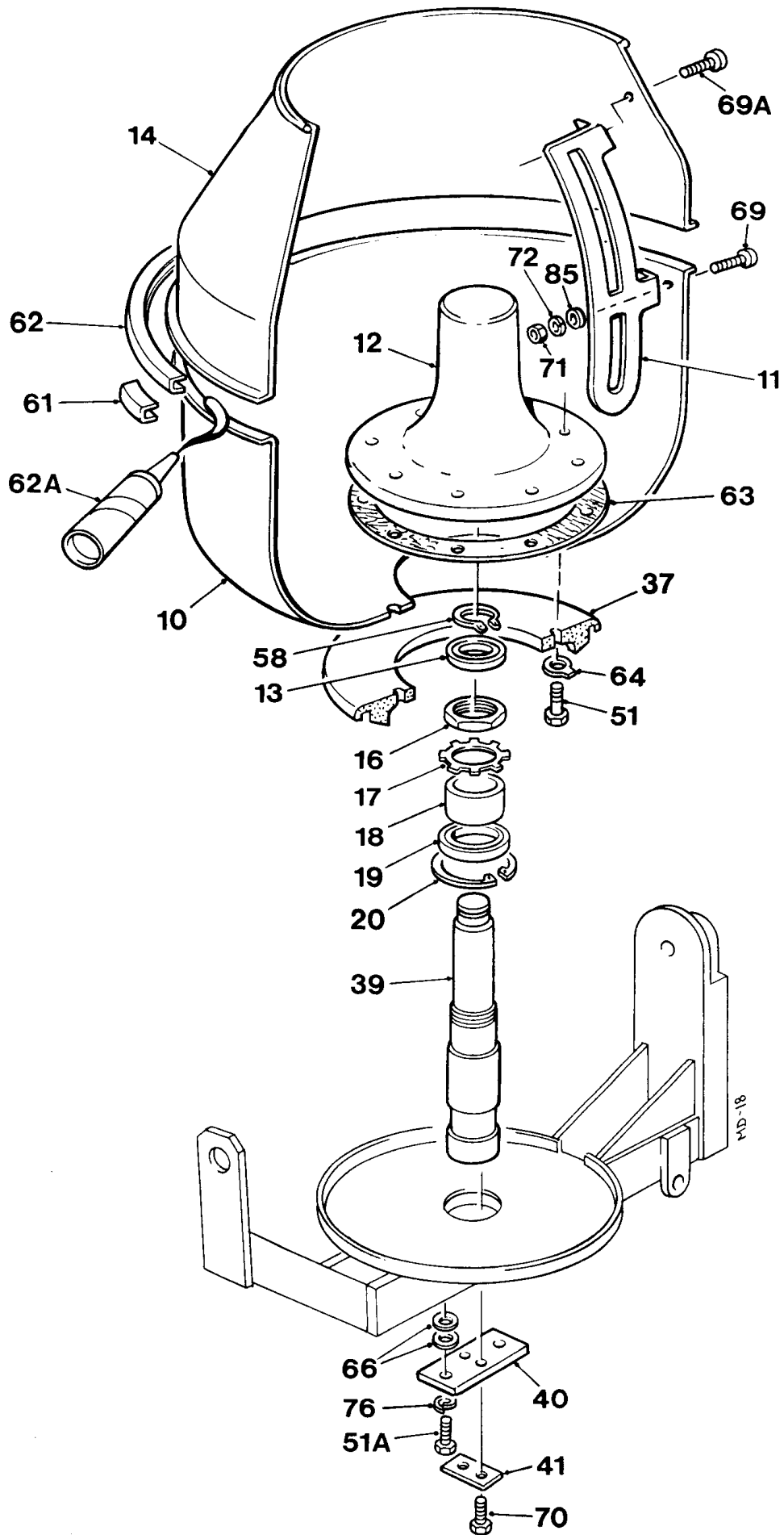

**DRUM**

**B - 1A**

Item	Part no	Serial no	Description	Qty
10	513152901		BASE, drum, <b>100T</b>	1
10	513161001		BASE, drum, <b>150T &amp; 175T</b>	1
11	513151100		BLADE, <b>100T</b> ( <i>Not Honda engines</i> )	2
11	513363100		BLADE, <b>100T</b> ( <i>With Honda engines</i> )	2
11	513157500		BLADE, <b>150T &amp; 175</b>	2
12	513149600		DRUM CENTRE	1
13	88S07D		BEARING	1
14	513152902		CONE, drum, <b>100T</b>	1
14	513161002		CONE, drum, <b>150T</b>	1
14	513203202		CONE, drum, <b>175T</b>	1
16	513208800		NUT, locking	1
17	22096210		WASHER, locking	1
18	513152300		DISTANCE PIECE, drum shaft	1
19	88S20D		BEARING	1
20	132390000		CIRCLIP	1
37	513150100		BEVEL GEAR, drum	1
39	513152200		SHAFT, drum	1
40	513152000		FLANGE, drum shaft	1
41	513152100		WASHER, tab	1
51	66S05D		SCREW	8
51A	28S05G		SCREW	2
58	142330000		CIRCLIP	1
61	513203900		BRIDGE PIECE, <b>100T</b>	1
61	513203800		BRIDGE PIECE, <b>150T &amp; 175T</b>	1
62	513203600		CLIP, drum, <b>100T</b>	1
62	513203100		CLIP, drum, <b>150T &amp; 175T</b>	1
62A	V2000772		SEALANT	tube 1
63	513202800		GASKET	1
64	513199800		WASHER, tab	6
66	10S04		WASHER, flat	AR
69A	200S03E		SCREW, blade upper, <b>100T</b> , obsolete, use	
69A	301S06F		SCREW, blade upper, <b>100T</b> , metric	4
69	200S03G		SCREW, blade lower, <b>100T</b> , obsolete, use	
69	301S06H		SCREW, blade lower, <b>100T</b> , metric	4
69A	200S03G		SCREW, blade upper, <b>150T/175T</b> obsolete, use	
69A	301S06H		SCREW, blade upper <b>150T/175T</b> metric	4
69	200S03H		SCREW, blade lower, <b>150T/175T</b> obsolete, use	
69	301S06J		SCREW, blade lower <b>150T/175T</b> metric	4

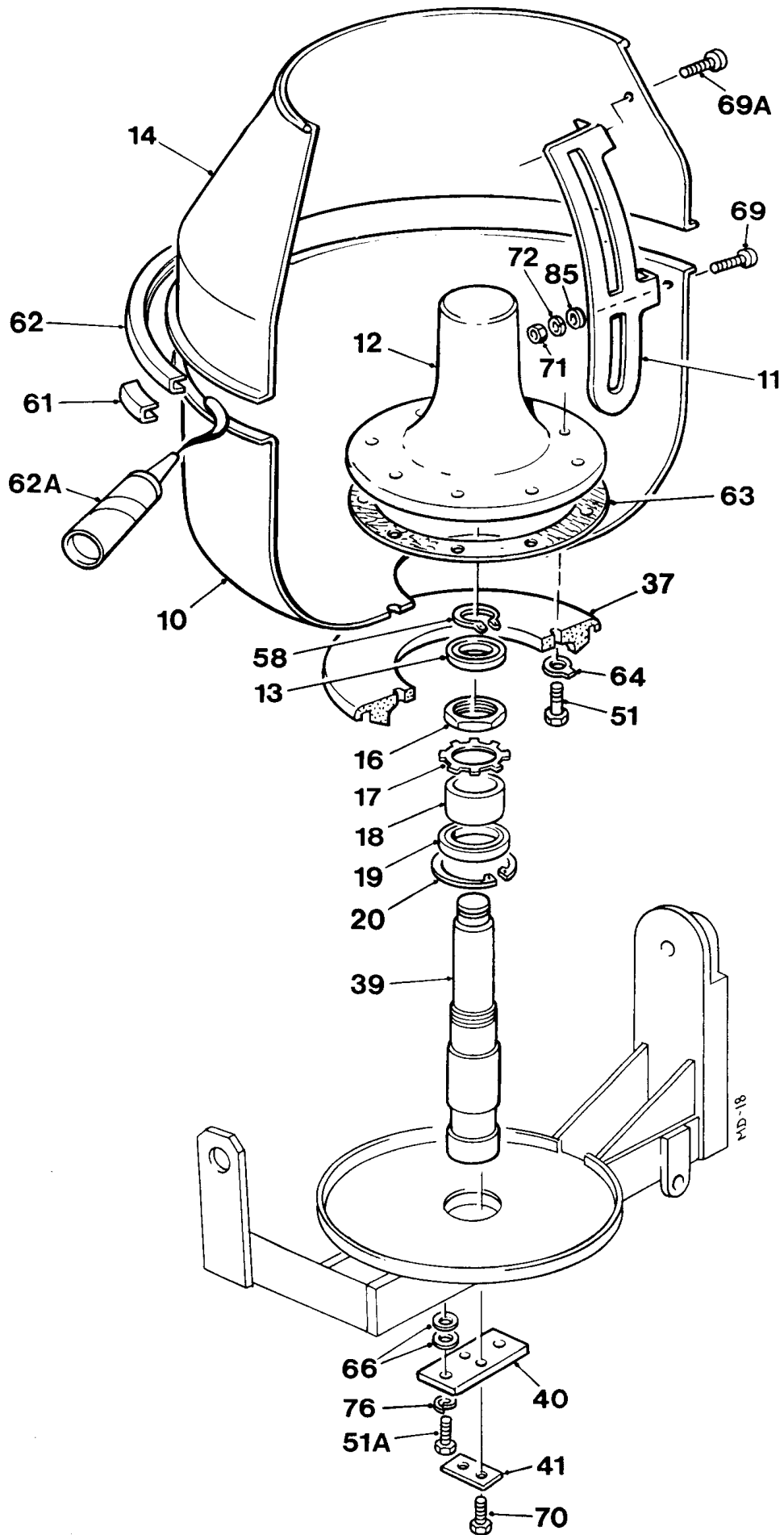

**DRUM****B - 1A**

<b>Item</b>	<b>Part no</b>	<b>Serial no</b>	<b>Description</b>	<b>Qty</b>
70	28S05G		SCREW	2
71	104S03		NUT, imperial, obsolete, use	
71	7S04		NUT, metric	8
72	41S05		WASHER, spring, imperial, obsolete, use	
72	17S05		WASHER, spring, metric	8
76	41S07		WASHER, spring	2
85	10S03		WASHER, flat, imperial, obsolete, use	
85	267S06		WASHER, flat, metric	8



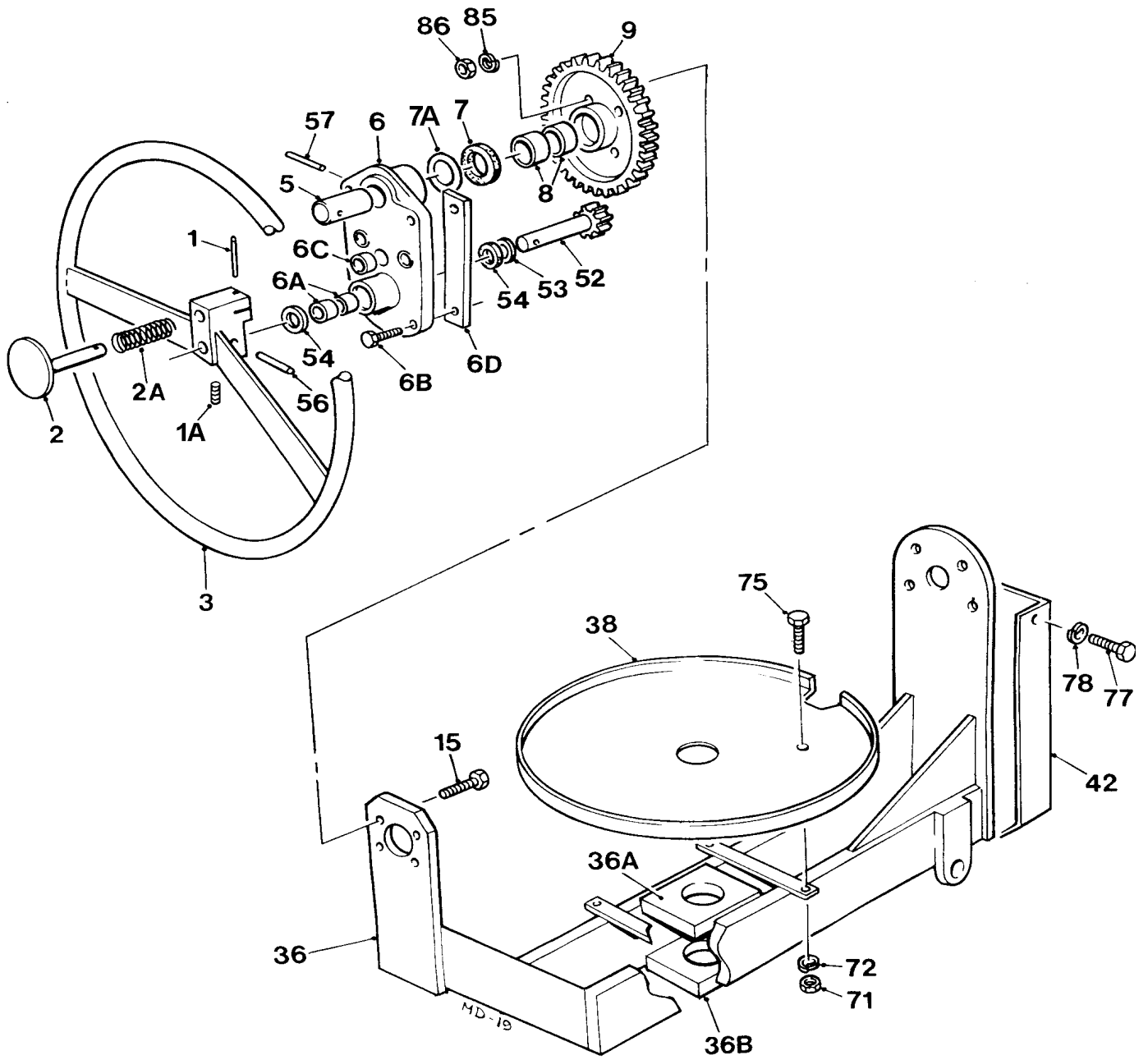

# TRUNNION & TILT WHEEL

# B - 1B

Item	Part no	Serial no	Description	Qty
1	54S01A		PIN, spirol	1
1A	57S06F1	05999 /	SCREW, grub, <b>100T</b>	1
1A	57S06F1	02026 /	SCREW, grub, <b>150T</b>	1
1A	57S06F1	02021 /	SCREW, grub, <b>175T</b>	1
2	513194400		PLUNGER, locking	1
2A	513345300	803866 /	SPRING, plunger, <b>100T</b>	1
2A	513345300	801072 /	SPRING, plunger, <b>150T</b>	1
2A	513345300	801081 /	SPRING, plunger, <b>175T</b>	1
3	513345400		HANDWHEEL	1
5	513151000		STUB, trunnion journal	1
-	513149400		BRACKET, tilting, assembly	1
6	-		BRACKET, tilting (order assembly)	1
6A	112821000		BUSH	2
6B	103S04C		SCREW, socket head cap	4
6C	114625320		BUSH	3
6D	513212300		RETAINING BAR, tilting bracket	2
7	225520280		FELT SEAL	1
7A	10S09		WASHER, flat	AR
8	112820000		BUSH	2
9	513149300		GEAR, tilting	1
15	6S03E		BOLT	4
36	513211400		TRUNNION, <b>100T</b>	1
36	513211500		TRUNNION, <b>150T &amp; 175T</b>	1
36A	513212000		PLATE, upper (welded)	1
36B	513212000		PLATE, lower (welded)	1
38	513153000		GUARD, bevel gear	1
42	513152700		GUARD, chain, <b>100T</b>	1
42	513203300		GUARD, chain, <b>150T &amp; 175T</b>	1
52	513345600		PINION, tilting	1
53	10S18		WASHER, flat	1
54	225514220		WASHER, felt	2
56	513374900		PIN, grooved	1
57	55S07Q		PIN, spirol	1
71	104S03		NUT	4
72	41S05		WASHER, spring	4
75	66S03CC		SCREW, set	4
77	66S02CC		SCREW, set	2
78	41S04		WASHER, spring	2
85	10S03		WASHER, flat	4
86	107S14		NUT, 'Nyloc' self-locking	4

**B - 1C**

**100T, 150T & 175T Mixers from February 1988**

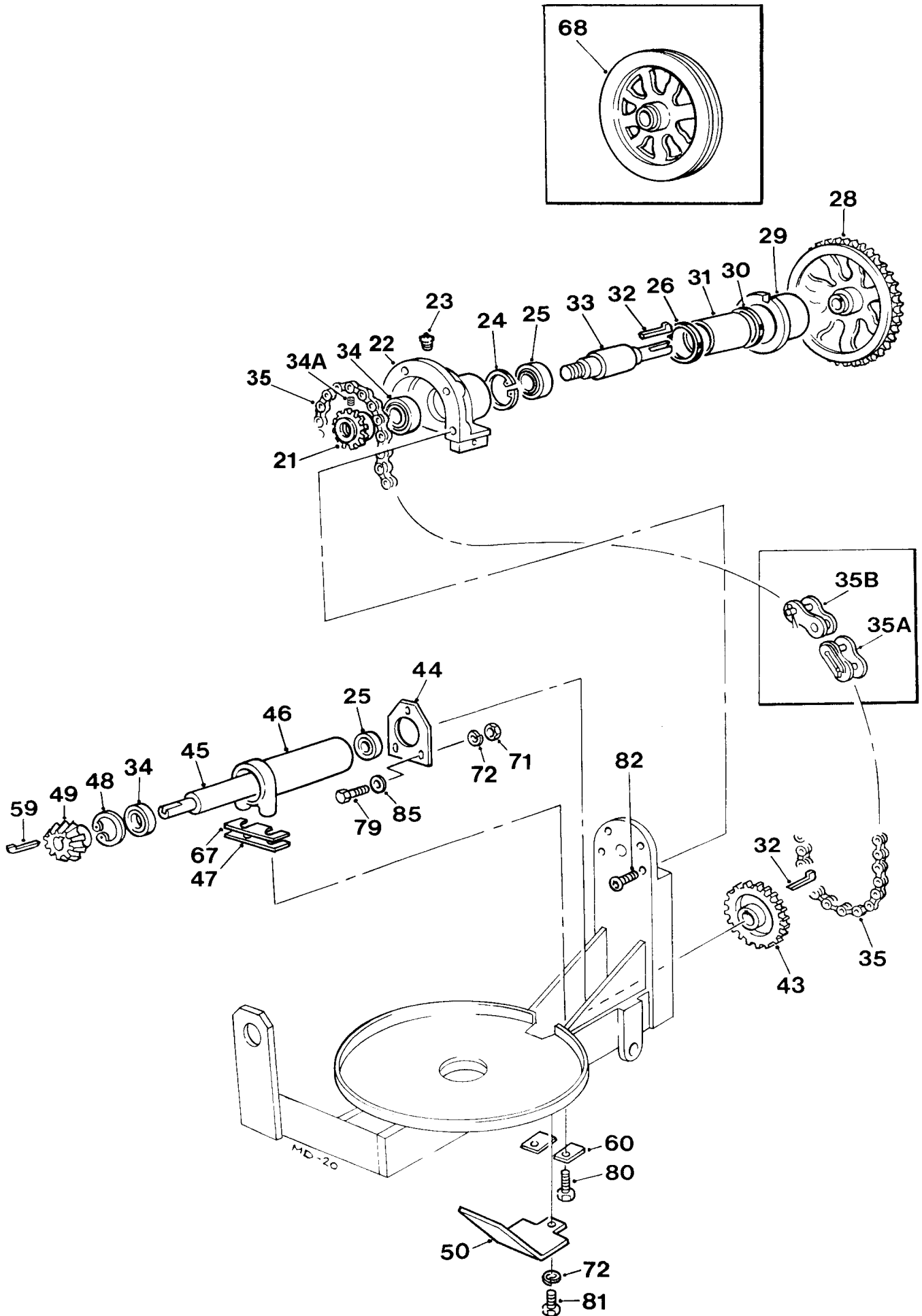

# DRUM DRIVE

# B - 1C

Item	Part no	Serial no	Description	Qty
21	513151600		SPROCKET, countershaft, L.H. thread (Not Honda engines)	1
21	513363200		SPROCKET, countershaft, R.H. thread (With Honda engines)	1
22	513149700		JOURNAL, trunnion	1
23	315803100		PLUG, lubricating	1
24	132352000		CIRCLIP	1
25	88S15D		BEARING	2
26	225104410	/ Jan-97	FELT STRIP, ' <b>Obsolete</b> ' use 'O' ring	2
26	49S41	Jan-97 /	O' RING, 79mm I/D	1
28	513150200		CHAINWHEEL, countershaft	1
29	513150400		BEARING, trunnion	1
30	225104410	/ Jan-97	FELT STRIP, ' <b>Obsolete</b> ' use 'O' ring	1
30	49S42	Jan-97 /	O' RING, 75.5mm I/D	1
31	513153100		BEARING	1
32	300204140		KEY, gib head	2
33	513151700		COUNTERSHAFT, L.H. thread (Not Honda engines)	1
33	513363300		COUNTERSHAFT, R.H. thread (With Honda engines)	1
34	88S05D		BEARING	2
34A	57S04D2	06707 /	SCREW, grub, <b>100T</b>	1
34A	57S04D2	02678 /	SCREW, grub, <b>150T &amp; 175T</b>	1
35	134105056		CHAIN, <b>100T</b>	1
35	134105060		CHAIN, <b>150T &amp; 175T</b>	1
35A	134105002		LINK, connecting	1
35B	134105001		LINK, half	AR
43	513150300		SPROCKET, bevel pinion shaft	1
44	513298900		PLATE, adjusting	1
45	513152500		SHAFT, bevel pinion, <b>100T</b>	1
45	513158700		SHAFT, bevel pinion, <b>150T &amp; 175T</b>	1
46	513149800		HOUSING, pinion shaft, <b>100T</b>	1
46	513160700		HOUSING, pinion shaft, <b>150T &amp; 175T</b>	1
47	513152400		PACKING PIECE (set of 4)	sets 2
48	132362000		CIRCLIP	1
49	513278400		BEVEL PINION	1
50	513211800		GUARD, bevel pinion	1

B - 1C

100T, 150T & 175T Mixers from February 1988

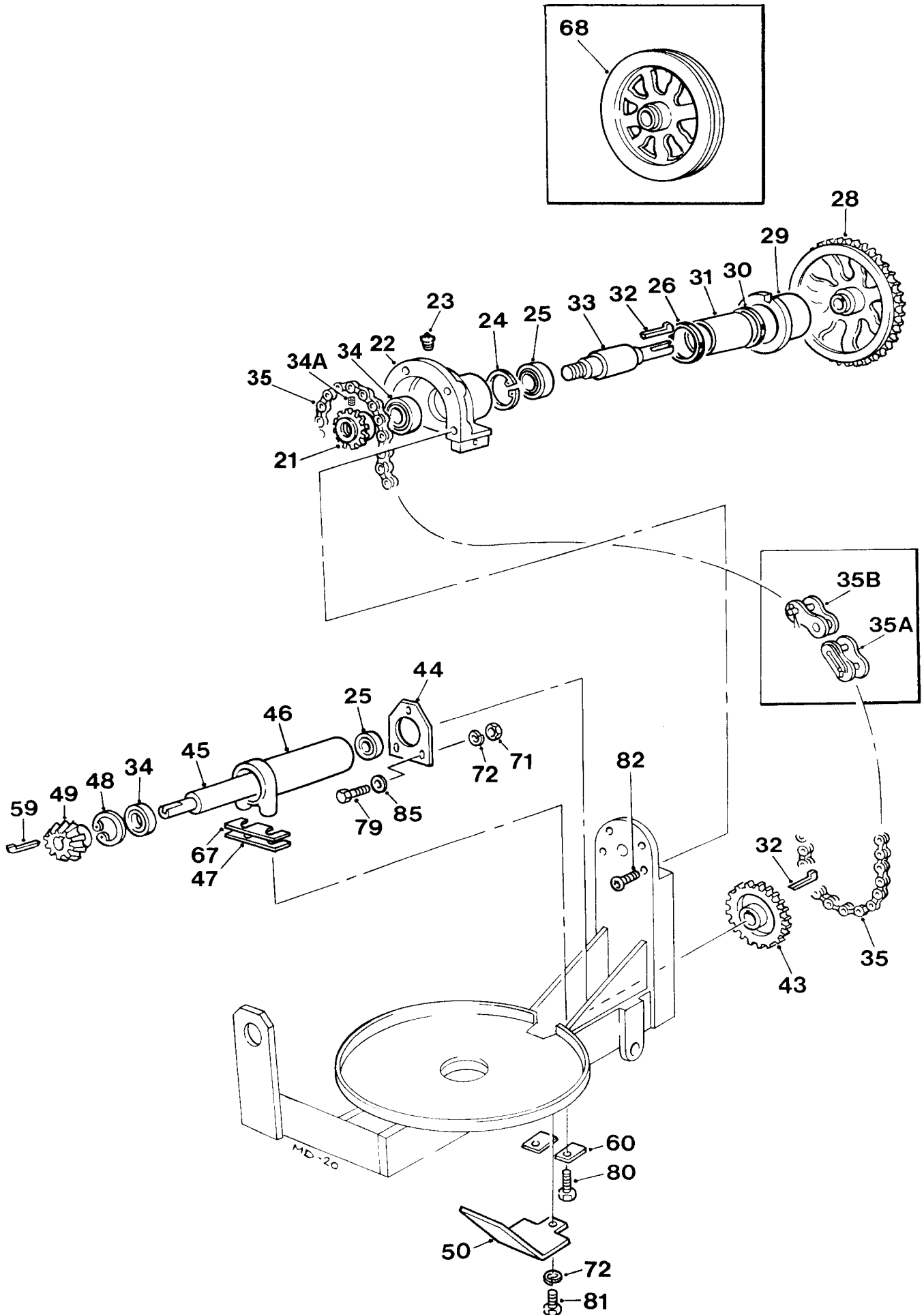

**DRUM DRIVE****B - 1C**

<b>Item</b>	<b>Part no</b>	<b>Serial no</b>	<b>Description</b>	<b>Qty</b>
59	300204140		KEY, gib head	1
60	513211900		WASHER, tab	2
67	513211700		PACKER	1
68	513290700		PULLEY, 'V', for electric motors, Yanmar and Honda engines	1
71	104S03		NUT	
72	41S05		WASHER, spring	4
79	66S03C		SCREW	3
80	66S03D		SCREW	2
81	66S03AA		SCREW	1
82	208S03F		SCREW, c/sunk socket	4
85	10S03		WASHER, flat	3

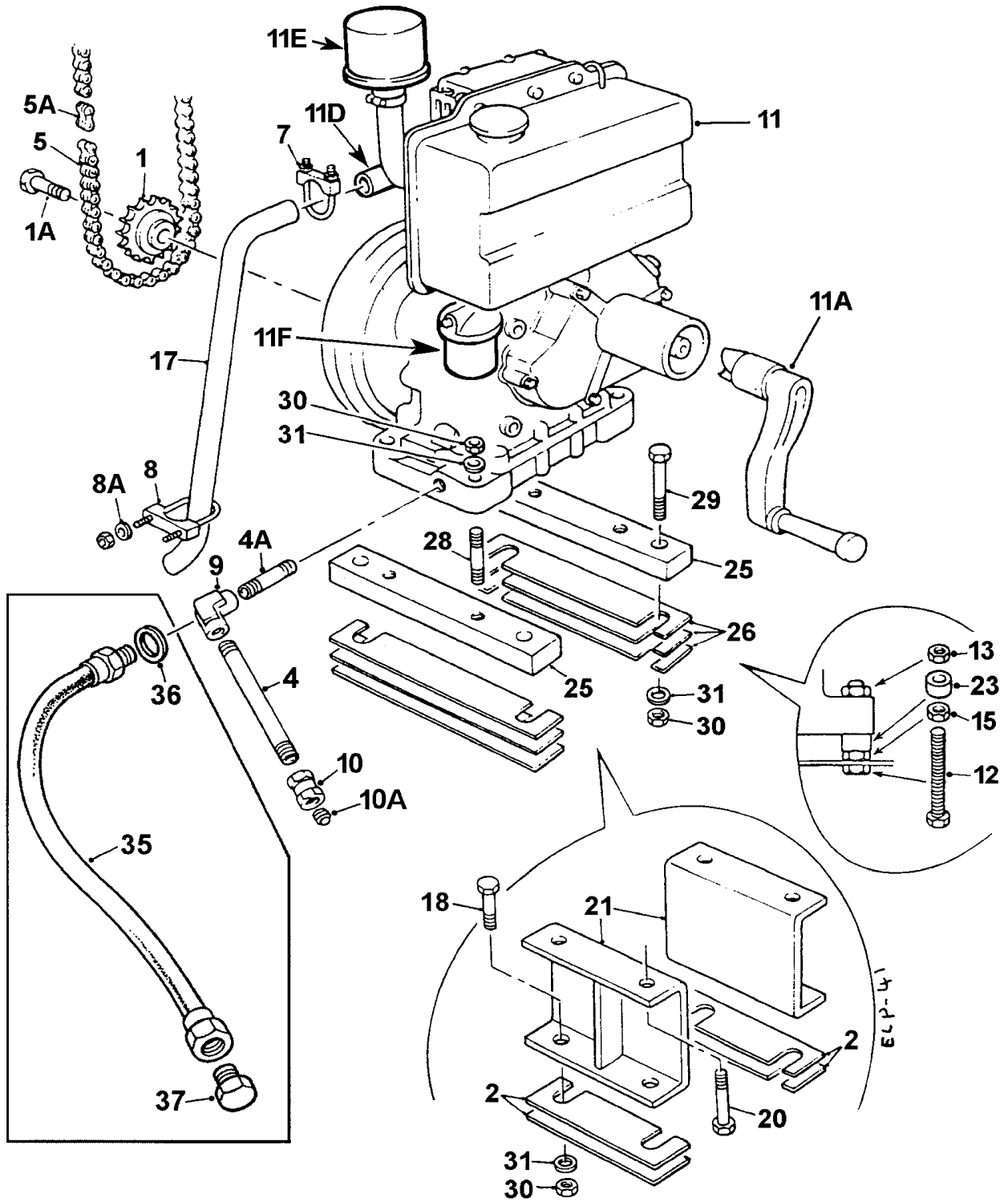
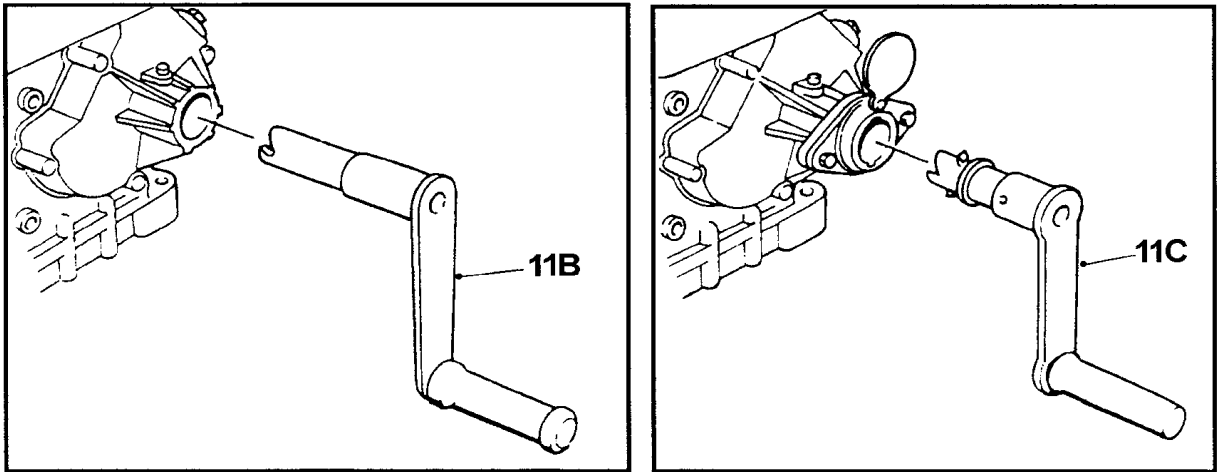

Item	Part no	Serial no	Description	Qty
1	513344100		SPROCKET, engine, assembly	1
1A	EL60222040		SCREW, retaining	1
2	513127500		KIT, shims, <b>150T</b>	pack 1
—	513127501		SHIM, 3mm, <b>150T</b>	6
—	513127502		SHIM, 1.5mm, <b>150T</b>	4
—	—	Jan-95 /	SHIM, 0.7mm, <b>150T</b>	2
4	513278200	(year) / 1995/96	PIPE, 125mm long, 1/4" BSP	1
4	513359800	1995/96 / 2003	PIPE, 125mm long, 1/2" BSP	1
4A	513256500	(year) / 1995/96	PIPE, 60mm long, 1/4" BSP	1
4A	513359700	1995/96 / 2003	PIPE, 60mm long, 1/2" BSP	1
5	134105095		CHAIN, roller	1
5A	134105002		LINK, connecting	1
—	134105001		LINK, half ( <i>not illustrated</i> )	1
7	153S01		CLAMP, pipe	1
8	153S01		CLAMP, pipe	1
8A	267S04		WASHER, flat	4
9	241102000	(year) / 1995/96	ELBOW, female, 1/4" BSP	1
9	241104000	1995/96 / 2003	ELBOW, female, 1/2" BSP	1
10	241902000	(year) / 1995/96	FITTING, straight female, 1/4" BSP	1
10	241904000	1995/96 / 2003	FITTING, straight female, 1/2" BSP	1
10A	241702000	(year) / 1995/96	PLUG, oil drain, 1/4" BSP tapered	1
10A	241704000	1995/96 / 2003	PLUG, oil drain, 1/2" BSP tapered	1
11	354052000		ENGINE, Lister-Petter LT1/LV1-32 "Export" ("UK/EEC" upto 1995)	1
11A	EL60150016	/ Jan-95	# STARTING HANDLE	1
11B	EL60252971	Jan-95 /	# STARTING HANDLE, without anti kickback	1
11	354054200	Jan-95 /	ENGINE, Lister-Petter LT1/LV1-32 "UK/EEC"	1
11C	EL375231	Jan-95 /	# STARTING HANDLE, with anti kickback	1

# When ordering starting handles,  
specify the type required

**NOTE : ENGINE CHANGE Lister-Petter LT1-32 to LV1-32**

From mixer serial numbers: 100T 07978 and 150T 03813.

Early in 2005 the Lister-Petter LT1-32 was superseded by the LV1-32. The engines as complete assemblies are interchangeable as are consumable items such as filters etc. Major items such as fuel injection pump, cylinder and piston, crankshaft, and conrod are different and when ordering spares it is important to quote the engine type.



**C - 1** 100T & 150T Mixer *from February 1988*

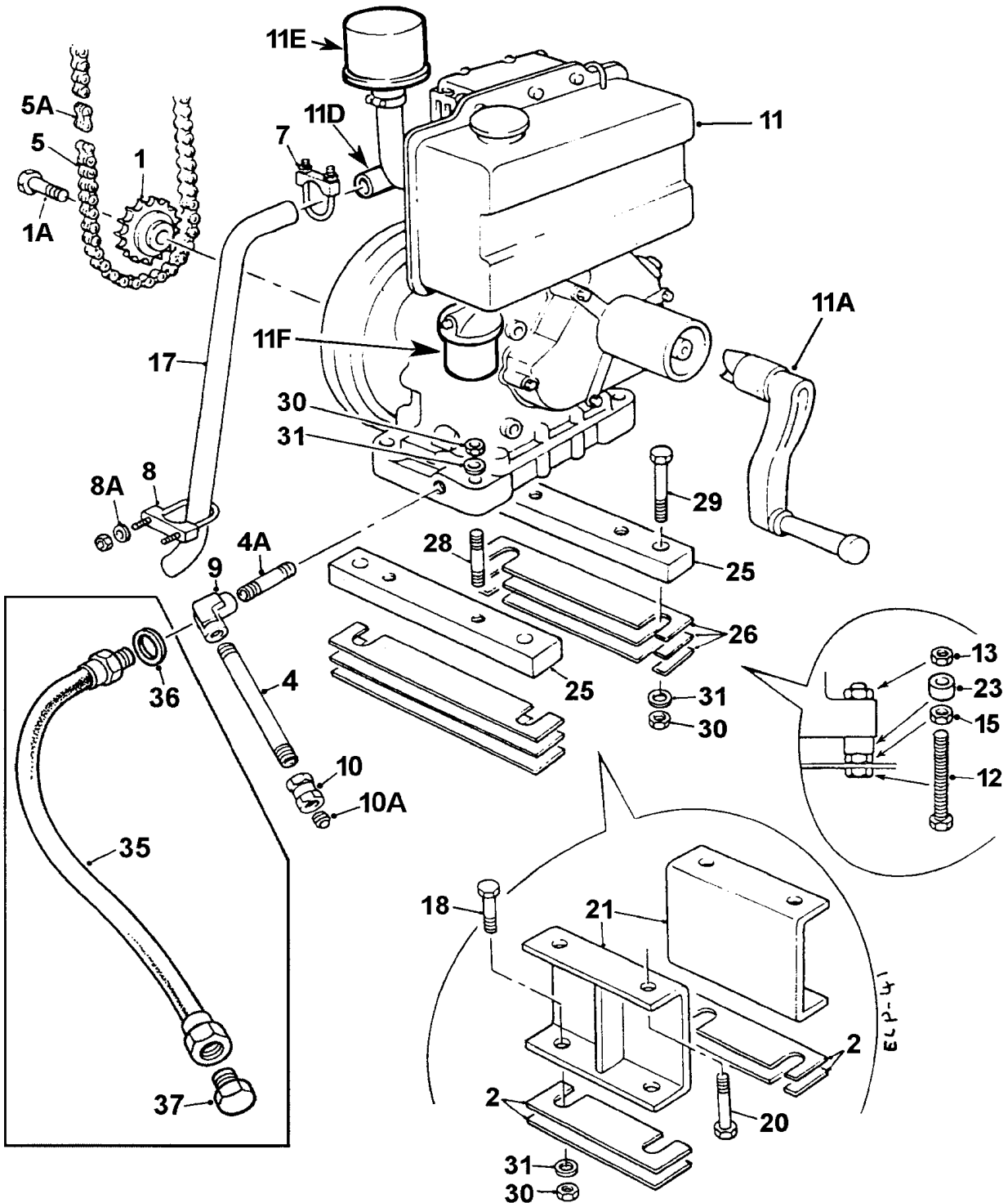
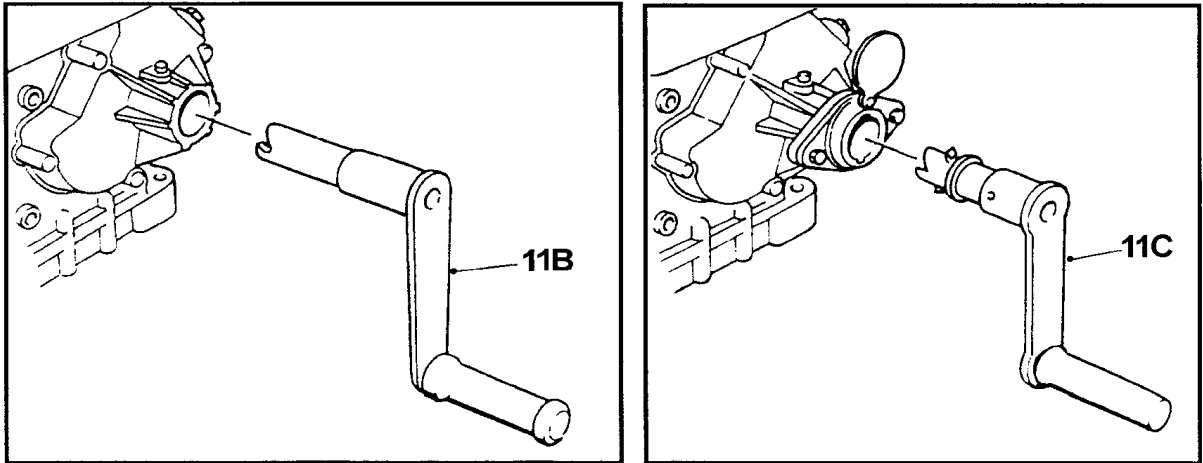

<b>Item</b>	<b>Part no</b>	<b>Serial no</b>	<b>Description</b>	<b>Qty</b>
<b>Continued &gt;&gt;</b>				
11D	EL60142480		MANIFOLD, engine exhaust (part of engine)	1
11E	EL60142520		FILTER, air	1
11F	EL20113118		FILTER, fuel	1
12	11S05T	/ 1995/96	SCREW, set, <b>100T</b>	4
13	61S05	/ 1995/96	NUT, binx "Binx", self-locking, <b>100T</b>	4
15	7S05	/ 1995/96	NUT, <b>100T</b>	4
17	513341900		PIPE, exhaust, <b>100T</b>	1
17	513342500		PIPE, exhaust, <b>150T</b>	1
18	8S05F		BOLT, <b>150T</b>	4
20	8S05H		BOLT, <b>150T</b>	4
21	513343000		CHANNEL, engine base, <b>150T</b>	2
23	513340500	(year) / 1995/96	SPACER, <b>100T</b>	
25	513266700	1995/96 /	BASE BLOCK, engine, <b>100T</b>	4
26	513248400	1995/96 /	KIT,shims, <b>100T</b>	pack 1
—	513248401	1995/96 /	SHIM, 10G. <b>100T</b>	6
—	513248402	1995/96 /	SHIM, 16G. <b>100T</b>	4
—	513248403	1995/96 /	SHIM, 14G. <b>100T</b>	2
—	513248404	1995/96 /	SHIM, 18G. <b>100T</b>	2
—	—	Dec-96 /	SHIM, 22G. <b>100T</b>	2
28	V601339	1995/96 /	STUD, <b>100T</b>	4
29	8S05H	1995/96 /	BOLT, <b>100T</b>	4
30	61S05		NUT, "Binx", self-locking	8
31	267S07		WASHER, flat	8
35	513362800	2003 / (year)	HOSE, sump oil drain	1
36	100S04	2003 /	SEAL, bonded	1
37	127S04	2003 /	PLUG, blanking	1

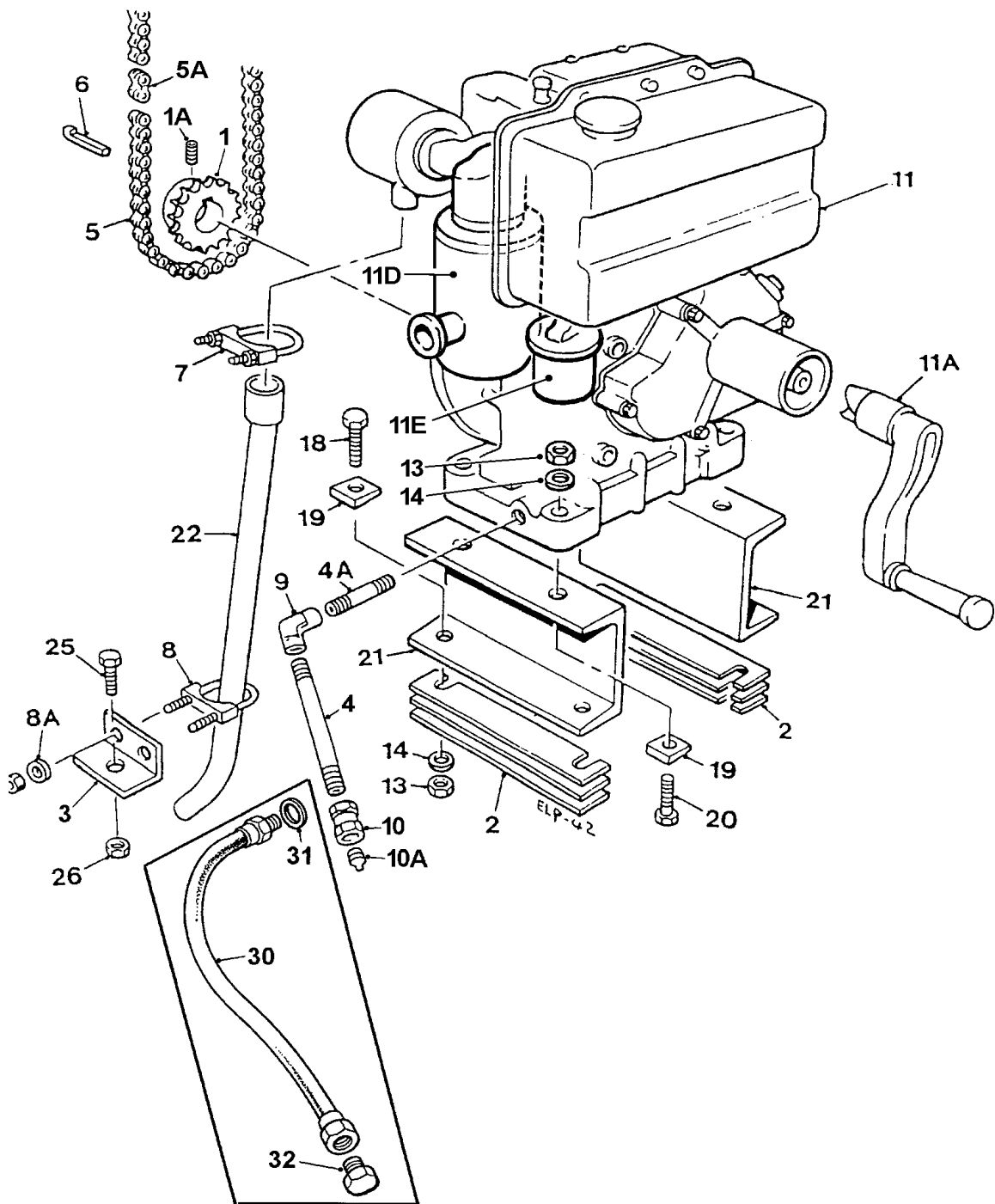
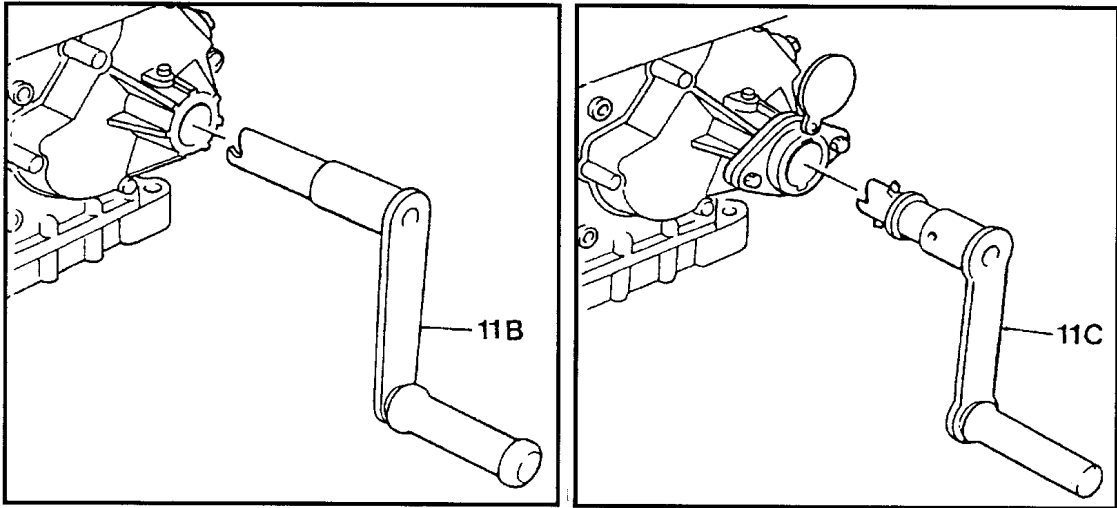

Item	Part no	Serial no	Description	Qty
1	513248300		SPROCKET, engine	1
1A	57S05D2	02679 /	SCREW, grub	1
2	513248400		SHIMS	pack 1
3	513266800		BRACKET, exhaust	1
4	513278200	(year) / 1995/96	PIPE, 125mm long, 1/4" BSP	1
4	513359800	1995/96 / 2003	PIPE, 125mm long, 1/2" BSP	1
4A	513256500	(year) / 1995/96	PIPE, 60mm long, 1/4" BSP	1
4A	513359700	1995/96 / 2003	PIPE, 60mm long, 1/2" BSP	1
5	134105095		CHAIN, roller	1
5A	134105002		LINK	1
—	134105001		LINK, half ( <i>not illustrated</i> )	1
6	300204160		KEY, gib head	1
7	354051005		CLAMP, exhaust	1
8	153S01		CLAMP, exhaust	1
8A	267S04		WASHER, flat	2
9	241102000	(year) / 1995/96	ELBOW, female, 1/4" BSP	1
9	241104000	1995/96 / 2003	ELBOW, female, 1/2" BSP	1
10	241902000	(year) / 1995/96	FITTING, straight female, 1/4" BSP	1
10	241904000	1995/96 /	FITTING, straight female, 1/2" BSP	1
10A	241702000	(year) / 1995/96	PLUG, oil drain, 1/4" BSP tapered	1
10A	241704000	1995/96 / 2003	PLUG, oil drain, 1/2" BSP tapered	1
11	354051000		ENGINE, Lister-Petter LT1/LV1-10 "Export" (“UK/EEC” up to 1995)	1
11A	EL60150016	/ Jan-95	# STARTING HANDLE	1
11B	EL60252971	Jan-95 /	# STARTING HANDLE, without anti kickback	1
11	354054100	Jan-95 /	ENGINE, Lister-Petter LT1/LV1-10 "UK/EEC"	
11C	EL375231	Jan-95 /	# STARTING HANDLE, with anti kickback # When ordering starting handles specify the type required.	1
11D	EL60131350		FILTER, air	1
11E	EL20113118		FILTER, fuel	1

**NOTE : ENGINE CHANGE Lister-Petter LT1-10 to LV1-10**

Late in 2003 the Lister-Petter LT1-10 was superseded by the LV1-10. The engines as complete assemblies are interchangeable as are consumable items such as filters etc. Major items such as fuel injection pump, cylinder and piston, crankshaft, and conrod are different and when ordering spares it is important to quote the engine type.

# C - 1A

# 175T Mixer from February 1988

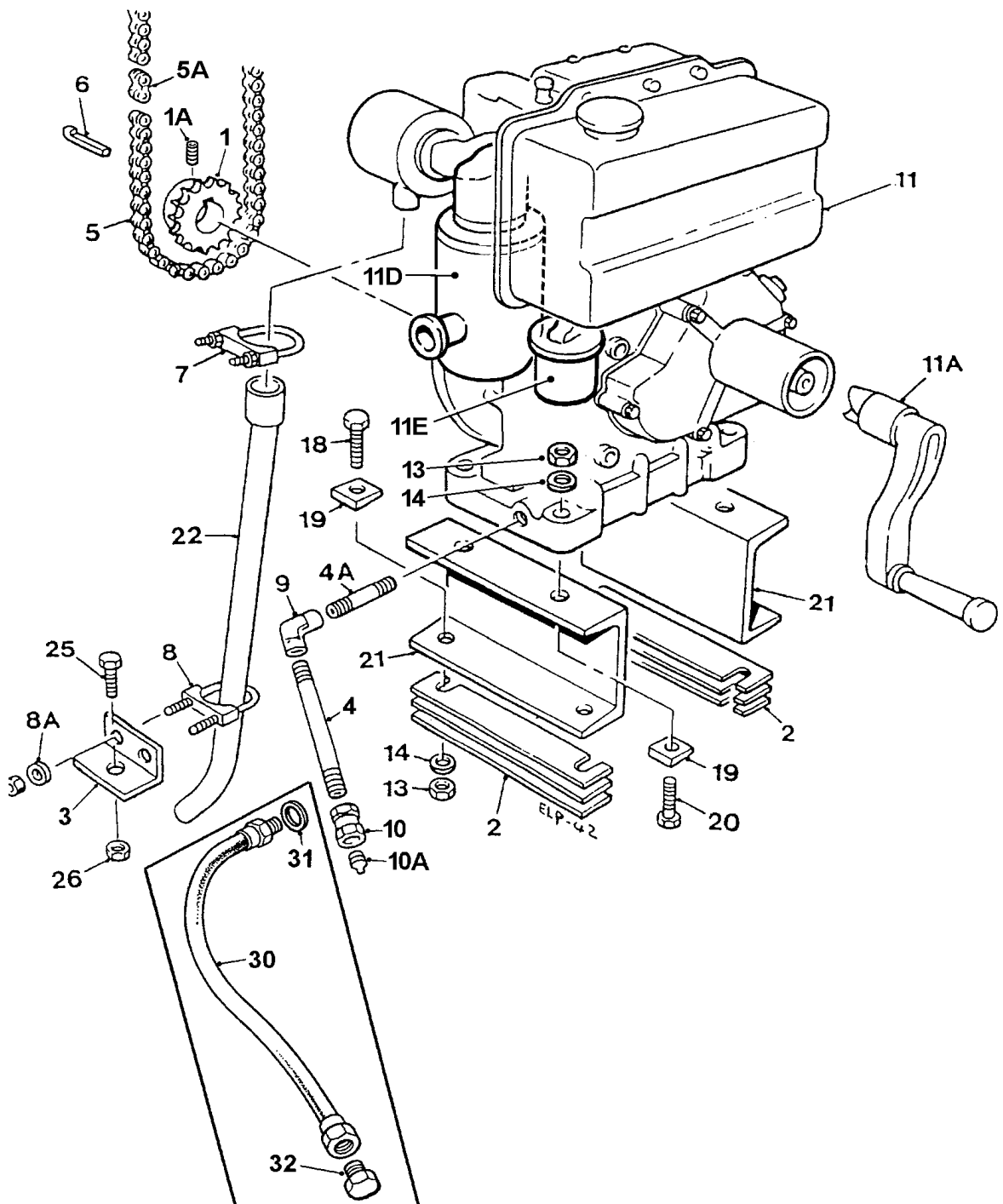
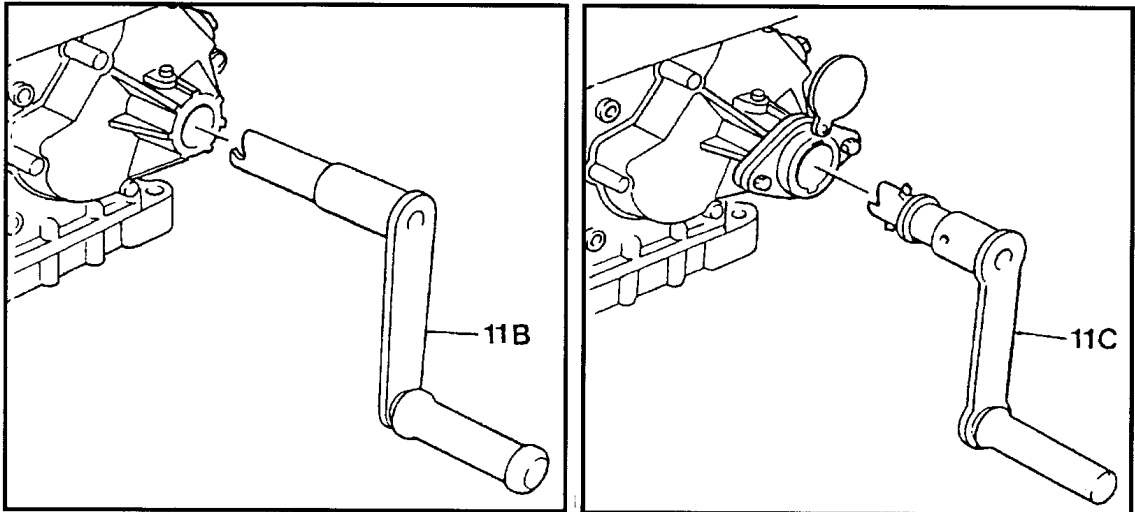

<b>Item</b>	<b>Part no</b>	<b>Serial no</b>	<b>Description</b>	<b>Qty</b>
13	61S05		NUT, "Binx", self-locking	8
14	267S07		WASHER, flat	8
18	8S05E		BOLT	4
19	105S05		WASHER, taper	8
20	8S05J		BOLT	4
21	513267400		CHANNEL, engine base,	2
22	513267500		PIPE, exhaust	1
25	66S05A		SCREW, set	1
26	192S05		NUT, "Binx", self-locking	1
30	513362800	2003 / (year)	HOSE, sump oil drain	1
31	100S04	2003 /	SEAL, bonded	1
32	127S04	2003 /	PLUG, blanking	1

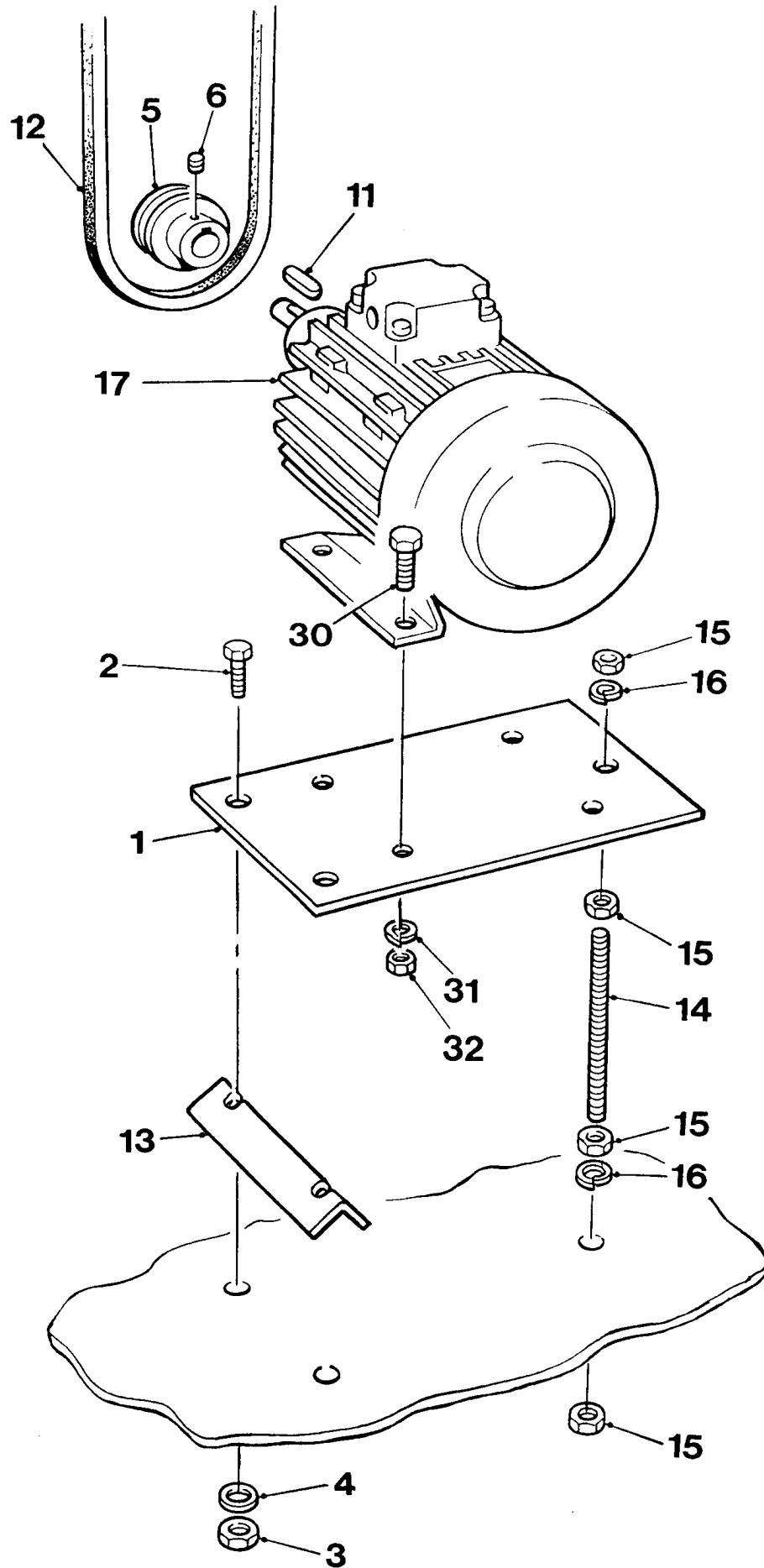

**ELECTRIC (240/110 volt) drive assembly, upto 2005****C - 2A**

<b>Item</b>	<b>Part no</b>	<b>Serial no</b>	<b>Description</b>	<b>Qty</b>
1	513342100		PLATE, motor mounting	1
2	8S05H		BOLT	2
3	61S05		NUT, "Binx"	2
4	267S07		WASHER, flat	2
5	513290600		PULLEY, 'V'	1
6	57S04D2		SCREW, grub	1
11	304710840		KEY, parallel	1
12	397400300		BELT, 'V'	1
13	513342000		ANGLE, motor adjusting	1
14	513333100		STUD	1
15	7S05		NUT	4
16	17S06		WASHER, spring	2
17	202493500		MOTOR, electric, 240v, .75kW (1hp)	1
17	202493600		MOTOR, electric, 110v, 1.1kW (1.5hp)	1
30	66S03A		SCREW, set	4
31	41S05		WASHER, spring	4
32	104S03		NUT	4



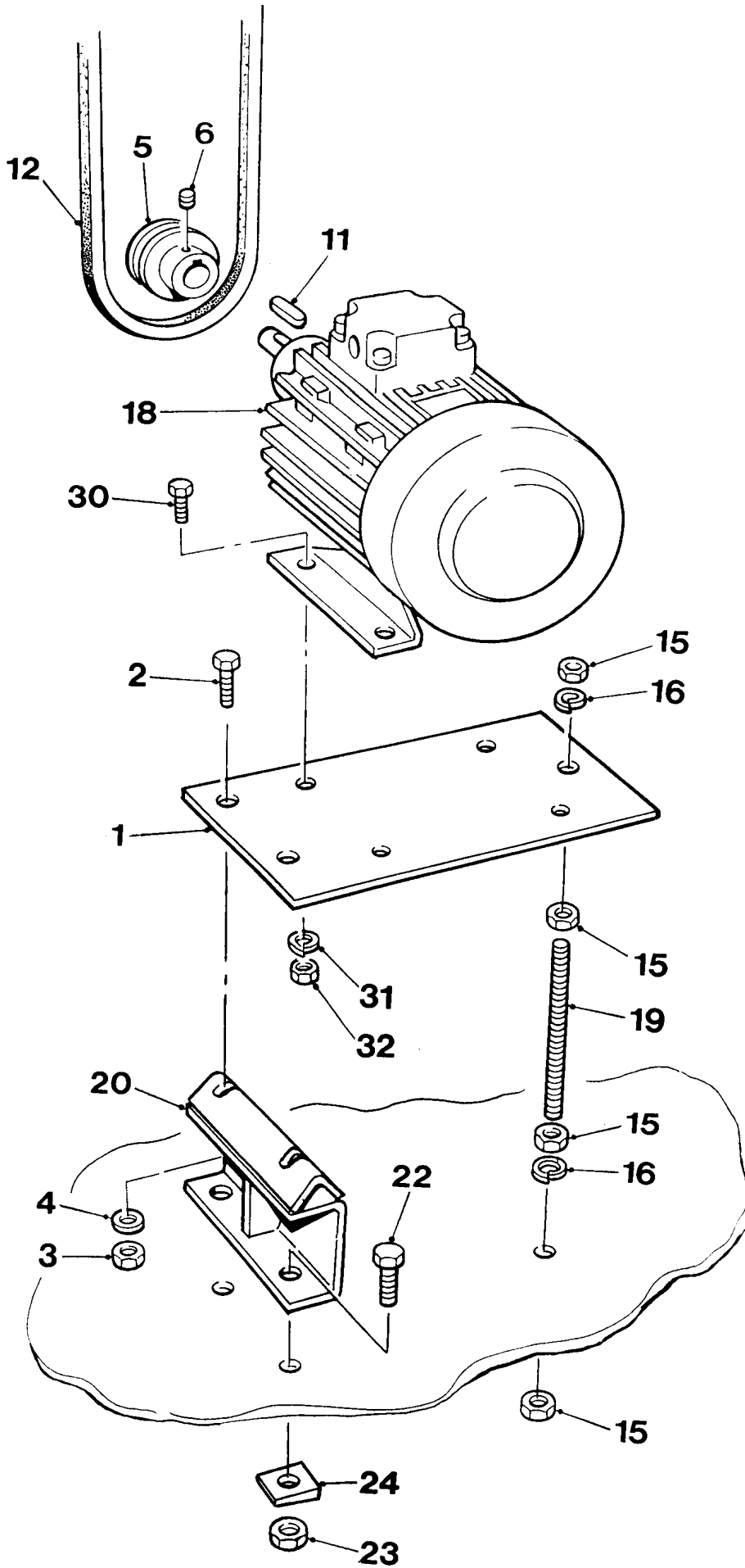

**ELECTRIC (240/110 volt) drive assembly, upto 2005****C - 2B**

Item	Part no	Serial no	Description	Qty
1	513342100	/ Feb-90	PLATE, motor mounting	1
1	513350000	Feb-90 /	PLATE, motor mounting	1
2	8S05H		BOLT	2
3	61S05		NUT, self-locking "Binx"	2
4	267S07		WASHER, flat	2
5	513290600		PULLEY, 'V'	1
6	57S04D2		SCREW, grub	1
11	304710840		KEY, parallel	1
12	397400300		BELT, 'V'	1
13	—			
15	7S05		NUT	4
16	17S06		WASHER, spring	2
18	202493700		MOTOR, electric, 240v, 1.1kW (1.5hp)	1
18	202493800		MOTOR, electric, 110v, 1.1kW (1.5hp)	1
19	513333100		STUD	1
20	513343400		CHANNEL, motor mounting,	1
22	8S05D		BOLT	2
23	61S05		NUT, self-locking, "Binx"	2
24	105S05		WASHER, taper	2
30	66S03A		SCREW, set	4
31	41S05		WASHER, spring	4
32	104S03		NUT	4

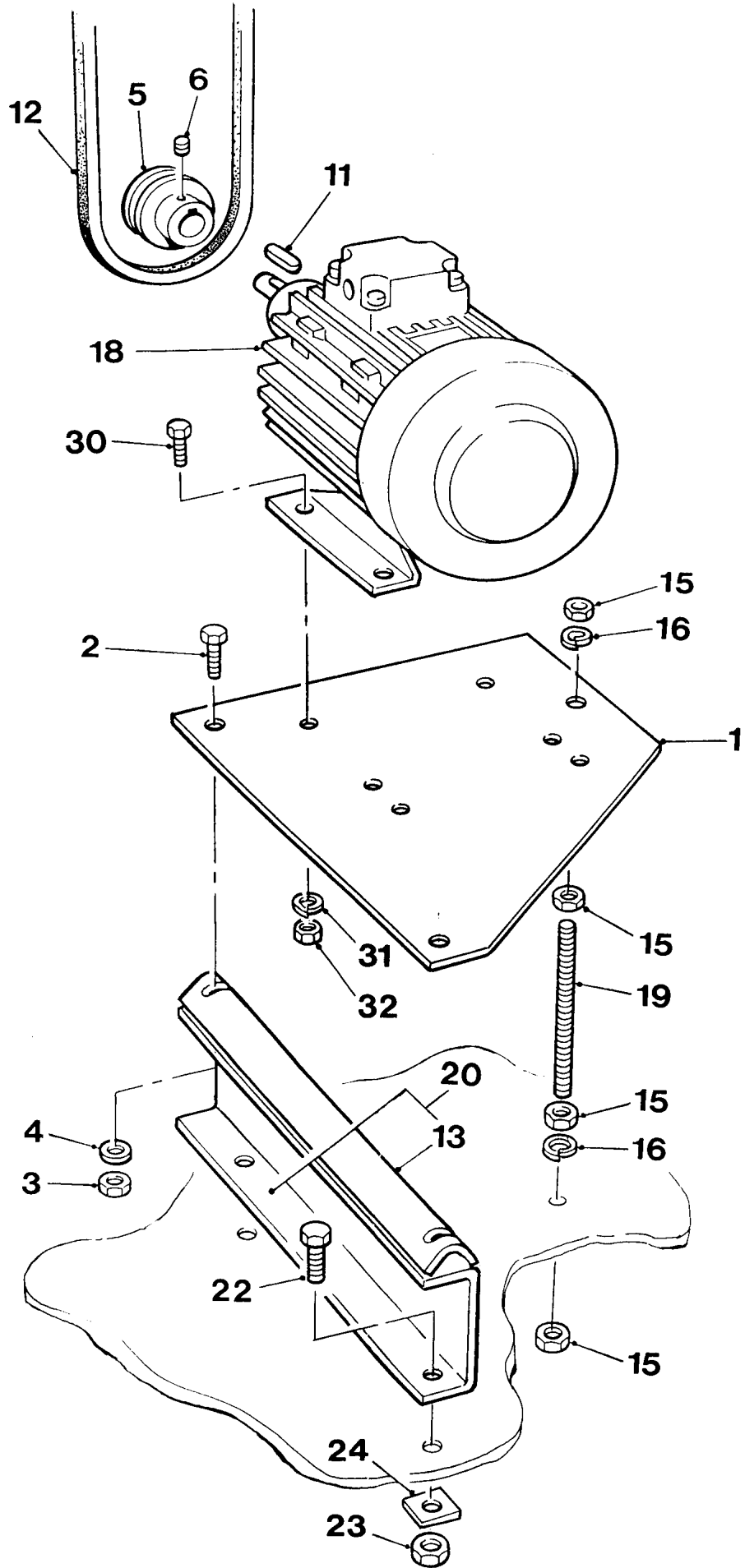

**ELECTRIC (240/110 volt) drive assembly, upto 2005****C - 2C**

<b>Item</b>	<b>Part no</b>	<b>Serial no</b>	<b>Description</b>	<b>Qty</b>
1	513290400		PLATE, motor mounting	1
2	8S05H		BOLT	2
3	61S05		NUT, self-locking "Binx"	2
4	267S07		WASHER, flat	2
5	513290600		PULLEY, 'V'	1
6	57S04D2		SCREW, socket head	1
11	304710840		KEY, parallel	1
12	397400300		BELT, 'V'	1
13	513290300		ANGLE, ( <i>Welded part of item 20</i> )	1
15	7S05		NUT	4
16	17S06		WASHER, spring	2
18	202493700		MOTOR, electric, 240v, 1.1kw (1.5hp)	1
18	202493800		MOTOR, electric, 110v, 1.1kw (1.5hp)	1
19	513333100		STUD	1
20	513290500		CHANNEL, motor mount, ( <i>Includes item 13</i> )	1
22	8S05D		BOLT	2
23	61S05		NUT, self-locking, "Binx"	4
24	105S05		WASHER, taper	2
30	66S03A		SCREW, set	4
31	41S05		WASHER, spring	4
32	104S03		NUT	4

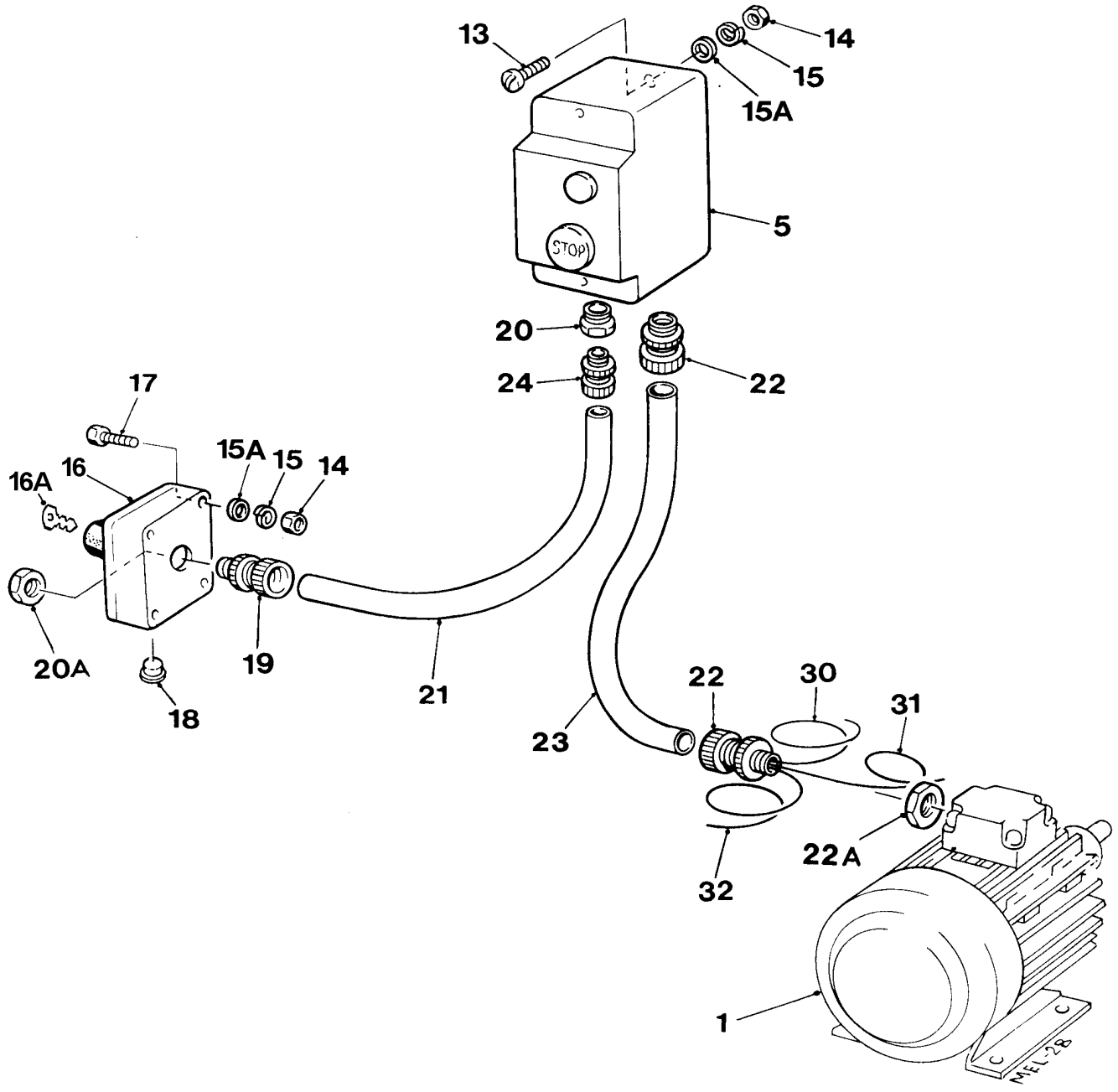

**START SWITCHES, electric drive, upto 2005**

**C - 3**

Item	Part no	Date	Description	Qty
1	.....		ELECTRIC MOTOR (see Index page)	1
5	208398600		STARTER, Danfoss 240v, <b>100T, 150T &amp; 175T</b>	1
.....	208398500		CASE, starter	1
.....	192928000		CONTACTOR	1
.....	207818001		RELAY, overload	1
5	208398800		STARTER, Danfoss 110v, <b>100T</b>	1
.....	208398500		CASE, starter	1
.....	192928000		CONTACTOR	1
.....	207818003		RELAY, overload	1
5	208398900		STARTER, Danfoss 110v, <b>150T &amp; 175T</b>	1
.....	208398500		CASE, starter	1
.....	192928000		CONTACTOR	1
.....	207818004		RELAY, overload	1
13	16S06C		SCREW, cheese head	2
14	7S01		NUT	4
15	17S02		WASHER, spring	4
15A	267S03		WASHER, flat	4
16	208870000	/ Oct-04	# SWITCH, stop, assembly # <b>OBSOLETE: use 208880000</b>	1
16A	V602651	/ Oct-04	KEY, stop switch	1
16	208880000	Oct-04 /	SWITCH, stop, assembly	1
.....	208880000A	Oct-04 /	MUSHROOM key reset, c/w keys	1
.....	208880000B	Oct-04 /	CONTACTOR	1
.....	208880000C	Oct-04 /	ENCLOSURE	1
16A	V603623	Oct-04 /	KEY, stop switch	2
17	11S01C	/ Oct-04	SCREW, set	2
17	11S01D	Oct-04 /	SCREW, set	
18	133470000		PLUG, stop switch casing	1
19	131270000		COUPLING, 16mm	1
20	131570016		SOCKET, reducing	1
20A	133266050		NUT, backing	1
21	131766010		CONDUIT, 16mm	1
22	131271000		COUPLING, 20mm	2
22A	56S07		NUT, backing	1
23	131770010		CONDUIT, 20mm	1
24	131270000		COUPLING, 16mm	1
<b>110 volts</b>				
30	30788101		WIRE, black	1 meter
31	30788102		WIRE, red	1 meter
32	30788103		WIRE, green/yellow	1 meter
<b>240 volts</b>				
30	144750000		WIRE, black	1 meter
31	144700100		WIRE, red	1 meter
32	144700200		WIRE, green/yellow	1 meter

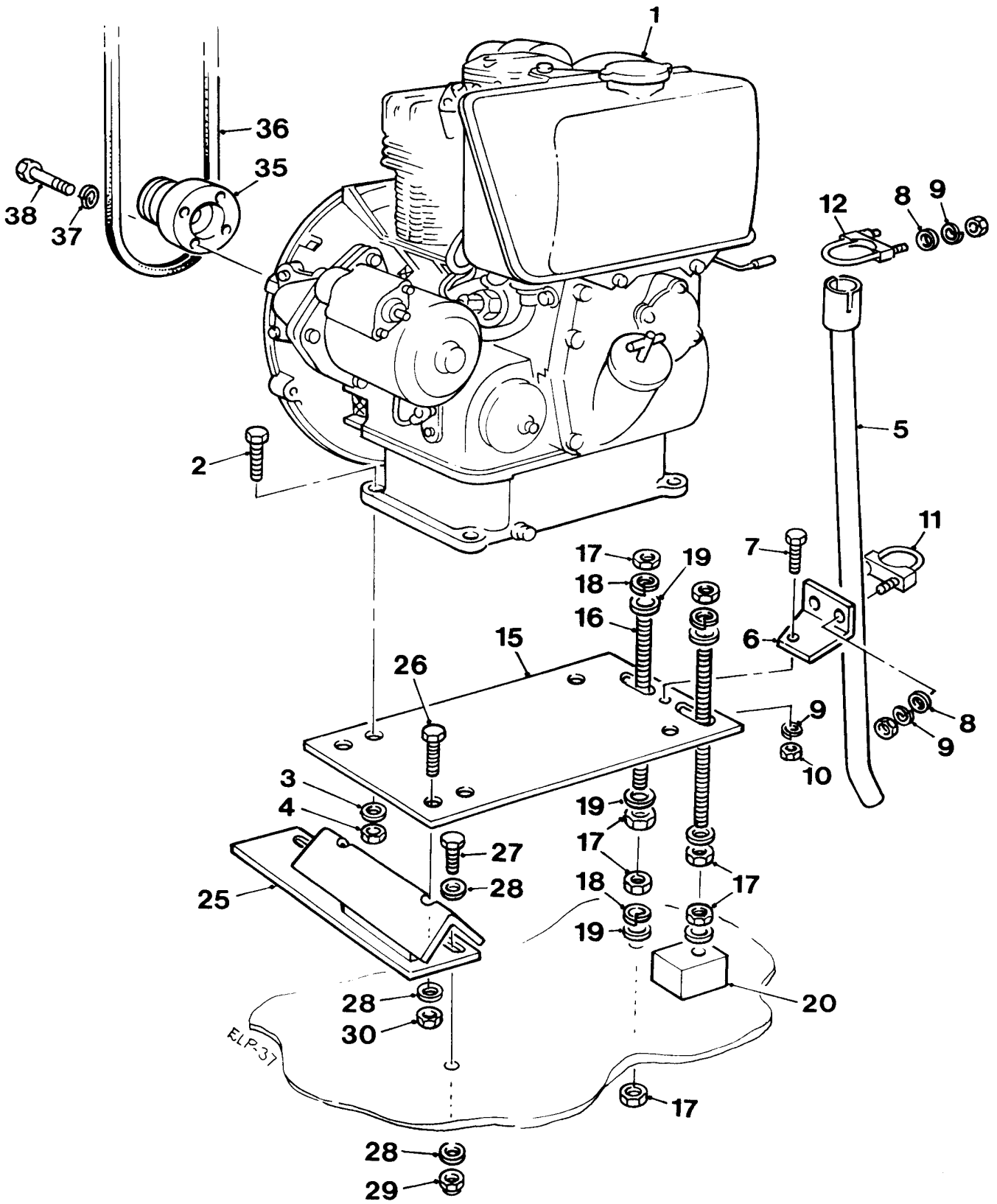

**LISTER-PETTER AC1 (electric start)****C - 4**

<b>Item</b>	<b>Part no</b>	<b>Serial no</b>	<b>Description</b>	<b>Qty</b>
1	V2004253		ENGINE, Lister/Petter AC1	1
2	11S04F		SCREW, set	4
3	267S06		WASHER, flat	4
4	61S04		NUT, self- locking "Binx"	4
5	513267500		PIPE, exhaust	1
6	513359300		BRACKET, exhaust	1
7	11S03C		SCREW, set	1
8	267S05		WASHER, flat	4
9	17S04		WASHER, spring	5
10	7S03		NUT	1
11	153S01		CLAMP	1
12	153S03		CLAMP	1
15	513358700		PLATE, engine mounting	1
16	513333100		STUD	2
17	7S05		NUT	7
18	17S06		WASHER, spring	3
19	267S07		WASHER, flat	6
20	513359000		PLATE (welded to chassis)	1
25	513358800		SUPPORT	1
26	11S04F		SCREW, set	2
27	11S04D		SCREW, set	2
28	267S06		WASHER, flat	6
29	59S03		NUT, self- locking "Nyloc"	2
30	61S04		NUT, self- locking "Binx"	2
35	513358300		PULLEY, special	1
36	397400100		BELT	1
37	41S04		WASHER, spring	4
38	6S02E		BOLT	4



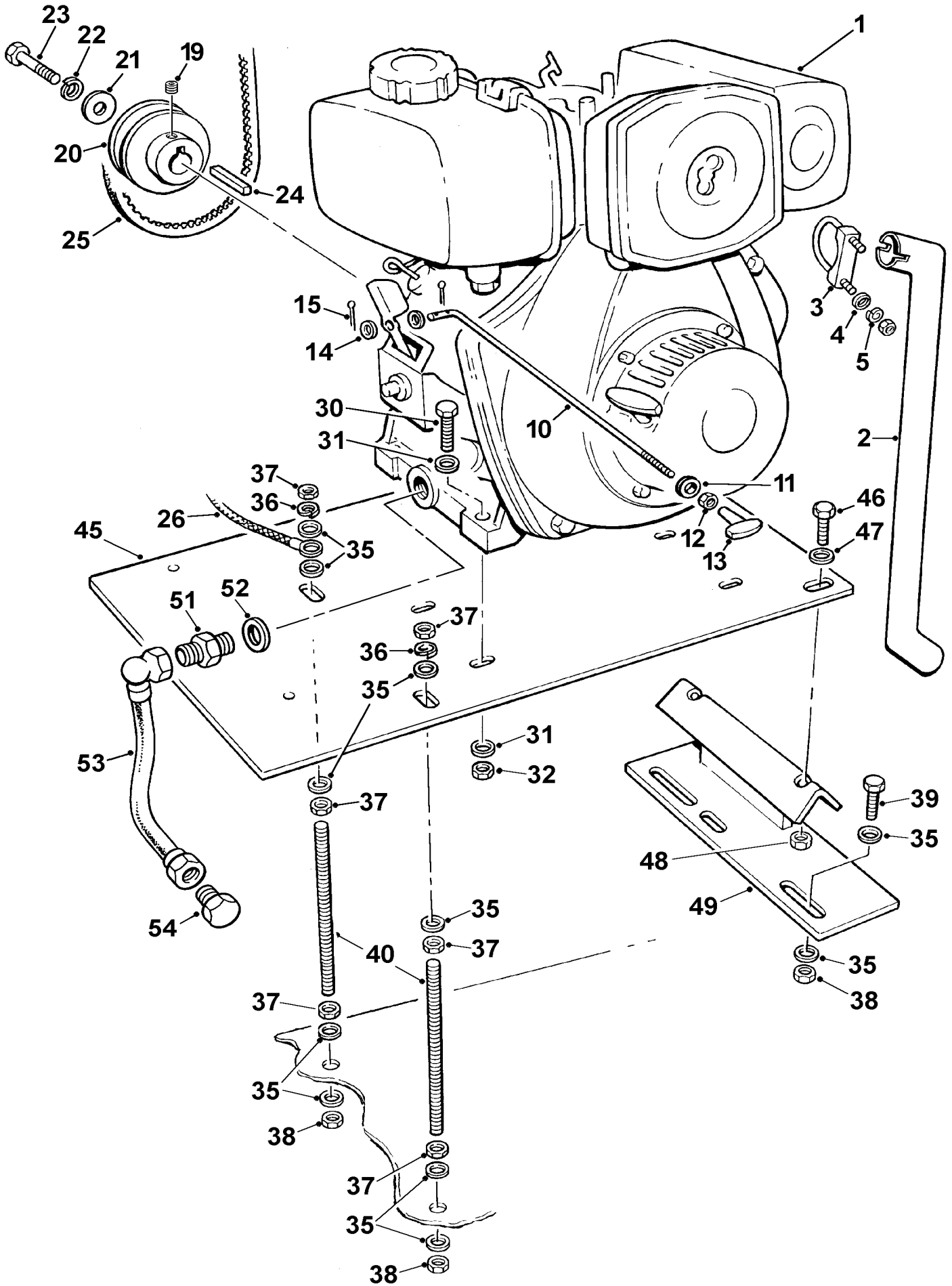

Engine & mounts

Item	Part no	Serial no	Description	Qty
<b>NOTE: For Battery, start switch &amp; loom, see page C-6</b>				
		06737 /	<b>100T</b>	
		02719 /	<b>150T &amp; 175T</b>	
1	V2005210		ENGINE, Yanmar L40A/L48A/L48N	1
<b>From Serial nos 09571-100T &amp; 05135-150T/175T L48A replaced by L48N, Engines are interchangeable, check model before ordering filters etc For Yanmar L48V5V Stage 5 Emission Compliant Engines see Page C-5A</b>				
2	513361600		PIPE, exhaust	1
3	153S02		CLAMP, exhaust	1
4	267S05		WASHER, flat	2
5	17S04		WASHER, spring	2
10	513362100	/ 07364	ROD, engine stop, <b>100T</b>	1
10	513362100	/ 03347	ROD, engine stop, <b>150T</b>	1
10	513362300	/ 03305	ROD, engine stop, <b>175T</b>	1
<i># Deleted with the above RODS (Item 10)</i>				
11	254820000	/ #	GROMMET, open ( <i>Fitted in eng. cover</i> )	1
12	7S02	/ #	NUT	1
13	V2005213	/ #	HANDLE, 'T', engine stop	1
14	267S04	/ #	WASHER, flat	2
15	44S02B	/ #	PIN, split	2
19	57S04D2		SCREW, grub	1
20	V2005220		PULLEY	1
21	V2004220		WASHER, 'Special'	1
22	17S04		WASHER, spring	1
23	8S03D		BOLT	1
24	305110550		KEY, parallel	1
25	397400200		BELT, 'V', <b>100T</b>	1
25	397400600		BELT, 'V', <b>150T &amp; 175T</b>	1
26	.....		CABLE, negative ( <i>See page C-6</i> )	1
30	8S03D		BOLT	4
31	267S05		WASHER, flat	8
32	61S03		NUT, self- locking "Binx"	4
35	267S07		WASHER, flat	13
36	17S06		WASHER, spring	2
37	7S05		NUT	6
38	61S05		NUT, self- locking "Binx"	4
39	11S05D		SCREW, set	2
40	513333100		STUD	2

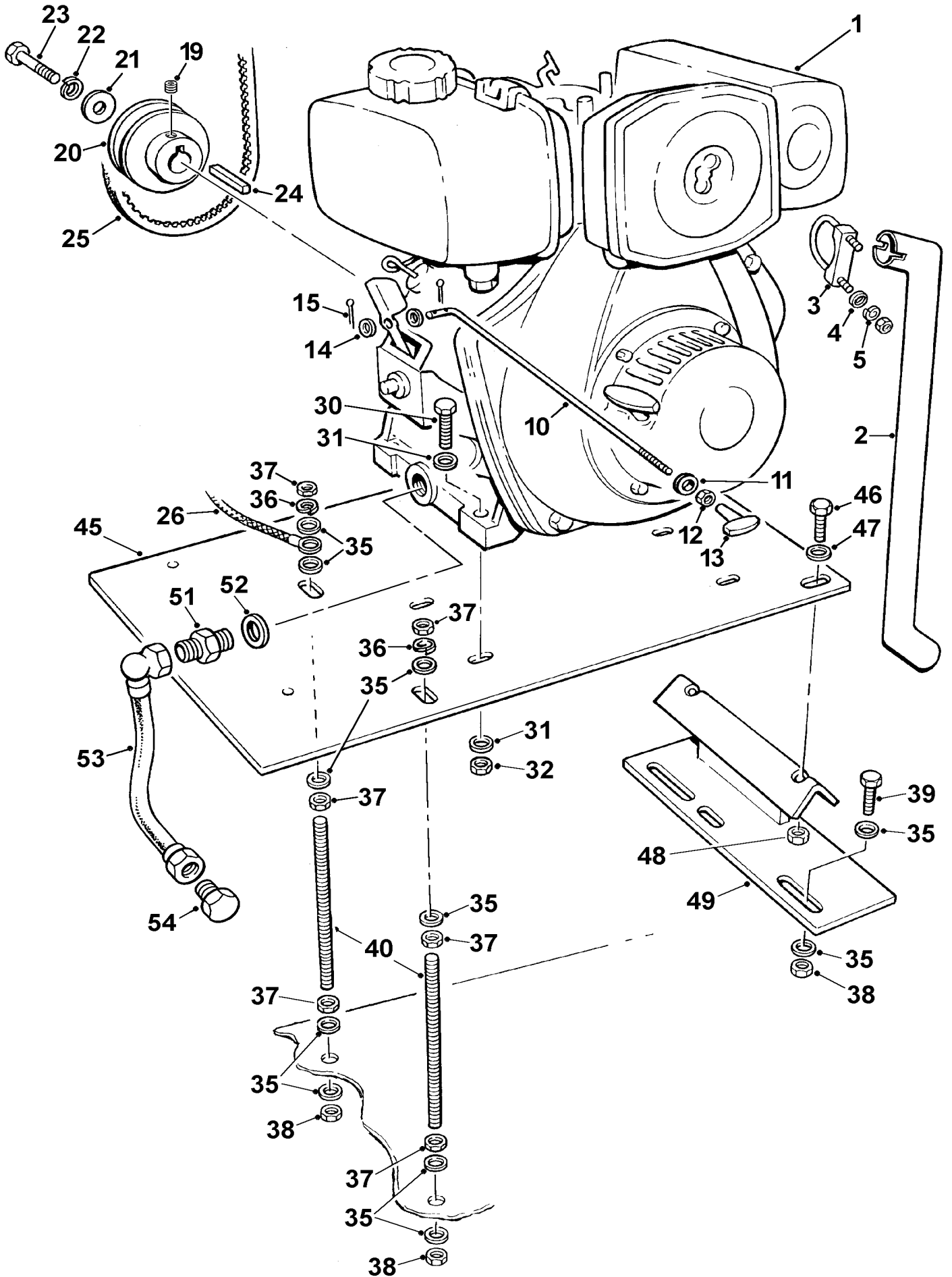

## Engine &amp; mounts

Item	Part no	Serial no	Description	Qty
45	513361800		PLATE, engine mounting	1
46	8S04D		BOLT	2
47	V2004220		WASHER, flat	2
48	61S04		NUT, self- locking "Binx"	2
49	513358800		SUPPORT, bracket	1
51	325S04	\$ /	ADAPTOR, male/male	1
52	298S05	\$ /	SEAL, bonded	1
53	31S02LL	\$ /	HOSE, hydraulic	1
54	127S03	\$ /	PLUG, blanking, engine oil drain	1

\$ *From mixer serial numbers*

07373 / **100T**  
03347 / **150T**  
03387 / **175T**

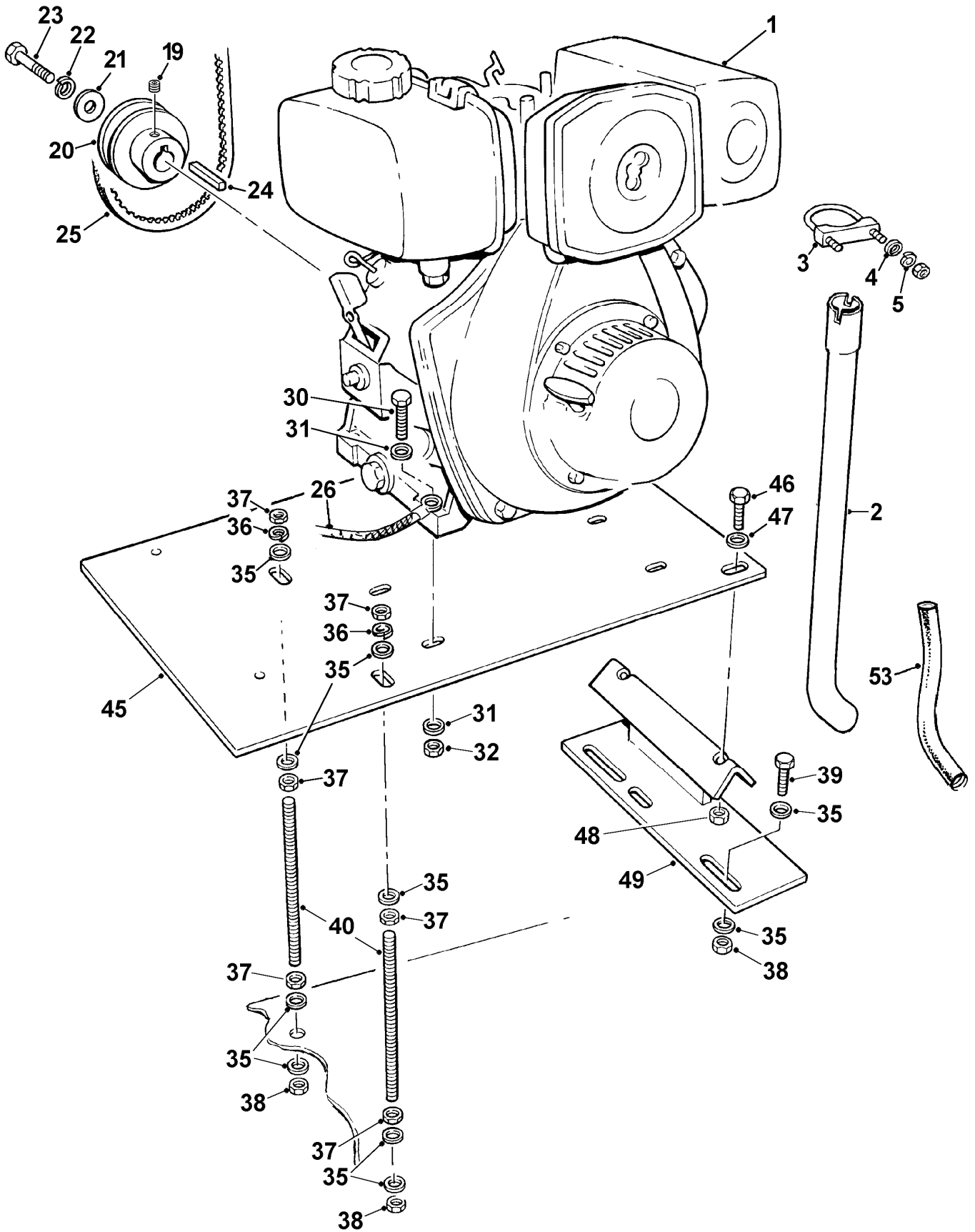

# YANMAR L48V5VSJ1 EMISSION COMPLIANT(electric start) C - 5A

## Engine & mounts

Item	Part no	Serial no	Description	Qty
<b>NOTE: For Battery, start switch &amp; loom, see page C-6</b>				
		11752 /	<b>100T</b>	
		05855 /	<b>150T</b>	
		05858 /	<b>175T</b>	
1	V2006401		ENGINE, Yanmar L48V5VSJ1,	1
2	513371300		PIPE, exhaust	1
3	153S02		CLAMP, exhaust	1
4	267S05		WASHER, flat	2
5	17S04		WASHER, spring	2
19	57S04D2		SCREW, grub	1
20	V2005220		PULLEY	1
21	V2004220		WASHER, 'Special'	1
22	17S04		WASHER, spring	1
23	8S03D		BOLT	1
24	305110550		KEY, parallel	1
25	397400200		BELT, 'V', <b>100T</b>	1
25	397400600		BELT, 'V', <b>150T &amp; 175T</b>	1
26	.....		CABLE, negative (See page C-6)	1
30	8S03D		BOLT	4
31	267S05		WASHER, flat	8
32	61S03		NUT, self- locking "Binx"	4
35	267S07		WASHER, flat	13
36	17S06		WASHER, spring	2
37	7S05		NUT	
38	61S05		NUT, self- locking "Binx"	
39	11S05D		SCREW, set	2
40	513333100		STUD	2
45	513361800		PLATE, engine mounting	
46	8S04D		BOLT	2
47	V2004220		WASHER, flat	2
48	61S04		NUT, self- locking "Binx"	2
49	513358800		SUPPORT, bracket	1
51	.....		TAP, oil drain, not illustrated (refer to engine parts manual)	1
53	29S22		HOSE,oil drain, push on, 450mm long	1

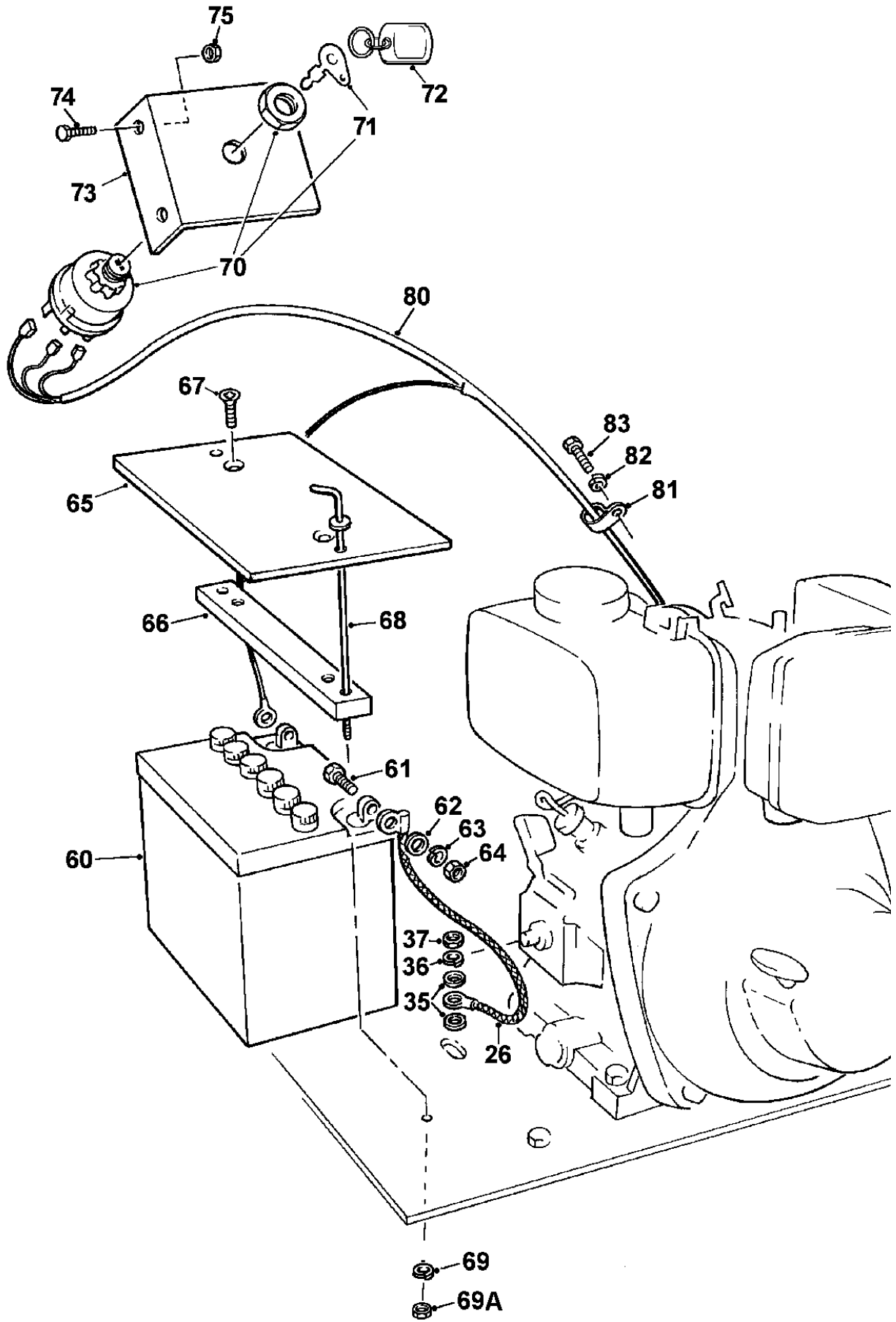

**YANMAR L40/48 ARE-SE/L48N5SJ1/L48V5V (electric start) C - 6**

**Battery, start switch & loom**

Item	Part no	Serial no	Description	Qty
		06737 / 02719 /	<b>100T 150T &amp; 175T</b>	
26	V2005211		CABLE, negative	1
35	267S07		WASHER, flat	2
36	17S06		WASHER, spring	1
37	7S05		NUT	1
60	109S11		BATTERY, 12 volt	1
61	11S02B		SCREW, set	2
62	267S04		WASHER, flat	2
63	17S03		WASHER, spring	2
64	7S02		NUT	2
65	513362000		COVER, battery	1
66	513361900		CLAMP, battery	1
67	52S02E		SCREW, counter sunk	2
68	513361700		ROD, battery clamp	2
69	17S03		WASHER, spring	2
69A	7S02		NUT	2
70	V2003561		SWITCH, start, c/w key	1
71	V601179		KEY	2
72	V2003540		KEY RING	1
73	513359200		BRACKET, start switch	1
74	11S03A		SCREW, set	2
75	61S03		NUT, self-locking, 'Binx'	2
80	513362200		LOOM	1
81	V2005209		CLIP, 'P'	1
82	17S04		WASHER, spring	1
83	11S03A		SCREW, set	1



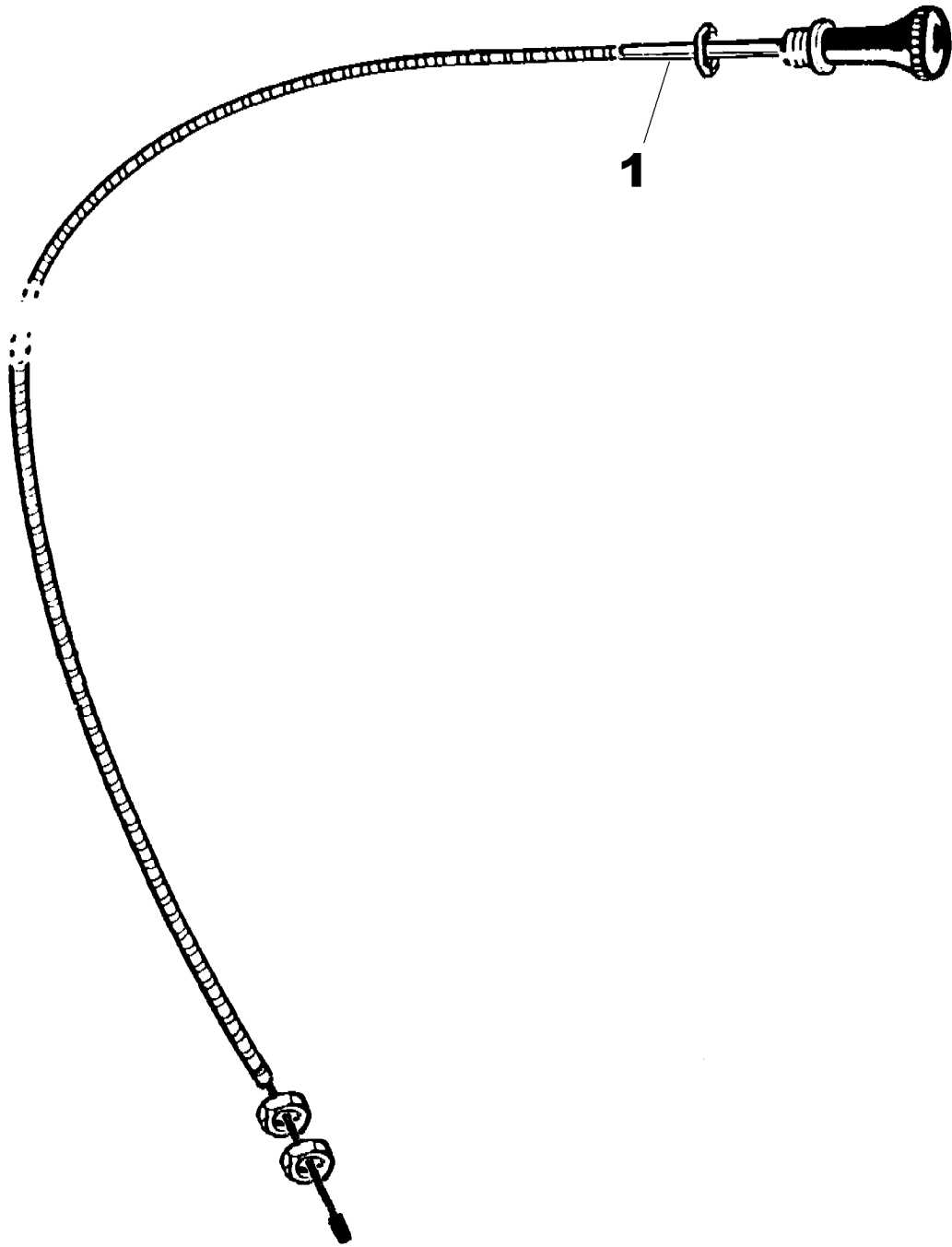

**YANMAR L48N5SJ1/L48V5V (electric start)****C - 6A****Emergency stop cable**

<b>Item</b>	<b>Part no</b>	<b>Serial no</b>	<b>Description</b>	<b>Qty</b>
		11195 /	<b>100T</b>	
		05637 /	<b>150T</b>	
		05604 /	<b>175T</b>	
1	513370900		CABLE, emergency stop	1
2	267S04		WASHER, flat	2
3	V2006398		TIE, Cable, panel mount	1

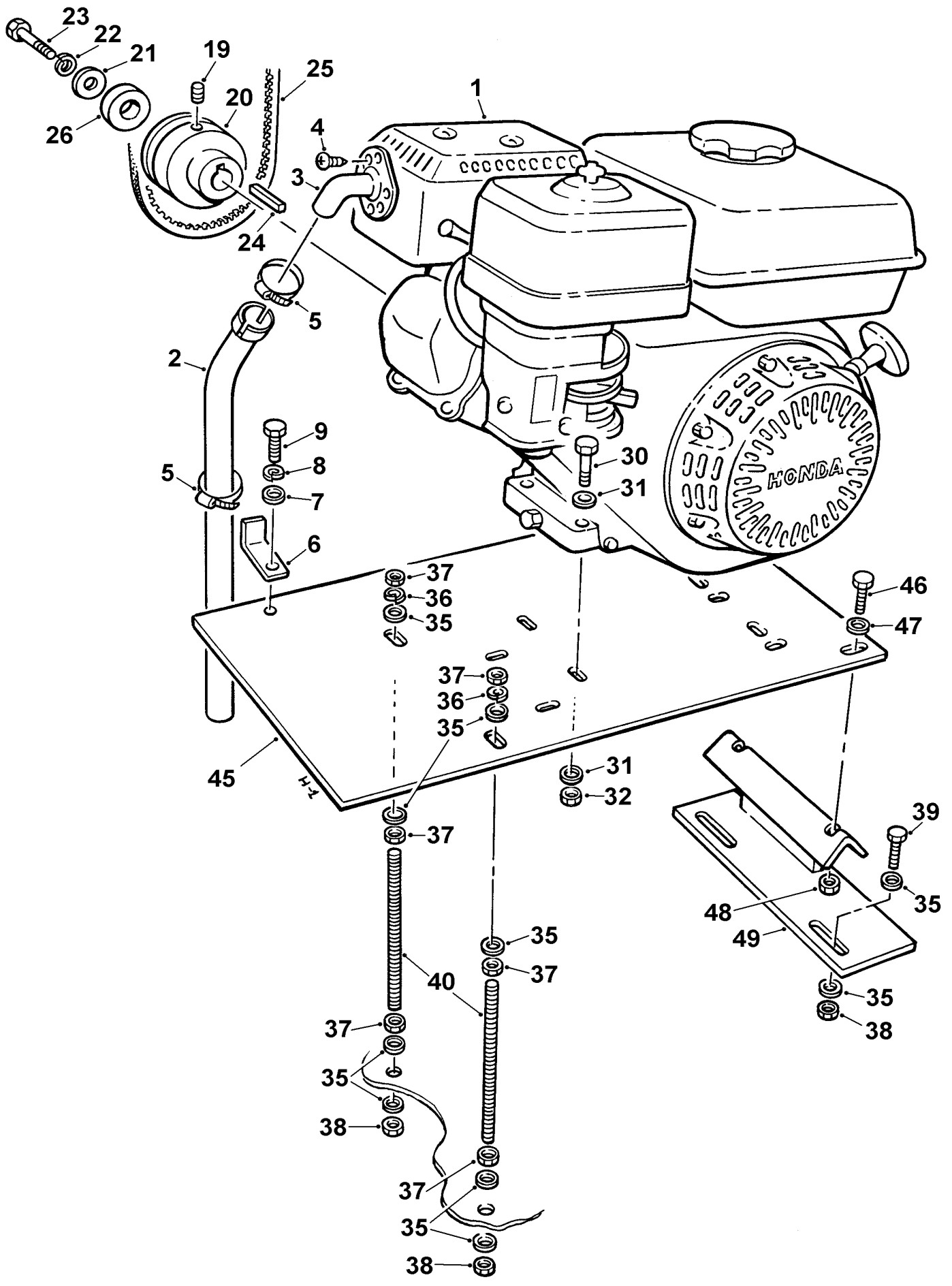

**HONDA GX160K1 (hand start)****C - 7****Engine & mounts**

<b>Item</b>	<b>Part no</b>	<b>Serial no</b>	<b>Description</b>	<b>Qty</b>
1	354073260	07395 /	ENGINE, Honda GX160K1	1
2	513363600		PIPE, exhaust	1
3	513363700		ELBOW, exhaust	1
4	214S03		SCREW, self tapping	2
5	97S05		CLIP, pipe	2
6	513363800		BRACKET, exhaust	1
7	267S04		WASHER, flat	1
8	17S03		WASHER, spring	1
9	11S02A		SCREW, set	1
19	57S04D2		SCREW, grub	1
20	513363000		PULLEY	1
21	V2004220		WASHER, 'Special'	1
22	17S04		WASHER, spring	1
23	11S03D		SCREW, set	1
24	305110550		KEY, parallel	1
25	397400400		BELT, 'V', <b>(100T)</b>	1
26	513363400		SPACER	1
30	8S03D		BOLT	4
31	267S05		WASHER, flat	8
32	61S03		NUT, self- locking "Binx"	4
35	267S07		WASHER, flat	13
36	17S06		WASHER, spring	2
37	7S05		NUT	6
38	61S05		NUT, self- locking "Binx"	4
39	11S05D		SCREW, set	2
40	513333100		STUD	2
45	513361800		PLATE, engine mounting	1
46	8S04D		BOLT	2
47	267S06		WASHER, flat	2
48	61S04		NUT, self- locking "Binx"	2
49	513364600		SUPPORT, bracket	1

2

<b>WINGET</b>		WINGET LIMITED P.O. Box 47, Church Hill, Boring, Essex, B4 6SW Tel: (01204) 475161 Fax: (01204) 475170	
Model	_____		
Serial No.	_____		
Engine No.	_____		
Capacity	Mass (kg)	_____	
SRO No.	Power (kW)	_____	
Year Of Manuf.	Eng. (rpm)	Drum (rpm)	_____

V200337  
A Siskin Group Company

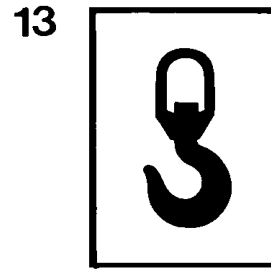

3

**DANGER**

KEEP ENGINE HOUSING  
LID CLOSED WHEN  
ENGINE IS RUNNING



4

**SAFETY WARNING**

- 1 Before starting this machine, the operator should be familiar with the operating instructions issued by the manufacturer.
- 2 The manufacturer's rated capacity must never be exceeded.
- 3 Before carrying out any maintenance, servicing, or greasing, always ensure that the engine has been switched off. Never work on a machine while it is running.

W504694600

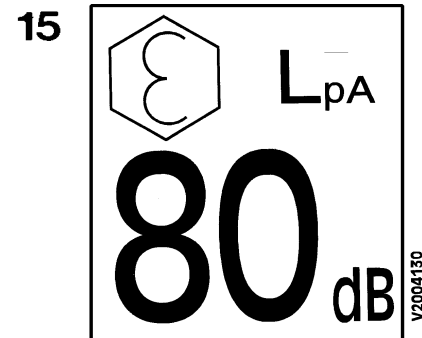

8

**WINGET**

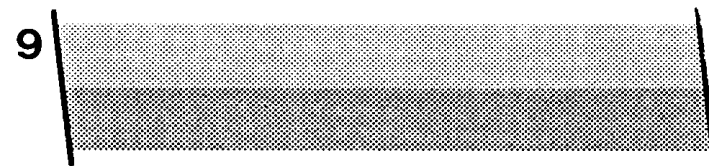
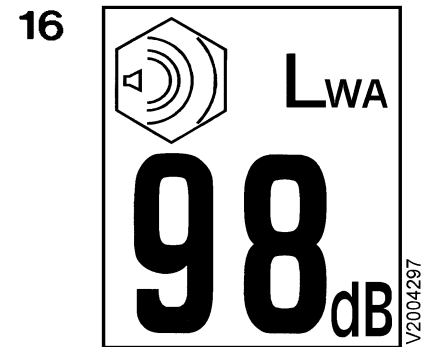

10

**DIESEL FUEL**

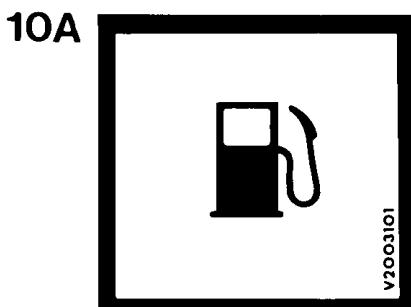

18

**FAILURE TO FOLLOW THE MANUFACTURERS INSTRUCTIONS WHEN STARTING THE ENGINE, MAY CAUSE DAMAGE TO THE MACHINE**

**DECALS & PLATES****D - 1**

<b>Item</b>	<b>Part no</b>	<b>Serial no</b>	<b>Description</b>	<b>Qty</b>
				1
2	V2003037		PLATE, serial	1
—	101S05B		RIVET. pop	4
3	504600900		DECAL, "Engine housing lid closed"	1
4	504694600		DECAL, "Safety Warning"	1
8	V2003039		DECAL, "WINGET" logo,	3
9	V2003038		DECAL, stripe, 2 colour	AR
10	—		DECAL, diesel fuel ( <i>OBSOLETE: use item 10A</i> )	
10A	V2003101		DECAL, "Diesel fuel"	1
13	V2003665		DECAL, "Sling point"	1
14	V2003598		DECAL, "British made"	1
15	V2004130		DECAL, "LPA 80"	1
16	V2004297		DECAL, "LWA 98"	1
17	V2004307		DECAL, "Electrical hazard"	1
18	V2005208		DECAL, "Engine starting procedure"	

1 **100 T**

2 **150 T**

3 **175 T**

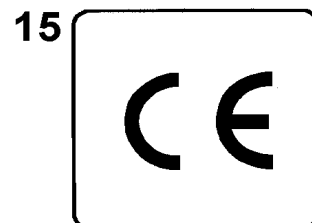
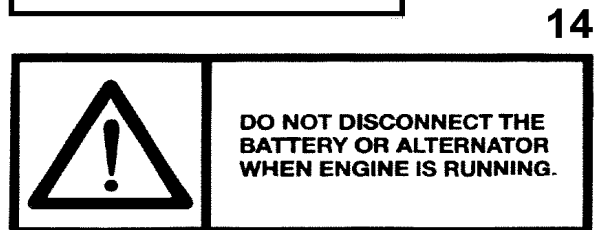
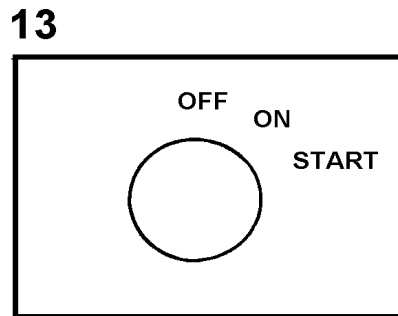
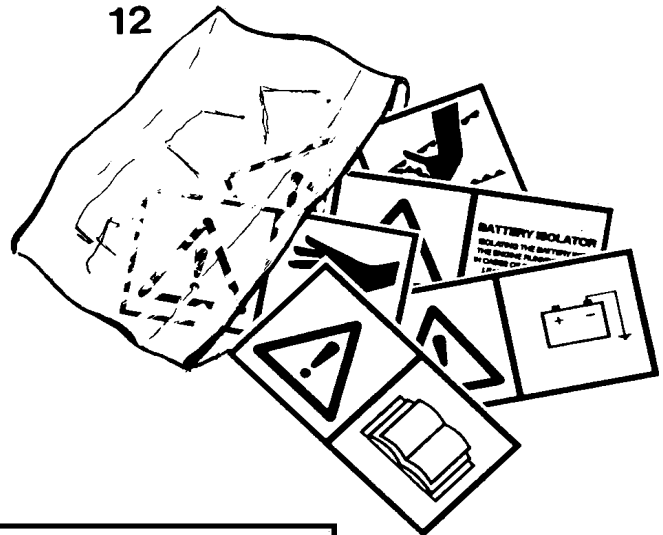
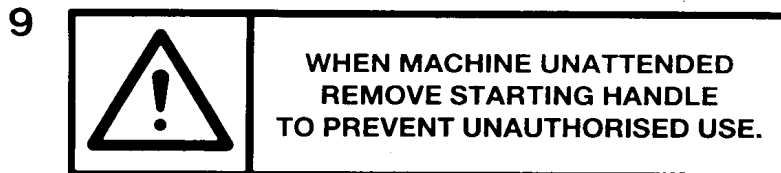
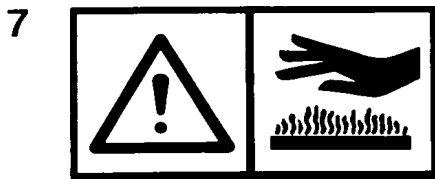
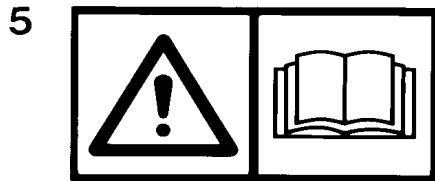
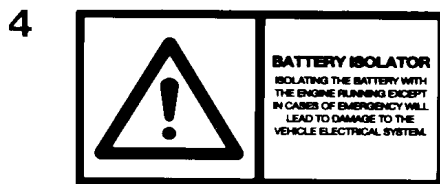
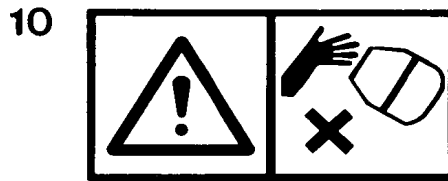

**DECALS & PLATES****D - 2**

<b>Item</b>	<b>Part no</b>	<b>Serial no</b>	<b>Description</b>	<b>Qty</b>
1	V2003105		DECAL, "100T", Black	2
1	V602436		DECAL, "100T" White ( <i>Not illustrated</i> )	-
2	V2003106		DECAL, "150T" Black	2
2	V602437		DECAL, "150T" White ( <i>Not illustrated</i> )	-
3	V2003107		DECAL, "175T" Black	2
3	V602438		DECAL, "175T" White ( <i>Not illustrated</i> )	-
4	V2004227		DECAL, "Battery isolator"	1
5	V2004229		DECAL, "Operators handbook"	1
6	V2004235		DECAL, "Negative earth"	1
7	V2004282		DECAL, "Hot surface"	1
8	V2004281		DECAL, "Chain drive"	1
9	V2004288		DECAL, "Remove start handle"	1
10	V2004289		DECAL, "Keep hands clear of drum"	1
11	V2004302		DECAL, Engine stop"	1
12	V601906		KIT, decals, 100T, 150T, 175T Each kit contains all of the decals required for one machine.	1
13	V2005218		DECAL "Key switch"	1
14	V2004796		DECAL "Do not disconnect battery"	1
15	V2004223		DECAL "CE mark"	1



1

	<p>IN COLD WEATHER, IF THE ENGINE IS HARD TO START, REMOVE THE RUBBER PLUG ON THE ROCKER COVER AND ADD NO MORE THAN 2cc OF ENGINE OIL BEFORE STARTING AS RECOMMENDED IN THE ENGINE OPERATORS HANDBOOK. ALWAYS REFIT THE RUBBER PLUG.</p> <p><small>V2005276</small></p>
---	---

2

	<p>LWA</p> <p>101 dB</p> <p><small>V2005311</small></p>
---	---

8

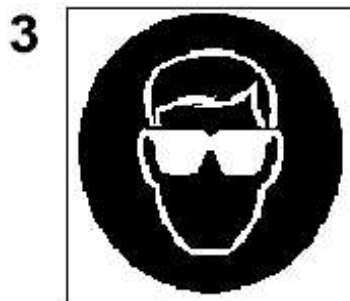

4

	<p>THE RECOIL STARTER SHOULD ONLY BE USED AS AN "EMERGENCY" MEANS OF STARTING THE ENGINE AND SHOULD BE USED WITH CARE. BE AWARE THAT STARTING THE ENGINE WITH THE RECOIL DUE TO THE ABSENCE OF THE START KEY OR BATTERY OR BECAUSE THE BATTERY IS DISCHARGED WILL RESULT IN DAMAGE TO THE ALTERNATOR.</p> <p><small>V2005214</small></p>
---	--



9



6

	<p>IMPORTANT!</p> <p>TO AVOID INJURY OR MACHINE DAMAGE DO NOT ENGAGE LOCKING PLUNGER WHILST HANDWHEEL IN MOTION</p>
---	---

7

<p>EMERGENCY STOP</p> <p>TO BE USED IN EMERGENCY ONLY</p>
---

**DECALS & PLATES****D - 2A**

<b>Item</b>	<b>Part no</b>	<b>Serial no</b>	<b>Description</b>	<b>Qty</b>
1	V2005276		DECAL, " Yanmar Engine cold starting" (Not Yanmar L48V5V Stage 5 Engine)	1
2	V2005311		DECAL, "LWA 101"	1
3	V2004744		DECAL, "Eye Protection"	1
4	V2005214		DECAL, "The recoil starter"	1
5	FSE357		DECAL, "ENGINE STOP"	1
6	V2005630		DECAL, "Locking Plunger"	1
7	513371100		DECAL, "Emergency Stop"	1
8	V2006402		DECAL "UKCA"	1
9	V2006403		DECAL "UKNI"	1

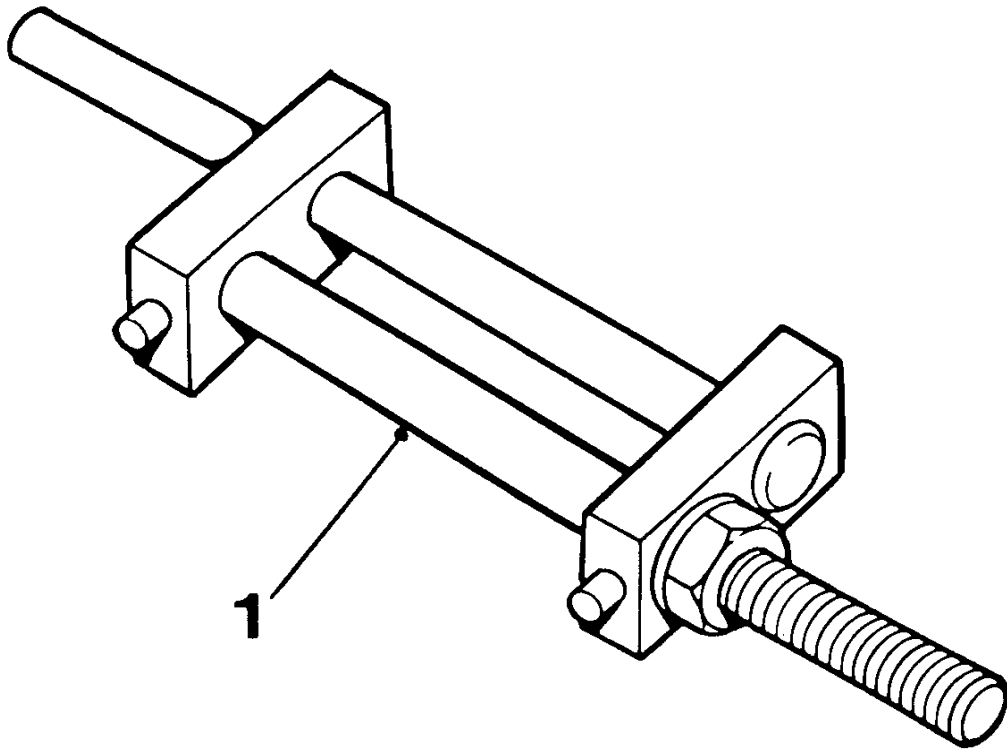

**SPECIAL TOOLS**

---

<b>Item</b>	<b>Part no</b>	<b>Serial no</b>	<b>Description</b>	<b>Qty</b>
1	513204000		CLAMP, drum clip	1



# CALIFORNIA

## Proposition 65 Warning

**Diesel engine exhaust and some of its constituents are known to the State of California to cause cancer, birth defects, and other reproductive harm**