

NEWAGE 210 SERIES AXLE SERVICE MANUAL

WINGET LIMITED
PO BOX 41
EDGEFOLD INDUSTRIAL ESTATE
PLODDER LANE
BOLTON
LANCS BL4 OLS
U.K.
Tel:++44(0)1204 854650
Fax:++44(0)1204 854663
E-mail service@winget.co.uk
www.winget.co.uk

CONTENTS

INTRODUCTION

GENERAL DESCRIPTION

IDENTIFICATION

GENERAL SERVICE INFORMATION

EXPLODED VIEW/PARTS LIST

SECTION A PINION HOUSING

SECTION B DIFFERENTIAL ASSEMBLY

SECTION C PLANET CARRIER ASSEMBLY

SECTION D AXLE ARM AND HUB ASSEMBLY

SECTION E BRAKES

SECTION F SETTING UP CROWNWHEEL AND PINION

SECTION G SPIRAL BEVEL GEAR TOOTH CONTACT

Section 1

INTRODUCTION

Introduction

Winget Limited gratefully acknowledge the assistance given by Newage Transmissions Limited in the preparation of this manual, however neither Winget Limited or Newage Transmissions can be held responsible for any errors or omissions.

The procedures described within this manual should enable experienced service personnel to strip, repair and re-build Newage 210 series axles fitted to Winget 4S range site dumpers in a safe and competent manner. The procedures are not intended to be used by personnel who are unfamiliar with the product or mechanically inexperienced.

It is assumed that personnel are aware of the Health and Safety Regulations which should be applied but the following should act as a reminder.

Whenever possible any repairs or service should be carried out in a clean environment. If work must be carried out on site or in the field steps should be taken to ensure that dirt or foreign materials cannot enter the assembly.

Ensure all work tools are in good condition and only use the correct tool for the job in hand.

Always wear safety spectacles when using soft or hard faced hammers, chisels, drifts or when using air tools. Wear safety spectacles when cleaning components or when grinding.

Do not misuse air lines and be aware of the damage compressed air can cause if misused.

Always make sure lifting equipment is in good condition and the Safe Working Load exceeds the weight of the component to be lifted.

Always use suitable supports i.e. axle stands or baulks of timber in conjunction with hydraulic jacks etc. Never rely on hydraulic jacks alone to support a machine.

Be aware of hot surface temperatures and take care when draining hot oils. Always dispose of waste oils in accordance with local and national regulations.

Whenever possible always disconnect the battery or battery isolator when working on the machine to prevent electrical shorts and unauthorised starting.

Refer to the operators handbook for a guide to the correct sequence for assembling components and sub-assemblies.

Oils, fuels, silicone sealer etc can cause skin diseases if allowed to contaminate the skin. Always apply barrier creams, wear suitable protective clothing or when contamination is unavoidable clean the area with soap and water as soon as possible. Do not use thinners or other solvents to clean skin.

Health and Safety is a matter of common sense. If common sense is applied correctly the risk of accidents can be reduced.

Spares for Newage Axles fitted to Winget Equipment can only be obtained from Winget Limited or one of our authorised distributors and not from Newage Transmissions

Limited. Always quote your machines serial number and model together with axle serial number and model when ordering spare parts.

210 Series axles are designed to operate under arduous conditions and providing they are regularly and correctly maintained they will provide long trouble free service.

Whilst every effort is made to ensure the contents of this manual are accurate Winget Limited and Newage Transmissions reserve the right to alter specification without prior notification and certain sections of this manual may then no longer apply.

Section 2

GENERAL DESCRIPTION

General Description

The 210 Series is a double reduction drive axle with integral long life oil immersed multiplate disc brakes.

Housed within the central casing are the spiral bevel crownwheel and pinion assembly, the crownwheel being mounted on a four pinion differential. The central casing also contains the oil immersed brake assemblies and the planetary reduction gears.

The axle half shafts are fully floating and the wheel hubs run on opposed taper roller bearings.

The approximate weight is 116kg (255lb)

Section 3

IDENTIFICATION

Identification

A plate is attached to the centre housing of each axle on which are stamped details of the axle specification (see illustration below) and the axle serial number.

If you require spares, both numbers on the plate should be quoted together with the machine model and serial number.

The model number allocated to each axle describes the basic specification as follows:-

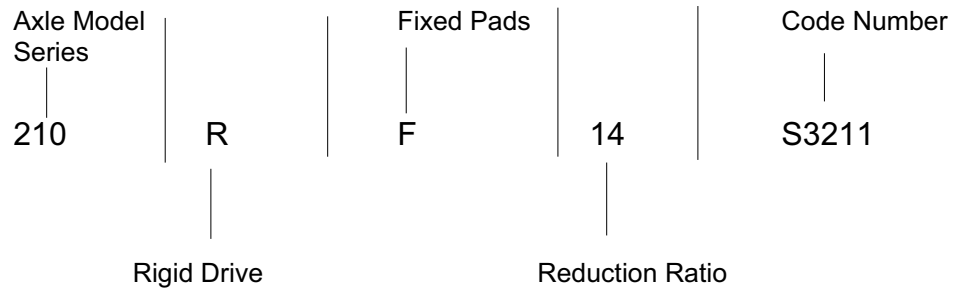

Section 4

GENERAL SERVICE INFORMATION

General Service Information

Routine maintenance

<u>Check</u>	<u>Interval</u>
For oil leaks around joints and seals	Weekly/50 hours
Wheel nut tightness	Daily/8 hours
Hub bearing adjustment hours	12 Monthly/1000
Axle arm/centre case nuts	Weekly/50 hours
Halfshaft securing nuts	Weekly/50 hours
Propshaft nuts and bolts	Weekly/50 hours
Brake pipe connections	Weekly/50 hours

Lubricants

The oils used must have the correct additives to be compatible with the mineral oil braking system, therefore, only those lubricants shown below or their direct equivalents must be used.

Mobil Fluid 422
Agricastrol As Special
Esso Torque Fluid 56 or 62
Gulf Universal Tractor Oil
Total Universal Plant Oil
Total Transmission Mp

The oil is added via the combined filler/level plug located in the face of the centre housing on the opposite face from the input flange.

The oil capacity is approximately 3.5 Litres (6 pints)

Greases

The areas listed below should be lubricated and packed with grease during overhauls or repairs.

- 1) Hub oil seals, between the V ring seal and hub oil seal.
- 2) Input pinion oil seals.

Using one of the following greases or their equivalents:-

Mobil grease MP
Esso Beacon 2
Total Multis EP2

Brake Fluid

The oil immersed brakes are operated using a mineral hydraulic fluid. On no account must a vegetable based brake fluid be used otherwise all braking system seals will be damaged.

Whenever the brakes are serviced it is essential that the cylinder bores, pistons and seals are cleaned before assembly and lubricated using one of the following mineral oils or equivalent.

Total Azzola ZS46

Total Azzola ZS22

Shell Tellus 27

Mobil DTE 24

Esso Nuto H32

Liquid Sealants

On assembly the following mating surfaces should be coated as indicated. Under no circumstances should Silicone RTV Compound be used on the Pinion Housing/Cartridge or the Axle Arm to Case Joints.

Pinion Housing/Cartridge to Maincase

Hermatite

Axle Arm to Main Centre Housing

Hermatite

Stub Axle to Axle Arm
(Where applicable)

Hermatite

Halfshaft to Hub
Compound

Silicone RTV

Tightening Torques

Description

Torque

	Kpm	(lbft)
Differential Crownwheel Nuts	5.6	40
Caphead Screws Through Differential	5.6	40
Nuts and Bolts Differential Bearing Housing to Maincase	5.6	40

Description

Torque

	Kpm	(lbft)
Pinion Housing to Maincase Setscrews	5.6	40
Axle Arm to Maincase Nuts	5.6	40
Halfshaft to Hub Nuts	5.6	40
Hub Assembly Ring Nut	14	100

Wheel Nuts 5/8 BSF	25	180
Wheel Nuts 18mm	28	200
Brake Pipe Adaptor	2.8	28

NEWAGE TRANSMISSIONS: TORQUE VALUES FOR FASTENERS WITH CLEAN & DRY THREADS

IMPERIAL IN POUNDS-FEET (LBF-FT) PLAIN THREADS												
GRADE S			GRADE V				GRADE X					
SIZE	NOM.	MAX.	MIN.	NOM.	MAX.	MIN.	NOM.	MAX.	MIN.	NOM.	MAX.	MIN.
1/4	8	10	7	11	13	10	14	16	12			
5/16	17	19	14	23	26	19	28	32	23			
3/8	30	35	26	41	47	35	50	58	43			
7/16	48	55	40	65	75	55	79	91	67			
1/2	73	84	62	100	115	85	121	140	103			
5/8	146	168	124	200	230	170	243	279	206			
3/4	255	294	217	349	402	297	423	487	360			
1"	606	696	515	829	953	704	1004	1155	853			

METRIC IN NEWTON/METRES (Nm) PLAIN THREADS												
GRADE 8.8			GRADE 10.9				GRADE 12.9					
SIZE	NOM.	MAX.	MIN.	NOM.	MAX.	MIN.	NOM.	MAX.	MIN.	NOM.	MAX.	MIN.
5	6	7	5	8	9	7	10	11	8	10	11	8
6	10	11	8	14	16	12	17	19	14	17	19	14
8	24	28	20	33	37	29	40	47	34	40	47	34
10	48	56	40	67	77	57	80	92	68	80	92	68
12	83	96	72	115	130	100	140	161	119	140	161	119
16	206	210	160	280	320	240	347	399	295	347	399	295
20	401	450	340	560	640	480	677	779	576	677	779	576
24	694	770	570	920	1040	800	1171	1347	995	1171	1347	995

IMPERIAL IN POUNDS-FEET (LBF-FT) COATED THREADS, ZINC & ZINC PASSIVATED												
GRADE S			GRADE V				GRADE X					
SIZE	NOM.	MAX.	MIN.	NOM.	MAX.	MIN.	NOM.	MAX.	MIN.	NOM.	MAX.	MIN.
1/4	10	12	9	14	16	12	17	20	15			
5/16	21	24	18	28	33	24	35	40	29			
3/8	38	43	32	52	59	44	63	72	53			
7/16	59	68	51	81	94	69	99	113	84			
1/2	91	105	78	125	144	106	152	174	129			
5/8	183	210	156	250	288	213	303	349	258			
3/4	319	367	271	437	502	371	529	609	450			
1"	757	871	643	1036	1191	881	1255	1443	1067			

METRIC IN NEWTON/METRES (Nm) COATED THREADS, ZINC & ZINC PASSIVATED												
GRADE 8.8			GRADE 10.9				GRADE 12.9					
SIZE	NOM.	MAX.	MIN.	NOM.	MAX.	MIN.	NOM.	MAX.	MIN.	NOM.	MAX.	MIN.
5	7	8	6	10	12	9	12	14	10	12	14	10
6	12	14	10	17	20	15	21	24	18	21	24	18
8	30	34	25	42	48	36	51	58	43	51	58	43
10	59	68	50	84	96	71	100	115	85	100	115	85
12	104	119	88	146	168	124	175	201	149	175	201	149
16	257	296	219	362	416	307	434	499	369	434	499	369
20	502	577	426	706	811	600	847	974	720	847	974	720
24	868	998	737	1220	1403	1037	1464	1684	1244	1464	1684	1244

Section 5

EXPLODED VIEWS

AXLE 210RF

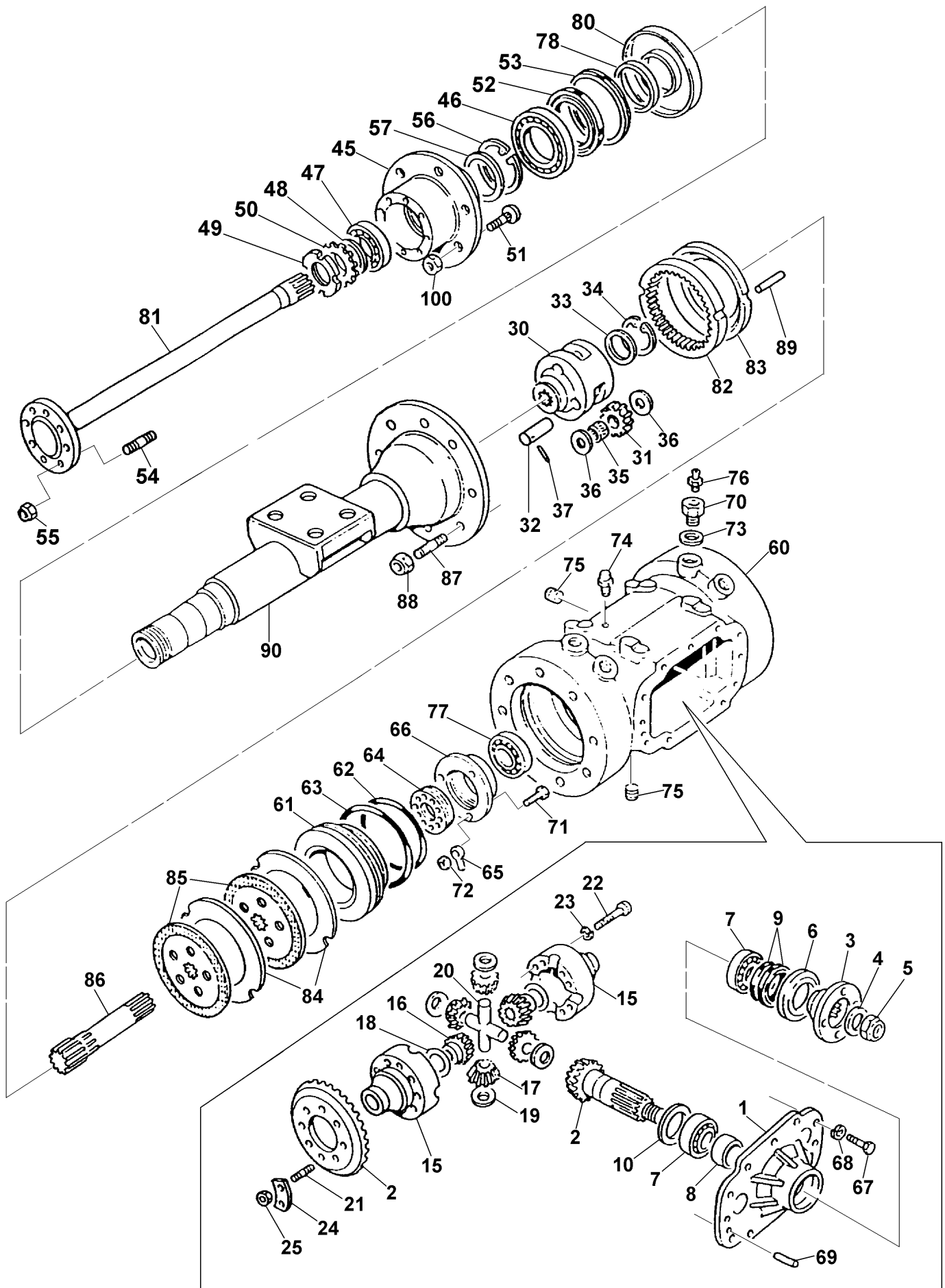

AXLE 210RF

Item No	Description	Qty
AXLE, type 210RF14S3211 shown		
Bevel Wheel & Pinion Assembly		
1	HOUSING, pinion	1
2	BEVEL WHEEL & PINION	1
3	FLANGE, input drive	1
4	WASHER	1
5	NUT	1
6	COVER, seal	1
7	BEARING	2
8	SPACER	1
9	SEAL, oil	2
10	SHIM, 0.25mm	AR
10	SHIM, 0.30mm	AR
10	SHIM, 0.40mm	AR
Differential assembly		
15	CASING, differential, matched two halves	1
16	WHEEL, differential	2
17	PINION, differential	4
18	WASHER, thrust, differential wheel	2
19	WASHER, thrust, differential pinion	4
20	SPIDER	1
21	STUD	8
22	SCREW, cap head	8
23	WASHER, spring	8
24	STRIP, locking	4
25	NUT	8
Planet Carrier assemblies		
30	CARRIER, planet gears	2
31	GEAR, planet	6
32	PIN, planet gears	6
33	SPACER, axle shaft	2
34	CIRCLIP	2
35	BEARING, needle roller	6
36	WASHER, thrust	12
37	DOWEL	6
Hub assemblies		
45	HUB	2
46	BEARING, hub inner	2
47	BEARING, hub outer	2
48	SPACER	2
49	LOCKNUT	2
50	WASHER, locking	2

AXLE 210RF

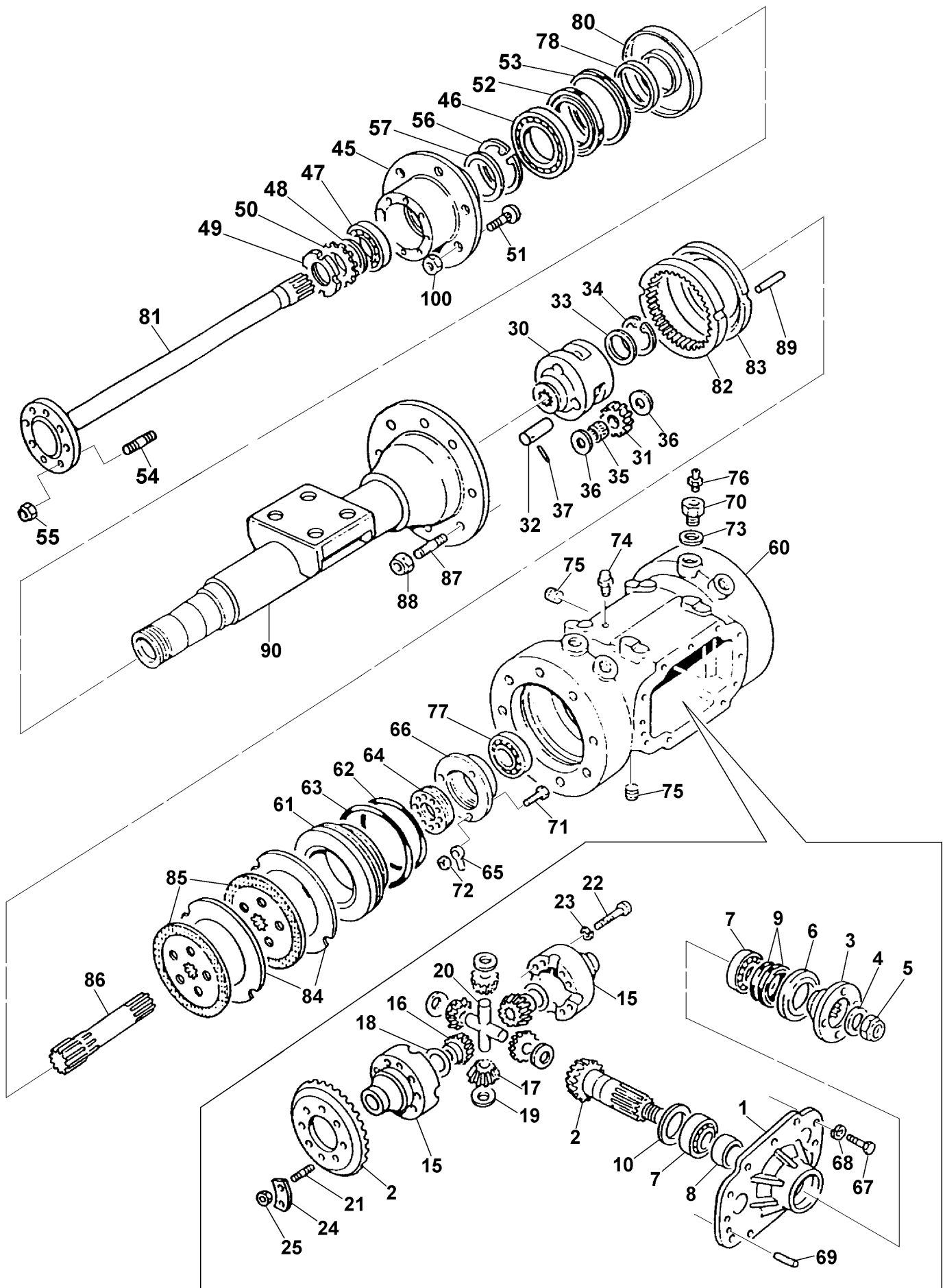

AXLE 210RF

Item No	Description	Qty
AXLE, type 210RF14S3211 shown		
Hub assemblies, <i>continued</i>		
51	STUD, wheel	12
52	SEAL, oil	2
53	SEAL, 'V' ring	2
54	STUD	16
55	NUT, nylon insert	16
56	CIRCLIP	2
57	SPACER	2
Main casing		
60	CASING, main	1
61	PISTON, brake	2
62	SEAL, 'O' ring	2
63	SEAL, 'O' ring	2
64	NUT	2
65	PLATE, locking	2
66	HOUSING, BEARING	2
67	SCREW, set	12
68	WASHER, spring	12
69	DOWEL	2
70	ADAPTOR, brake pipe	4
71	SCREW	6
72	NUT	6
73	SEAL, bonded	4
74	VALVE, breather	1
75	PLUG, socket	2
76	VALVE, brake bleeding	1
77	BEARING	2
78	SLEEVE	2
General parts		
80	COVER, oil seal	2
81	SHAFT, axle	2
82	ANNULUS	2
83	SPACER	2
84	PLATE, brake	2
85	PLATE, disc	4
86	GEAR, sun	4
87	STUD	2
88	NUT	20
89	DOWEL	20
Axle arms		
90	CASING, axle arm	2
100	NUT, wheel	12

Section A

PINION HOUSING

Servicing the Pinion Housing Assembly

Section A

Place a suitable container below the axle drain plug underneath the centre housing, remove the plug and drain the oil. Dispose of the oil safely in accordance with local bylaws and national regulations.

Remove the setscrews securing the pinion housing to the centre casing and lift off the assembly. The housing is located on dowels and will require carefully prising apart from the centre casing using a pry bar or other suitable tool.

Prevent the flange from turning and undo and remove the self locking nut and flat washer securing the flange to the pinion, using a suitable puller or drift, remove the flange and gently drift the pinion shaft out through the housing. Take care to avoid damaging the gear teeth, splines or threads. Prise the oil seals out of the housing, slide the old collapsed spacer off the shaft and discard the spacer.

Note:- A new spacer should always be fitted.

Inspect the bearings for wear or damage, check the teeth on both the crownwheel and pinion and make a visual check through the differential of the "wheels". If the front bearing race on the pinion shaft needs replacing use a suitable bearing puller to avoid damaging either the shaft or the shim pack sandwiched between the pinion head and bearing. If the outer cones require replacing they can easily be drifted out of each end of the housing.

Important:- If new pinion bearings are fitted check the crownwheel/pinion backlash, see Section F "Crownwheel/Pinion Set up" If a new pinion or housing is being fitted refer to Section F before proceeding any further.

To reassemble the housing reverse the above procedure fitting a new collapsible spacer, install the pinion shaft through the innermost bearing cone and fit the rear bearing over the pinion shaft. Carefully fit the new oil seals and pack with one of the recommended greases. Refit the flange, coat the inner surface of the flat washer with silicone sealer and loosely refit the washer and self locking nut.

Prevent the flange from turning and tighten the nut until the spacer begins to collapse and all the end float between the pinion bearings is taken up, but without pre-loading the bearings.

Slowly continue to tighten the nut, frequently checking the preload, until a preload of 6-10kg (13.2-22lbs) for new bearings or 3-6Kg (6.61-13.2lbs) for used bearings is obtained. The preload is measured by winding a length of string round the flange and measuring the load required to turn the flange with a spring balance. Care should be exercised when tightening the pinion nut otherwise the required preload will quickly be exceeded.

If the old bearings have been reused coat the mating surfaces of the centre casing and pinion housing with the recommended sealant and refit the housing to the axle.

If new bearings have been fitted refer to Section F making a note of the pinion preload setting as it will be required later

Refit the drain plug and tighten, remove the combined filler/level plug located midway up the face of the centre housing and fill the axle with one of the recommended oils. Refit and tighten the level plug.

Section B

DIFFERENTIAL ASSEMBLY

Servicing the Crownwheel and Differential Assembly

Section B

Refer to sections A,C,D and E and remove the pinion housing, axle arm, planet carrier and brakes.

Undo the nuts and bolts securing the bearing housings and withdraw the bearing housings. The housings are provided with threaded holes into which jacking screws can be inserted to aid removal of the housing (unless new differential bearings are to be fitted do not disturb the position of the bearing adjusting nuts with the bearing housings). The differential/crownwheel assembly can be removed through the pinion housing opening in the centre case. Mark the centre casing so that the differential assembly is correctly re-assembled into the same end of the centre casing. (Assembling the crownwheel into the opposite end of the centre casing from which it was removed will result in the rotation of the axle being reversed).

Free the locking washers and undo the nuts securing the crownwheel to the differential, remove the crownwheel. Remove the cap headed screws securing the two halves of the differential and separate the assembly, remove the pinions, wheels, thrust washers and spider.

Examine the bearings, wheels, pinions, thrust washers, spider and crownwheel for wear or damage and replace as necessary.

Assemble in reverse order ensuring that no dirt or foreign objects enter the assembly. Align any indent marks on the differential casing halves, refit the cap headed screws and spring washers, torque up the screws. Refit the crownwheel, fit new lockwashers, torque up the nuts and bend over the lockwashers.

If new differential bearings have been fitted it is necessary to check both the bearing preload and the crownwheel/pinion backlash as described in section F.

If the bearings are not replaced the bearing housings should be fitted in their original position without turning the adjusting ring nuts and there is then no need to recheck either the backlash or preload. Secure the ring nuts with the locking tabs and re-torque the nuts and bolts securing the bearings housings.

Refer to sections A, C,D and E and reassemble the axle.

Refill the axle with oil.

Servicing the Planet Carrier Assembly

Section C

To gain access to the planet carrier remove the axle arm as described in section D.

Remove the shield and carefully lift out the planet carrier without disturbing the sungear. Check the teeth on both the annulus and sun gear for wear or damage. Check the planet gear for wear or damage. Check the planet gears within the planet carrier, the gears should run freely on the pins without excessive radial play.

To replace the planet gears, pins or bearings, drift the small spring dowel pins which retain the planet pins into the centre of the pins and lightly drift the planet pins out of the carrier. The axle shaft thrust washer is retained by a circlip which can be removed to allow inspection of the washer.

Before re-assembling the unit remove the old spring dowels from the planet pins and ensure new spring dowels are fitted on assembly.

If necessary the annulus which is retained in the casing by dowels can be withdrawn. If the annulus is replaced the dowels should also be replaced, ensure the annulus is fitted squarely into the case on assembly.

Locate the planet carrier back in the centre casings engaging the teeth on the annulus and sun gear.

Refit the axle arm assembly as described in section D.

Remove the combined filler/level plug and top up the axle with oil.

Section D

AXLE ARM & HUB ASSEMBLY

Servicing the Axle Arm and Hub Assembly

Section D

The hub assembly and halfshaft can be serviced with the axle still in situ on the machine, however, it is recommended that the axle be removed from the machine before the axle arm is removed.

The Hub Assembly

Remove the self locking nuts securing the halfshaft to the hub and withdrawn the shaft. (A drip tray placed below the hub will catch any oil which runs from the hub). Inspect the splines for wear or damage and the shaft for signs of twist or distortion.

Straighten the locking tabs on the lockwasher securing the ring nut, undo the the ring nut and remove the nut, lockwasher and spacer. The hub can now be withdrawn off the opposed taper roller bearings.

Remove the V seal on the circumference of the rear of the hub, prise out the oil seal and lift out the rear most bearing race, inspect the bearings for damage or wear and replace if necessary. The cones can be simply drifted out of the hub, however, ensure that replacements are square to the bores before refitting. The replacement oil seal must be packed with grease and the V ring seal lubricated with a little oil or grease. (A new oil seal must be fitted regardless of visual condition).

If the oil seal housing is damaged or the seal contact area worn it can be drifted off the axle arm. When fitting the replacement care must be taken not to damage the oil seal contact area or distort the housing. Apply "loctite" grade 601 or equivalent to both the axle arm and seal housing mating surfaces before assembly.

To reassemble the hub reverse the procedure, lightly oil the V seal and bearings before reassembly, fit a new lockwasher.

To Adjust the Hub Bearings

Tighten the ring nut upto a torque of 14Kpm (100lbft). Turn the wheel hub in each direction at least three times to ensure the bearings have correctly "seated" in and re-check the torque (this operation should be repeated until the locknut no longer turns when rechcking the torque). Slacken the ring nut back a distance equal to 1 tab of the lockwasher then turn down a tab into the nut to secure the ring nut in place.

Coat the mating surfaces of the hub and halfshaft with the recommended sealant. Refit the halfshaft, it may be necessary to turn the hub slightly to engage the splines on the halfshaft with the planet carrier within the axle case. Torque up the self locking nuts.

Remove the combined filler/level plug and top up the axle oil.

Axle Arm Removal

It is recommended that the axle is removed from the machine before the axle arm is removed.

Drain the oil from the axle as described under section A, whilst it is possible to remove the axle arm with the halfshaft in place it is strongly recommended that the halfshaft be removed as previously described.

Support the weight of the axle arm and remove the ring of self locking nuts round the flange of the axle arm. (Place a drip tray below the axle and case to catch any oil which may run out). Withdraw the axle arm taking care not to dislodge the planet carrier.

Reverse the procedure to reassemble, coating the mating surfaces of the axle arm and casing with the recommended sealant.

Torque up the self lock nuts. Remove the combined filler/level plug and top up the axle oil.

Section E

BRAKES

Brakes

Section E

Note the brakes operate on a mineral hydraulic fluid. On no account must a vegetable based brake fluid be used otherwise all braking system seals will be damaged.

To gain access to the brake components it will be necessary to refer to sections D and C and remove the axle arms and planet carriers.

Withdraw the sun gears, annulus and brake spacer plate, lift out the brake friction discs and brake fixed plates (plain). Withdraw the brake piston from the cylinder machined into the case and remove the seals. The brake piston seals should be replaced even if visually in good condition, ensure replacement seals are suitable for use with mineral hydraulic fluid.

Examine all parts for wear or damage, under normal operating conditions the brake plates should last several years, but should be replaced if blued, distorted or badly scored or the wear exceeds the limits given below.

Blueing of the brake plates indicates that the brakes have been overheating and slipping. Both sets of plates, plain and sintered bronze, should be replaced and the piston seals renewed.

Distortion normally occurs in conjunction with blueing and again indicates that the brakes have been overheating and slipping. Both sets of plates, plain and sintered bronze should be replaced and the piston seals renewed.

Scoring of the plates indicates that there are loose particles or foreign material suspended in the oil. The axle casing should be thoroughly cleaned out and if necessary the source of the particles or material should be investigated. Both sets of plates, plain and sintered bronze should be replaced and the axle refilled with clean oil.

Wear, if the sintered groove of the bronze brake disc is worn down to a depth of .025 inch, 0.6mm or less, then the plates have reached the end of their working life and should be replaced. Care should be taken when examining the plain brake plates for over a long period of operation these can show a greater degree of wear than the sintered bronze disc. Do not assume because the bronze disc is well within the wear limits that all the brake plates are in an acceptable condition. Replacing the plain brake plates may prolong the working life of the brakes and restore their efficiency.

Lubricate all the components with one of the recommended mineral oils, carefully refit the brake piston taking care not to "nip" the "O" rings.

Refit the brake plates into the axle ensuring that a plain fixed plate is installed first up against the brake piston, (note the fixed discs locate on the dowels in the walls of the case), followed by a friction disc, alternate the disc's ensuring a plain fixed disc is between each friction disc, ensure that the last plate fitted is a friction disc which will butt up to the brake spacer plate when fitted.

Align the splines and oil feed holes in the friction disc's and insert the sun gear through the disc's, ensure it engages fully into the differential.

Refit the brake spacer plate locating over the dowels in the walls of the case. Install the annulus gear ensuring it is aligned squarely with the case and dowels. Refit the planet carrier engaging the teeth with both the annulus and sun gear.

Refit the axle arm as described in section D.

Remove the combined filler/level plug and top up the axle oil.

Section F

SETTING PROCEDURE CROWNWHEEL & PINION

Setting up the Crownwheel and Pinion

Section F

A) When a new Spiral bevel Pinion is fitted.

Note the mounting distance "M D" stamped on the front faces of the old and new bevel pinion's.

The shim thickness used with old pinion which is placed between the head of the pinion and the front bearing race must be adjusted to suit the pinion as follows:-

- 1) If the new "MD" is less than the old one increase the thickness of the shim pack by the difference.
- 2) If the new "MD" is more than the old one decrease the thickness of the shim pack by the same amount.

Assemble the pinion into the housing and preload the bearings as described in Section A.

B) When old "MD" is not available or a New Pinion Housing is fitted.

Fit the front (inner) bearing assembly into the pinion housing and sit the assembly on a flat inspection surface, bearing down, apply a downward force to the housing directly above the bearing whilst rotating the housing to ensure that the bearing is correctly seated.

Accurately measure the distance between the inspection surface and the underside of the pinion housing mounting flange i.e. mating surface. This is dimension "A".

Add this dimension "A" to the dimension "MD" stamped on the front face of the pinion and subtract the total from the constant 98.67, the remainder is the shim thickness required.

Assemble the pinion as described in Section "A" and preload the bearings.

With the crownwheel and differential assembled into the centre case as described in Section "B" fit the assembled pre-loaded pinion housing assembly on to the case retaining with two set screws.

Tighten the differential bearing ring nuts to take up any end float in the bearings and lightly preload the bearings. Continue to adjust the ring nuts until the correct backlash is obtained between the teeth on the crownwheel and pinions.

1310 Hardy Spicer 4 bolt flange 0.22-0.30mm

The backlash is best checked via a dial gauge indicator clock located against a drive flange hole or located against the head of a nut and bolt which is secured in one of the holes within the flange.

Equally tighten both ring nuts by the same amount to give the correct bearing preload (it is important that the correct backlash is maintained). The preload is measured by winding a length of string round the pinion flange and measuring the load required to turn

the flange with a spring balance. The preload for the differential bearings must be added to the preload figures obtained for the pinion bearings in section "A".

Additional Differential Bearing Preload	New Bearings	Old Bearings
	1.0-2.0KG (2.20-4.4lbs)	0.5-1.0KG (1.10-2.20lbs)

After setting the preload for the differential bearings recheck the crownwheel/pinion backlash.

Remove the pinion housing and brush some "Engineers Blue" onto a few crownwheel teeth and refit the pinion housing. Rotate the pinion flange a few complete rotations in both directions and remove the housing. Examine the contact markings on both flanks of the crownwheel teeth and compare the markings to the illustrations in section "G" or the original factory markings.

If the marking is different, refer to the notes in Section "G" Spiral Bevel Tooth Contact and make the necessary adjustments.

Secure the adjusting ring nuts with the locking devices and reassemble the remainder of the axle as described in Sections A, C, D, and E.

Remove the combined filler/level plug and top up the axle with oil.

Section G

SPIRAL BEVEL GEAR TOOTH CONTACT

Spiral Bevel Gear Tooth Contact

Section G

The illustration shown below is intended as a reminder to those who are unfamiliar with the terminology applied to Spiral Bevel Gear Teeth

Convex Flank

Concave Flank

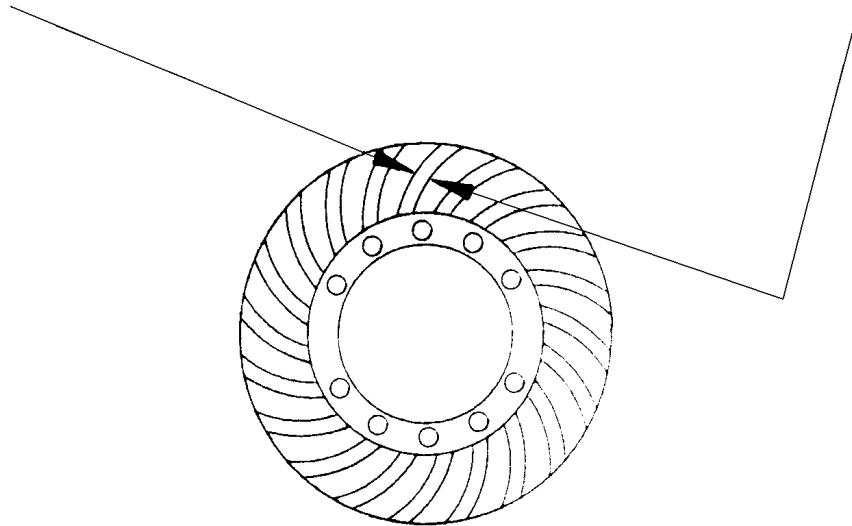

The markings on a crownwheel which is correctly meshed with the pinion should resemble those shown on the illustration below:-

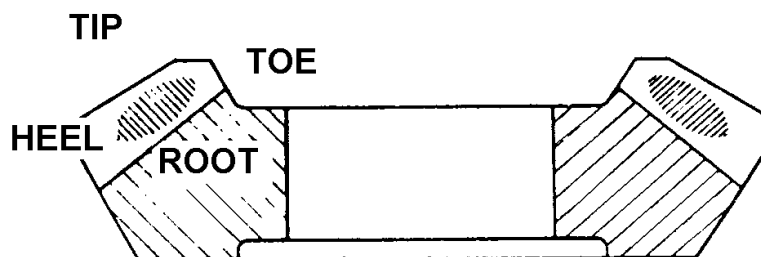

Although the contact point on both flanks of the teeth may vary slightly, generally speaking when correctly setup the markings on both the convex and concave flanks will be in the centre of the tooth form and can still be considered to be correct if, on both flanks, the markings are towards the toe or if crossed slightly e.g. towards the toe on the convex flank and the heel on the concave flank or vice-versa.

If when comparing the contact markings they appear similar to the illustrations below the corrective action indicated is required.

Pinion Too Far Out of Mesh

Convex Flank

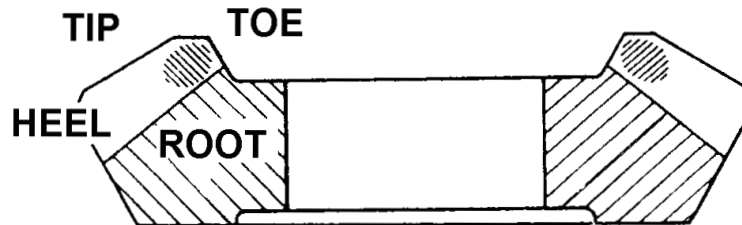

Contact markings closer to toe and tip than factory markings

Concave Flank

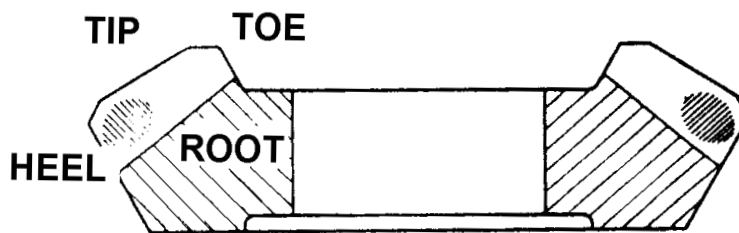

Contact markings closer to heel and tip than factory markings.

Remedy:-

- 175 series Re-check and increase shims behind head of pinion.
- 200 series Re-check and increase shims behind head of pinion.
- 210 series Re-check and increase shims behind head of pinion.
- 220 series Re-check and increase shims behind head of pinion.
- 360 series Re-check and increase shims behind pinion front bearing cone.
- 410 series Re-check and decrease shims between pinion cartridge and axle case.

Pinion Too Far into Mesh

Convex Flank

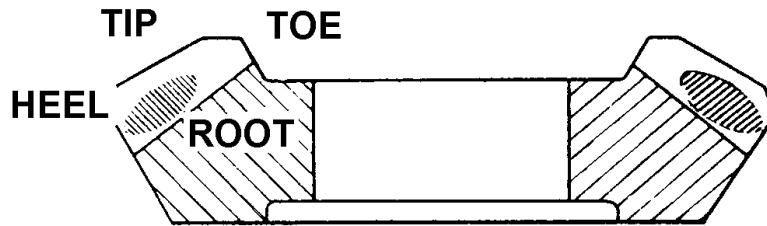

Contact markings closer to heel and root than factory markings

Concave Flank

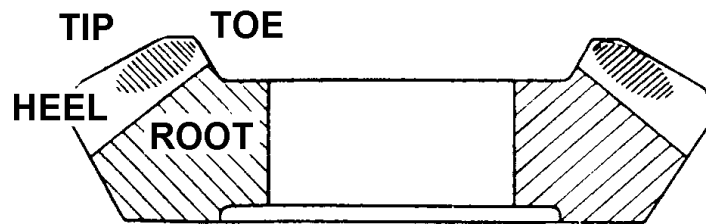

Contact markings closer to toe and root than factory markings.

Remedy:-

- 175 series Re-check and decrease shims behind head of pinion.
- 200 series Re-check and decrease shims behind head of pinion.
- 210 series Re-check and decrease shims behind head of pinion.
- 220 series Re-check and decrease shims behind head of pinion.
- 360 series Re-check and decrease shims behind pinion front bearing cone.
- 410 series Re-check and increase shims between pinion cartridge and axle case.