

WINGET

OPERATION, MAINTENANCE & SPARE PARTS

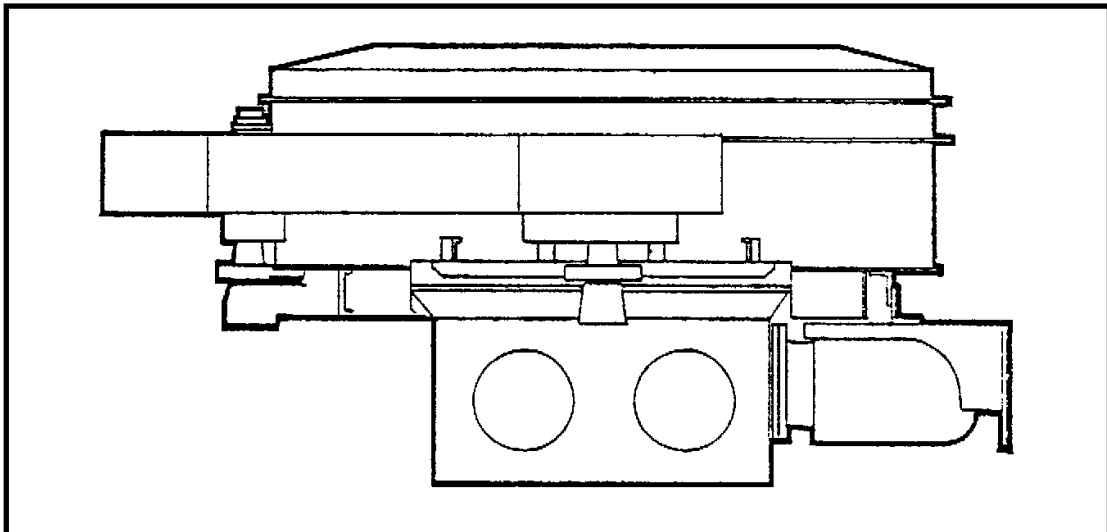

350P2 TURBOMIXER

PRINTED NOVEMBER 1979 REPRINTED
APRIL 2003

WINGET LIMITED
PO BOX 41
EDGEFOLD INDUSTRIAL ESTATE
PLODDER LANE
BOLTON
LANCS
BL4 OLS

TEL: ++ 44 (0) 1204 854650
FAX: ++ 44 (0) 1204 854663
service@winget.co.uk
parts@winget.co.uk
www.winget.co.uk

WINGET

TURBOMIXER

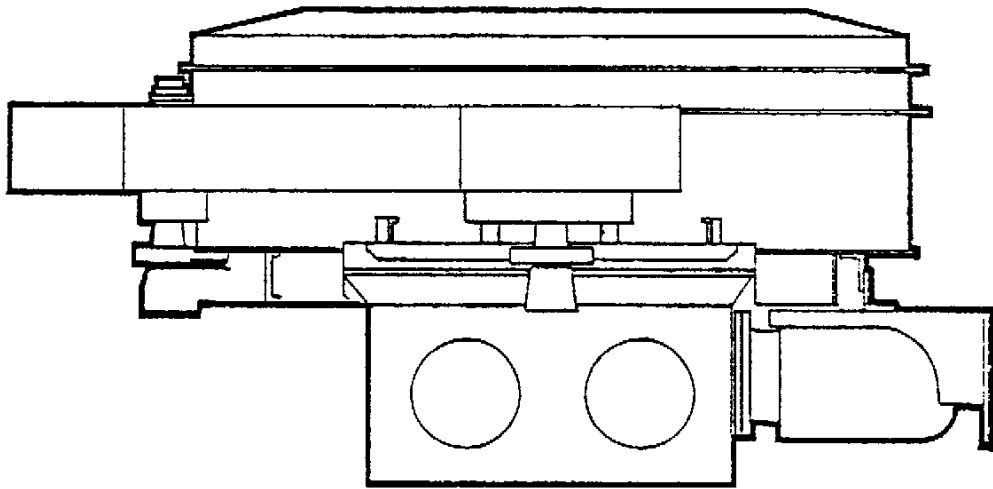

350P2

This manual is a reprint of the Winget publication No S130 last printed during November 1979 and contains some amended part numbers.

Winget Limited operate a policy of continuous product development. Therefore, some illustrations or text within this publication may differ from your machine. The contents of this manual although correct at the time of publication, may be subject to alteration by the manufacturers without notice and Winget Limited can accept no responsibility for any errors or omissions contained within the following pages. Nor can we accept any liability whatsoever arising from the use of this manual howsoever caused.

CONTENTS

Section	Page	Section	Page
INTRODUCTION		TECHNICAL INFORMATION	
Introduction	III	Specification	5.1
Warranty	IV	Dimensions	5.2
SAFE WORKING		PARTS	6.1
Safe Working	1.1	Spares Groups	6.2
Permit to work systems	1.2		
INSTALLATION			
General	2.1		
Air Operated Discharge Doors	2.1		
Pre-running checks	2.1		
OPERATION			
Mixing	3.1		
Discharging	3.1		
Discharge Door	3.2		
Turbo Mixer Covers			
Trapped Key Interlock System	3.3		
Cleaning the Mixer	3.4		
OVERHAUL & MAINTENANCE INSTRUCTIONS			
Lubrication	4.1		
Gear Box Topping Up	4.1		
Oil Change	4.1		
Air Operated Discharge Door	4.1		
Adjustment of Mixer & Scraper			
Blades	4.2		
Pre-loading of Mixer Arm Springs	4.2		
Fitting New Blades	4.3		
Replacement of Wearing Plates	4.3		
Rotor Gearbox & Motor			
Replacement	4.4		
Discharge Door Cylinder			
Maintenance	4.5		
Service Schedule	4.6		

THE HANDBOOK

WARNING *The operator must read all the Handbook and fully understand its contents before attempting to operate the machine.*

THE HANDBOOK MUST BE AVAILABLE TO THE OPERATOR AT ALL TIMES.

The Handbook must be kept clean and in good condition. Additional copies of the Handbook can be obtained from Winget Limited.

The contents of this Operator's Handbook are designed as a guide to the machine's controls, operation, working capacities and maintenance. It is **not** a training manual.

Only trained operators should use this machine. Contact the C.I.T.B. or equivalent body for advice on training.

The operating instructions and maintenance recommendations contained in this book will enable you to become familiar with your mixer to obtain the best results in the shortest possible time.

The life and trouble free running of your machine will depend largely on the care it receives. It is your responsibility to ensure that the maintenance instructions outlined in this book are carried out.

When replacements are required, it is essential that only genuine Winget parts are used and that any repair or servicing work is carried out by competent fitters.

In this Handbook are **WARNING** notes. They are preceded by this symbol:

**WARNING**

*These notes are used to indicate the procedure being described in the Handbook must be followed to avoid serious injury or death to yourself or to others; or damage to the machine.
The warnings are also used to protect the machine from unsafe servicing practices.*

Pay particular attention to the warnings given in the Handbook.

If you have any doubts about any aspect of the machine's capability or servicing procedures, you must consult the manufacturer.

WARRANTY

As every reasonable care is taken that goods of this Company's manufacture shall be free from defect in material and workmanship, the Company will supply free to any destination in the British Isles named in the tender or F.O.B. British Ports in the case of goods situated abroad, any part or parts which, under normal service, appears to the Company's satisfaction to have been at the time of delivery defect in such parts, provided it is notified thereof within twelve months or 2,000 working hours from the date of delivery (whichever shall be the earlier) or, where the Company is responsible for erection, within twelve months from the date on which the customer is notified that any plant or machinery is ready for starting up provided that:-

- a) Written notice is given to the Company within seven days of the discovery of the defect.
- b) Unless otherwise agreed, the alleged defective part or parts are returned to the Company's Works carriage paid and its inspection establishes the claim. Replaced parts shall become the property of the Company.
- c) No part which is not of the Company's manufacture has been fitted, otherwise than by it or on its behalf, or with its written approval.
- d) No unauthorised alteration or modification has been made to the machine or component the subject of the claim.

In no cases shall the Company be responsible for the cost of fitting replacement parts.

Machines parts or components sold by the Company but not of its manufacture are subject only to such warranty (whether expressed or implied by law) as is given by the makers thereof and are not covered by this Guarantee. The Company will as far as is practicable make available to the purchaser the benefit of any warranty given to the Company by the makers of such machines or components.

This Guarantee and/or warranty is personal to the Company's customer and may not be assigned.

Any other warranty or condition expressed or implied by law and whether statutory or otherwise is hereby excluded as is also any claim based on any verbal or other representation or conditions made in relation to any goods the subject of any offer or tender submitted by the Company unless confirmed in writing by a Director of the Company.

Save as aforesaid the Company shall not be responsible for any loss or injury or damage however caused or arising.

Safety is the responsibility of the persons working with this machine. Think "safety" at all times. *Read and remember the contents of this Handbook.*

MACHINE MODIFICATION

WARNING Any modifications to the machine will affect its working parameters and safety factors. Refer to the Manufacturers before fitting any non-standard equipment or parts.



The manufacturers accept no responsibility for any modifications made after the machine has left the factory, unless previously agreed by the Manufacturers in writing. The Manufacturers will accept no liability for damage to property, personnel or the machine if failure is brought about due to such modifications, or fitment of spurious parts.

IMPORTANT

Your TURBOMIXER is a high speed Mixer.

The mix should never be allowed to remain in the Pan for a period in excess of twice the mixing time required for any particular mix, otherwise, heavy overloading of the gearbox will result.

Average mixing times are given on Page 3.1 of this book.

Recourse to a wet Hopper should be arranged if the take-off from the plant is erratic.

WARNING



Under no circumstances should the Mixer be stopped and re-started during the mixing cycle.

Purchasers are advised to familiarise themselves with the requirements of Paras. 38 to 42 of the "Advisory Code on Safety in Batching Plants" when fitting mixers to plants.

NOTE: When a mixer is supplied as a part of a Batching Plant, the safety arrangements will probably differ from those indicated in this Manual. Check that you understand the safety arrangements of the Manual provided with the Batching Plant before carrying out any maintenance.

PERMIT TO WORK SYSTEMS - PARAGRAPH 53 (BS/5304)53.1 Circumstances of Use

Interlocking guards (see clause II) and safety devices provided at small units of machinery for the protection of the Operator also protects the maintenance man when he requires access to the danger area. At larger machinery and process plant however, this protection may not be available to Maintenance Personnel who, having entered a danger area, may be out of sight and therefore exposed to danger if the plant is switched on.

In these circumstances it is necessary for management to identify the hazards which are exposed and to develop a safe system of work whereby these hazards are eliminated or as a last resort, recognised by the employee(s) so that personal precautions against possible injury can be taken. Oral instructions, requests or promises are liable to be misheard, misinterpreted or forgotten and are therefore, not a satisfactory basis for action of which men's lives may depend. The unsatisfactory working of such procedures has been proved time and again.

53.2 A written System

Effective control should be achieved by means of a written system, though even this relies on the human element, for no documentary system can by itself prevent accidents. The system, which is known as a permit to work system, requires formal action on the part of those doing the work, those responsible for it and those authorised to sign such permits.

53.3 Contents

- a) Such a permit should clearly set for management, employees and other persons, for example, outside contractors
- b) The work to be done.
- c) Who will supervise the work.
- d) Who is to carry out each section of the work.
- e) The safety precautions which have been taken.
- f) The precautions which still need to be taken by the employee before commencing work, for example, affixing physical locking devices and danger boards.
- g) A time limit (if necessary) within which a check needs to be carried out to see if the working environment is still safe.
- h) The procedure that should be followed before the permit to work is cancelled.

The person responsible for undertaking the work should sign a statement signifying that he understands the task and the precautions to be taken.

53.4 Advantages

A safe procedure is therefore specified forming a clear record of all the foreseeable hazards which have been considered in advance, together with the appropriate precautions taken in their correct sequence. Adequate supervision to see that the system operates properly is required.

Work in potentially hazardous circumstances can be done in safety by the use of this method and the confidence of employees can be gained. The design of a permit to work will depend on the nature and degree of risk, the complexity of the task and the industry to which it relates.

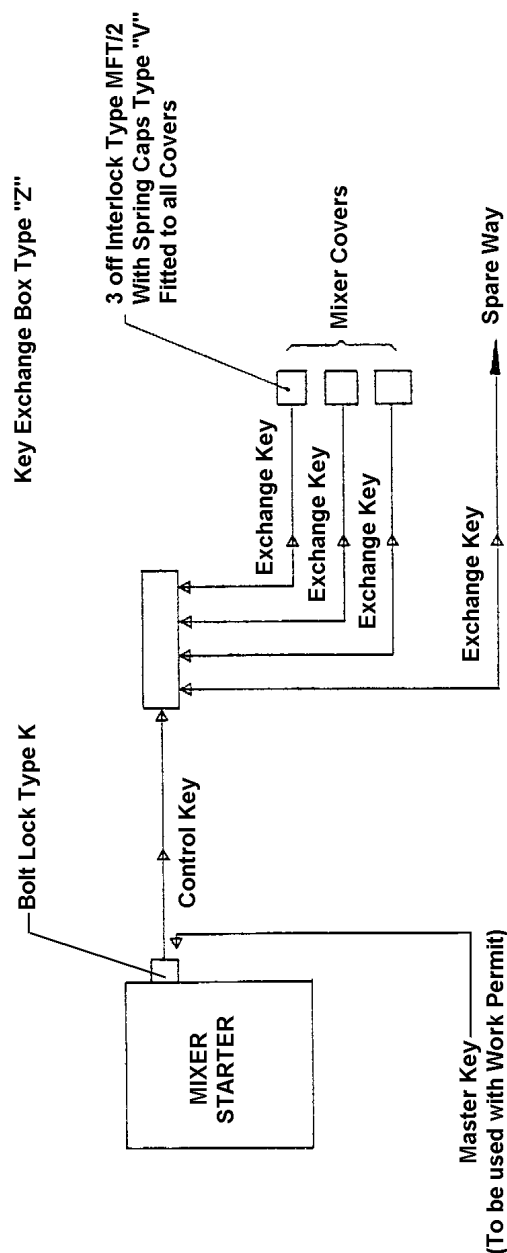

INSTALLATION

General

The Mixer must be installed in its working position ensuring that it is mounted horizontally, and that there is no distortion of the base frame. Provision should be made below the Mixer to allow a free circulation of cooling air in and around the electric drive motor.



Access to the discharge door(s) from the underside of the Mixer is recommended for inspection and maintenance of the mixing blades, subject to the recommendation of Paras. 38 to 42 of the Advisory Code on Safety in Batching Plants.

Air Operated Discharge Door(s)

The standard discharge door is operated by an air cylinder. The working pressure required is in the range of 5.52 to 6.9 Bar (80 to 100 p.s.i.) but should not exceed 10.3 Bar (150 p.s.i.). The air supply is first passed through a filter to remove any dirt or moisture present, and then through an atomizing type airline lubricator.

If doors are hand, hydraulic or electrically operated, separate information is provided.

PRE-RUNNING CHECKS

Check the level of oil in Gearbox, top up as necessary. See pages 4.1 and 4.4 for instructions.

Check 1.6mm (1/16") clearance between blades and pan, adjust as necessary. See Page 4.2.

If the Mixer is being used for the first time after the electrical circuit has been connected or re-connected, ensure correct rotation of mixing blades.

If the water system has been drained, re-connect supply and pass a quantity of water through flowmeter to ensure accurate operation.

Check that safety arrangements are fitted, that you understand the method of operation and that they are in working order.

OPERATIONMixing

It is important that the mixing blades are rotating at their full working speed before any material is fed into the pan.

It is recommended that to reduce the mixing time cycle to a minimum where possible, the cement, water and aggregate be added to the pan simultaneously.

Mixing time will vary depending on the type of mix, but should NEVER be less than thirty seconds, the average time being thirty to forty-five seconds.



NOTE: The mix should never be allowed to remain in the pan after mixing time has expired.

The action of the mixing blades and aggregate generates a small amount of heat, which will cause the water content to drop and consequently stiffen the mix. This stiffening would eventually reach a point when it would cause the over-load trip mechanism of the starter switch to operate and stall the Mixer.

In the event of the Mixer stalling, the discharge door(s) should be opened, water added to the mix and as much concrete as possible shovelled out before any attempt is made to restart the electric motor.

With the trapped key interlock system supplied with the mixer used, as instructed, it is impossible for the mixer to be started while the above operation is in progress. This will also apply when the mixer is supplied as an integral part of a batching plant fitted with a trapped key interlock system.



WHERE THE PURCHASER HAS AGREED TO PROVIDE SAFETY ARRANGEMENTS, IT IS ESSENTIAL THAT THEY DO NOT ALLOW THE MIXER TO BE STARTED WHILE THE CLEARING OPERATION IS IN PROGRESS.

Discharging

An air operated semi-circular shaped discharge door(s) in the bottom of the mixing pan, allows the concrete to be quickly discharged by the action of the rotating mixing blades.



It is recommended that on a Mixer fitted with two or more discharge Doors, that if only one is consistently used for any period, to prevent the unused door(s) from sticking, that it/they be opened after approximately every ten batches, to remove any grout that will have accumulated in the crevice between the door and the pan.

Cleaning the Mixer

See Page 3.4

TURBO MIXER COVERS

Grouping No _____

Trapped Key Interlock System

The standard Mixer is supplied complete with covers and starter, protected by a trapped key interlock system, see page 1.3. Mixers may also be supplied:-

- a) Less Starter
- b) With Starter but less trapped key interlock on Starter
- c) Less Covers
- d) With Covers but less trapped key interlocks
- e) Combination of items a - d

Winget Limited will not accept responsibility for the safe working of a Mixer supplied as items a - e. Mixers are in fact supplied as items a - e but only on a written undertaking by the purchaser to take specified steps sufficient to ensure that the machine is safe and without risks to health when properly used.

Mixer sizes 333P2 to 750P2 - These are protected by interlocks as indicated on flow diagram 506740500. This comprises a bolt lock type K, with control key fitted to the starter, a key exchange box with four keys, three locks type MFT2 fitted to the three openings in the mixer covers, and a master key recognised by the 'T' shaped handle.

In the normal working condition, the control key is in the operated position in the starter, and the isolator turned to the 'ON' position. The mixer covers are in the closed position with the locks secured and four keys are in the exchange box. In this condition all keys are trapped and cannot be removed from the bolt lock 'K'. If the key is inserted in the key exchange box and turned, the four keys are freed, and may be removed, but the control key is trapped in the box, making it impossible to start the mixer while the four keys are not in position in the exchange box.

Three of the keys are used for operating the locks type MFT2 fitted to the Mixer openings. When operated to release the locks, the keys are trapped in the locks. A locating arrangement is fitted to the removable top cover to ensure that the lock cannot be operated with cover detached.

The fourth key is not required for opening the mixer covers, but is supplied so that a further chain of interlocks may be initiated if so required.

Each set of keys is specific to the mixer for which it is supplied. Any queries or spares requirement should be accompanied by the Grouping Number indicated under the title of this section of the Manual.



The master key **MUST** be kept in the possession of a person in authority. It is provided to enable the mixer to be run with the covers open, to check adjustments. **IT IS TO BE ISSUED BY THE PERSON IN AUTHORITY, ONLY WITH A 'PERMIT TO WORK SYSTEM'**. The requirements of a 'Permit to Work System' are indicated under the "Safe Working" section. See page 1.2

When the mixer is supplied with a plant, a different interlock system may be fitted and it is **IMPERATIVE** to be familiar with the arrangements fitted, which will be described in the plant manual.

Mixer Sizes 1000P2 to 2000P2 - These are protected by an interlock system as indicated on the Flow Diagram (506740600). The system works in exactly the same way as that for the smaller mixers, with the exception that there are five openings in the mixer covers, instead of three, and the key exchange box is fitted with six trapped keys.

CLEANING THE MIXER

Remember, a clean mixer is more efficient, reducing considerably the wear on the pan and mixing elements.

At the end of each day's work, or if the mixer is idle for a period of more than one hour, the mixer should be thoroughly washed to prevent concrete setting in the pan or on the mixing elements.

Initial cleaning can be carried out by introducing a quantity of gravel and water and running the mixer for three to four minutes. This will not clean the mixer completely.

Utilizing the trapped key interlock system, open the covers and hose down with a high pressure hose. Close the covers and, using the trapped key arrangements, restart the mixer, run for a few minutes and discharge. A gradual build-up of set concrete may occur after extended use, and a man may have to enter the mixer pan to chip off the build-up.

Using the trapped key system, as described, backed up by a 'Permit to Work' arrangement, the man will be safe, but **ENSURE THAT THE MASTER KEY IS WITH THE PERSON IN AUTHORITY**. If the mixer is supplied as part of a plant, a different interlock system may be fitted - **ENSURE THAT THIS IS UNDERSTOOD BEFORE ALLOWING A MAN TO ENTER THE MIXER**.



These instructions apply only to safety arrangements supplied by Winget. Where customers have contracted to supply their own safety arrangements, **THE PERSON IN AUTHORITY MUST CHECK THE SAFETY ARRANGEMENTS ACTUALLY FITTED BEFORE ANY WORK IS CARRIED OUT ON THE MIXER**.

Coating the interior of the mixer with mould oil will reduce concrete build-up.

ADJUSTING BLADES AND MAINTENANCE

This must be carried out using the trapped key system together with a 'Permit to Work' system. In checking blade clearances it is necessary to rotate the rotor slowly. Due to the drive arrangements this can be achieved only by a momentary operation of the starter. Since the covers will be open, and the master key is required to override the trapped key system **THIS IS A DANGEROUS OPERATION**. IT IS THE CUSTOMER'S RESPONSIBILITY TO ENSURE THAT THE DANGERS ARE HIGHLIGHTED IN THE 'PERMIT TO WORK' DOCUMENT.



4.1

OVERHAUL & MAINTENANCE INSTRUCTIONS



WARNING: BEFORE ANY MAINTENANCE WORK IS CARRIED OUT, ENSURE THAT THE TRAPPED KEY INTERLOCK IS FULLY UNDERSTOOD, AND WHETHER IT APPLIES TO THE MIXER ONLY, OR THE COMPLETE PLANT IF MIXER IS SUPPLIED IN A PLANT. ENSURE THAT A 'PERMIT TO WORK' SYSTEM IS PROVIDED AND UNDERSTOOD.

IF THE MIXER HAS BEEN SUPPLIED AS ITEMS A TO E (PAGE 3.3) IT IS THE CUSTOMER'S RESPONSIBILITY TO ENSURE THAT SUITABLE SAFETY ARRANGEMENTS ARE PROVIDED.

LUBRICATION

WORM GEARBOX - Topping Up

The oil level should be checked at weekly intervals with the oil COLD by removing the filler cap situated underneath the mixer pan adjacent to the drive motor. If necessary, top up with one of the recommended oils to the level of the end of the filler tube.

Oil Change

Oil in the Worm Gearbox should be changed after the first months running and subsequently every six months. This is best carried out at the end of a day's working with the machine stationary when the oil is warm, but allowing enough time for the oil to settle.

1. Remove the breather plug from the elbow on the side of the gearbox. Remove drain plug from the tee piece on the bottom of the gear case and collect the oil in a suitable container. Capacity 21 litres, 37 pints. Dispose of waste oil in accordance with local regulations.
2. Refill with TOTAL CIRKAN C460 or SHELL VITREA 79 or equivalent to the level of the end of the filler tube. Note: do not mix oils from different suppliers. Clean breather holes in breather plug and refit to elbow on side of gearbox.

Rotor Shaft and Worm Gearbox Top Bearings

Grease nipples for these are provided at the motor end of the mixer subframe and require lubrication at weekly intervals.

Air Operated Discharge Door

Two grease nipples provided requiring lubrication at weekly intervals. Oil level in air line lubricator should be checked daily.

Recommended oils are as follows:-

TOTAL	Azzola ZS22
SHELL	Tellus 21
ESSO	Norpol 35
CALTEX	Caltex Spinde Oil A
MOBIL	Mobil Velocite No. 6

NOTE: See Page 4.6 for Lubrication and Servicing Schedule

4.2 OVERHAUL & MAINTENANCE INSTRUCTIONS

ADJUSTMENT OF MIXING AND SCRAPER BLADES

The blades should be inspected daily for wear and adjusted if necessary to give approximately 1.6mm (1/6") clearance between the blades and the tightest spot on the circumference of the pan and the pan bottom.

This should be carried out by slackening the blade bolts and repositioning the blades on the slotted holes provided. Access to the mixing blade bolts is best achieved by positioning the blade over the door opening.

After any adjustments have been made, it is recommended that the rotor be rotated slowly to ensure all-round clearance of the blades to allow for any possible distortion of the pan.

NOTE: It is not possible to rotate the rotor by hand and it will be necessary to momentarily operate the mixer starter to give partial rotation of the rotor.

Alternatively remove the motor fan cowl and turn the fan by hand.

Pre-loading of Mixing Arm Springs

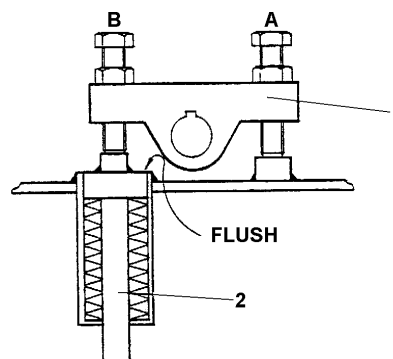

1. Remove the cover plate from the top of the rotor.
2. Slacken blade bolts and raise the blade on the slotted holes as far as possible.
3. Slacken locknuts on Screws A and B.
4. Adjust Screw A so that the top of the rocker (Ref. 1) is horizontal.
5. Adjust Screw B so that the top of the collar on the shock absorber pin (Ref. 2) is flush with the top of the tube welded into the rotor base plate.
6. Tighten both locknuts and replace rotor cover plate.
7. Re-adjust blade to 1.6mm (1/16") clear of the pan bottom and side.

NOTE: These screws should not be used for blade height adjustment.

4.3 OVERHAUL & MAINTENANCE INSTRUCTIONS

FITTING NEW BLADES

Badly worn blades should be removed as follows:-

Open the discharge door and position the worn blade over the door opening. (See note regarding rotation of rotor).

Detach the blade by removing the two fixing bolts securing it to the blade arm.

Fit new blade and set to correct clearance from pan bottom. Rotate rotor slowly as previously described to check clearance all round pan.

REPLACEMENT OF WEARING PLATES

To assist in the replacement of wearing plates, they have been divided into easily removable sections. After any plates have been replaced, it is recommended that the rotor be turned slowly to ensure correct adjustment of blades. (See Note).



IMPORTANT NOTE: REMOVAL OF THE PAN COVER CANCELS THE SAFETY ARRANGEMENTS. ENSURE THAT THE FOLLOWING WORK IS CARRIED OUT USING A 'PERMIT TO WORK'. ENSURE ALSO THAT THE ISOLATOR IS SWITCHED OFF, THAT THE TRAPPED KEY THUS FREED IS RETAINED ON HIS PERSON BY THE MAN CARRYING OUT THE REPLACEMENTS, AND THAT THE FUSES ARE REMOVED. CHECK THAT THE OVERRIDE KEY IS IN THE POSSESSION OF THE RESPONSIBLE PERSON ISSUING THE PERMIT TO WORK.

THE ABOVE APPLIES TO THE STANDARD SAFETY ARRANGEMENTS PROVIDED. CHECK SAFETY ARRANGEMENTS IF MIXER IS SUPPLIED AS PART OF PLANT, OR IF SAFETY ARRANGEMENTS WERE NOT SUPPLIED BY WINGET.

Bottom and Inner Plates

1. Remove pan cover to expose mixing blades.
2. Detach one mixing arm by removing the two bolts, which secure it to its pivot shaft.
3. Rotate rotor so that the remaining arms and blades are clear of the wearing plate segment to be removed.
4. Remove the countersunk screws and lift the wearing plate from the pan.
5. Fit new wearing plate, assembly mixing arm and top cover.

4.4 OVERHAUL & MAINTENANCE INSTRUCTIONS

Outer Wearing Plate

1. Remove pan cover to expose mixing blades.
2. Rotate rotor until outer blade arms are clear of segment to be replaced.
3. Remove the countersunk fixing bolts and lift wearing plate from pan.
4. Fit new wearing plate, assembly mixing arm and top cover.

ROTOR, GEARBOX AND MOTOR REPLACEMENT

The notes given in this section are intended for general guidance only.

1. Disconnect the electrical supply from the mixer by removing the fuses and the electrical connections at the motor. These should be clearly labelled to assist in easy reconnection.
2. Drain the oil from the Gearbox into a suitable clean container and detach the filling tube and bracket. Dispose of waste oil in accordance with local regulations.
3. Remove pan cover and rotor cover plate to obtain access to the six nuts securing the rotor and lift off rotor complete with arms if headroom available or detach blade arms if not.
4. Remove two bolts securing plate from top of rotor shaft and screw in lifting eye.
5. Attach suitable lifting tackle and take weight of the box.
6. Remove the six bolts securing the worm gearbox and bell housing to the pan bottom and the two bolts in the motor steady bracket and lower the assembly from the pan.
7. If necessary the motor may be removed from the worm gearbox separately by removing the four bolts in the motor flange and the two bolts in the steady bracket without draining the worm gearbox.

To refit the gearbox and motor carry out reverse procedure to above, finally refilling the gearbox with oil to correct level. See Page 4.1 for recommended oil and capacity.

Remake electrical connections and check direction of rotor rotation.

Check blade clearances as on Page 4.2.

Replace pan covers before using the mixer.

4.5

OVERHAUL & MAINTENANCE INSTRUCTIONS

AIR OPERATED DISCHARGE DOOR

Cylinder Maintenance

The air cylinders have been developed to give trouble free maximum cycle performance with minimum maintenance. It is however, essential to exclude moisture, pipe scale and other foreign matter and to ensure that a constant line pressure with effective lubrication is available at the point of application. This can be provided by fitting an air line filter and lubricator in the main air line with the lubricator positioned between the filter and the valve controlling the cylinder.

Under reasonable conditions the seals will last for a long time but when it eventually becomes necessary to replace them it is advisable to use a seal fitting tool for the piston rod seals.

The cylinder end caps should be removed at regular intervals and the piston rod assembly withdrawn, cleaned and inspected. The cylinder, piston rod and seals should be cleaned by washing in white spirit or paraffin. In no circumstances should any form of degreasing fluid be used.

It is advisable to hold the cylinder in a vice so that both hands are free to guide the piston packing passed the leading edge into the cylinder bore. The seals are a major contributing factor to the efficient operation of the cylinder and, therefore, every care should be taken to ensure that they are not damaged during assembly.

4.6**OVERHAUL & MAINTENANCE INSTRUCTIONS**LUBRICATING AND SERVICING SCHEDULE

DAILY or 24 Working Hours	
GENERAL	Thoroughly clean the inside and outside of the Mixer paying particular attention to mixing and scraper blades. Give Mixer a coating of equal parts of paraffin and engine oil. Apply a little engine oil to all moving parts, pin joints on discharge doors etc.
DISCHARGE DOOR	* Use Grease Gun - 2 Nipples
AIRLINE LUBRICATOR	Check Oil Level, See Page 4.1 for recommended Oils.
AIR CYLINDER PIVOT	* Use Grease Gun - 2 Nipples
GEARBOX	Check oil level using filler tube, top up if necessary. Top up with recommended oil only, See Page 4.1. * Use Grease Gun - 2 Nipples
MONTHLY or 800 Working Hours	
ROTOR ARMS	* Use Grease Gun - 5 Nipples
SIX MONTHLY or 5000 Working Hours	
WORM GEARBOX	Change Oil in Gearbox, See Page 4.1

*TOTAL MULTIS 2 or SHELL "ALVANIA" Grease No. 2 or "UNEDO" Grease No. 2

5.1**TECHNICAL INFORMATION**SPECIFICATION

BATCH FEEDING BASED ON 50 BATCHES PER HOUR		
BATCH	Input	500 Litres/18 Cu. Ft
	Output	350 Litres/12 Cu. Ft.
OUTPUT	Cu. M./Hr.	16
	Cu. Yds./Hr.	22
MOTOR	h.p.	20
	r.p.m.	1460
WEIGHT	Kilos	2070
	lbs.	4563.5
NO. OF MIXING BLADES		5
OVERALL DIMENSIONS		
Length	Mm	Ins
D1	1721	67.7
D2	900	35.4
H1	1216	47.9
H2	305	12.0
H3	420	16.5
H4	163	6.4
H5	633	24.9
H6	127	5
L1	1080	42.5
L2	1840	72.4
L3	1320	52.0
L4	1160	45.7
L5	350	13.8
L6	948	37.3
L7	229	9.0
R1	1160	45.7
R2	400	15.7
R3	360	14.2
R4	1325	52.2

WINGET LTD RETAIN THE RIGHT TO ALTER THIS SPECIFICATION WITHOUT NOTICE IN ACCORDANCE WITH OUR POLICY OF CONTINUOUS PRODUCT IMPROVEMENT.

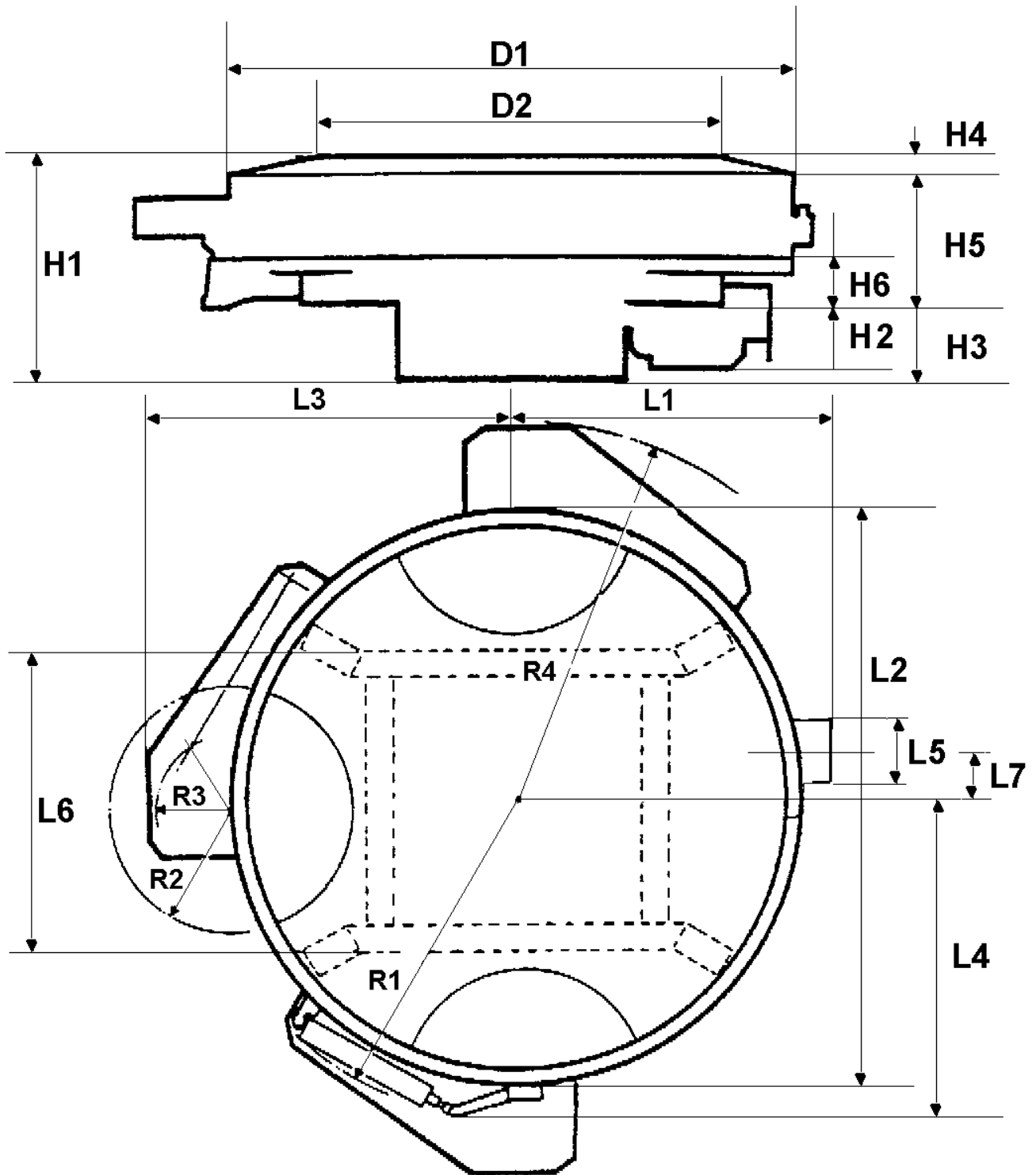

TO FIND A SPARE PART

The assemblies have been divided into groups and given identification letters A, B, C etc. To identify a component, first find the relevant assembly in the list given on Page 6.2, this will give you a group letter to turn to. On turning to this group the illustrations will enable you to identify the part you required and give you a reference number. Against this number in the Parts List will be found the DESCRIPTION AND PART NUMBER information, which we require.

To avoid delays and errors, remember always to quote THE MACHINE NUMBER, which will be found stamped on a plate at the side of the machine.

6.2**SPARE PARTS**SPARES GROUPS

A1	Subframe and Mounting Pedestal Assembly
A2	Mixing Pan and Wear Plates Assembly
A3	Pan Bottom Wear Plates Assembly
A4	Pan Covers Assembly
B1	Rotor and Blades Assembly
B2	Bell Housing Assembly
B3	Worm Gearbox Assembly
C1	Discharge Door Assembly
C2	Door Limit Switch Assembly
C3	Door Cylinder Guard Assembly

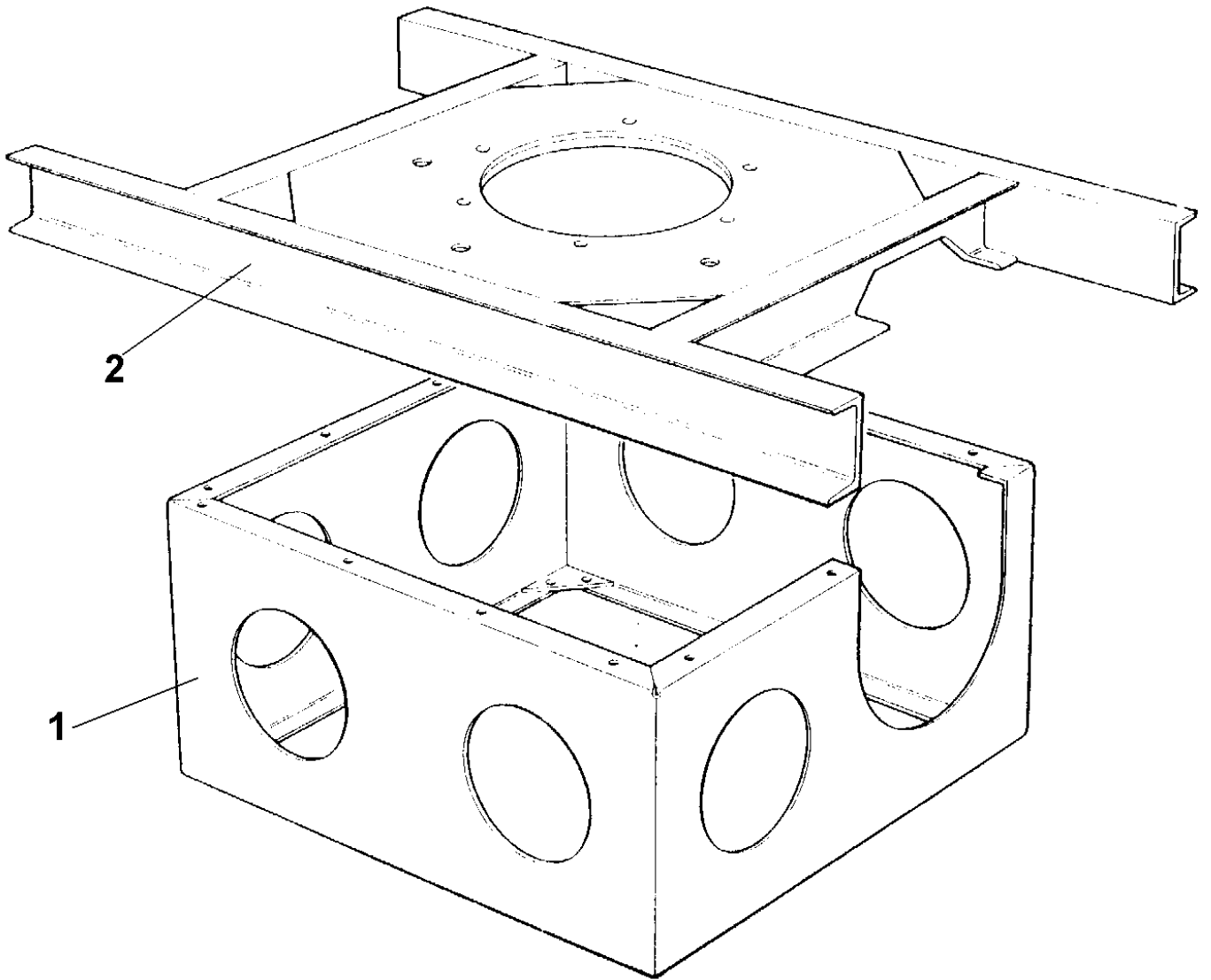

SUBFRAME & MOUNTING PEDESTAL ASSEMBLY

A - 1

Item	Part no	Serial no	Description	Qty
1	514407400		Mounting Pedestal	1
1A	8S05D		Bolt	14
1B	17S05		Washer Spring	14
1C	105S05		Washer Tapered	14
1D	7S05		Nut	14
2	514404800		Sub Frame	1
2A	8S05D		Bolt	20
2B	17S05		Washer Spring	20
2C	105S05		Washer Tapered	20
2D	7S05		Nut	20

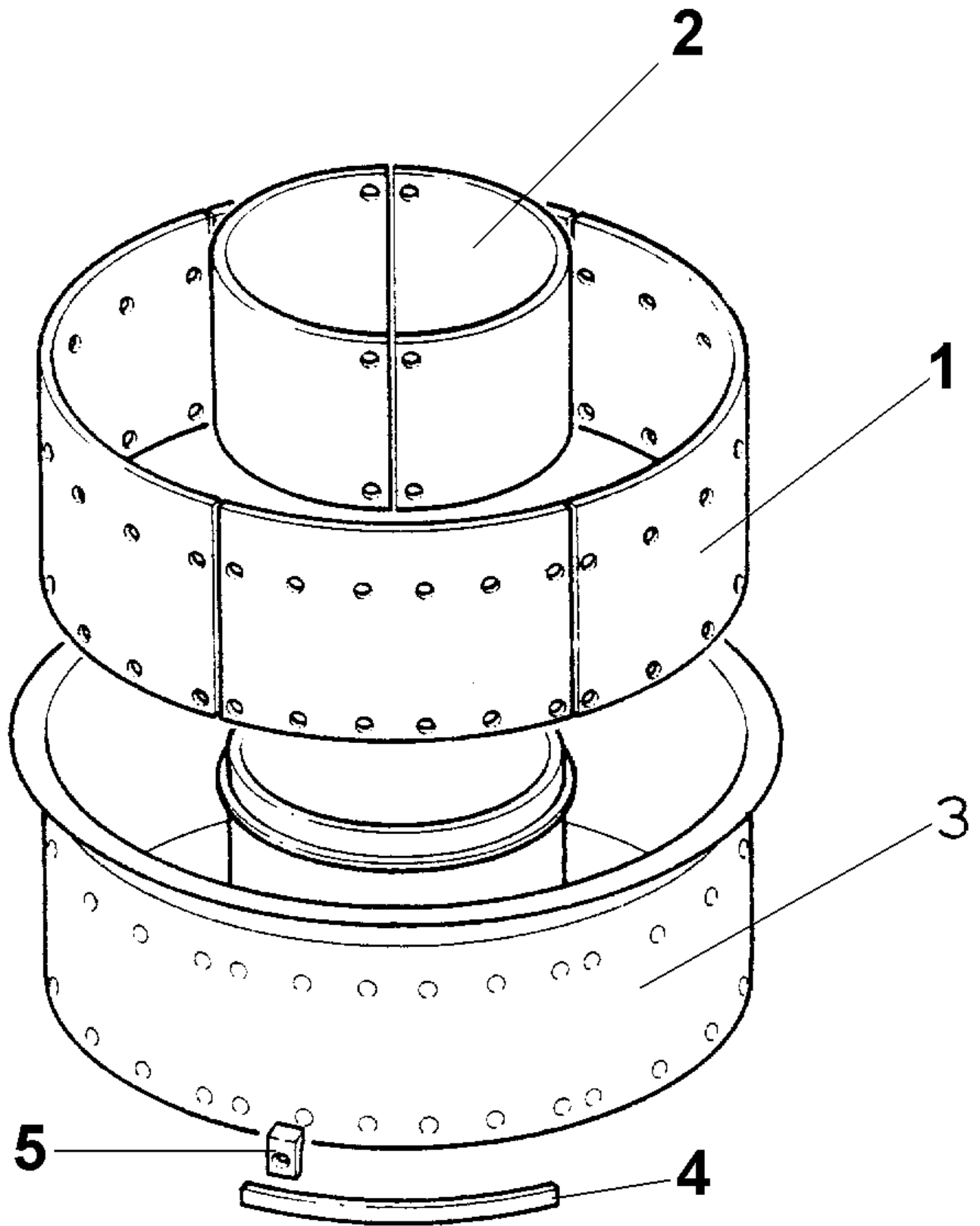

MIXING PAN & RIM WEAR PLATES ASSEMBLY

A - 2

Item	Part no	Serial no	Description	Qty
PAN WITH 1 DOOR				
1	514405000		Outer Wearing Plates	4
1A	52S05K		Screw C'sunk Slit	4
1B	17S06		Washer Spring	4
1C	7S05		Nut	4
1D	52S05F		Screw C'sunk Slit	44
1E	17S06		Washer Spring	44
1F	7S05		Nut	44
2	514405100		Inner Wearing Plate	2
2A	52S05F		Screw C'sunk Slit	12
2B	17S06		Washer Spring	12
2C	7S05		Nut	12
3	514404900		Mixing Pan	1
4	514406400		Door Sealing Strip	1
5	514406300		Sealing Strip Clamp	4
PAN WITH 2 DOORS				
1	514405000		Outer Wearing Plates	4
1A	52S05K		Screw C'sunk Slit	8
1B	17S06		Washer Spring	8
1C	7S05		Nut	8
1D	52S05F		Screw C'sunk Slit	40
1E	17S06		Washer Spring	40
1F	7S05		Nut	40
2	514405100		Inner Wearing Plate	2
2A	52S05F		Screw C'sunk Slit	12
2B	17S06		Washer Spring	12
2C	7S05		Nut	12
3	514404900		Mixing Pan	1
4	514406400		Door Sealing Strip	2
5	514406300		Sealing Strip Clamp	8
PAN WITH 3 DOORS				
1	514405000		Outer Wearing Plates	4
1A	52S05K		Screw C'sunk Slit	12
1B	17S06		Washer Spring	12
1C	7S05		Nut	12
1D	52S05F		Screw C'sunk Slit	36
1E	17S06		Washer Spring	36
1F	7S05		Nut	36
2	514405100		Inner Wearing Plate	2

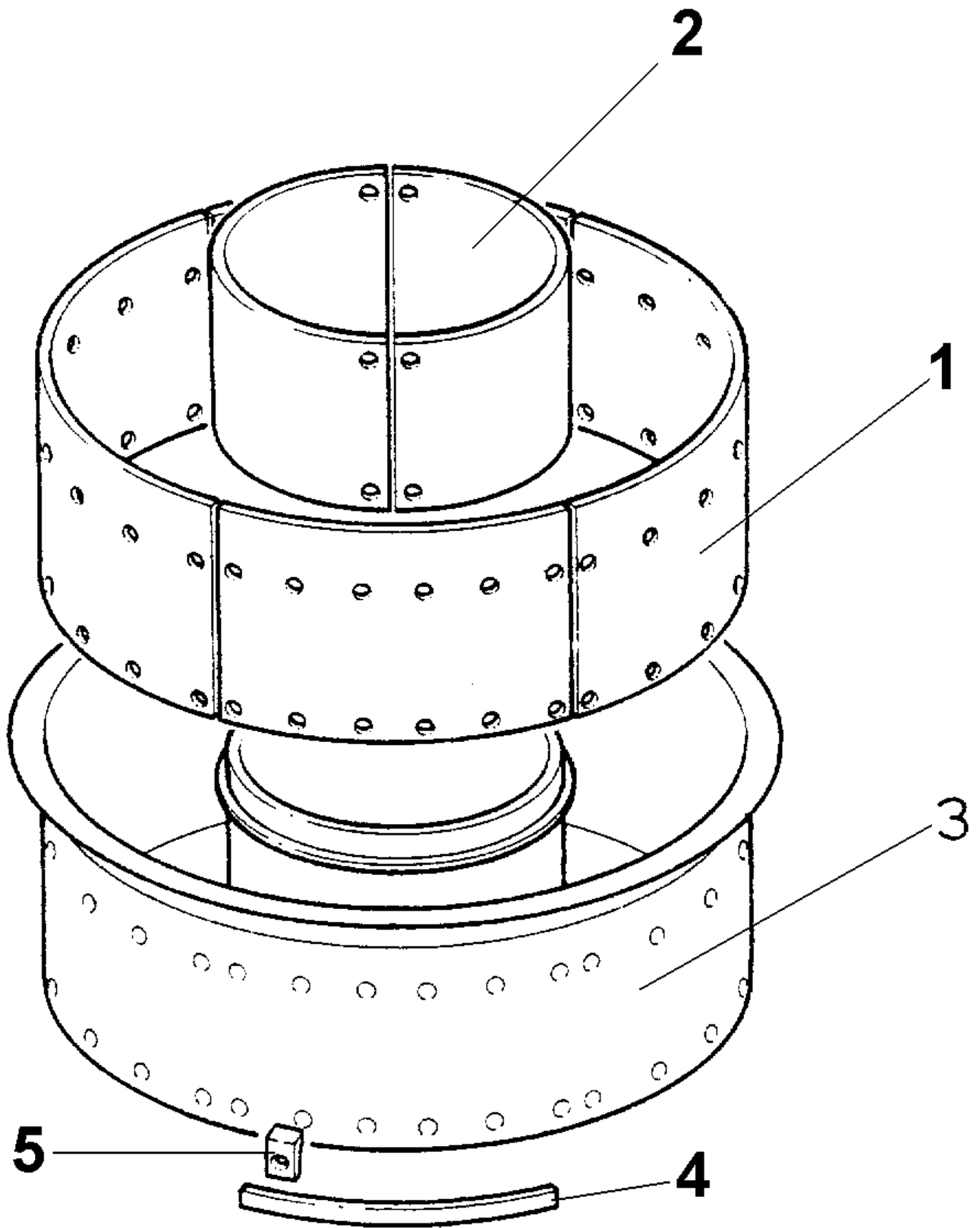

MIXING PAN & RIM WEAR PLATES ASSEMBLY

A - 2

Item	Part no	Serial no	Description	Qty
PAN WITH 3 DOORS, CONTINUED				
2A	52S05F		Screw C'sunk Slit	12
2B	17S06		Washer Spring	12
2C	7S05		Nut	12
3	514404900		Mixing Pan	1
4	514406400		Door Sealing Strip	3
5	514406300		Sealing Strip Clamp	12

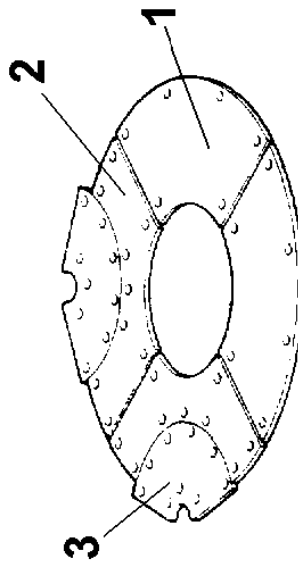
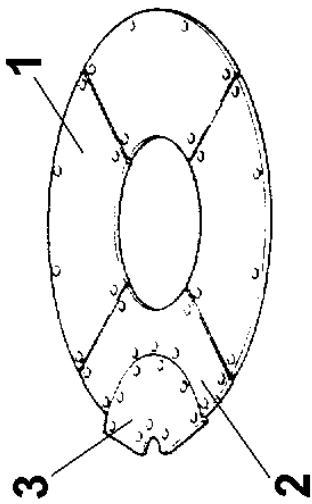
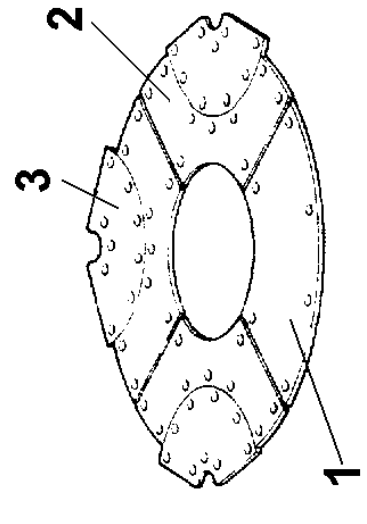
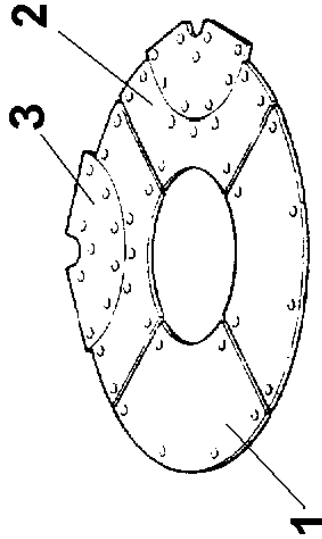
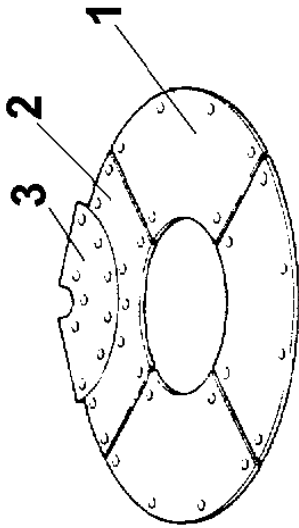
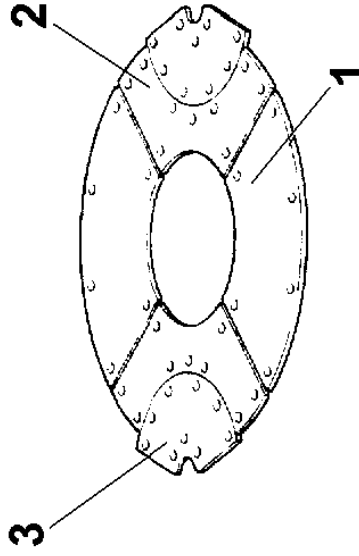
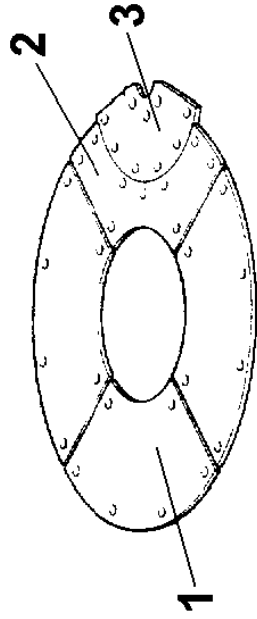

PAN BASE WEAR PLATES ASSEMBLY

A - 3

Item	Part no	Serial no	Description	Qty
PAN WITH 1 DOOR				
1	514406100		Bottom Wear Plate	3
1A	52S05F		Screw C'sunk	18
1B	17S06		Washer Spring	18
1C	7S05		Nut	18
2	514405900		Bottom Wear Plate NearDoor Opening	1
2A	52S05F		Screw C'sunk	4
2B	17S06		Washer Spring	4
2C	7S05		Nut	4
2D	52S05K		Screw C'sunk	5
2E	17S06		Washer Spring	5
2F	7S05		Nut	5
3	514406000		Door Wearing Plate	1
3A	52S05H		Screw C'sunk	9
3B	17S06		Washer Spring	9
3C	7S05		Nut	9
PAN WITH 2 DOORS				
1	514406100		Bottom Wear Plate	2
1A	52S05F		Screw C'sunk	12
1B	17S06		Washer Spring	12
1C	7S05		Nut	12
2	514405900		Bottom Wear Plate NearDoor Opening	2
2A	52S05F		Screw C'sunk	8
2B	17S06		Washer Spring	8
2C	7S05		Nut	8
2D	52S05K		Screw C'sunk	10
2E	17S06		Washer Spring	10
2F	7S05		Nut	10
3	514406000		Door Wearing Plate	2
3A	52S05H		Screw C'sunk	18
3B	17S06		Washer Spring	18
3C	7S05		Nut	18
PAN WITH 3 DOORS				
1	514406100		Bottom Wear Plate	1
1A	52S05F		Screw C'sunk	6
1B	17S06		Washer Spring	6
1C	7S05		Nut	6
2	514405900		Bottom Wear Plate NearDoor Opening	3
2A	52S05F		Screw C'sunk	12

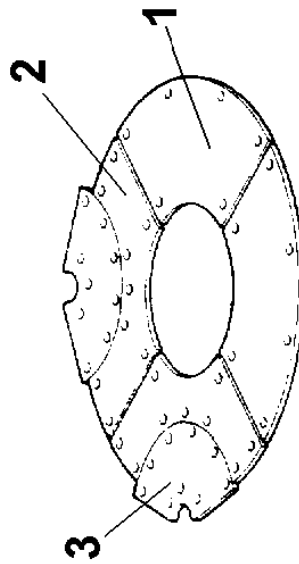
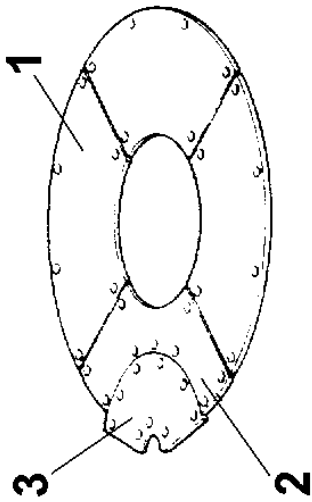
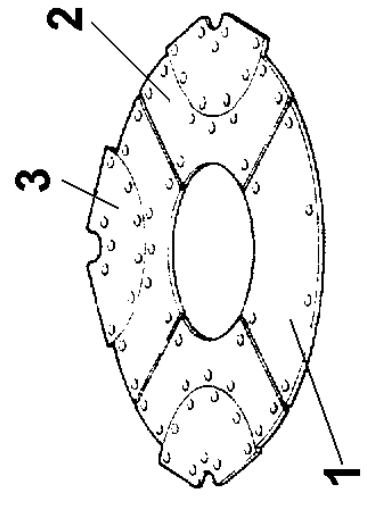
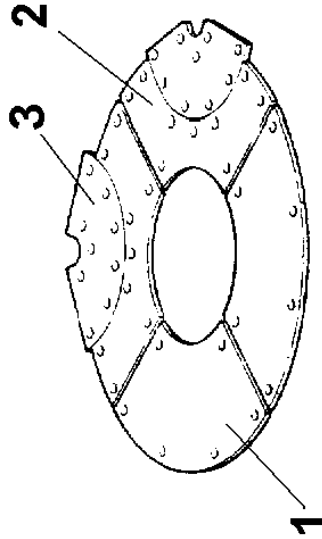
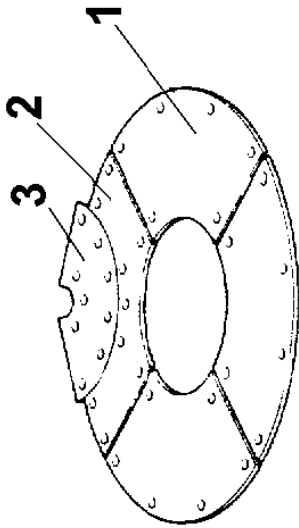
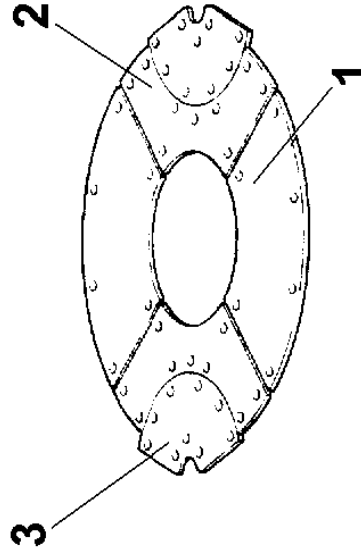
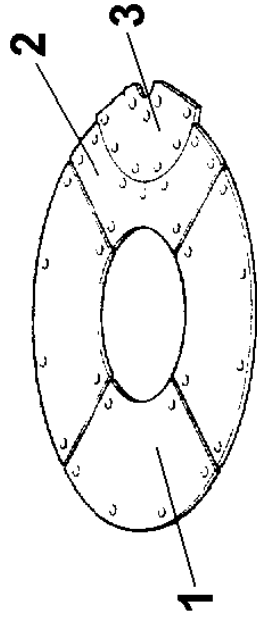

PAN BASE WEAR PLATES ASSEMBLY

A - 3

Item	Part no	Serial no	Description	Qty
PAN WITH 3 DOORS, CONT				
2B	17S06		Washer Spring	12
2C	7S05		Nut	12
2D	52S05K		Screw C'sunk	15
2E	17S06		Washer Spring	15
2F	7S05		Nut	15
3	514406000		Door Wearing Plate	3
3A	52S05H		Screw C'sunk	27
3B	17S06		Washer Spring	27
3C	7S05		Nut	27

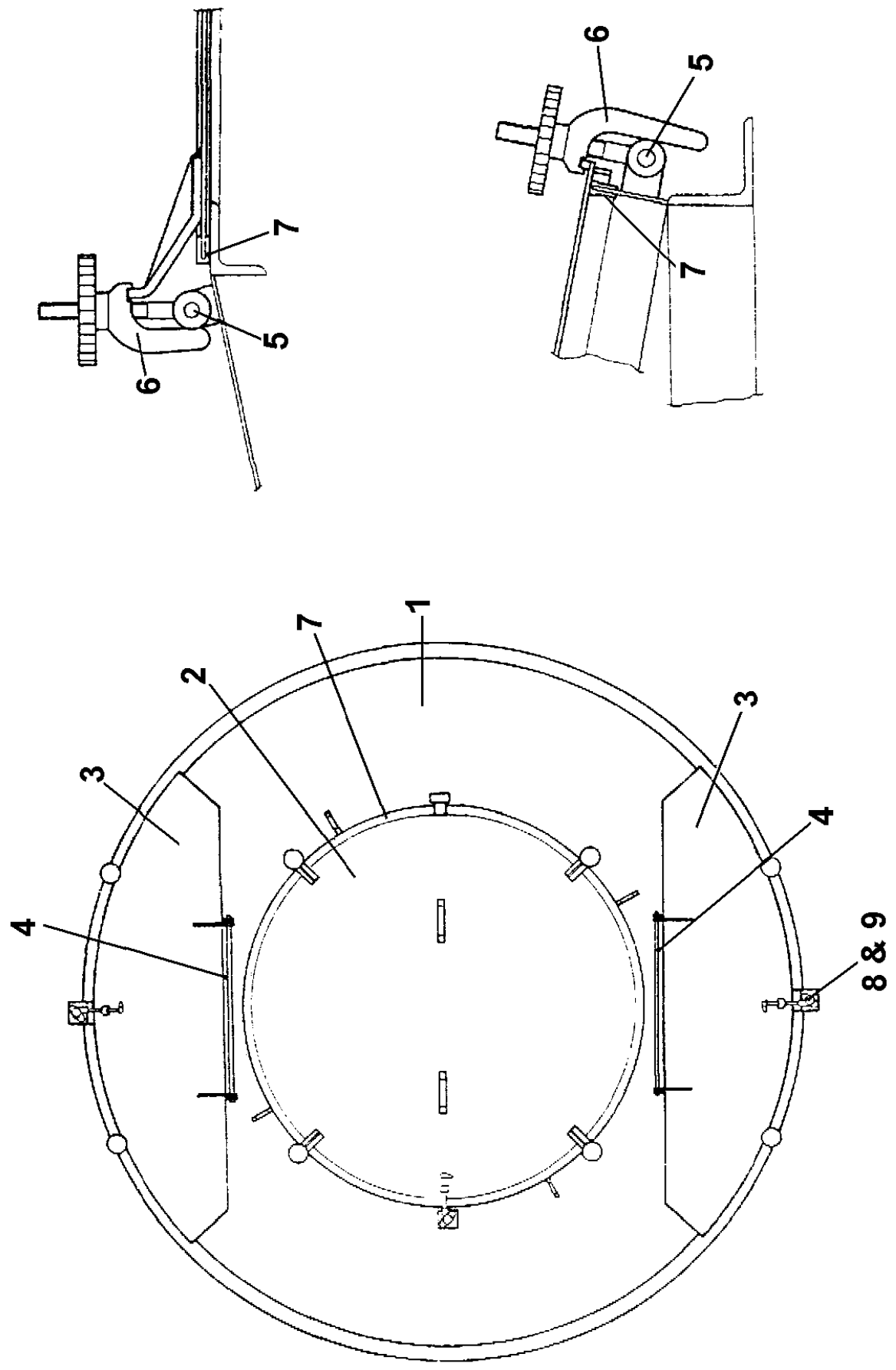

PAN COVERS ASSEMBLY

A - 4

Item	Part no	Serial no	Description	Qty
1	514437700		Cover Frame	1
1A	8S05D		Bolt	8
1B	105S05		Washer Tapered	8
1C	7S05		Nut	8
2	514437800		Cover Central	1
3	514437900		Hinged Lid	2
4	514425100		Hinge Shaft	2
4A	267S07			4
5	514425300		Clip Pin	8
5A	267S07		Washer Flat	16
5B	44S13H		Pin Split	16
6	314412000		Linadaptor c/w Eye Bolt & H/wheel	8
7	394910000		Neoprene Extrusion 8m Long	1
8	365126000		Interlock Assembly	3
8A	8S02E		Bolt	6
8B	267S04		Washer Flat	6
8C	61S02		Nut Binx	6
8D	11S02AA		Screw Set	6
8E	267S04		Washer Flat	6
9	365126001		Bolt Lock Type "K" (for Interlock)	3

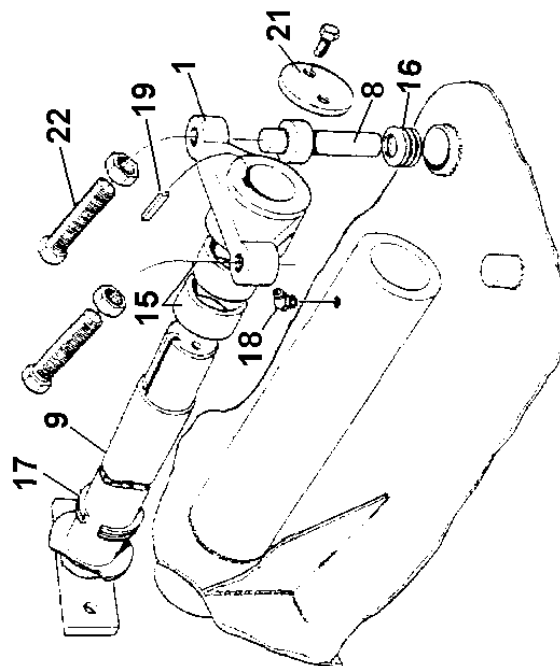
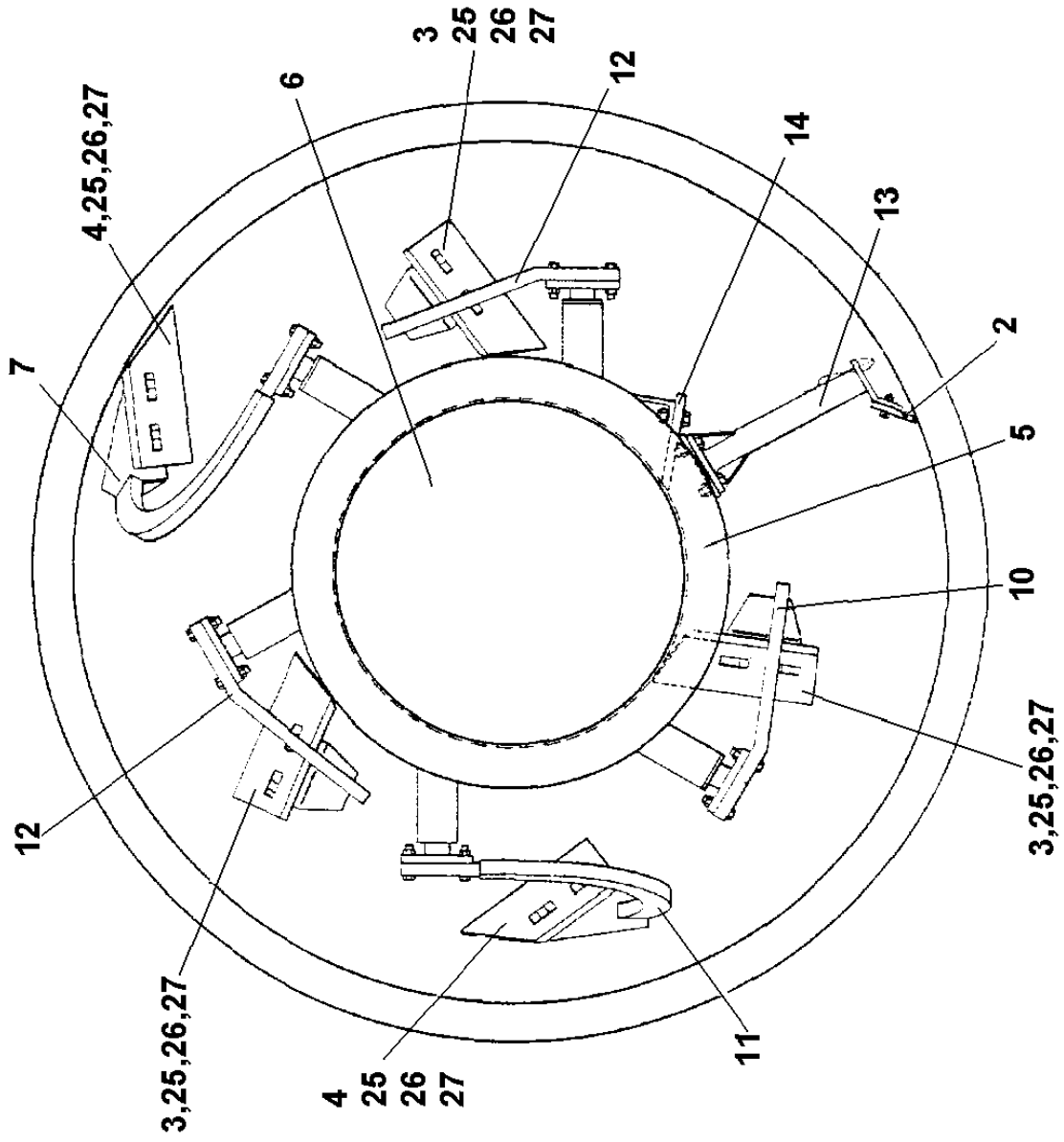

ROTOR AND BLADES ASSEMBLY

B-1

Item	Part no	Serial no	Description	Qty
1	514446700		Rotor Arm Rocker Shaft	5
2	514157800		Outer Scraper Blade	1
2A	8S06F		Bolt	2
2B	267S09		Washer Flat	2
2C	17S08		Washer Spring	2
2D	7S06		Nut	2
3	514295600		L.H. Paddle Blade (Inner)	3
4	514295700		R.H. Paddle Blade (Outer)	2
5	514402400		Rotor	1
5A	61S07		Nut Binx	6
6	514402500		Rotor Cover	1
6A	417735001		Inseal Strip (7' 6" Long)	1
6B	11S03A		Screw Set	12
6C	17S04		Washer Spring	12
7	514401100		Outer Mixing Blade Arm	1
7A	514448300		Special Bolt	2
7B	61S06		Nut Binx	2
8	514402000		Shock Absorber Pin	5
9	514447600		Rotor Arm Shaft	5
10	514400800		Inner Mixing Arm	1
10A	514448300		Special Bolt	2
10B	61S06		Nut Binx	2
11	514401000		Intermediate Mixing Blade Arm Type 2	1
11A	514448300		Special Bolt	2
11B	61S06		Nut Binx	2
12	514400900		Intermediate Mixing Blade Arm Type 1	2
12A	514448300		Special Bolt	4
12B	61S06		Nut Binx	4
13	514400600		Outer Scraper Arm	1
13A	8S06E		Bolt	4
13B	17S08		Washer Spring	4
13C	7S06		Nut	4
14	514400700		Inner Scraper Blade	1
14A	8S06F		Bolt	2
14B	267S09		Washer Flat	2
14C	17S08		Washer Spring	2
14D	7S06		Nut	2
15	514408600		Rotor Arm Bush	10
16	420475000		Disc Springs	140
17	417782000		V' Ring Seal	5
18	333754000		35' Grease Nipple	5

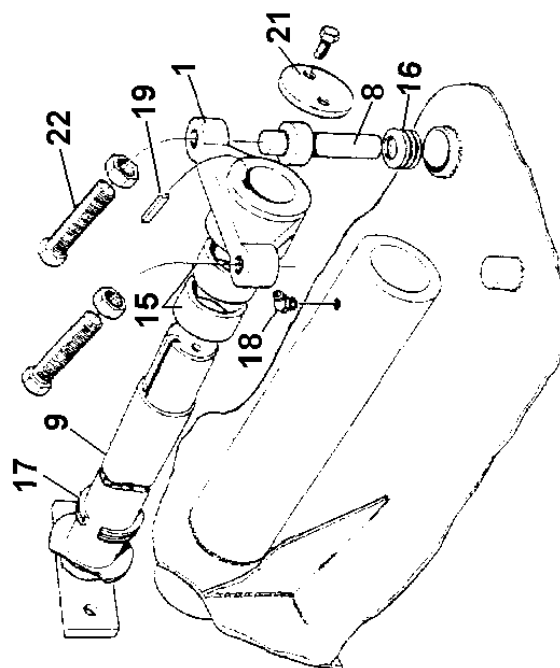
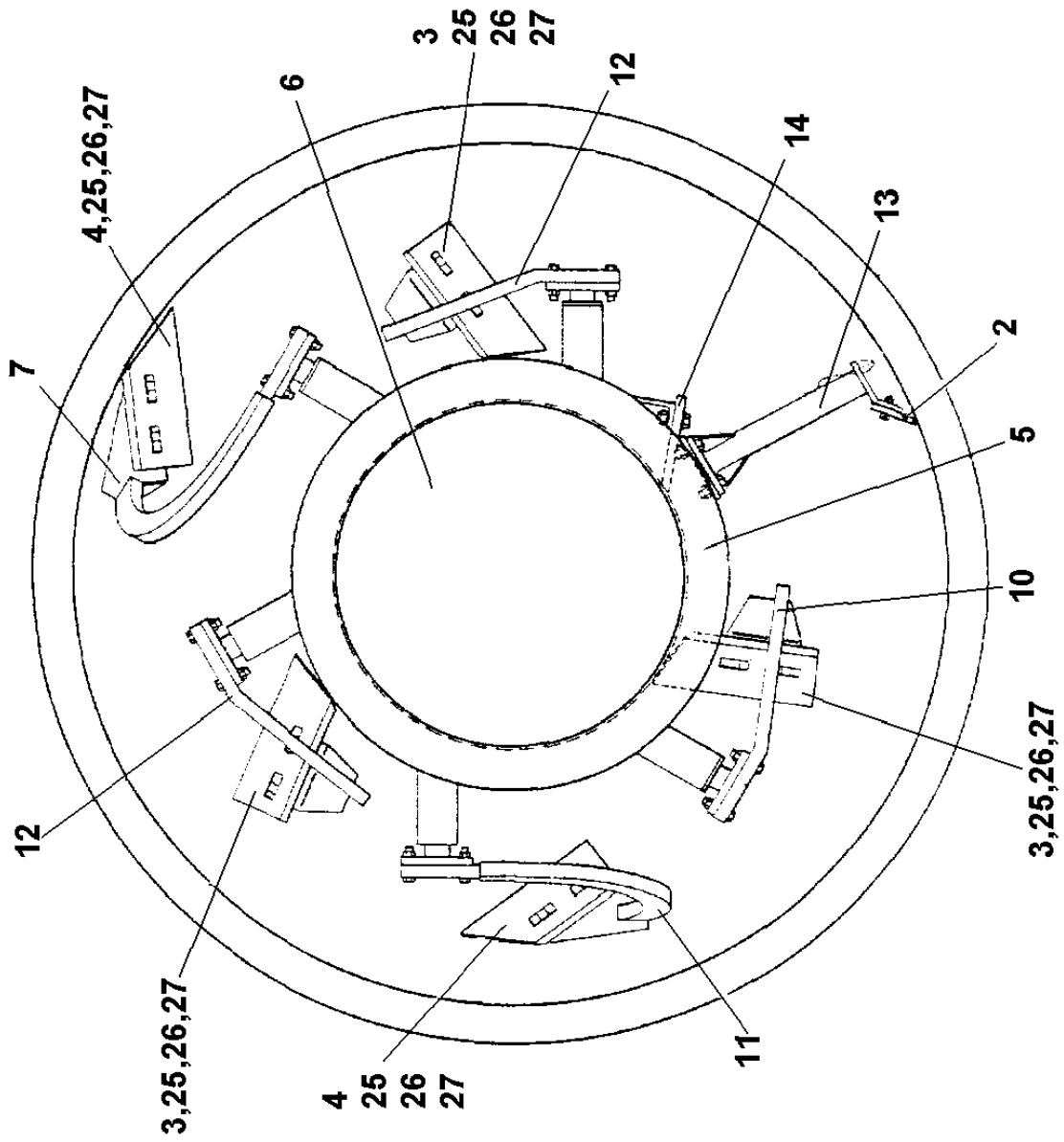

ROTOR AND BLADES ASSEMBLY

B-1

Item	Part no	Serial no	Description	Qty
19	305111245		Key Parallel	5
20	514406200		Mixing Arm Wearing Plate	
			Not Illustrated	10
21	514446800		Rotor Arm Shaft Locking Plate	5
21A	514446900		Screw, Locking Plate	10
22	11S06M		Screw Set	10
22A	7S06		Nut	10
23	514445200		Extended Outer Scraper Blade	
			Not Illustrated, for use with Mortar and Dry Mixes, Optional to Ref 2	1
23A	8S06F		Bolt	2
23B	267S09		Washer Flat	2
23C	17S08		Washer Spring	2
23D	7S06		Nut	2
24	514445100		Extended Inner Scraper Blade	1
			Not Illustrated, for use with Mortar and Dry Mixes, Optional to Ref 4	
24A	8S06F		Bolt	2
24B	267S09		Washer Flat	2
24C	17S08		Washer Spring	2
24D	7S06		Nut	2
25	514162400		Bolt, Square Head	10
25A	41S07		Washer Spring	10
25B	104S05		Nut Plain, Alternative to Ref 27	10
26	514162500		Washer for Paddle Blade, Special	10
27	192S05		Nut Binx 1/2" UNC, see Ref 25B	10

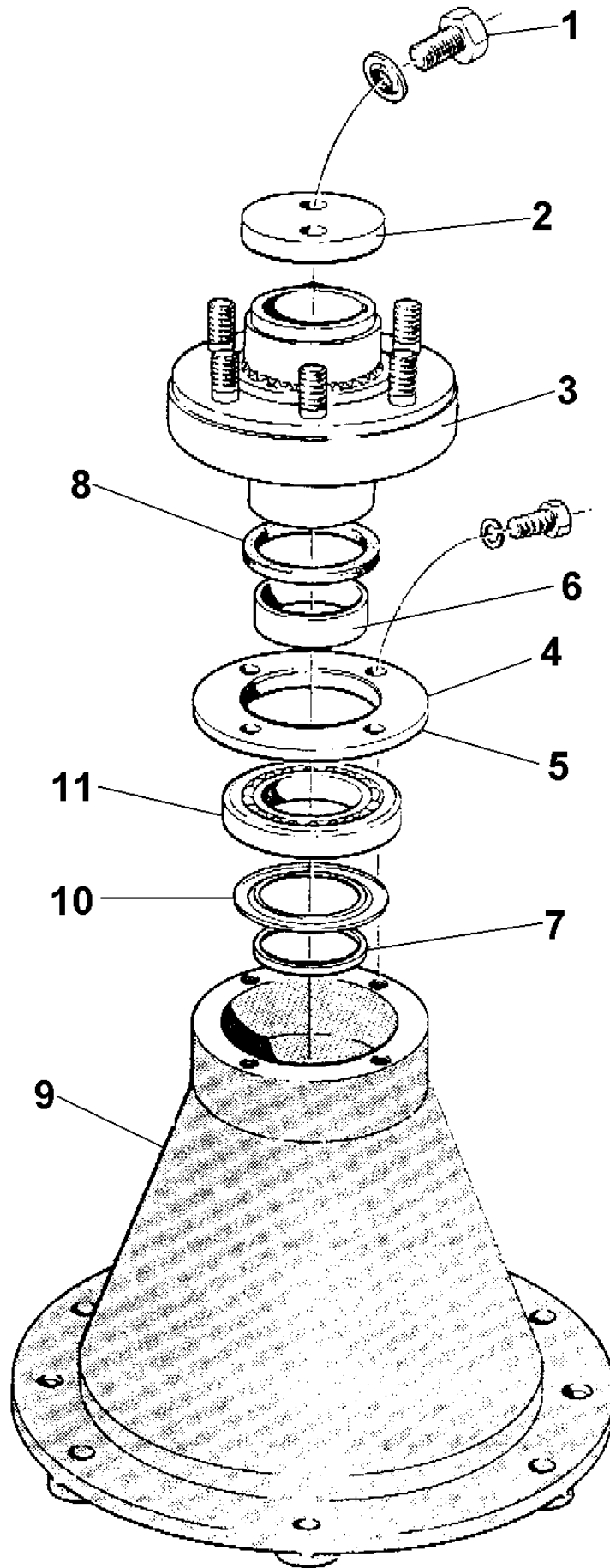

BELL HOUSING ASSEMBLY

B -2

Item	Part no	Serial no	Description	Qty
1	514408400		Special Setcrew	2
1A	100S03		Seal Bonded	2
2	514405500		Rotor Carrier Cap	1
3	514403700		Rotor Carrier	1
3A	411412050		Stud	6
3B	304712001		Key Parallel	1
4	514405800		Seal Housing	1
4A	11S04D		Screw Set	4
4B	17S05		Washer Spring	4
5	514408500		Seal Housing Gasket	1
6	514405700		Spacer	1
7	514405600		Short Spacer	1
8	417704900		Oil Seal	1
9	514406600		Bell Housing	1
9A	52S06P		Screw Set Csk Skt Hd	2
9B	411412080		Stud	6
9C	61S07		Nut Bnix	6
10	391621500		Nylos Ring	1
11	104475000		Bearing Ball	1

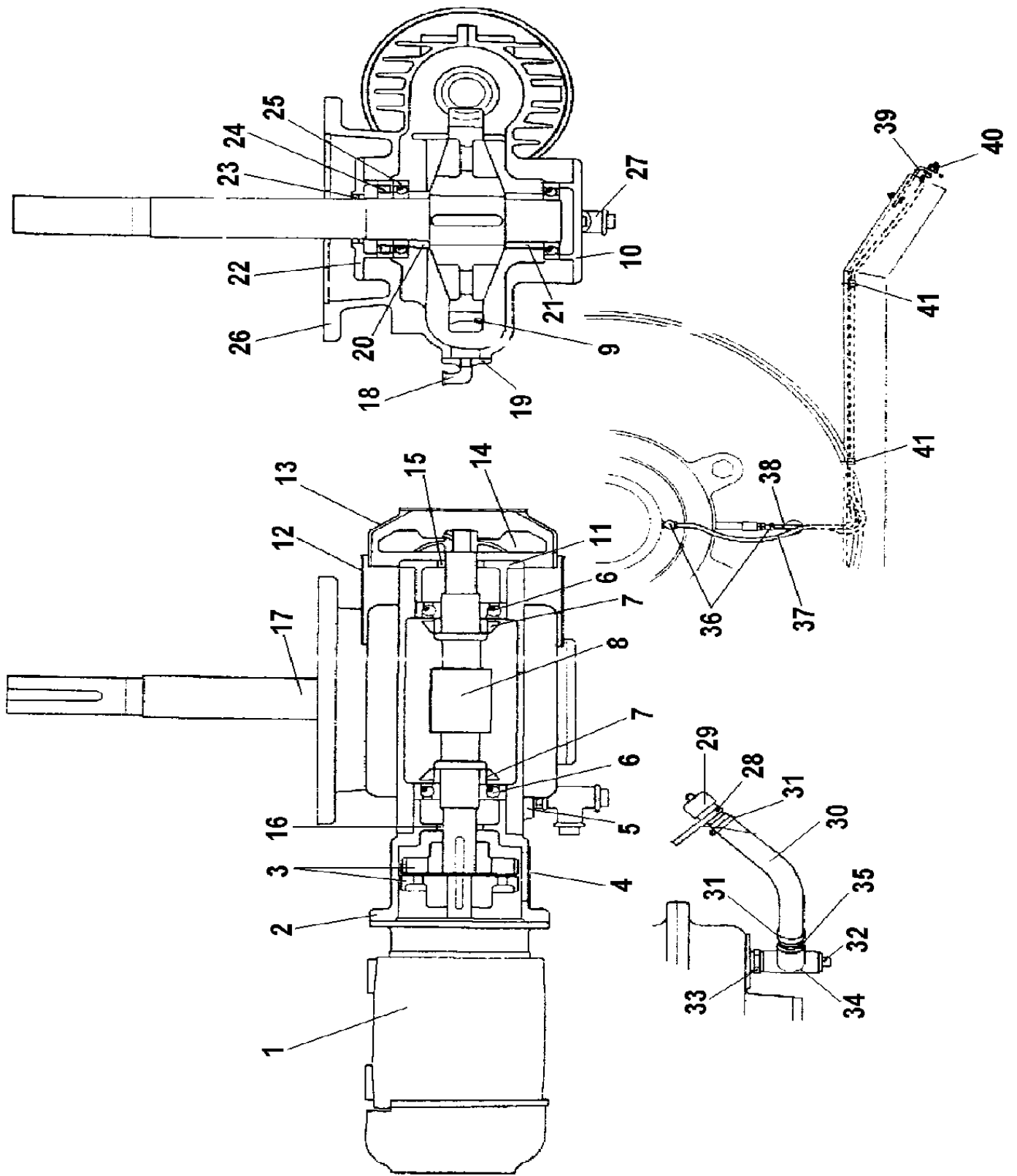

WORM GEARBOX DRIVE ASSEMBLY**B - 3**

Item	Part no	Serial no	Description	Qty
1	202436000		Motor Electric	1
2	254128001		Motor Adaptor D38208	1
3	254125002		Flexible Coupling C7663	1
4	254128003		Slow Speed Shaft C38209	1
5	254128004		Motor Adaptor Inspection Cover B38363	1
6	254128005		Motor Adaptor Oil Seal W30022550	1
7	254128006		Wormshaft	1
8	254128007		Wormshaft Ball Bearings MJT2.25	1
9	254128008		Deflector C7681	1
10	254128007		Wormshaft Ball Bearings MJT2.25	1
11	254128009		Wormshaft Open Cover B33953	1
12	254128010		Wormshaft Oil Seal W26920050	1
13	254128011		Fan B4820	1
14	254128012		Fan Cowl B6358	1
15	254125003		Inspection Cover B38363	1
16	254128013		Filler and Breather	1
17	254128014		Stauffer	1
18	254128015		Spacer Narrow B4822	1
19	254128016		Slow Speed Shaft Open Cover B36952	1
20	254128017		Slow Speed Shaft Oil Seal W40032550R4	2
21	254128018		Roller Bearing LRJ3.25	1
22	254128019		Slow Speed Shaft Ball Brgs LJT3.25	1
23	254128020		Gear Case F38362	1
24	254125017		Breather Cover	1
25	254128021		Tee Joint	1
26	254128022		Worm Wheel C25536	1
27	254128023		Slow Speed Shaft Band Cover B8415	1
28	254128019		Slow Speed Shaft Ball Brgs LJT3.25	1
29	254128024		Spacer Wide B4823	1
30	514406700		Hose Adator	1
31	514406800		Oil Filler Cap	1
32	514406900		Adaptor Plate	1
32A	11S04E		Screw Set	2
32B	17S05		Washer Spring	2
32C	7S04		Nut	2
33	260192240		Hose 570mm long	1
34	132102200		Hose Clip	2

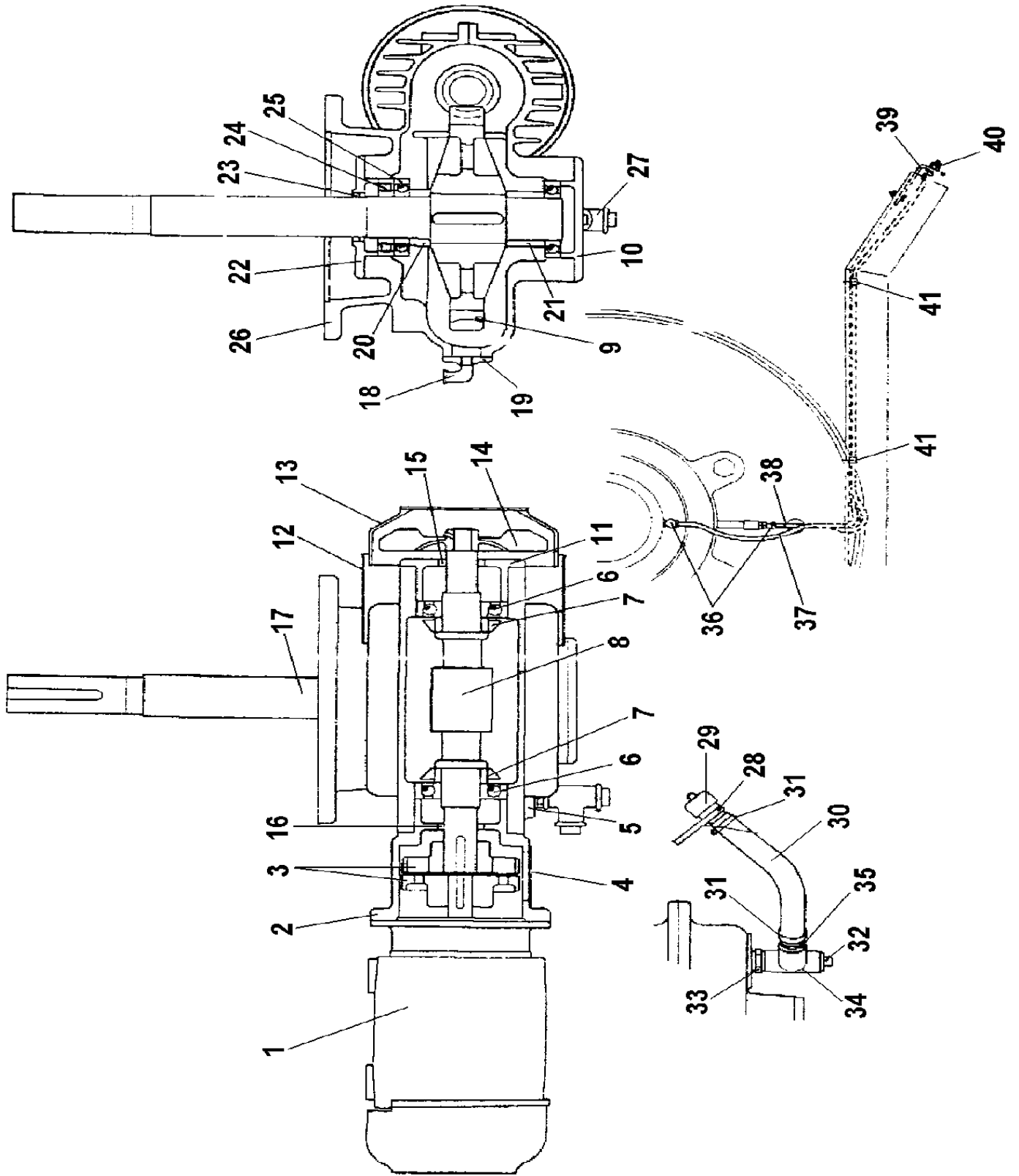

WORM GEARBOX DRIVE ASSEMBLY

B - 3

Item	Part no	Serial no	Description	Qty
35	130708200		Straight Connector	2
36	110950000		Nylon Tube (1.4m long)	1
37	110950000		Nylon Tube (1.0m long)	1
38	514407800		Greaser Battery Plate	1
38A	11S03D		Screw Set	2
38B	17S04		Washer Spring	2
38C	7S03		Nut	2
39	315815000		Battery Plate Adaptor	2
40	132841000		"P" Clip	2
40A	16S05VD		Screw Pan Hd Slit	2
40B	17S10		Washer Spring	2
40C	7S09		Nut	2
41	514407700		Motor Mounting Angle	1
41A	11S05H		Screw Set	2
41B	17S06		Washer Spring	2
41C	7S05		Nut	2
41D	11S06F		Screw Set	2
41E	267S09		Washer Flat	2
41F	17S08		Washer Spring	2
41H	7S06		Nut	2
	254128000		Worm Gearbox c/w Coupling	1
	254128025		Worm Gearbox with Electric Motor	1

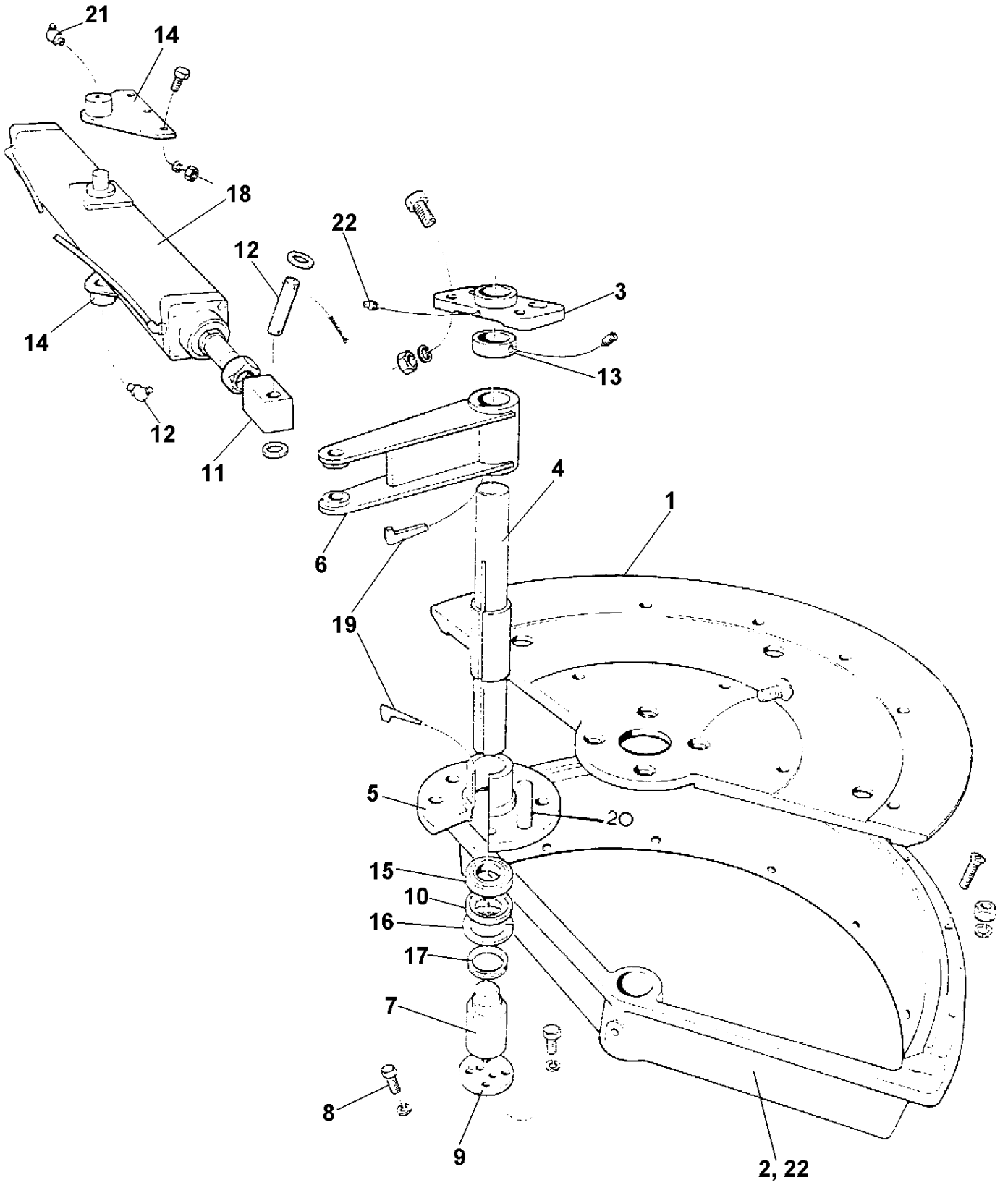

DISCHARGE DOOR ASSEMBLY

C - 1

Item	Part no	Serial no	Description	Qty
1	514404600		Discharge Door	1
1A	52S05G		Screw Set Csk Hd	4
2	514404700		Discharge Door Outlet	1
2A	52S05H		Screw Set Csk Hd	3
2B	17S06		Washer Spring	3
2C	7S05		Nut	3
3	514403000		Top Bearing	1
3A	8S05E		Bolt	4
3B	17S06		Washer Spring	4
3C	7S05		Nut	4
4	514403200		Door Shaft	1
5	514403400		Door Bearing	1
6	514404400		Discharge Door Lever	1
7	514403300		Door Journal	1
8	514407900		Screw Set Special	4
8A	17S06		Washer Spring	4
9	514402600		End Plate	1
9A	11S05C		Screw Set	2
9B	17S06		Washer Spring	2
10	514402700		Sealing Ring	1
11	514445300		Rod End	1
12	514402900		Rod End Pin	1
12A	267S10		Washer Flat	2
12B	44S16H		Pin Split	2
13	514404100		Collar	1
13A	57S07E2		Screw Grub	1
14	514404300		Air Cylinder Pivot Plate	2
14A	8S05D		Bolt	6
14B	17S06		Washer Spring	6
14C	7S05		Nut	6
15	104450000		Bearing Ball	1
16	391702000		Retaining Ring	1
17	417755000		V' Ring Seal	1
18	137109000		Air Cylinder	1
18A	137109002		Nut Lock	
18B	74S09		Nut Lock, alternative to 18A	1
19	304314100		Key Gib Head	2
20	353221635		Dowel	2
21	333601010		Nipple Grease 1/4" BSP 45'	2
22	333104020		Nipple Grease 1/4" BSP Straight	2

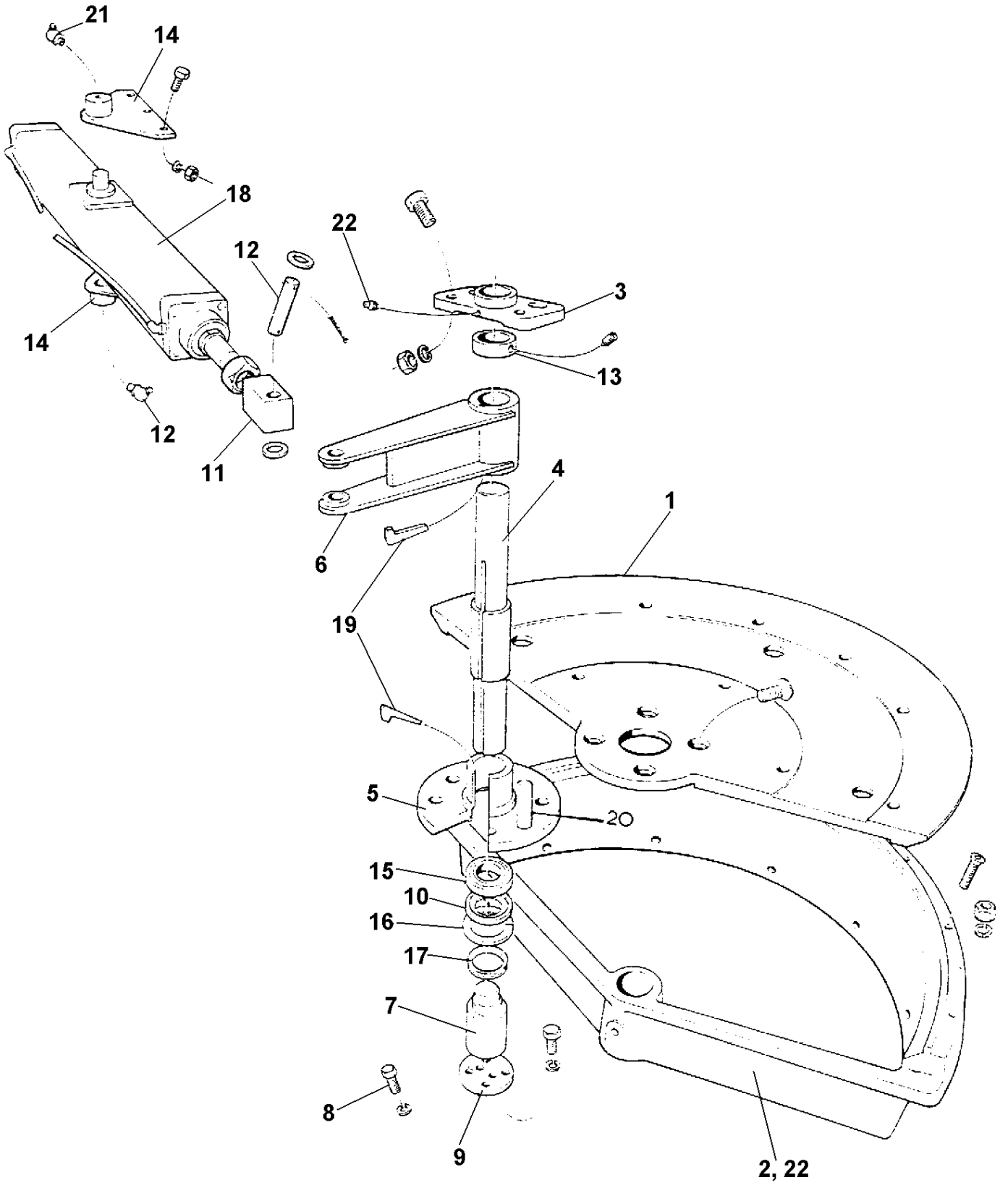

DISCHARGE DOOR ASSEMBLY

C - 1

Item	Part no	Serial no	Description	Qty
23	514406500		Discharge Chute (not illus)	1
23A	11S05B		Screw Set	4
23B	17S06		Washer Spring	4
24	137109001		Spares Kit for Air Cylinder (not illus)	1
			Alternative Hydraulically Operated Discharge Door Cylinder, not illustrated	
	514438800			1

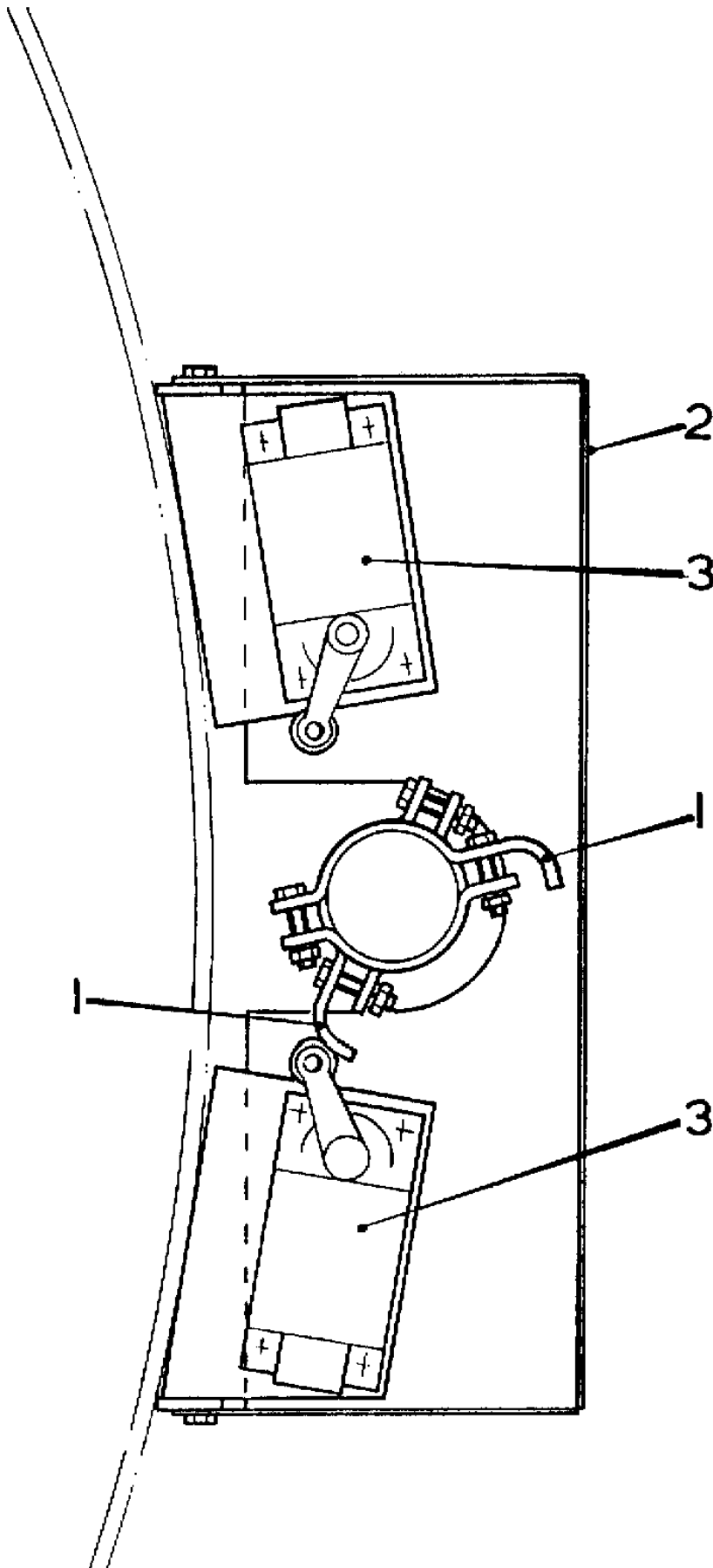

DOOR LIMIT SWITCH ASSEMBLY

C -2

Item	Part no	Serial no	Description	Qty
1	514407000		Limit Switch Actuator	2
1A	11S03D		Screw Set	4
1B	17S04		Washer Spring	4
1C	7S03		Nut	4
2	514411400		Limit Switch Cover	1
2A	11S03AA		Screw Set	4
2B	17S04		Washer Spring	4
3	208511000		Limit Switch	2
3A	11S02B		Screw Set	8
3B	17S03		Washer Spring	8
3C	7S02		Nut	8

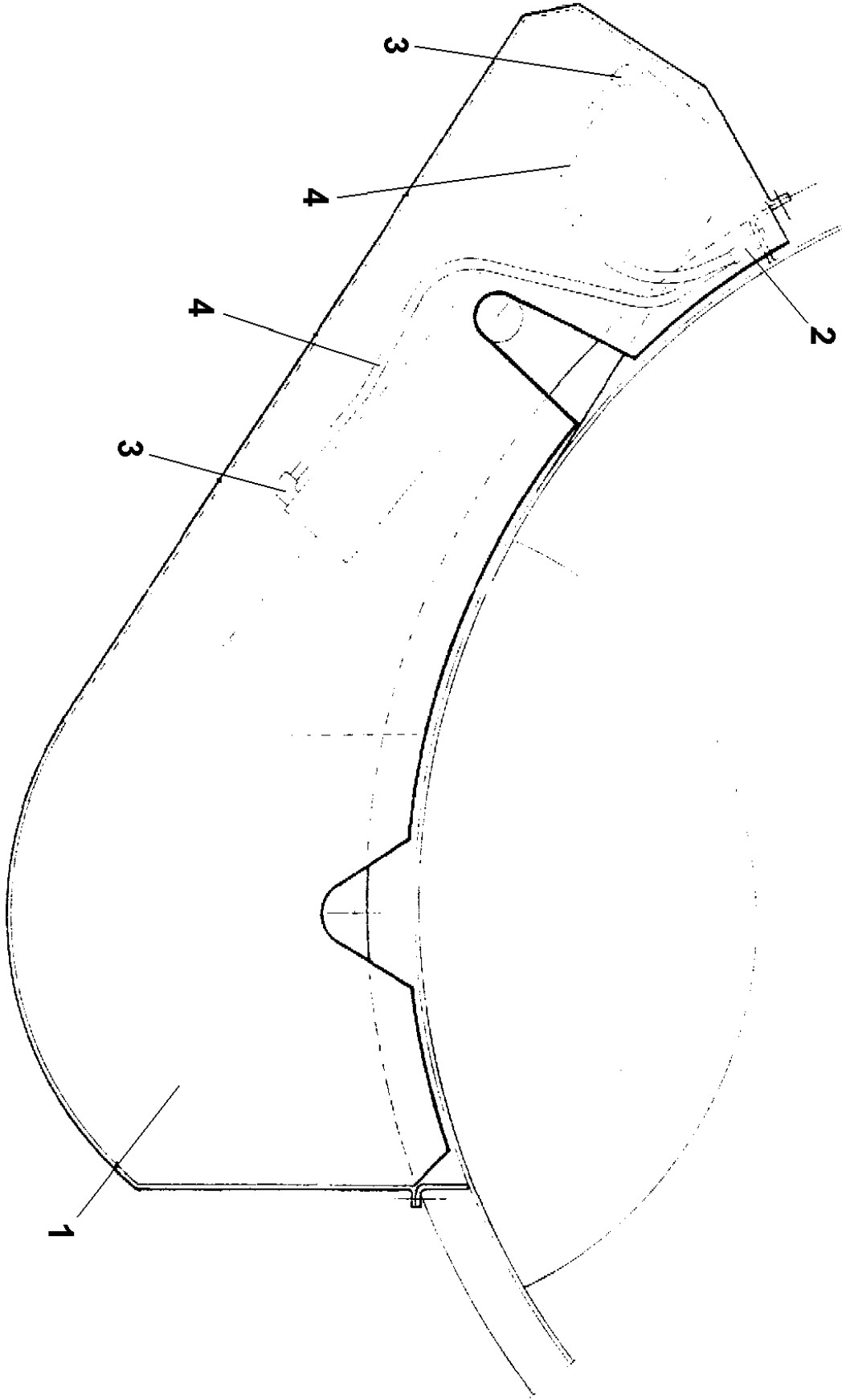

DOOR CYLINDER GUARD ASSEMBLY

C -3

Item	Part no	Serial no	Description	Qty
1	514413900		Door Cylinder Guard Assembly	1
1A	11S03B		Screw Set	6
1B	17S04		Washer Spring	6
1C	7S03		Nut	6
2	231161200		Bulkhead Fitting	2
3	231091221		Male Stud Adaptor Elbow	2
4	110951200		Nylon Tube (760mm long)	2

