

WINGET

OPERATING INSTRUCTIONS & SPARE PARTS LIST

FOUR/45 C.D.P. DIESEL DUMPER WITH HAMWORTHY AXLES

**(CAPACITY 45 CWT)
ISSUED JULY 1977
REVISED APRIL 1978
REPRINTED AUGUST 2002**

**WINGET LIMITED
PO BOX 41
EDGEFOLD INDUSTRIAL ESTATE
PLODDER LANE
BOLTON
LANCS
BL4 OLS**

**TEL: ++ 44 (0) 1204 854650
FAX: ++ 44 (0) 1204 854663
service@winget.co.uk
parts@winget.co.uk
www.winget.co.uk**

INTRODUCTION

This Parts & Operators Manual is a re-print of the manual last published in 1978 and contains some amended part numbers.

Note: this publication is applicable to machines with serial numbers from and including 4/45-7457

Health & Safety legislation and working practices applicable to Site Dumpers, both 2 and 4 wheel Drive, Rigid Chassis and Articulated Chassis have changed considerably in the years since this manual was last published and immediately following this Introduction are notes on the Safe Use of Site Dumpers. These notes supersede and replace all previous 'Dumper Safety' notes issued with Winget FOUR/45 Central Driving Position (C.D.P.) Four Wheel Drive Dumpers fitted with Hamworthy Axles.

Reference is made on a number of pages to 'bolt c/w nut and washer', this no longer the case, fixings such as nuts, bolts, screws and washers should be ordered as individual items. A number of Whitworth and B.S.F fixings are now no longer available, in these cases the nearest metric equivalent size will be supplied.

The contents of this manual although correct at the time of publication, may be subject to alteration by the manufacturers without notice and Winget Limited can accept no responsibility for any errors or omissions contained within the following pages. Nor can we accept any liability whatsoever arising from the use of this manual howsoever caused.

Winget Limited operate a policy of continuous product development. Therefore, some illustrations or text within this publication may differ from your machine.

WINGET LIMITED
PO BOX 41
EDGEFOLD INDUSTRIAL ESTATE
PLODDER LANE
BOLTON
LANCS
BL4 OLS
TEL ++ 44 (0) 1204 854650
FAX ++ 44 (0) 1204 854663
E mail service@winget.co.uk
parts@winget.co.uk
www.winget.co.uk

DUMPER SAFETY

Safety is the responsibility of all persons working with this machine. Think "safety" at all times. Read and remember the contents of this handbook.

MACHINE MODIFICATIONS

WARNING Any modifications to the machine will affect its working parameters and safety factors. Refer to the Manufacturers before fitting any non-standard equipment or parts.



The Manufacturers accept no responsibility for any modifications made after the machine has left the factory, unless previously agreed by the Manufacturers in writing; the Manufacturers will accept no liability for damage to property, personnel or the machine if failure is brought about due to such modifications, or fitment of spurious parts.

TRAINING

WARNING Only trained operators should use this machine.



Operators should hold an appropriate full motor vehicle driving licence and undergo both a safety awareness course and a driver training course for Site dumpers run by the C.ITB or equivalent body leading to the award of a CTA.

It is strongly recommended that operators read the H.S.E. publication "Safe Working with Small Dumpers" which is available from government bookshops (HMSO) or from other bookshops quoting the following number ISBN 011 8836935. Another useful publication is British Standard number BS 6264, "Procedure for Operator Training For Earth Moving Machinery" available from the British Standard Institution.

OPERATION

WARNING NEVER use the machine for purposes other than those for which it was designed. This machine was designed to carry loads such as soil, clay, sand, wet concrete, stone or other similar materials. It was not designed to carry loads which may move around in the skip uncontrollably, nor to carry any loads or materials which overhang the skip in any way. If in any doubt as to the suitability of this machine for a particular task, contact your nearest Distributor or the Manufacturer for advice.



ALWAYS be aware of local and national regulations governing the use of the machine.

NEVER commence work with the machine until the "Daily (or every ten hours)" service checks have been made. (See Service Section for details)

ALWAYS check wheel nut tightness daily.

NEVER carry passengers.

Where seat belt restraints are fitted as part of Rops/Fops Protection they must be worn. Ensure that the seat and seat belt are securely fixed to the machine. Check that the seat belt is in good condition, free from cuts and frayed edges.

ALWAYS remain in the driving seat whenever the engine is running. Never attempt to operate any controls unless seated.

ALWAYS apply the parking brake before leaving the driver's seat.

DUMPER SAFETY

NEVER dismount with the engine running, and never leave the machine unattended with the key in the starter switch.

When Battery Isolators are fitted they must be activated only when the engine is turned off except in cases of emergency.

Activating a Battery Isolator when the engine is running can result in damage to the electrical components and circuits.

NEVER fill the fuel or hydraulic tanks with the engine running.

ALWAYS drive only on surfaces that are known to be stable.

ALWAYS keep the floor plates and walkways clean.

NEVER drive the machine close to the edge of any excavation. Always use effective wheel stops to prevent the machine running close to the edge. Make sure that the stops are in proportion to the size of the wheels and are set sufficiently far enough back from the edge of any excavation to prevent the weight of the load causing a collapse.

NEVER adjust the tyre pressures in an attempt to improve traction on soft ground or obtain a softer ride on hard ground. Incorrectly adjusted tyres can affect the steering and handling characteristics.

NEVER attempt to free a machine which is 'bogged down' by pushing with the bucket of a backhoe loader, tracked excavator or other similar machine.

NEVER make unnecessary "crash stops" when travelling at speed, especially in forward direction.

NEVER work under an unpropped skip. *If the dumper was supplied with a special Skip Support always ensure that it is used.*

Some articulating dumpers are manufactured with an articulation lock. If your machine has this feature proceed as follows:

ALWAYS fit the articulation lock when working within the articulation point crush zone.

NEVER attempt to lift the machine unless the articulation lock is engaged.

SKIPS AND LOADING

WARNING *NEVER* exceed the rated payload. The weights of all loads above skip water level must be checked.



NEVER remain on the machine when loading the skip with excavators or loaders. Stop the engine, apply the parking brake, dismount, and stand well clear.

ALWAYS ensure that the load is evenly distributed in the skip.

NEVER carry loads or heap materials in such a manner as to affect the forward vision.

ALWAYS take extra care when tipping non free running loads.

NEVER use the skip in a tipped position to bulldoze heaped materials level or to backfill material into excavations.

DUMPER SAFETY

TOWING

WARNING NEVER attempt to start the engine of a dumper by towing or pushing.



Dumpers are not designed as towing vehicles, but loads (including weight of trailer) not exceeding the rated payload of the dumper may be towed on dry level ground in first gear, providing the dumper skip is loaded with half the rated payload to ensure tyre adhesion when braking.

ALWAYS use a purpose made towing pin.

NEVER tow loads up, down or across gradients.

GRADIENTS

WARNING NEVER operate *Four Wheel Drive articulated steer dumpers* on any gradients which exceed 25% (1 in 4), or across gradients which exceed 16% (1 in 6).



NEVER operate *Two Wheel Drive rigid chassis dumpers* on any gradients which exceed 10% (1 in 10), or across gradients which exceed 10% (1 in 10).

ALWAYS remember that slippery or loose surface conditions can adversely affect safe machine operation, including braking, particularly on gradients.

ALWAYS choose routes that avoid steep, slippery or loose gradients.

NEVER coast down gradients. Always negotiate gradients in first gear.

ALWAYS drive forwards up gradients when loaded.

ALWAYS reverse down gradients when loaded.

ALWAYS keep the load facing uphill.

NEVER park on a gradient. If this is unavoidable, ALWAYS chock the wheels.

NEVER attempt to turn on a gradient.

NEVER tow up, down or across a gradient.

NEVER operate high discharge or rotating skips on gradients.

HYDRAULICS

WARNING ALWAYS "Dump" residual pressure from the system before leaving the machine or before carrying out any maintenance or adjustments.



If maintenance work requires the skip to be in the raised position, then it must be raised and supported before dumping the pressure.

Dump pressure by switching off the engine, then moving the hydraulic control lever several times in each direction.

NEVER leave the machine unattended with pressure in the system.

ALWAYS purge hydraulic rams before commencing work. With the engine running operate the hydraulic control to fully extend and retract the rams.

ALWAYS practise the greatest cleanliness in maintaining hydraulic components.

DUMPER SAFETY

SERVICING

WARNING ALWAYS report any defect at once, before an accident or consequential damage can occur.



ALWAYS conform to service schedules except where:

- 1 Warning lights or warning indicators call for immediate attention.
- 2 Adverse conditions necessitate more frequent servicing.

ALWAYS wear correctly fitting protective clothing. Loose or baggy clothing can be extremely dangerous when working on running engines or machinery.

ALWAYS, where possible, work on or close to engines or machinery only when they are stopped. If this is not practical, remember to keep tools, test equipment and all parts of your body well away from the moving parts.

ALWAYS dump pressure from the hydraulic system before carrying out any kind of maintenance or adjustment. (*see Hydraulics Warnings*).

ALWAYS avoid contact with exhaust pipes, exhaust manifolds and silencers when the engine is running; these can be very hot.

ALWAYS work out of doors, or in a well-ventilated area.

NEVER run an engine in an enclosed space. Exhaust fumes in enclosed areas can kill.

ALWAYS disconnect battery cables and remove battery before using an external charger, carrying out welding repairs or to prevent unauthorised usage when unattended or during a repair.

NEVER allow unqualified personnel to attempt to repair, remove or replace any part of the machine, or anyone to remove large or heavy components without adequate lifting tackle.

NEVER attempt to modify or repair Rops Frames or Fops Canopies by welding, drilling or any other means. Attempts to do so will invalidate Rops/Fops Certification.

ALWAYS obtain advice before mixing oils; some are incompatible. If in doubt drain and refill.

NEVER allow oils and fuels to come into regular contact with skin. This can lead to serious skin diseases including, medical evidence suggests, skin cancer. ALWAYS wear protective gloves when handling oils and fuels whether topping up, draining or refilling. ALWAYS wash hands if oils or fuels come into contact with the skin.

Many liquids used in this machine are harmful if taken internally or splashed into the eyes. In the event of accidentally swallowing oils, fuels, anti-freeze, battery acid etc, DO NOT encourage vomiting, seek qualified medical assistance immediately.

ALWAYS dispose of waste oils and fuels into waste oil storage tanks. If storage tanks are not available consult your distributor or local authority for addresses of local designated disposal points. It is illegal to dispose of waste oil into drains or water courses or to bury it.

DUMPER SAFETY

Equipment which includes friction materials will sometimes contain asbestos. When removing friction material dust from components, such as when servicing brakes or clutches, do not blow out with an airline; it could be harmful to inhale the dust. Remove the dust with a vacuum cleaner or wipe clean with a damp rag. Waste should be placed in a sealed container, marked, and disposed of in accordance with local or national regulations.

The accumulated dust found in clutch housings may contain lead/antimony. No food should be eaten at a work place contaminated by this dust. Hands must be washed before eating. Do not blow out dust with an airline.

ALWAYS ensure that the starting handle is clean and in good condition. Keep the engine starting dog, and the part of the starting handle that mates with it, lightly lubricated (*Refer to the Engine Handbook*).

NEVER work under an unpropped skip. ***If the dumper was supplied with a special Skip Support always ensure that it is used.***

Some articulating dumpers are manufactured with an articulation lock. If your machine has this feature, ALWAYS fit the articulation lock when servicing or working on the machine.

PREPARATION FOR USE

Before the Dumper is put into service, always check the following points:

Engine

Check the oil level on the dipstick, topping up if necessary to the full mark.

Gearbox

Check the oil level on the dipstick, topping up if necessary to the full mark.

Drive Axles and Transfer Case.

Remove filler/level plugs from drive axles and filler/level plug from transfer case and check that oil is up to bottom of holes. Top up if necessary, through filler/level plugs.

Fuel Tank

Fill tank with diesel oil until approximately 1" from the top.

NOTE: Never allow fuel level to fall below 2" deep in the bottom of the tank.

Hydraulic Tank

Fill the hydraulic tank. Before removing the cap, clean the surrounding area to prevent the possible entry of foreign matter.

Brake System

Ensure that both brake cylinder reservoirs are full of fluid. Top up if necessary to within $\frac{1}{4}$ " of the top of the reservoirs. Use only brake fluid that conforms to B.S. – SAE.J.1703.

Miscellaneous

Check all wheel nuts for tightness

Check all nuts and bolts for tightness, loose nuts and bolts may lead to damage not covered by Warranty.

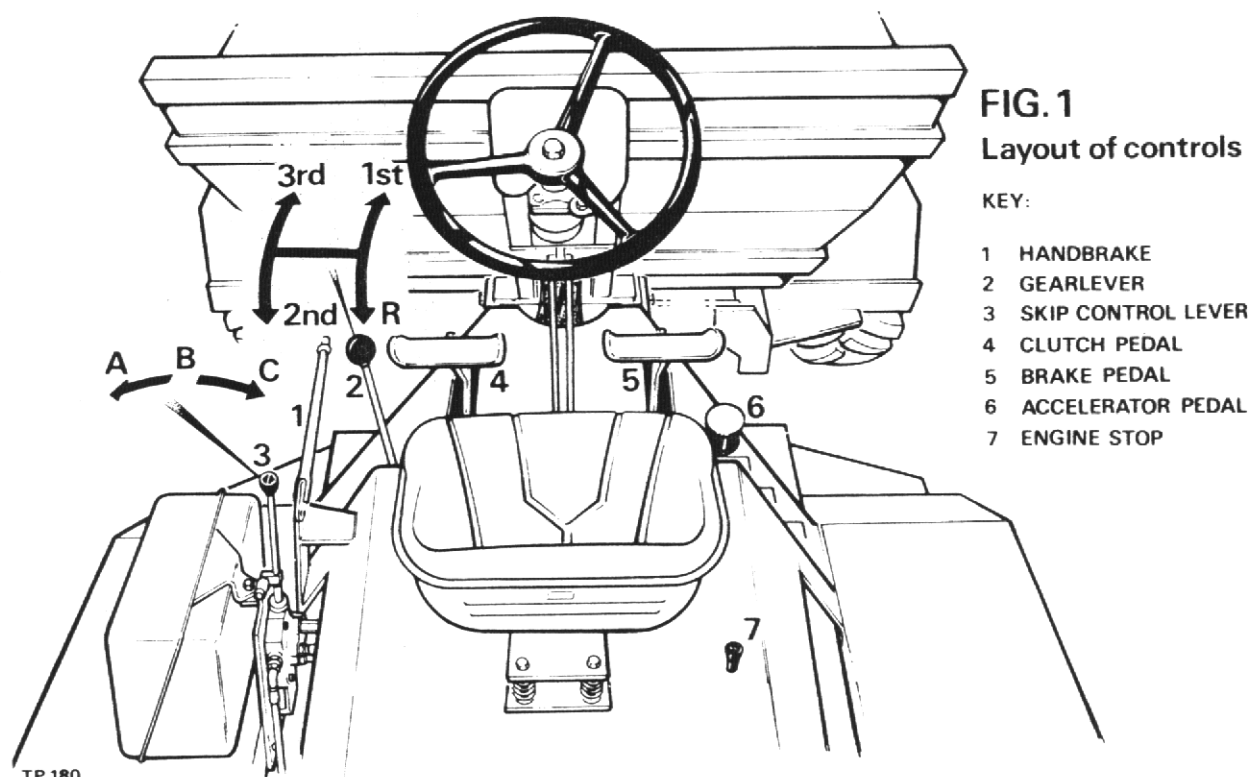

SPECIFICATION FOR MACHINES WITH FORWARD TIP SKIP

A	Overall height	6'-7"	(200 cm)
B	Skip loading height	4'-3"	(129 cm)
C	Wheelbase	5'-7 5/8"	(172 cm)
D	Overall length	12'-3 5/8"	(375 cm)
E	Ground clearance	11 1/2"	(29 cm)
F	Overall width	5'-9"	(175 cm)
G	Skip ground clearance when tipped	1'-4"	(40 cm)
H	Overall height tipped	7'-6 3/4"	(230 cm)
J	Discharge forward to tyre	1'-10"	(55 cm)
K	Overhang	3'-6 1/2"	(108 cm)
L	Wheeltrack	5'-0"	(152 cm)
M	Prow width	4'-8 1/2"	(144 cm)

Skip			Turning Circle	23'-8"	721 cm
Water level	32 cu. ft.	906 Litres	Unladen Weight	4312 lbs.	1957 kgms
Struck level	38 cu. ft.	1076 Litres	Hydraulic relief valve	1750 p.s.i.	123 kgs/cm ²
Heaped	48 cu. ft.	1359 Litres	Rear axle articulation	1'-2"	35 cm
Maximum payload	2 ton 5 cwt	2286 Kgm	Road Speeds	m.p.h.	km.p.h.
			1st	2.48	3.99
Tank Capacity			2nd	5.76	9.26
Hydraulic	6 gals	27 1/4 Litres	3rd	10.66	17.15
			Rev.	2.7	4.3

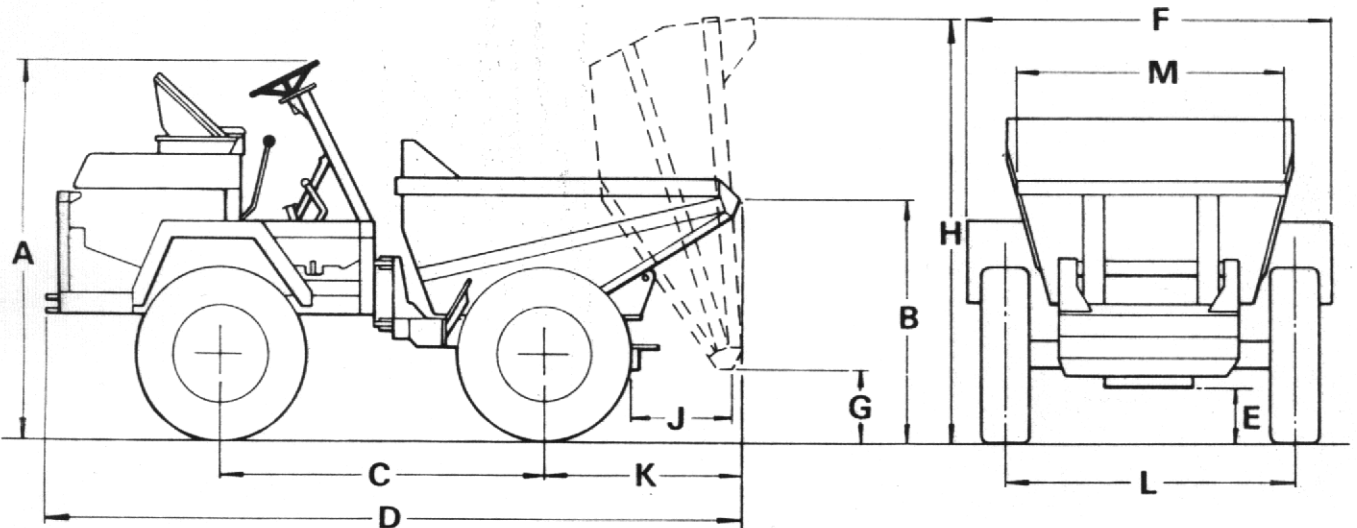

FIG. 2

SPECIFICATION FOR MACHINES WITH HIGH DISCHARGE SKIP

A	Overall height	6'-9"	(206 cm)
B	Skip loading height	6'-2"	(188 cm)
C	Wheelbase	5'-7 5/8"	(172 cm)
D	Overall length	11'-8 5/8"	(357 cm)
E	Ground clearance	11 1/2"	(29 cm)
F	Overall width	5'-9"	(175 cm)
G	Skip ground clearance when tipped	5'-9"	(175 cm)
H	Overall height tipped	11'-0"	(335 cm)
J	Discharge forward of tyre	1'-8 1/2"	(52 cm)
K	Overhang	3'-1/2"	(93 cm)
L	Wheeltrack	5'-0"	(152 cm)
M	Prow width	2'-2 1/2"	(67 cm)

Skip			Rear axle articulation	1'-2"	35 cm
Water level	34 cu.ft.	963 Litres	Road Speeds at 2000 r.p.m.	m.p.h.	km.p.h.
Struck level			1st	2.48	3.99
Heaped capacity			2nd	5.76	9.26
Maximum payload	2 tons	2032 kgms	3rd	0.66	17.15
Hydraulic relief valve set at			Rev	2.7	4.3
	1750 p.s.i.	123 kgm/cm ²			
Hydraulic tank capacity			Unladen weight		
	6 gals.	27 1/4 Litres		2 tons 0 cwt. 3 qtrs	
Ground clearance	11 1/2"	29 cm		2069 kgms	
Turning circle	23'-8"	721 cm			

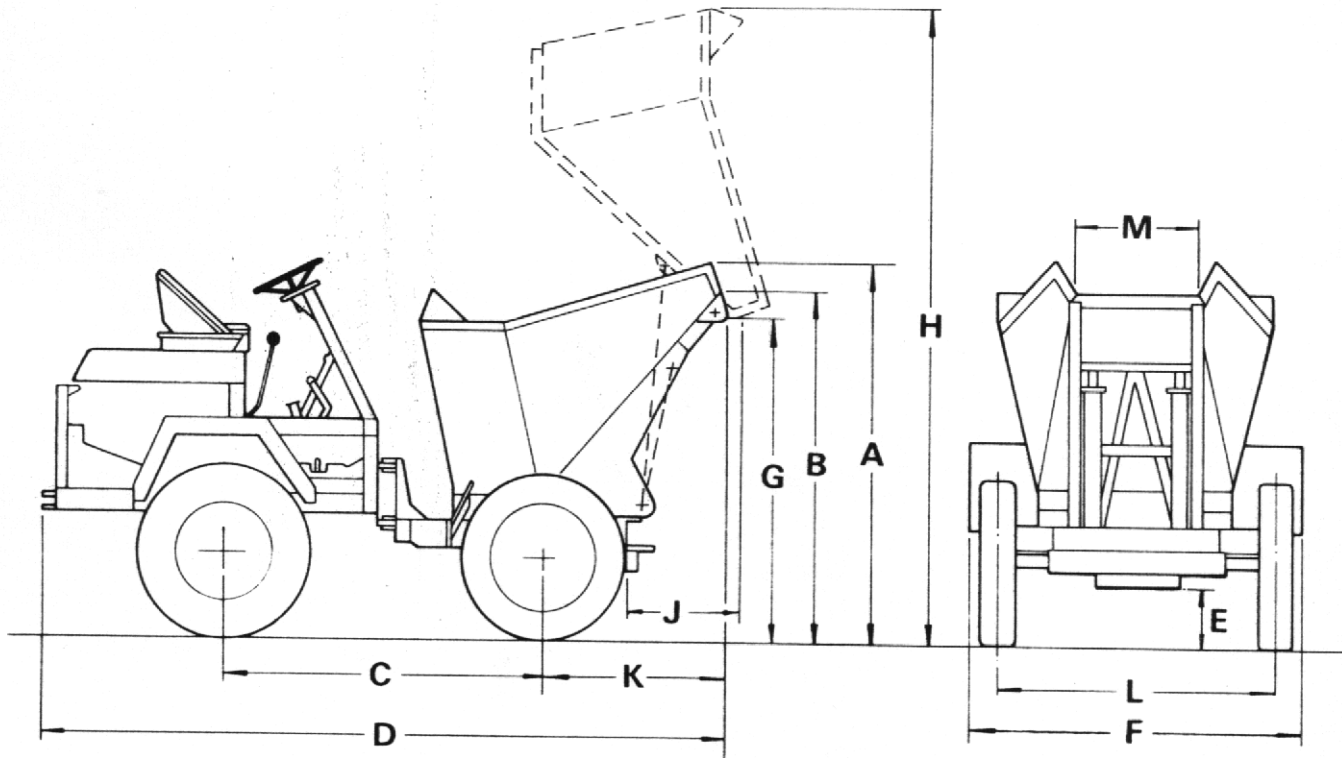

FIG. 3

SPECIFICATION FOR MACHINES WITH TURNTABLE NARROW MOUTH SKIP

A	Overall height	6'-7"	(200 cm)
B	Skip loading height	4'-8"	(142 cm)
C	Wheelbase	5'-7 5/8"	(172 cm)
D	Overall length	12'-1"	(368 cm)
E	Ground clearance	11 1/2"	(29 cm)
F	Overall width	5'-9"	(175 cm)
G	Skip ground clearance when tipped	2'-6"	(76 cm)
H	Overall height tipped	9'-0"	(274 cm)
J	Discharge forward of tyre	2'-0"	(61 cm)
K	Overhang	3'-6 1/2"	(108 cm)
L	Wheeltrack	5'-0"	(152 cm)
M	Prow width	1'-8"	(51 cm)
N	Side discharge distance	10"	(25 cm)

Skip		
Water level	30 cu.ft.	849 Litres
Struck level	34 cu.ft.	963 Litres
Heaped level	43 cu.ft.	1217 Litres
Maximum payload	2 tons 5 cwt	2286 kgms
Hydraulic relief valve set at		
	1750 p.s.i.	123 kg/cm ²
Hydraulic tank capacity		
	6 galls.	27 1/4 Litres
Ground clearance	11 1/2"	29 cm
Turning circle	23'-8"	721 cm

Rear axle articulation	1'-2"	35 cm
Road Speeds at 2000 r.p.m.		
	m.p.h.	km.p.h.
1st	2.48	3.99
2nd	5.76	9.26
3rd	10.66	17.15
Rev.	2.7	4.3

Unladen Weight	
1 ton 18 cwt 3 qtrs	1968 kgms

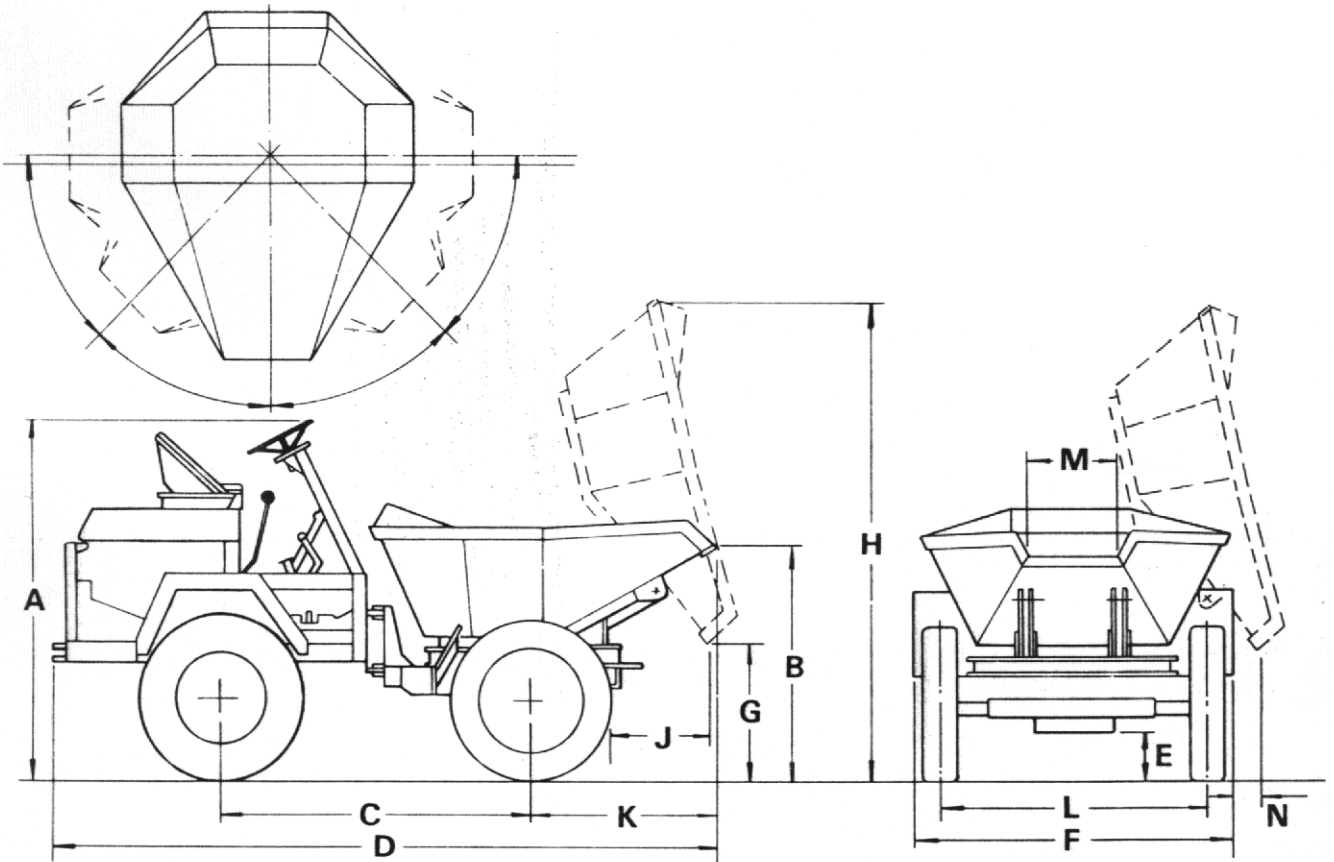

FIG. 4

SPECIFICATION FOR MACHINES WITH TURNTABLE WIDE MOUTH SKIP

A	Overall height	6'-7"	(200 cm)
B	Skip loading height	4'-9"	(145 cm)
C	Wheelbase	5'-7 5/8"	(172 cm)
D	Overall length	12'-5 1/4"	(379 cm)
E	Ground clearance	11 1/2"	(29 cm)
F	Overall width	5'-9"	(175 cm)
G	Skip ground clearance when tipped	2'-6"	(76 cm)
H	Overall height tipped	8'-10 1/2"	(271 cm)
J	Discharge forward of tyre	2' 1"	(63 cm)
K	Overhang	3'-8 1/4"	(112 cm)
L	Wheeltrack	5'-0"	(152 cm)
M	Prow width	3'-6"	(107 cm)
N	Side discharge distance	10 1/2"	(27 cm)

Skip		Rear Axle Articulation		1'-2"	35 cm
Water level	30 cu. ft.	849 Litres	Road Speeds at 2000 r.p.m.		
Struck level	34 cu. ft.	963 Litres		m.p.h.	km.p.h.
Heaped level	43 cu. ft.	1217 Litres	1st	2.48	3.99
Maximum payload	2 tons 5 cwt	2286 kgms	2nd	5.76	9.26
Hydraulic relief valve set at			3rd	10.66	17.15
	1750 p.s.i.	123 kgm/cm ²	Rev	2.7	4.3
Hydraulic tank capacity			Unladen Weight		
	6 gals.	27 1/4 Litres	1 ton 18 cwt. 3 qtrs.		
Ground clearance	11 1/2"	29 cm	1968 kgms.		
Turning circle	23'8"	721 cm			

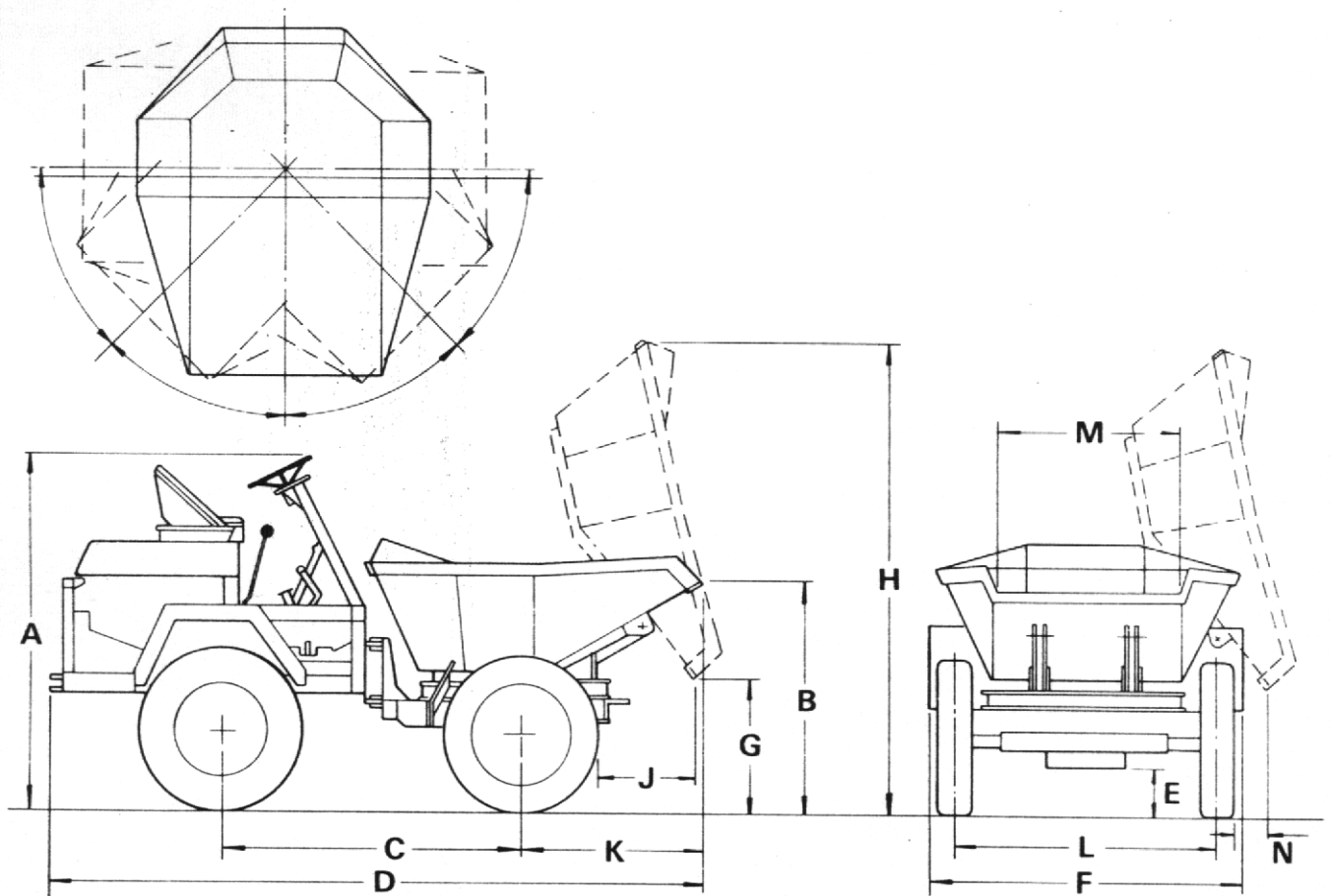

FIG. 5

OPERATION

Starting

(See Fig.2)

1. Lift red-painted overload stop (A) situated on the fuel pump rack above and to the rear of the priming levers (B) and move fuel pump rack (C) into fully-open position.
2. Operate priming levers (B) six times.

NOTE:— This is unnecessary if engine is already warm.

3. Lift decompression lever (D), positioned on top of engine and turn engine as fast as possible using starting handle. When engine is turning at a good speed, knock down decompression lever and engine should fire.
4. If engine does not fire, lift decompression lever and slowly crank engine a few times before attempting to start again. Where ambient temperature is 5° F (–15° C) or below, a cold start aid should be fitted.

Stopping

(See Fig.1)

Pull up stop control knob and hold in its fully raised position until engine stops. Release stop control knob when engine has ceased to turn.

IMPORTANT:

1. DO NOT stop engine by means of decompression levers, this will lead to damaged valve seats and cylinder head joints.
2. DO NOT stop engine by closing fuel tap or by allowing fuel tank to run dry, this will allow air into fuel lines and necessitate bleeding and priming system.

Gear Shift Lever

(See Fig.1)

The Four/45 Dumper is fitted with three forward (1), (2), (3), and one reverse (R) gear. When changing gear, the clutch pedal is used in the normal manner.

Skip Control Lever

(See Fig.1)

1. Control lever has three positions DUMP (A), HOLD (B), and RETURN (C).
2. Push lever forward to DUMP (A) to deposit load.
3. Pull lever back to RETURN (C) to return skip carrying position.

NOTE:— If lever is released when in DUMP or RETURN position, it will automatically return to HOLD (B) position and motion of skip will cease. In this way, speed at which load is deposited can be finely controlled.

Turntable (if fitted)

Pull cranked release lever on turntable catch fully back to release turntable. Revolve skip to required position. To lock in position lift release lock lever and ensure that locking lug locates in turntable locking plate. Cranked release lever will return to its former position.

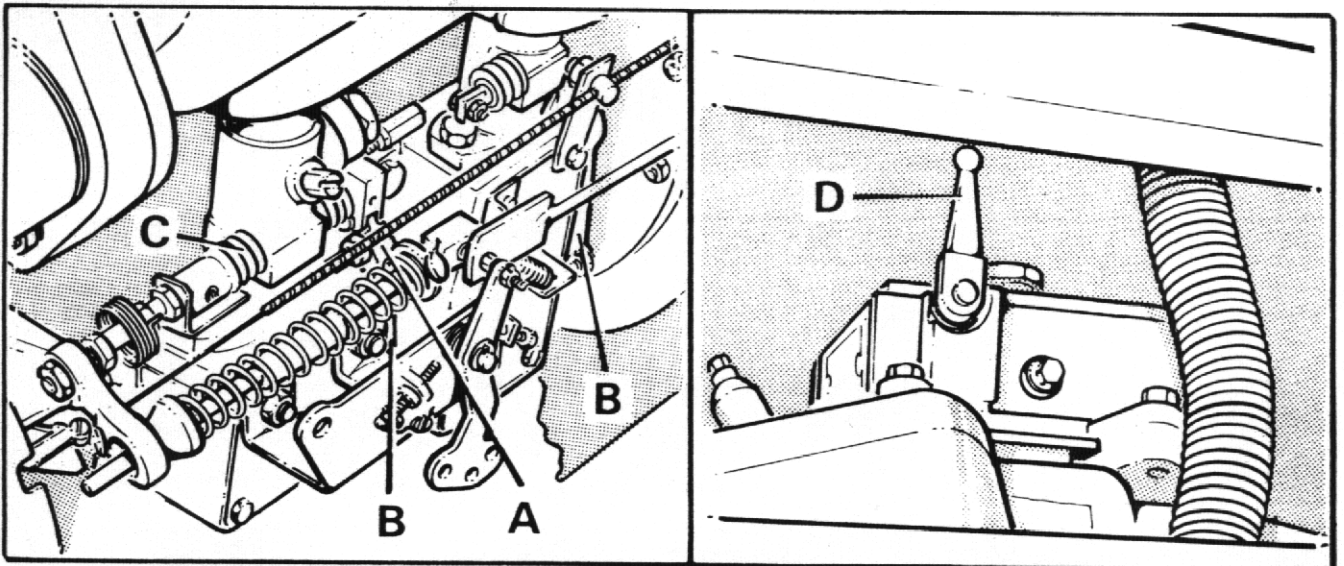

GENERAL MAINTENANCE

Periodic Maintenance

1. DAILY check engine oil level and fill to full mark on dipstick, if necessary.
2. DAILY fill fuel tank, or as often as proves necessary to approximately 1" of top. Never allow there to be a depth of less than 2" of fuel in tank.
3. WEEKLY check oil level in gearbox and fill to full mark on dipstick, if necessary.
4. WEEKLY remove filler/level plugs from drive axles and transfer case. Oil level should be to bottom of holes. Top up, if necessary through filler/level plugs.
5. WEEKLY check oil level in hydraulic tank. Always clean the surrounding area before removing cap to prevent possible entry of foreign matter. Fill tank, if necessary, to within 1" of top.
6. WEEKLY check brake fluid level in master cylinder reservoirs and top up if necessary, to within ¼" of top.
7. WEEKLY apply grease to all grease nipples.
8. WEEKLY check all wheel nuts and tighten, if necessary.
9. WEEKLY check tyre pressures 35 lb/sq.in. (2.46 kgs/cm²)
10. WEEKLY check all nuts and bolts, and tighten if necessary.

Lubrication (See Fig.3)

Period	Key	Description	Lubrication	No. of Points
Daily	1	Engine	Engine Oil	1
	2	Fuel Tank	Diesel Fuel	1
Weekly	3	Gearbox	Gearbox Oil	1
	4	Drive Axles	Axle Oil	2
	5	Hydraulic Tank	Hydraulic Fluid	1
	6	Brake Master Cylinder Reservoirs	Brake Fluid	2
	7	Footbrake Pedal	Grease Gun	1
	8	Accelerator Pedal	Grease Gun	1
	9	Clutch Pedal	Grease Gun	1
	10	Clutch Cross Shaft	Grease Gun	2
	11	Skip Pivot	Grease Gun	2
	12	Handbrake Cable	Grease Gun	1
	13	Chassis Centre Pivot	Grease Gun	2
	14	Prop Shafts & Universal Joints	Grease Gun	10
	15	Transfer Case	Axle Oil	1

N.B. FOR RECOMMENDED LUBRICATING OILS SEE CHART

Oil Capacities

Transfer Box	1pt. (.57 litres)	Drive Axle (HAMWORTHY)	12 pts (6.82 litres)
Gear Box	1½ pts. (.85 litres)	Drive Axle (NEWAGE) . . .	8 pts (4.6 litres)
		Engine	12 pts (6.82 litres)

- NOTES: 1. Rear Axle articulation points consist of bearings that require no lubrication.
 2. For full details of the lubrication and maintenance of the engine refer to Manufacturers Manual.

RECOMMENDED LUBRICATING OILS

COMPANY	ENGINE	NEWAGE DRIVE AXLE	HAMWORTHY DRIVE AXLE	TRANSFER BOX	GEARBOX	WHEEL BEARINGS & OTHER GREASE POINTS	HYDRAULIC SYSTEM
(U.K.) ESSO (Overseas)	ESSOLUBE HDX 20W ESSOLUBE HDX 30 ESSOLUBE HDX 20W ESSOLUBE HDX 10W	TORQUE FLUID 62	IL 2082 IL 2082 IL 2082	GEAR OIL GP 85W/140 GEAR OIL GP 85W/140 GEAR OIL GP 85W/140 GEAR OIL GP 80W	ESSOLUBE HDX 30 ESSOLUBE HDX 30	BEACON 2 BEACON 2	NUTO H32 NUTO H68 NUTO H32 NUTO H22
(U.K.) CASTROL (Overseas)	DEUSOL CRI 20 DEUSOL CRI 30 DEUSOL CRI 20 DEUSOL CRI 10	AGRICASTROL AS AGRICASTROL AS SPECIAL	AGRICASTROL AS AGRICASTROL AS AGRICASTROL MD	DEUSOL EP 90 DEUSOL GEAR EP 140 DEUSOL GEAR EP 90 DEUSOL GEAR EP 80	DEUSOL CRI 30 DEUSOL CRI 30	CASTROL SPHEEROL APT 2 CASTROL SPHEEROL APT 2	CASTROL HYPSPIN AWS 32
(U.K.) SHELL (Overseas)	ROTELLA SX OIL 20/20W ROTELLA SX OIL 30 ROTELLA SX OIL 20/20W ROTELLA SX OIL 10W		DONAX T12 (INITIAL FILL) SPIRAX EP 80 (Top up only) DONAX T12 (INITIAL FILL) SPIRAX EP 80 (Top up only) S.7224 (INITIAL FILL) SPIRAX HD 75 (Top up only)	SPIRAX 90 EP SPIRAX 140 EP SPIRAX 90 EP SPIRAX 80 EP	ROTELLA SX OIL 30 ROTELLA SX OIL 30	RETINAX A RETINAX A	TELLUS OIL 37
(U.K.) BP (Overseas)	VANELLUS M20W VANELLUS M30 VANELLUS M20W VANELLUS M10W		B.P. HYDRAULIC TF-8 B.P. HYDRAULIC TF-8 B.P. TRACTRAN (Top up only)	GEAR OIL SAE 90 EP GEAR OIL SAE 140 EP GEAR OIL SAE 90 EP GEAR OIL SAE 80 EP	VANELLUS M30 VANELLUS M30	ENERGREASE L2 ENERGREASE L2	ENERGOL HLP 65
(U.K.) MOBIL (Overseas)	DELVAC 1220 DELVAC 1230 DELVAC 1220 DELVAC 1210 DELVAC SPECIAL 10W-30	MOBILFLUID 422	MOBIL FLUID 422 MOBIL FLUID 422 MOBIL FLUID 427	MOBILUBE HD 90 MOBILUBE GX 90 MOBILUBE HD 140 MOBILUBE GX 140 MOBILUBE HD 90 MOBILUBE GX 90 MOBILUBE HD 80 MOBILUBE GX 80	DELVAC 1230 DELVAC 1230	MOBILGREASE MP MOBILGREASE SUPER	DTE 24
(Overseas) ALL TEMPERATURES			CENTLUBE F.76 COMPOUND CENTLUBE F.76 COMPOUND CENTLUBE E.76 COMPOUND	CENTURY EP 90 CENTURY EP 140 CENTURY EP 90 CENTURY EP 80	CENTURY ROIL 30 CENTURY ROIL 30	REGULUS A2 REGULUS A2	CENTURY PWL A HYD. OIL CENTURY PWL A HYD. OIL
(U.K.) WALKERS CENTURY (Overseas)	CENTURY ROIL 20W 20 CENTURY ROIL 30 CENTURY ROIL 20W 20 CENTURY ROIL 10W						

IN THE UNLIKELY EVENT OF THE ABOVE OILS NOT BEING AVAILABLE
EQUIVALENT OILS SUPPLIED BY A REPUTABLE MANUFACTURER MAY BE USED

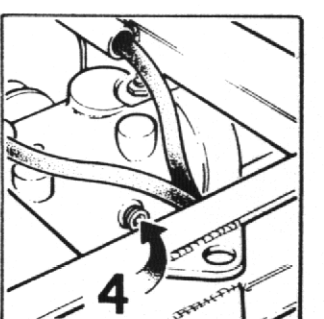
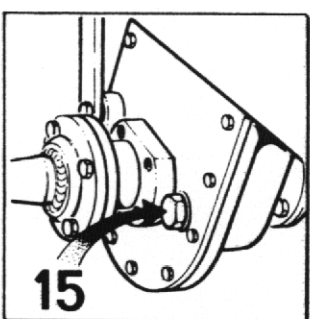
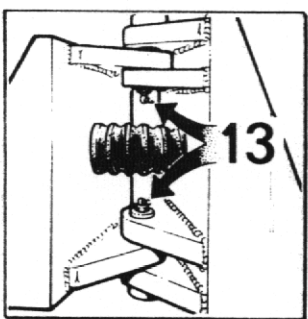
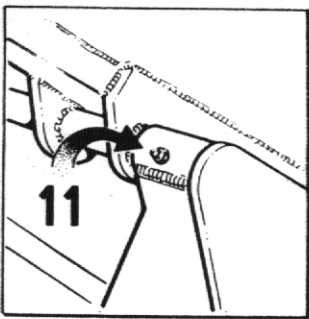
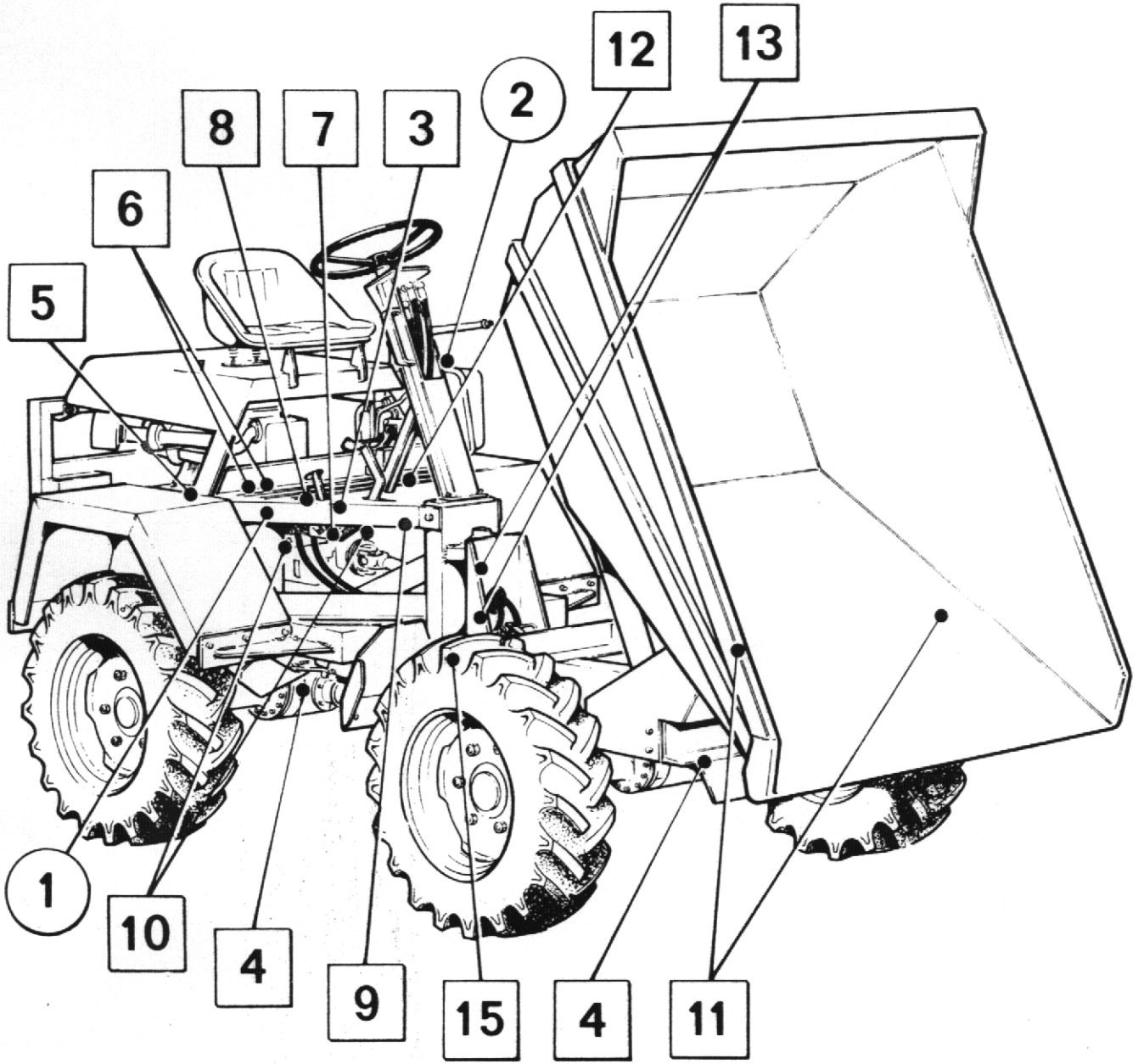
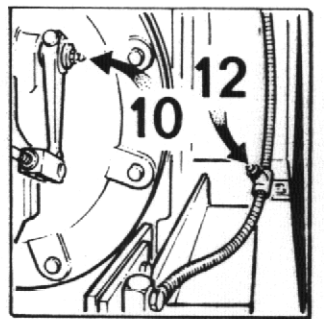
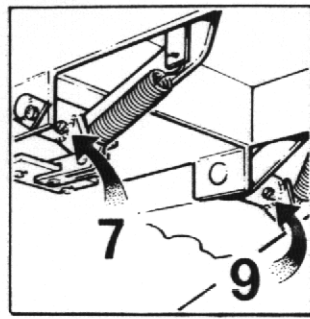
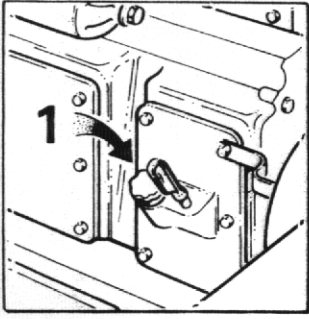

FIG. 7

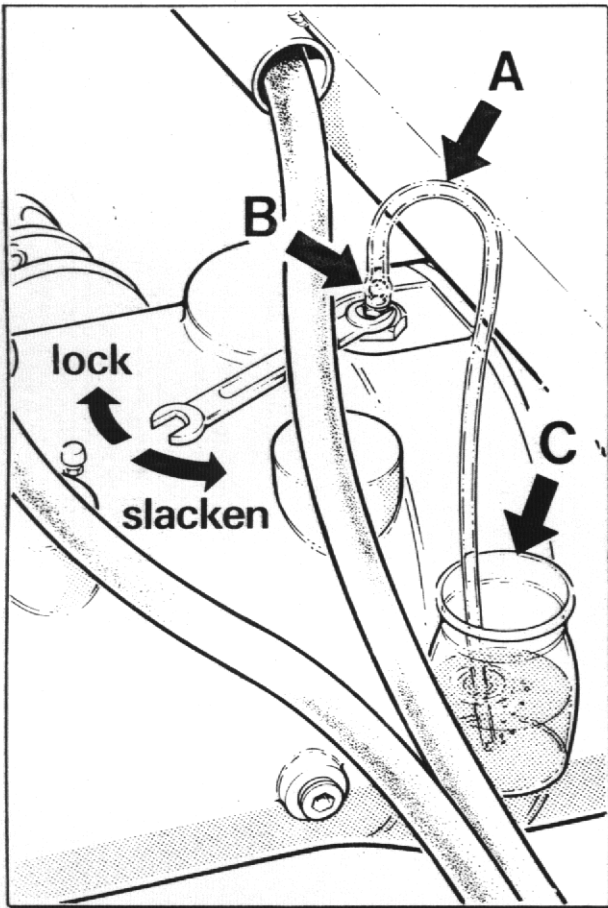

FIG. 8-NEWAGE

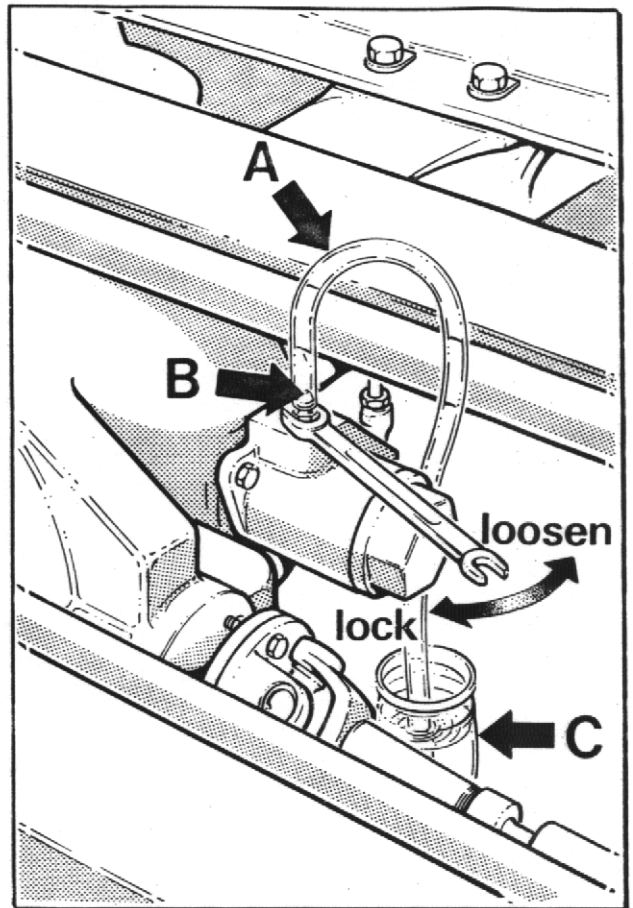

FIG. 8-HAMWORTHY

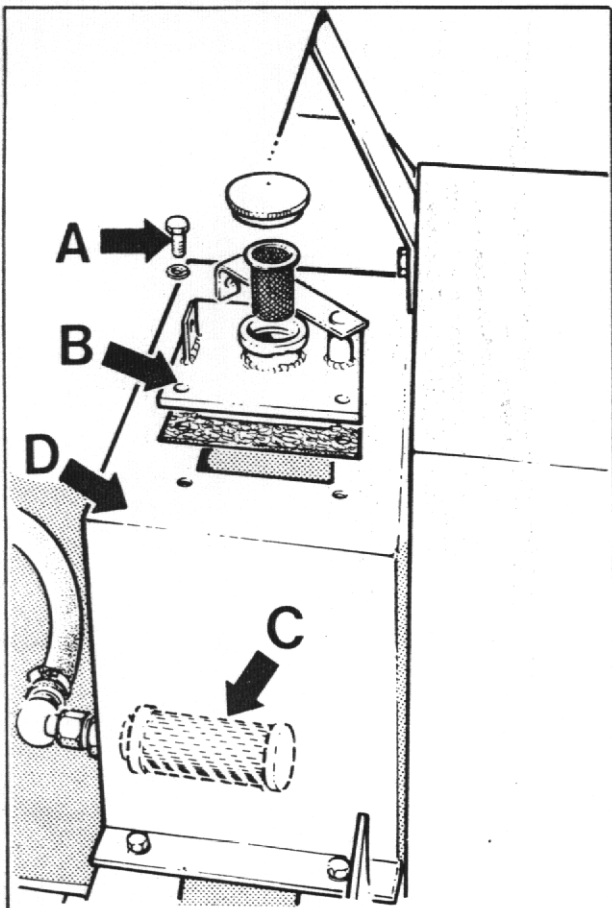

FIG. 9

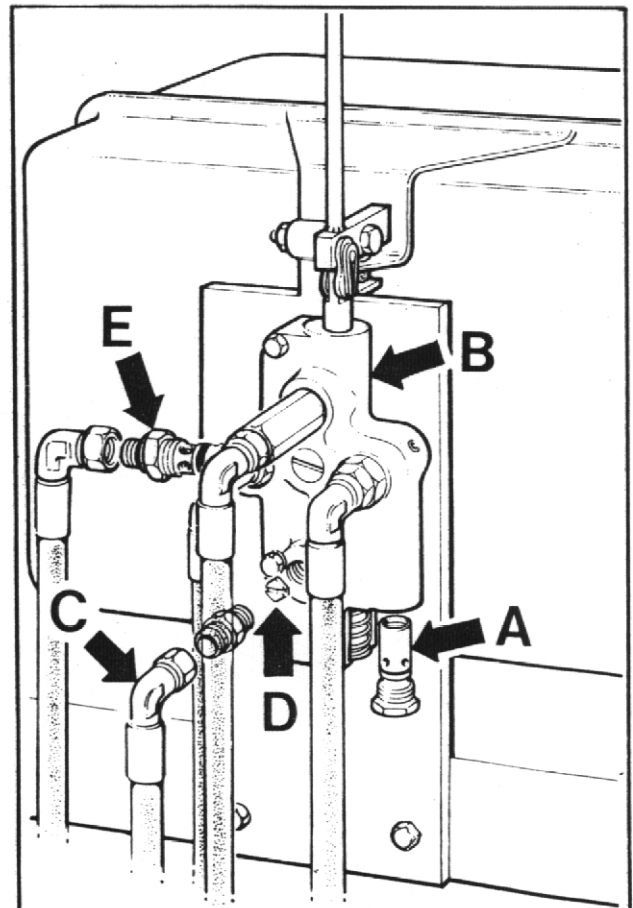

FIG. 10

Brake System

The brake system is designed to require the minimum of maintenance, and, providing the hydraulic fluid in the reservoirs is not allowed to fall below the recommended level, no defects should normally occur. Fluid loss must be supplemented by topping up the reservoirs with brake fluid that conforms to SAE J 1703. No other fluid may be used. If air is present in the system it will be indicated by sluggish response of the brakes and by spongy action of the brake pedal. This may be due to air being introduced at a loose joint or by the reservoir fluid levels being allowed to fall very low. These defects must be remedied immediately and the complete system bled.

To bleed the system, proceed as follows:—

1. Check that all connections are tight and all bleed screws are closed.
2. Fill reservoirs with brake fluid.
3. Attach bleeder tube (A) (See fig. 8) to one of the bleed screws (B) on front axle and immerse other end in a small quantity of brake fluid contained in a glass jar (C). Slacken bleed screw and operate brake pedal up and down to its full stroke, until fluid pumped into the jar contains no air bubbles. Hold down pedal and close bleed screw. Remove bleeder tube and release pedal.
4. Repeat on the other bleed screw on the front axle.
5. Carry out the procedure on the one bleedscrew on the rear axle and continue until all air has been bled from the system.
6. Lock all the bleed screws and top up the reservoirs to the correct level.
7. Apply normal working load on brake pedal for two or three minutes and examine the entire system for leaks.

NOTES: DURING THE OPERATION IT IS ESSENTIAL THAT THE RESERVOIR LEVELS ARE KEPT TOPPED UP TO PREVENT FURTHER AIR BEING DRAWN INTO THE SYSTEM. ONLY USE NEW FLUID FOR TOPPING UP.

ALWAYS ENSURE THAT FREE PLAY EXISTS BETWEEN BRAKE PEDAL AND MASTER CYLINDERS. UNLESS THE PISTONS IN BOTH MASTER CYLINDERS ARE ALLOWED TO FULLY RETURN, BRAKE PRESSURE WILL BUILD UP AND THE BRAKES WILL REMAIN ON.

Hydraulic System

The single hydraulic pump provides power for both the skip operation and steering. The pump output is split into two circuits with priority flow to steering circuit which incorporates a flow control valve. If the hydraulic system fails to operate completely or does so extremely slowly carry out the following procedure.

1. Check that hydraulic tank is full of oil.
2. Check that hydraulic filter is not blocked. (See fig. 9))
 - a) Remove the four setscrews (A) that secure the filler cap assembly (B) and remove assembly.
 - b) Unscrew suction filter (C) from inside tank (D) and wash in white spirit. Dry with moisture-free compressed air.
 - c) Replace suction filter and filler cap assembly.

NOTE:— If suction filter cannot be thoroughly cleaned, fit a new one.

3. Check that the hydraulic pressures are correct.

Tip circuit.

 - a) Fit a 2000 lb/sq.in. gauge into the hydraulic system at the base of the skip ram.
 - b) Operate control lever to dump skip and check that pressure reading on gauge is 1750 lb/sq.in. when ram is fully extended and relief valve is "blowing".

Steering circuit

- a) Fit a 2000 lb/sq.in. gauge into the hydraulic system at the base of the steering ram.
- b) Turn steering wheel with machine on "full lock" and check that the reading on the gauge is 1750 lb/sq.in.

NOTE:— If correct pressure is not attained—

Tip circuit

4. Remove relief valve cartridge (A) (hexagon head) from the bottom of the control valve (B) (See fig. 10) and replace with a new one.
5. Remove hose adaptor (C) from control valve (See Fig. 6), remove hexagonal orifice plate (D) and wash in white spirit. Dry using moisture-free compressed air. DO NOT poke wire etc. into the orifice. Re-fit plate and hose adaptor with slot of orifice plate facing outwards.

Steering circuit

6. Remove relief valve cartridge (A) (hexagon head) from the bottom of the control valve (B) (See fig. 10) and replace with a new one.
7. Replace flow control valve (E) (See fig. 10)

If none of these procedures correct the fault contact your Winget agent. Periodically check the hose between the pump and the tank to ensure it is not deformed. Any deformation in the hose may result in a restricted flow of fluid and damage to the pump.

RELAVENT TO 4/45 C.D.P., FL2500 & 4/60 M/c's FITTED WITH
HAMWORTHY AXLES.
TO ENSURE CORRECT BRAKE OPERATION ASSEMBLE SLAVE CYLINDER
SEALS AS SHOWN BELOW ~

INTERNAL SEAL
(fibre on inside)

EXTERNAL SEAL
(fibre on outside)

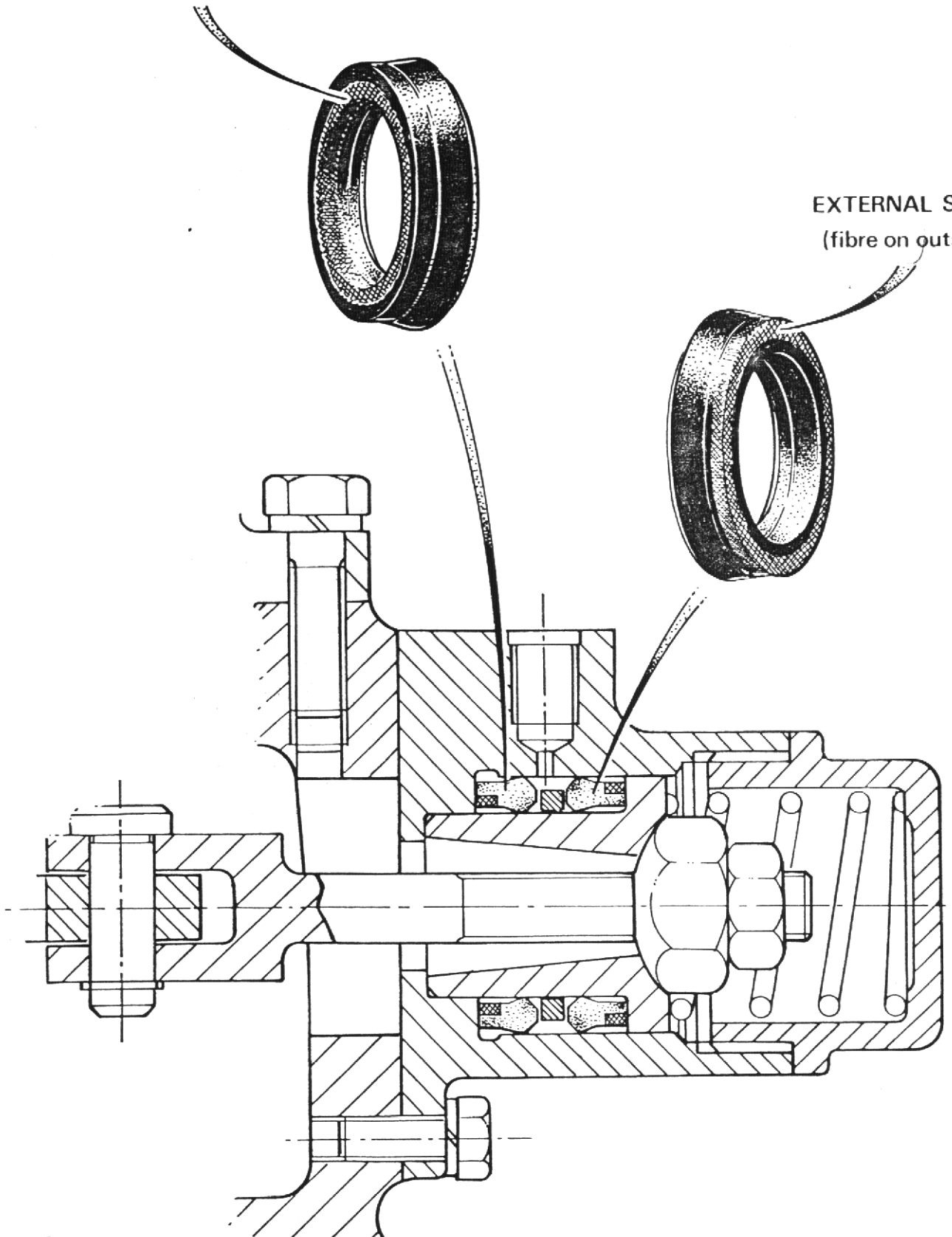

spare parts section

LIST OF CONTENTS

Title	Page No.
CHASSIS	18, 19
MUDWINGS & COVERS.	20, 21
HIGH DISCHARGE SKIP & FRAME	22, 23
TURNTABLE SKIP, FRAME & CATCH.	24, 25
FORWARD TIP SKIP	26
FLYWHEEL & CLUTCH ASSEMBLY	27
GEARBOX	28–31
TRANSFER BOX & PROP SHAFTS	32, 33
DRIVE AXLE (NEWAGE 250 SERIES)	34A–37A
DRIVE AXLE (HAMWORTHY 1000 SERIES)	34B–37B
HANDBRAKE UNIT	38
BRAKE MASTER CYLINDER ASSEMBLY (NEWAGE AXLE M/C's)	39A
BRAKE MASTER CYLINDER ASSEMBLY (HAMWORTHY AXLE M/C's)	39B
BRAKE PIPES & FITTINGS (NEWAGE AXLE M/C's)	40A, 41A
BRAKE PIPES & FITTINGS (HAMWORTHY AXLE M/C's)	40B, 41B
HANDBRAKE, VALVE CONTROL LEVER & ENGINE STOP CONTROL	42, 43
PEDALS & CONTROLS	44, 45
HYDRAULIC PIPES & FITTINGS	46, 47
HYDRAULIC PUMP & DRIVE	48
HYDRAULIC RAM (FWD TIP & TURNTABLE)	49
HYDRAULIC RAM (HIGH DISCHARGE)	50
STEERING RAM	51
HYDRAULIC CONTROL VALVE	52, 53
	54
DRIVE WHEELS & TYRES	55
AIR CLEANER	56

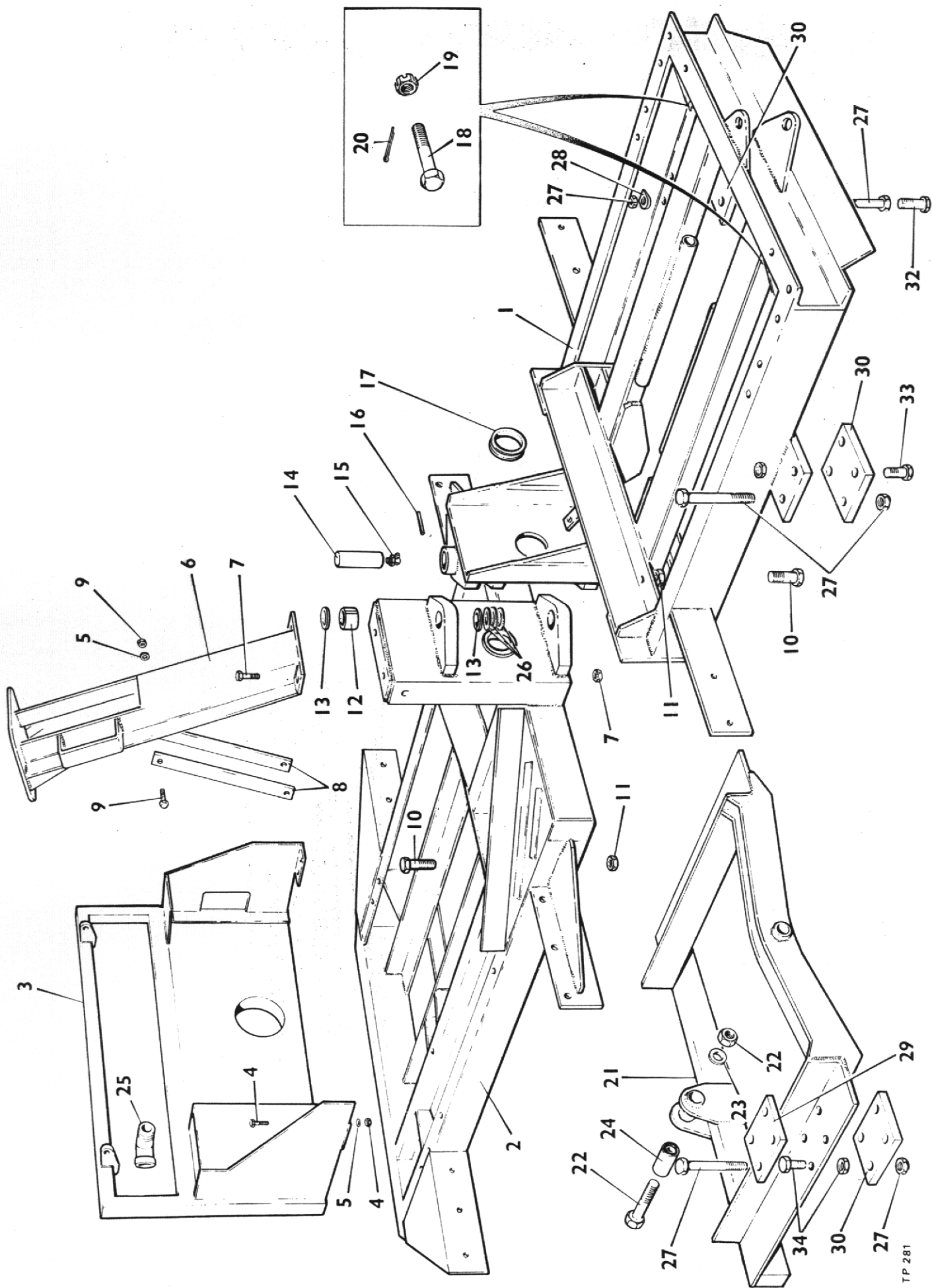

CHASSIS

Item No.	Part No.	Description	Qty.
1	CSE 195	Front Chassis	1
2	CSE 129	Rear Chassis	1
3	CSE 160	Rear Frame	1
4		Bolt M10 x 30mm long & locknut	8
5		Shakeproof Washer 10mm dia	10
6	CSE 107	Steering Column	1
7		Bolt M12 x 45mm long & locknut	2
8	4-35-333	Steering Column Brace	2
9		Bolt M10 x 40mm long & locknut	2
10	4-35-110A	Steering Ram Bolt	2
11	4-35-110B	Steering Ram Nut	2
12	4-35-29B	Centre Pivot Pin Bush	2
13	4-35-29C	Centre Pivot Thrust Washer - Bronze	4
14	4-35-29	Centre Pivot Pin	2
15	T.90	Grease Nipple - 90°	2
16	4-35-29A	Tension Pin 5/16" dia. x 2 1/4" long	2
17	F4-45-182	Grommet	2
18	4-60-104	Skip Ram Bolt (FWD Hydraulic Tip Only)	2
19	4-60-172	Skip Ram Nut (FWD Hydraulic Tip Only)	2
20		Split Pin 3/16" dia. x 2 1/4" long (FWD Hydraulic Tip Only)	2
21	CSE 194	Articulating Frame (Newage Axle Only)	1
	CSE 130	Articulating Frame (Hamworthy Axle Only)	1
22		Bolt M24 x 127mm long & locknut	2
23		Washer 24mm dia.	2
24	MH5236	Articulating Frame Pivot Bush	2
25	CSE 141	Exhaust Elbow 1 1/2" BSP	1
26	ASE 180	Centre Pivot Thrust Washer - M.S. 2 1/2" O.D. x 1 1/2" I.D. x 10 S.W.G.	A/R
	ASE 178	Centre Pivot Thrust Washer - M.S. 2 1/2" O.D. x 1 1/2" I.D. x 14 S.W.G.	A/R
	ASE 179	Centre Pivot Thrust Washer - M.S. 2 1/2" O.D. x 1 1/2" I.D. x 20 S.W.G.	A/R
27	8506 V Bolt 65506 Nut	Bolt M16 x 200 mm long & nut (Newage Axles only)	16
28		Taper Washer 5/8" dia.	4
29	CSE 192	Articulating Frame Stop Plate (Newage Axles only)	2
30	CSE 193	Axle Clamp Plate (Newage Axles Only)	4
31		Bolt M12 x 55mm long & locknut (engine mtg.)	4
32		Bolt M16 x 75mm long & locknut (Hamworthy Axles Only)	4
33		Bolt M16 x 60mm long & locknut (Hamworthy Axles Only)	4
34		Bolt M16 x 45mm long & locknut (Hamworthy Axles Only)	8

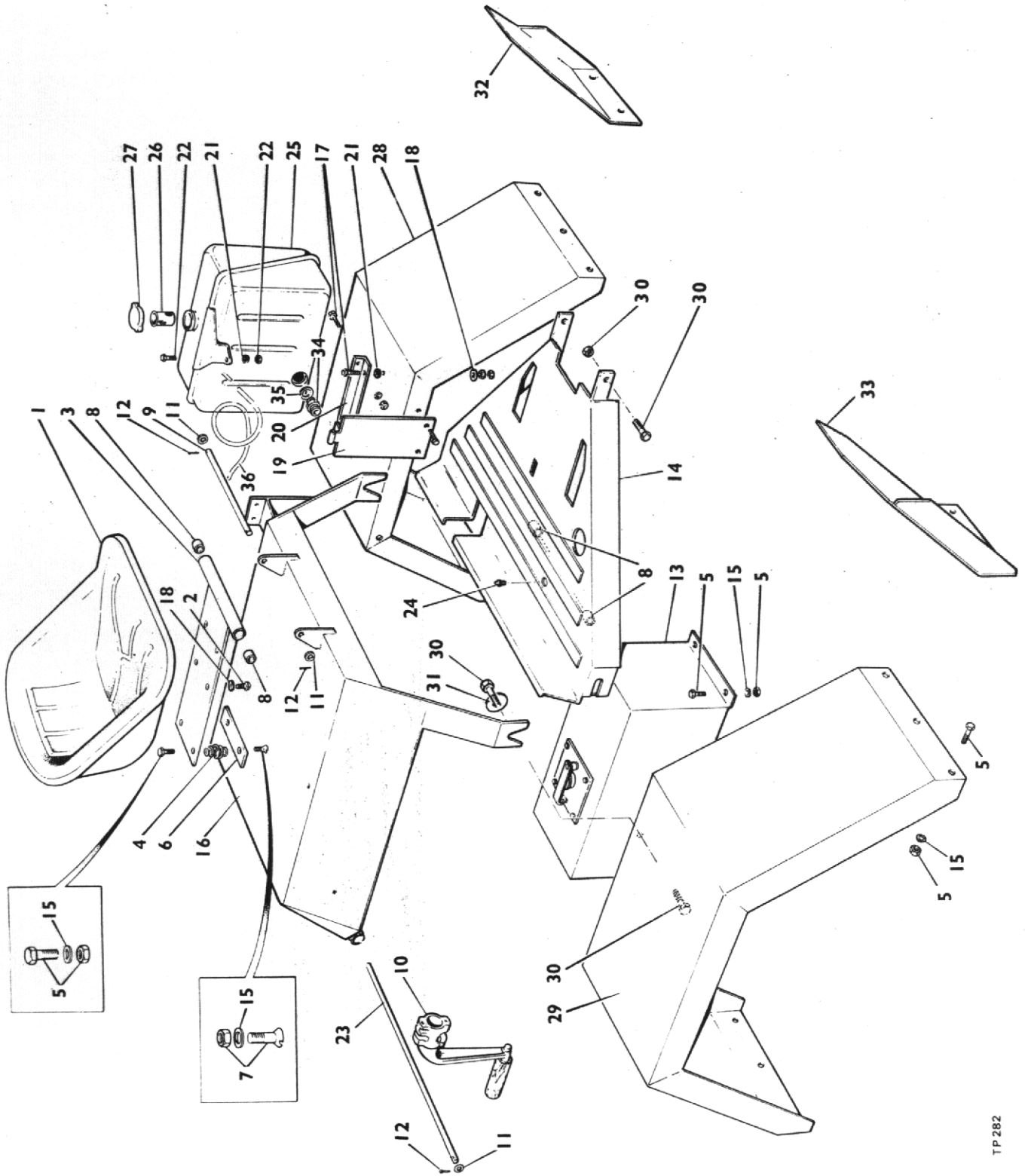

MUDWINGS AND COVERS

Item No.	Part No.	Description	Qty.
1	4-35-301	Seat	1
2		Seat Bolts 8mm x 20mm long Mushroom Head	4
3	CSE 116	Seat Frame	1
4	5ST 99	Seat Spring	2
5		Bolt M10 x 25mm long & locknut	22
6	4-35-331	Seat Spring Plate	1
7		Bolt csk. M10 x 25mm long & locknut	2
8	WB0808	Bush	4
9	4-35-307	Seat Pivot Rod	1
10	C188	Starting Handle	1
11		Flat Washer 12mm dia.	4
12		Split Pin 3/32" dia x 1" long	4
13	CSE 123	Hydraulic Tank (See Page 47)	1
14	CSE 191	Footplate (fitted only on m/c's with Newage Axles)	1
	CSE 151	Footplate (fitted only on m/c's with Hamworthy Axles)	1
15		Flat Washer 10mm dia.	24
16	CSE 161	Engine Cover	1
17		Bolt M8 x 25mm long & locknut	4
18		Flat Washer 8mm dia	6
19	F4-45-173	Hydraulic valve mounting Bracket (See Page 43)	1
20	CSE 170	Angle	1
21	CSE 158	Rubber bush	3
22		Bolt M6 x 30mm long and locknut	1
23	CSE 168	Pivot Pin	1
24	T-ST	Grease Nipple	1
25	BAE 7E	Fuel Tank	1
26	JE 13	Strainer	1
27	CE 12	Cap	1
28	F4-45-181	Left Hand Mudwing Assembly	1
29	CSE 187	Right Hand Mudwing	1
30		Bolt M12 x 40mm long & locknut	6
31	CSE 167	Blanking Plate	2
32	4-35-390	Left Hand Mudflap	1
33	4-35-389	Right Hand Mudflap	1
34	4-60-189	Adaptor 3/8 in. BSP x 1/4 in. BSP	1
35	4-35-364	Fibre Washer	1
36	258721	Leak back tube 18 in.	1

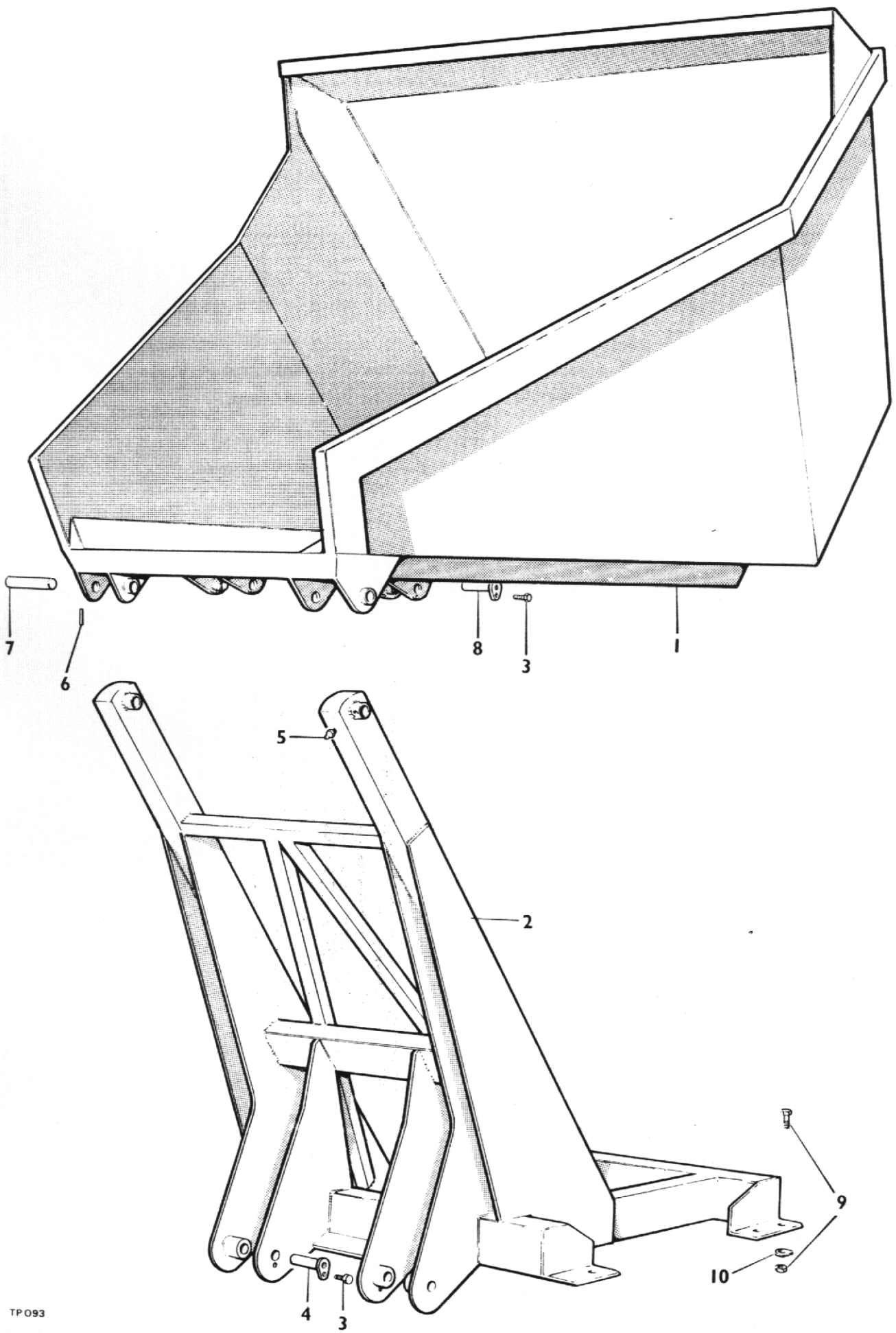

HIGH DISCHARGE SKIP AND FRAME

Item No.	Part No.	Description	Qty.
1	4-35-210	Skip	1
2	4-35-323	Frame	1
3		Bolt M8 x 20mm long & locknut	4
4	4-35-226	Lower Ram Pin	2
5	5ST 100	Grease Nipple	2
6	4-35-29A	Tension Pin 5/16" dia. x 2 1/4" long	2
7	5ST 84	Skip Pivot Pin	2
8	4-35-178	Ram Pin	2

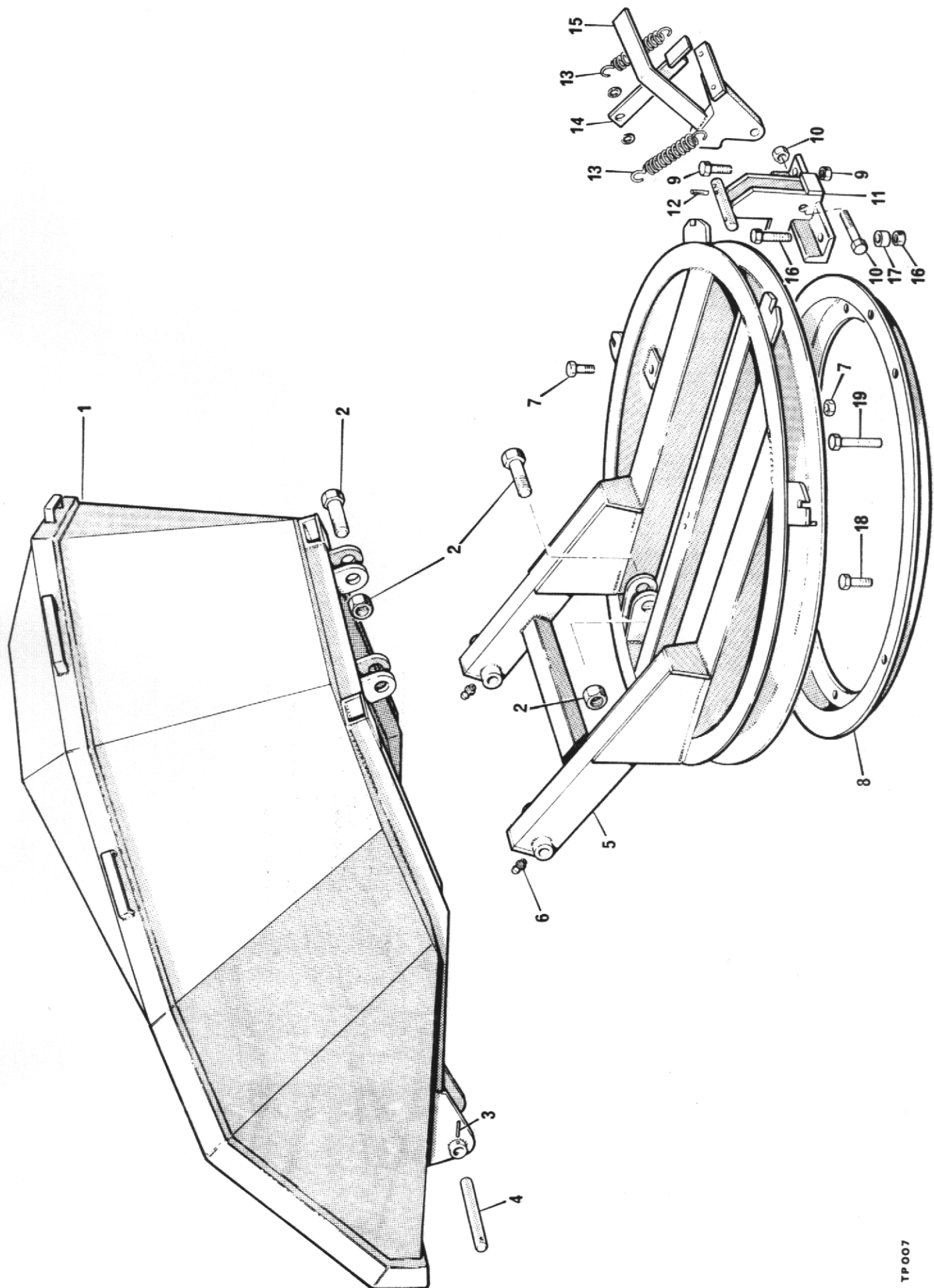

TURNTABLE SKIP, FRAME AND CATCH

Item No.	Part No.	Description	Qty.
1	5ST 79	Narrow Mouth Skip	1
	5ST 97	Wide Mouth Skip	1
2	4-35-110	Ram Bolt & Nut	4
3	4-35-29A	Tension Pin 5/16" x 2 1/4" long	2
4	5ST 84	Skip Pivot Pin	2
5	5ST 78	Turntable	1
6	5ST 100	Grease Nipple	2
7		Bolt M12 x 35mm long & locknut	4
8	5ST 69	Turntable ring	1
9		Bolt M12 x 40mm long & locknut	1
10		Bolt M16 x 55mm long & locknut	1
11	4-35-319-12	Turntable Catch Body	1
12	C129A	Tension Pin 3/16" dia. x 1 1/4" long	1
13	4-35-320	Spring	2
14	4-35-319-4	Locking Bar	1
15	4-35-319-13	Catch Plate	1
16		Bolt M12 x 55mm long & locknut	1
17	4-35-327	Packing Piece 7/8" dia. 1/2" Bore x 5/8" long	1
18		Bolt M12 x 45mm long & locknut	4
19		Bolt M12 x 105mm long & locknut	4
20	4-35-319	Turntable Catch Assembly (Complete)	1
		(Not Illustd.)	1

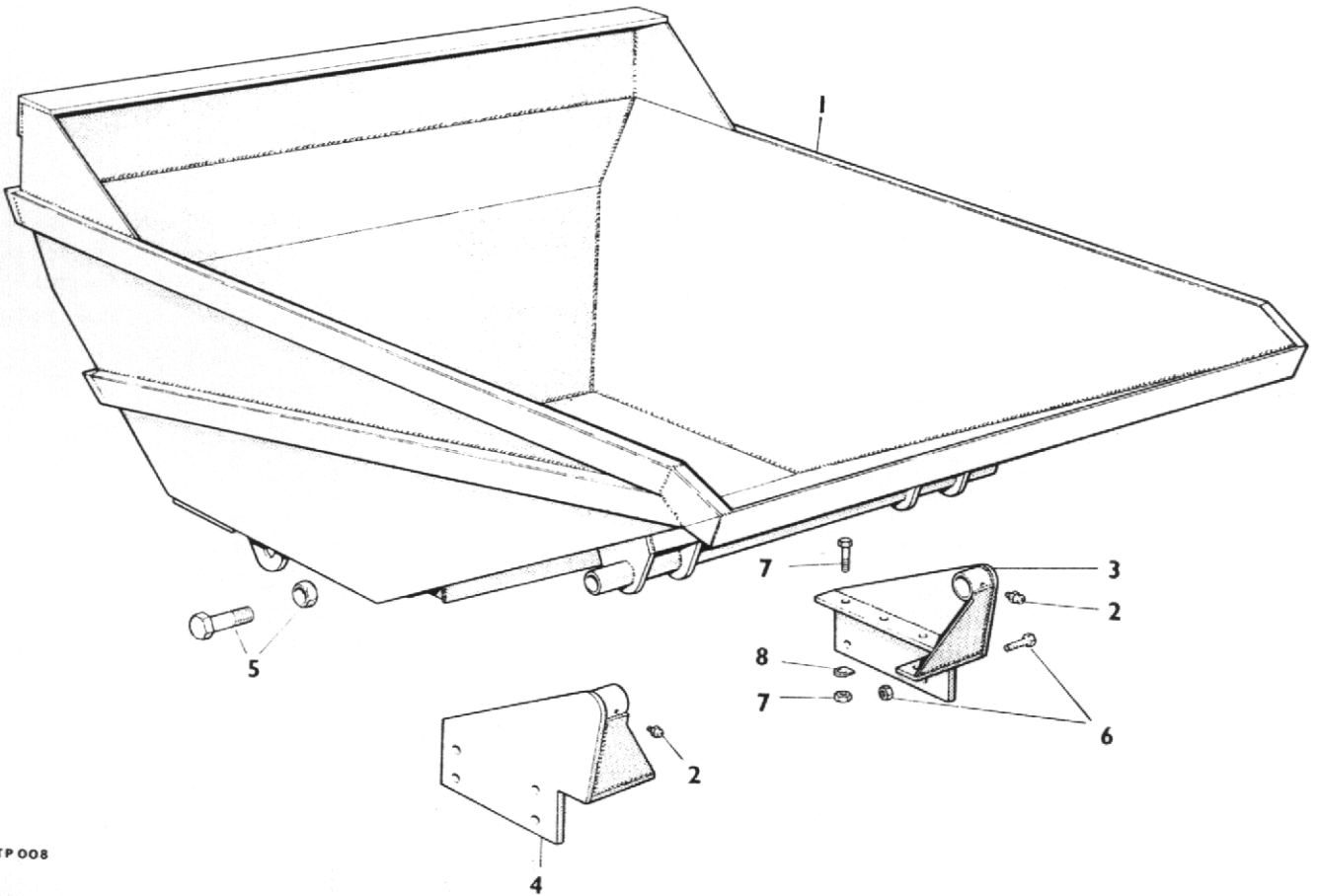

FORWARD TIP SKIP

Item No.	Part No.	Description	Qty.
1	4-35-302	Skip	1
2	5ST 100	Grease Nipple	2
3	4-35-309	Skip Mtg. Brkt. L.H.	1
4	4-35-308	Skip Mtg. Brkt. R.H.	1
5	4-35-110	Ram Bolt & Nut	2
6		Bolt M12 x 40mm long & locknut	8
7		Bolt M12 x 45mm long & locknut	10
8		Taper Washer 1/2" dia.	10

FLYWHEEL AND CLUTCH ASSEMBLY

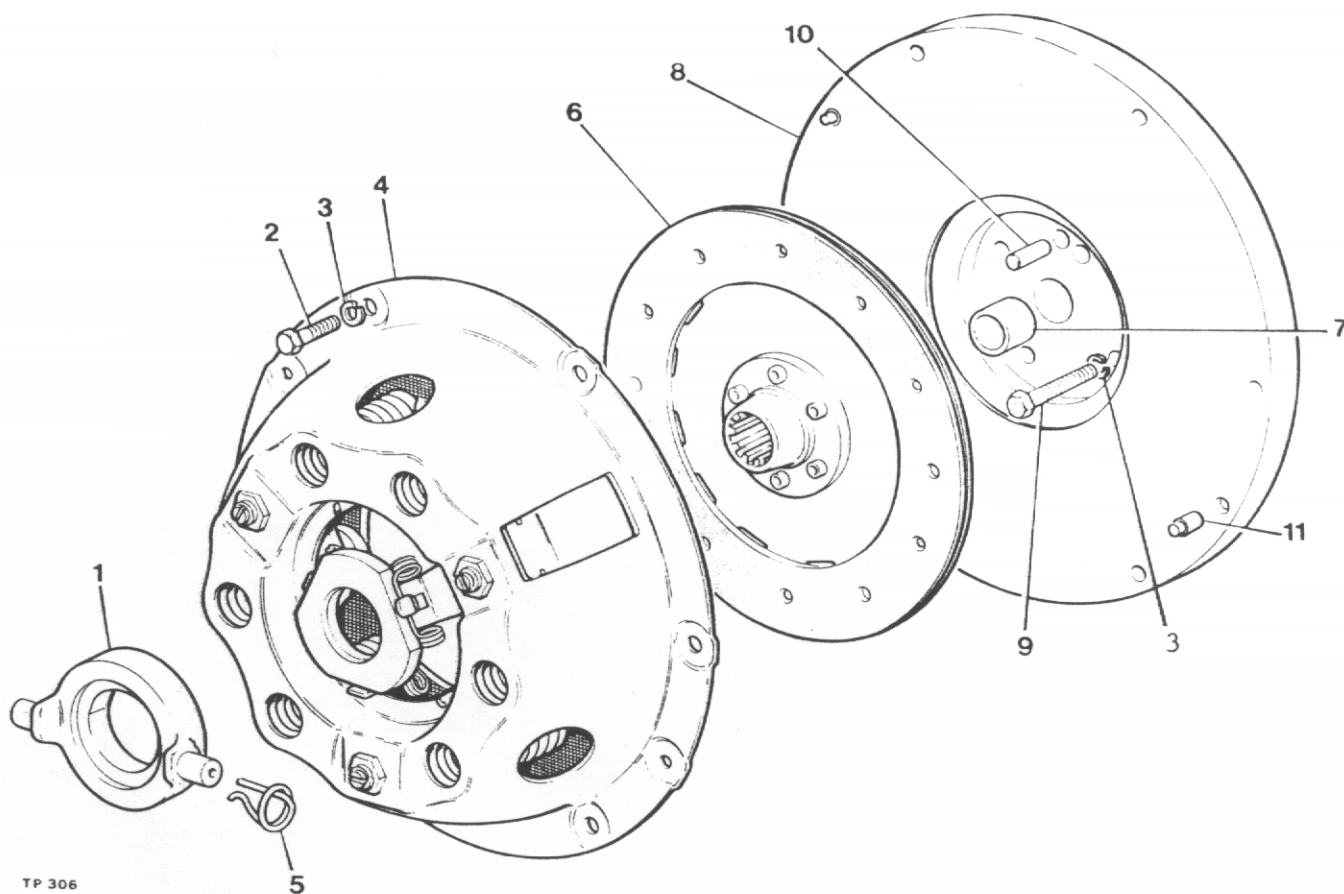

TP 306

Item No.	Part No.	Description	Qty.
1	10579A01	Clutch Release Bearing	1
2	28S02D	Screw Set	6
3	41S04	Washer Spring	10
4	10597A01	Cover Assembly	1
5	10579A101	Retainer Spring	2
6	10598A02	Drive Plate	1
7	10580A0101	Bush	1
8	10580A02	Flywheel Assembly (comprises of items 7, 8, & 11)	1
9	1S02C	Bolt, Petter PH Engine (drill for locking wire)	4
9A	6S02B	Bolt, Lister Engine (drill for locking wire)	4
10	C321	Dowel	1
11	10580A0102	Dowel	2
	10948A02	Clutch Kit (comprises of items 1, 4, 5 & 6)	1

It is recommended that instead of drilling the head of the bolts (item 9) for locking wire that one of each of tabwashers part no's 10531A02 and 10531A03 are used to prevent the bolts working loose.

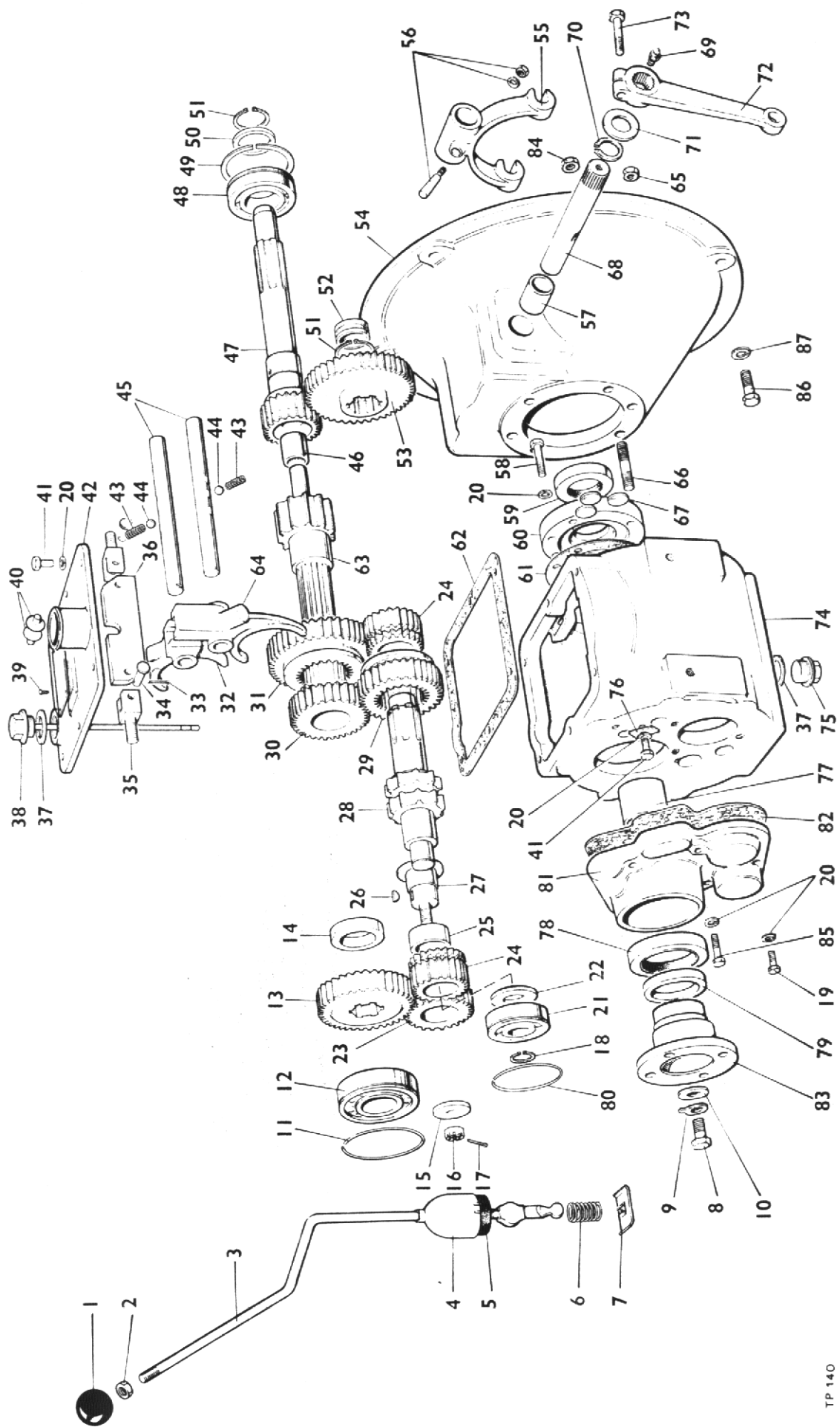

GEARBOX (40M-2-589 INV. 372)

Item No.	Part No.	Description	Qty.
1	40M-133	Gear Lever Knob	1
2	UN512	Gear Lever Locknut	1
3	40M 372	Gear Lever	1
4	40M-377	Gear Lever Cap	1
5	40M-129	Gear Lever Cover	1
6	40M-367	Gear Lever Spring	1
7	40M-245	Gear Lever Retaining Plate	1
8	USF 55	Bolt	1
9	CM2050	Tab Washer	1
10	CM2123	Washer	1
11	CM2060	Snap Ring	1
12	CM2052	Bearing, Mainshaft Rear	1
13	40M-110	Output Gear	1
14	40M-128	Output Gear Spacer	1
15	40M-155	Reverse Pinion Shaft Washer	1
16	UN507	Reverse Spindle Nut	1
17	CP1004	Split Pin	1
18	40M-148	Circlip	1
19	USF 31	Bolt	3
20	W104	Spring Washer	17
21	40M-146	Layshaft bearing	1
22	40M-130	Bearing spacer	1
23	40M-111	Reverse pinion	1
24	40M-114	Reverse speed gear	2
25	40M-161	Reverse pinion bush	1
26	40M-222	Reverse pinion shaft key	1
27	40M-119	Reverse pinion shaft	1
28	40M-118	Layshaft	1
29	40M-116	2nd. Speed sliding gear	1
30	40M-113	Second speed gear	1
31	40M-115	1st Speed gear	1
32	40M-502	2nd. and 3rd. Selector fork	1
33	40M-244	Split pin, interlock	2
34	40M-232	Clevis pin, interlock	2
35	40M-231	Stud, interlock	2
36	40M-505	Interlock plate	1
37	CP-1068	Sealing washer	2
38	40M-153	Dipstick	1
39	CP 1003	Drive screw	4
40	40M-254	Gear lever pad	2
41	USF 21	Bolt	7
42	40M-220	Top cover	1
43	CM 2103	Detent spring	2
44	CM 1077	Detent ball	2
45	40M-135	Selector shaft	2
46	40M-513	Bearing, Primary shaft	1
47	40M-117	Primary shaft	1

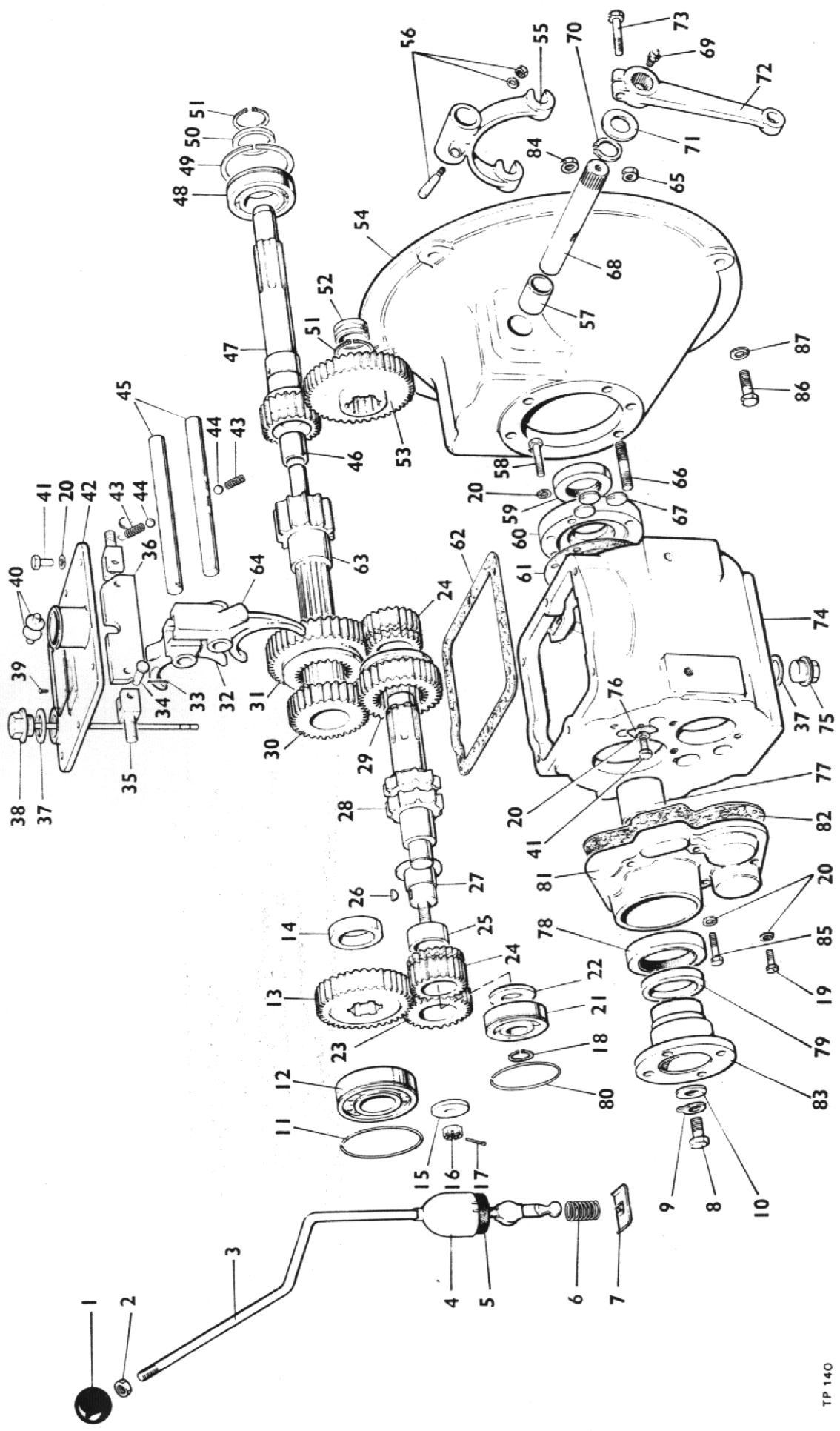

GEARBOX (CONT'D)

Item No.	Part No.	Description	Qty.
48	40M-143	Input bearing	1
49	40M-252	Snap ring	1
50	40M-174	Bearing spacer	1
51	CM2053	Circlip	2
52	40M-162	Layshaft bush	1
53	40M-360	1st. Reduction gear	1
54	40M-392	Clutch housing	1
55	CM2083	Clutch release fork	1
56	CM2084 S/A	Cotter, nut and washer S/A	1
57	CM2179	Cross shaft bush	2
58	UBF 71	Front cover bolt	4
59	40M-150	Oil seal, input	1
60	40M-126	Front cover	1
61	40M-172	Front cover gasket	1
62	40M-169	Top cover gasket	1
63	40M-514	Mainshaft	1
64	40M-501	1st. and reverse selector fork	1
65	UN501	Clutch lever nut	1
66	40M-177	Clutch housing stud	6
67	CM2113	Welch plug	3
68	40M-394	Clutch cross shaft	1
69	CP 1069	Grease nipple	2
70	CP 1006	Circlip	1
71	40M-398	Cross shaft washer	1
72	CM 2090	Clutch release lever	1
73	UBF 91	Clutch lever bolt	1
74	40M 101-B	Gearcase	1
75	CP 1189	Drain plug	1
76	40M-136	Selector locking strip	1
77	40M-138	Spacer	1
78	40M-167	Rear oil seal	1
79	CM 2537	Dust shield	1
80	40M-203	Snap ring	1
81	40M-107	Output cover	1
82	40M-171	Output cover gasket	1
83	40M-589	Coupling	1
84	UN516	Nut (Clutch housing)	6
85	USF 51	Bolt	2
86		Bolt 3/8" BSF x 1" long	6
87		Springwasher 3/8" dia.	6

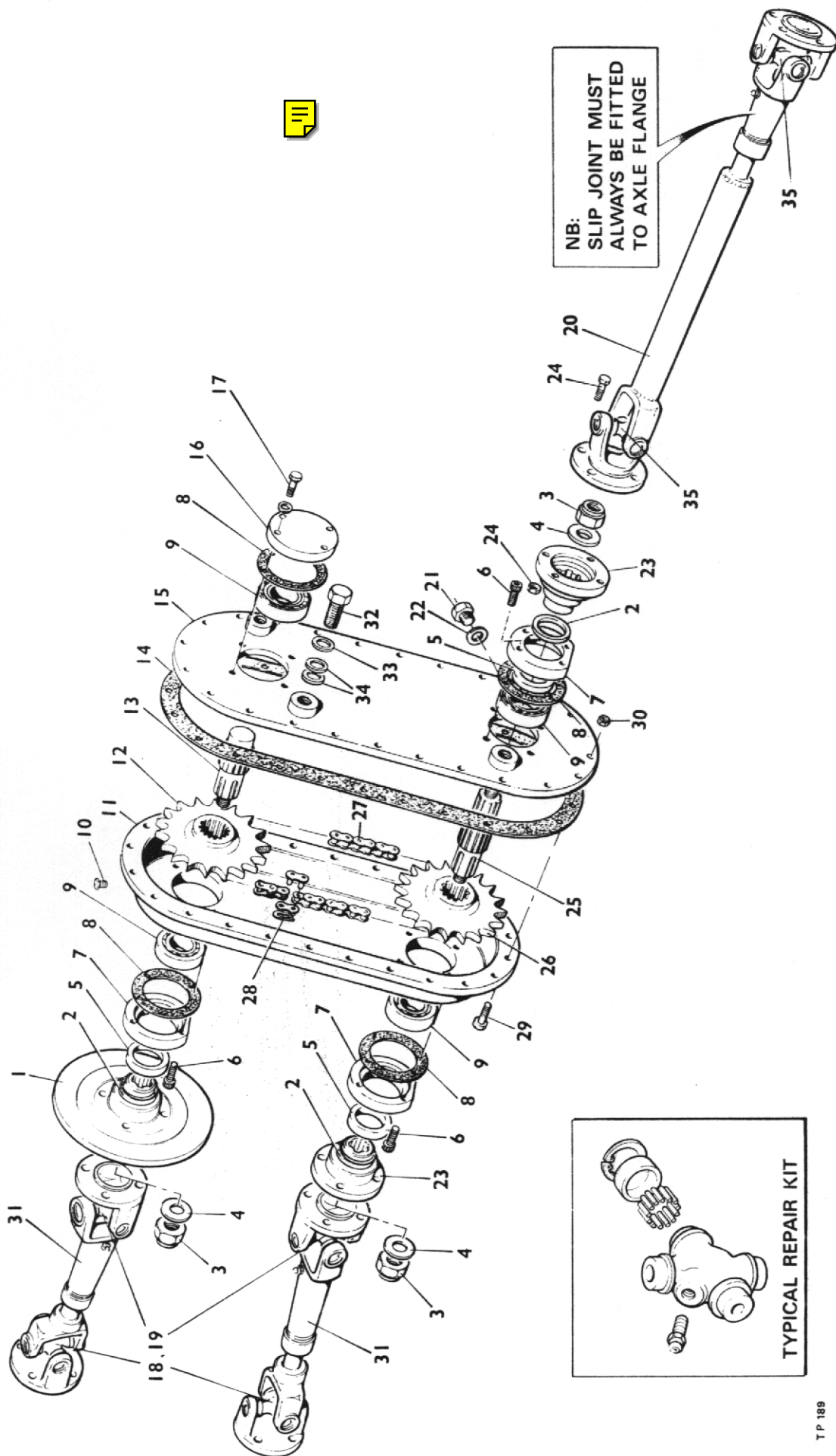

NB:
SLIP JOINT MUST
ALWAYS BE FITTED
TO AXLE FLANGE

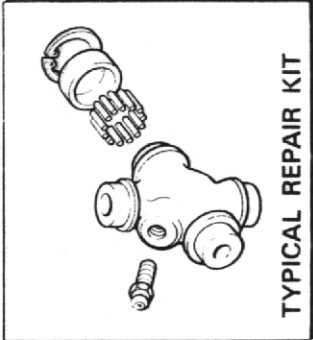

TRANSFER BOX AND PROP SHAFTS

Item No.	Part No.	Description	Qty.
	CSE 201	Transfer Box (13/19 Teeth) Complete with disc	1
1	CSE 164	Brake Disc (222mm dia)	1
2	CM 2537	Dust Shield	3
3	UN 580	Self Locking Nut 3/4" UNF	3
4	CP 1264	Thick Washer 3/4" dia.	3
5	40M-167	Oil Seal	3
6	UFC 416	Cap Screw	12
7	4-35-102	Oil Seal Housing	3
8	CM 2073	Gasket	4
9	CM 2068	Bearing	4
10	CM 2106	Breather	1
11	4-35-96	Main Case	1
12	ASE 175	Chain Wheel (13 Tooth)	1
13	4-60-252	Input Shaft	1
14	4-35-20	Gasket	1
15	4-35-381	Main Case Cover	1
16	CM 2528	End Cover	1
17	UBF 51	End Cover Screws	4
18	K-5-GB-18	Repair Kit	4
19	94-GB-2459	Grease Nipple	4
20	CSE 146	Prop Shaft	1
21	CP 1189	Level/Filler Plug	1
22	CP 1068	Fibre Washer	1
23	40M 589	Companion Flange	2
24		Bolt, 7/16" BSF x 1 1/4" long & Nut	24
25	4-60-253	Output Shaft	1
26	4-35-17	Chain Wheel (19 Tooth)	1
27	ASE 176	Drive Chain (13/19 Teeth)	1
28	4-35-18A	Chain Connecting Link	2
29	UBF 71	Housing Screw	24
30	UN 501	Nut	24
31	1350 YSA	Prop Shaft Assembly	2
32		Bolt 1/2" BSF x 1 1/4" long (drilled for Wire Locking)	3
33		Flat Washer 1/2" dia.	3
34		Flat Washer 1/2" dia.	A.R.
35	CSE 202	Repair Kit	A.R.

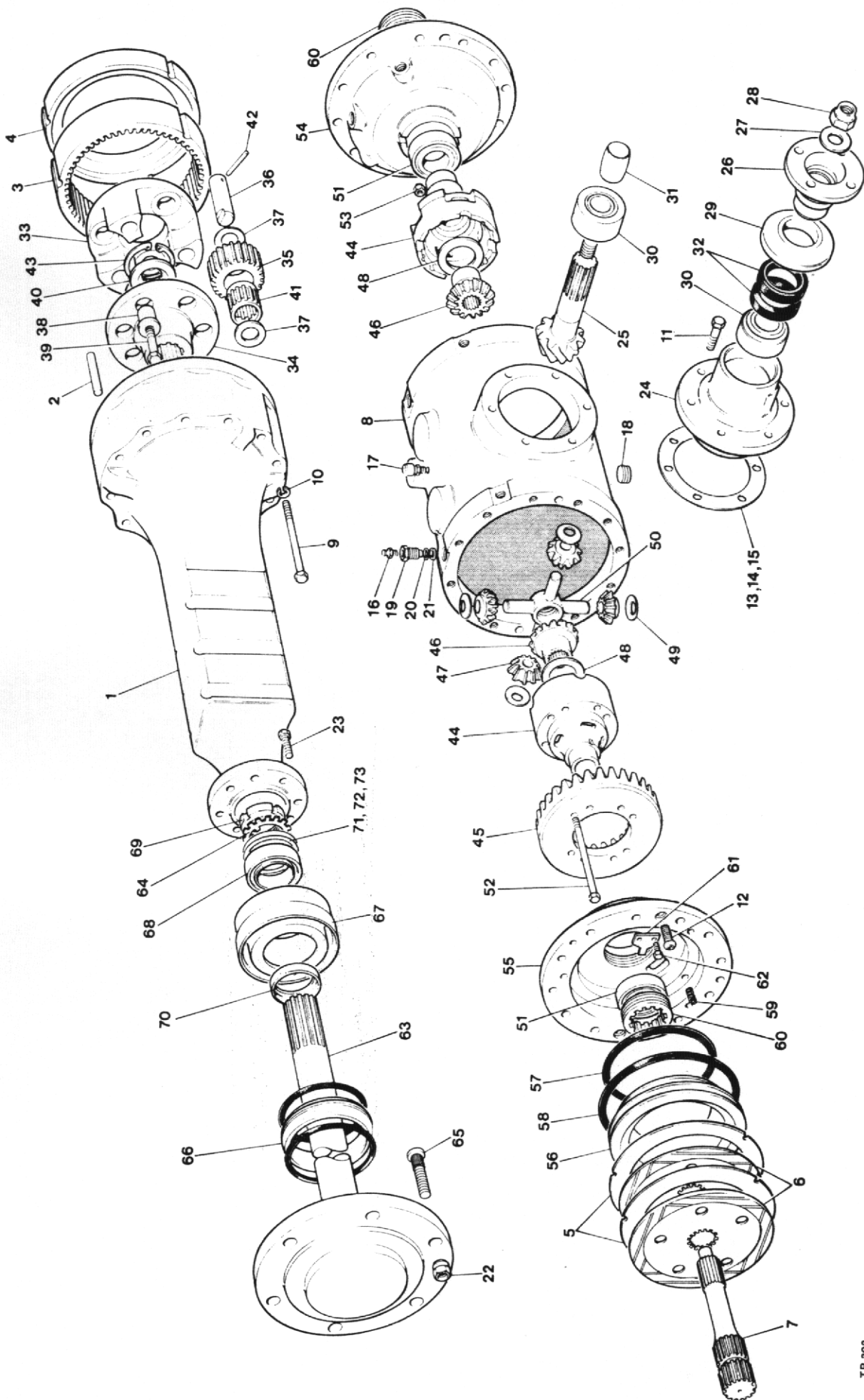

**DRIVE AXLE
(250 SERIES)**

Item No.	Part No.	Description	Qty.
1	250-0020	Axle Arm	2
2	010-0060	Pin	6
3	250-0070	Annulus	2
4	253-0880	Brake Spacer Plate	2
5	250-0890	Brake Fixed Plate	2
6	250-0750	Oil Immersed Brake Disc	2
7	250-0090	Sun Gear	2
8	257-0011	Main Axle Casing	1
9	004-0090	Bolts - Main Axle Casing	24
10	009-0010	Spring Washer	24
11	012-0030	Hex. Screw	6
12	006-0280	Hex. Socket Button Head Screw	4
13	250-2350	Pinion Adjuster Shim (0.25 Thick)	A/R
14	250-2290	Pinion Adjuster Shim (0.075 Thick)	A/R
15	250-2210	Pinion Adjuster Shim (0.050)	A/R
16	008-0090	Brake Bleed Valve	2
17	008-0070	Relief Valve 1/8" BSP	1
18	008-0020	Hex. Socket BSPT Plug - 3/4" BSPT	2
19	400-1070	Brake Pipe Adaptor	4
20	002-0200	'O' Ring	4
21	009-0100	Dowty Washer	4
22	CSE 197	Wheel Nut	12
23	012-0030	Hex. Screw	16
24	250-2300	Input Pinion Cartridge	1
25	250-2000	Spiral Bevel Pinion	1
26	250-2180	Drive Flange	1
27	009-0090	Drive Flange Washer	1
28	007-0130	Drive Flange Nut	1
29	250-0910	Oil Seal Cover	1
30	001-0110	Pinion Bearing	2
31	250-1050	Pinion Bearing Spacer	1
32	002-0030	Pinion Oil Seal	2
33	250-0060	Planet Carrier	1
34	250-0260	Carrier Drive Flange	1
35	250-0080	Planet Gear	3
36	250-0250	Planet Pins	3
37	250-0270	Planet Thrust Washer	6
38	250-0370	Planet Carrier Bush	3
39	012-0070	Planet Carrier Bolt	3
40	250-1320	Axle Shaft Thrust Spacer	1
41	001-0160	Planet Cage Roller	3
42	010-0070	Spring Dowel	3
43	003-0140	Circlip	1
44	250-9520	Diff. Case Process Assembly	1
45	250-2010	Spiral Bevel Wheel	1
46	250-2090	Diff. Wheel	2
47	250-2100	Diff. Pinion	4
48	250-2110	Diff. Wheel Thrust Washer	2
49	250-2120	Diff. Pinion Thrust Washer	4
50	250-2130	Diff. Spider	1
51	001-0100	Diff. Bearing	2
52	004-0090	Bolts	8
53	007-0100	Nyloc Nuts	8
54	253-0761	Brake Cylinder (R.H.)	1
55	253-0771	Brake Cylinder (L.H.)	1
56	250-0780	Brake Piston	2

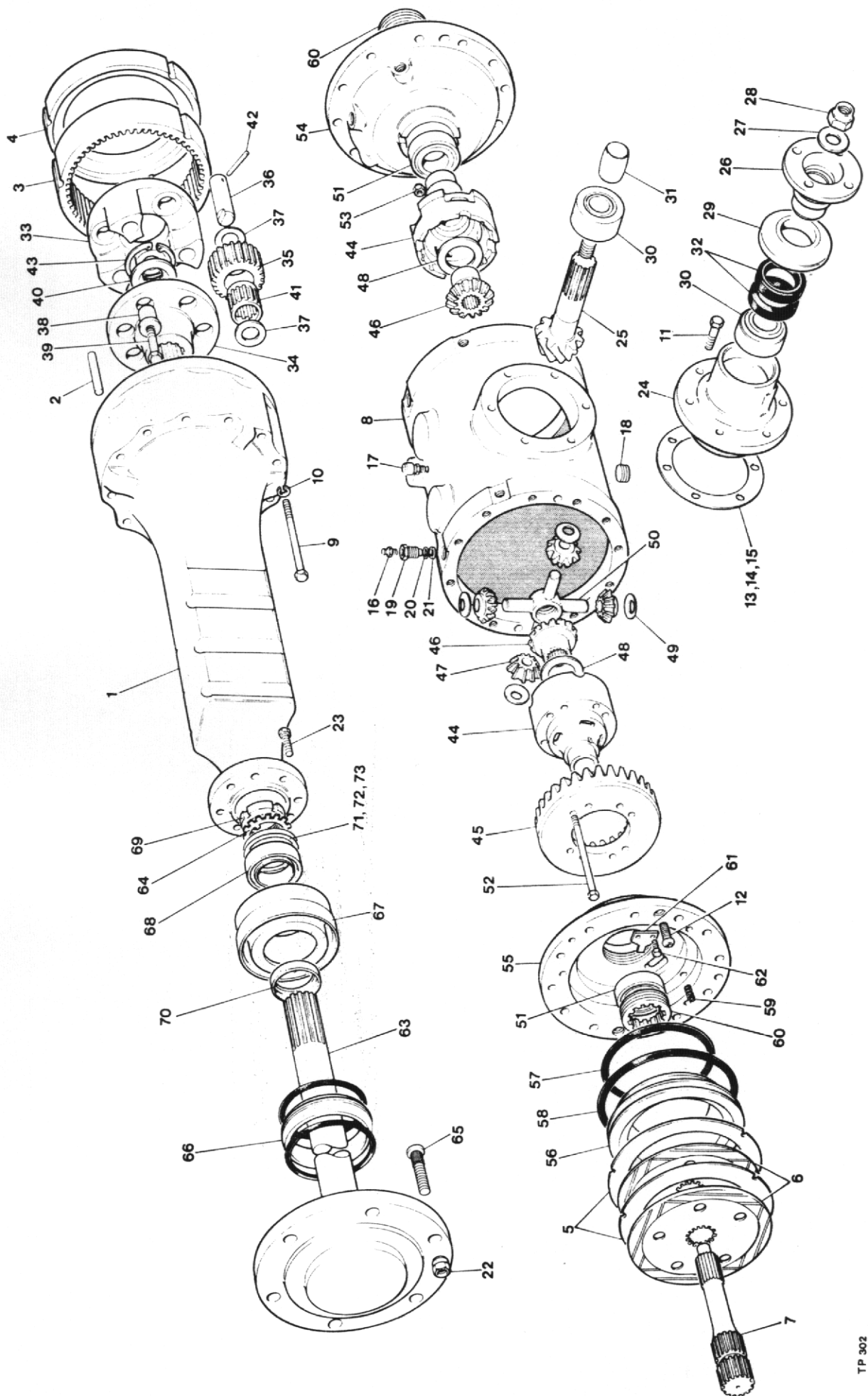

DRIVE AXLE (Cont'd.)

Item No.	Part No.	Description	Qty.
57	002-0100	Piston Oil Seal	2
58	002-0110	Piston Oil Seal	2
59	011-0010	Compression Spring	6
60	250-2150	Bearing Adjusting Nut	2
61	400-2160	Lock Plate - Bearing Adjusting Nut	2
62	012-0010	Screw - Lock Plate	4
63	250-9790	Axle Shaft and wheel flange assembly	2
64	250-0980	Clamp Washer	2
65	250-0450	Wheel Stud	12
66	002-0130	Shaft Oil Seal	2
67	250-0140	Oil Seal Housing	2
68	001-0090	Shaft Bearing	2
69	250-0800	Locking Collar	2
70	250-1610	Axle Shaft Distance Piece	2
71	250-1240	Bearing Dist. Shim (0.25)	A/R
72	250-1630	Bearing Dist. Shim (0.30)	A/R
73	250-1640	Bearing Dist. Shim (0.38)	A/R
257		Drive Axle Complete (2 per m/c)	

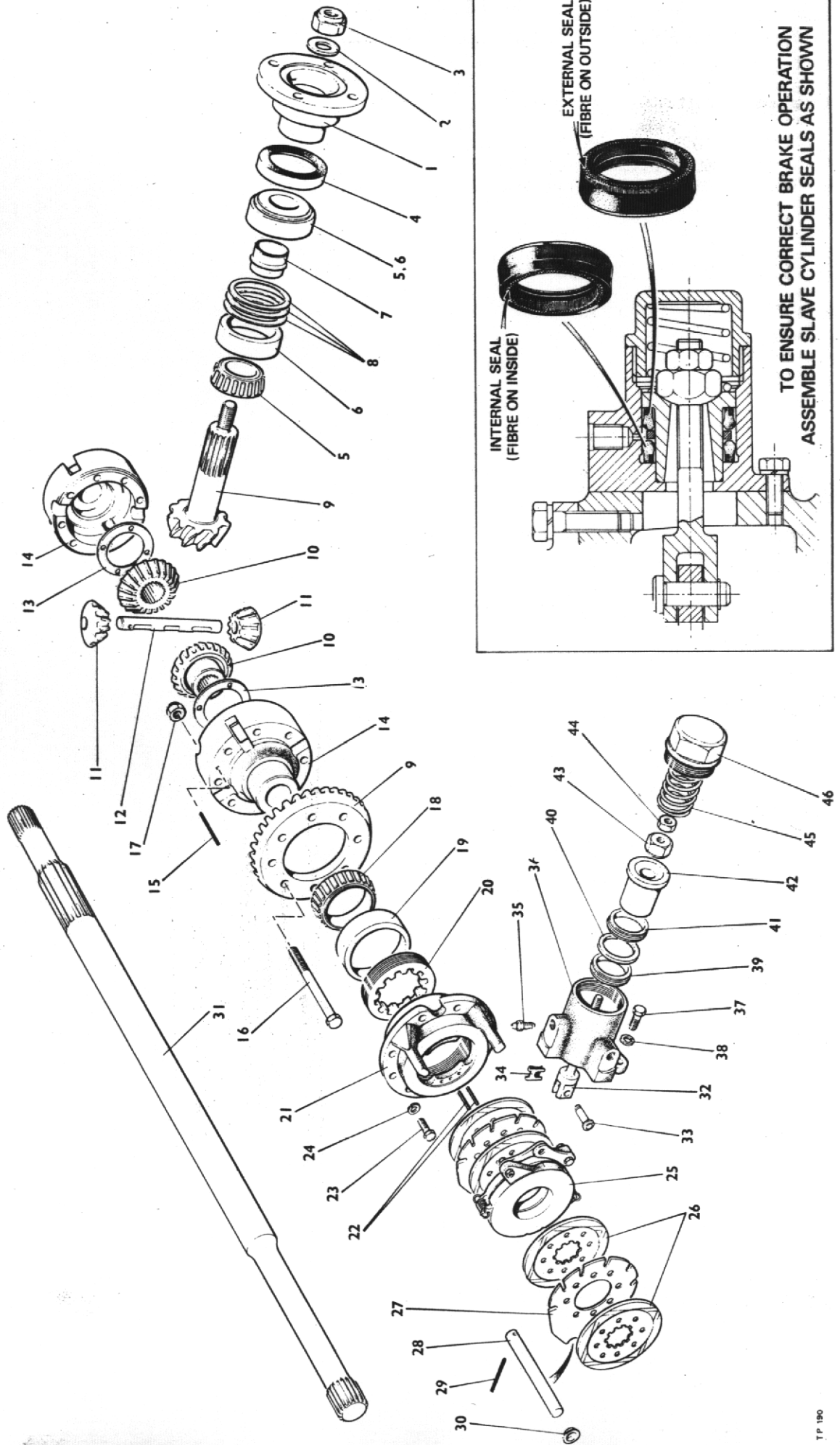

DRIVE AXLE
(HAMWORTHY 1000 SERIES)

DIFFERENTIAL, HALF-SHAFTS & BRAKE ASSEMBLY

Item No.	Part No.	Description	Qty.
1	630130330	Coupling flange	1
2	630189112	Coupling flange washer	1
3	748415103	Coupling flange nut	1
4	742736074	Coupling flange oil seal	1
5	660101110	Bevel pinion bearing cone	2
6	660101128	Bevel pinion bearing cup	2
7	630075741	Bevel pinion bearing cone spacer	1
8	630041503	Bevel pinion bearing shim .05mm (.002")	A.R.
	630041511	Bevel pinion bearing shim .13mm (.005")	A.R.
	630041529	Bevel pinion bearing shim .25mm (.010")	A.R.
9	630127732	Bevel pinion	1
	630128730	Bevel wheel	1
10	630124101	Differential bevel wheel	2
11	630125058	Differential pinion	2
12	630126114	Differential trunnion	1
13	630031173	Differential bevel wheel thrust washer	2
14	630123350	Differential cage (recessed)	1
	630123368	Differential cage (bossed)	1
15	660170206	Roll pin	1
16	748230825	Differential cage bolt	8
17	748415061	Differential cage bolt nut	8
18	660100237	Differential bearing cone	2
19	660100245	Differential bearing cup	2
20	630033351	Differential bearing nut	2
21	630143184	Differential bearing housing	2
22	660390010	Roll pin	4
23	748211015	Differential bearing housing setscrews	16
24	660240116	Differential bearing housing setscrew spring washer	16
25	660020765	Actuator	2
26	660021177	Middle plate) Supplied as an Assembly - 680600406	8
27	660020773	Intermediate plate)	4
28	630096358	Torque pin	2
29	660170214	Retaining pin	2
30	630036636	Torque pin cover	2
31	630045728	Drive shaft	2
32	630066138	Brake pull rod	2
33	630096291	Brake link pin	2
34	660060258	Brake link pin circlip	2
35	660500055	Brake cylinder bleed valve	2
36	630062244	Brake cylinder	2
37	748210777	Brake cylinder setscrew	4
38	660240108	Brake cylinder setscrew spring washer	4
39	660300167	Brake piston seal (Internal)	2
40	630075774	Spacer	2
41	660300159	Brake piston seal (External)	2
42	630064190	Brake piston	2
43	630183255	Brake pull rod nut	2
44	748440077	Brake pull rod locknut	2
45	630069066	Brake piston spring	2
46	630036552	Brake cylinder cap	2
47	693300846	Drive Axle complete (not illustrated)	2

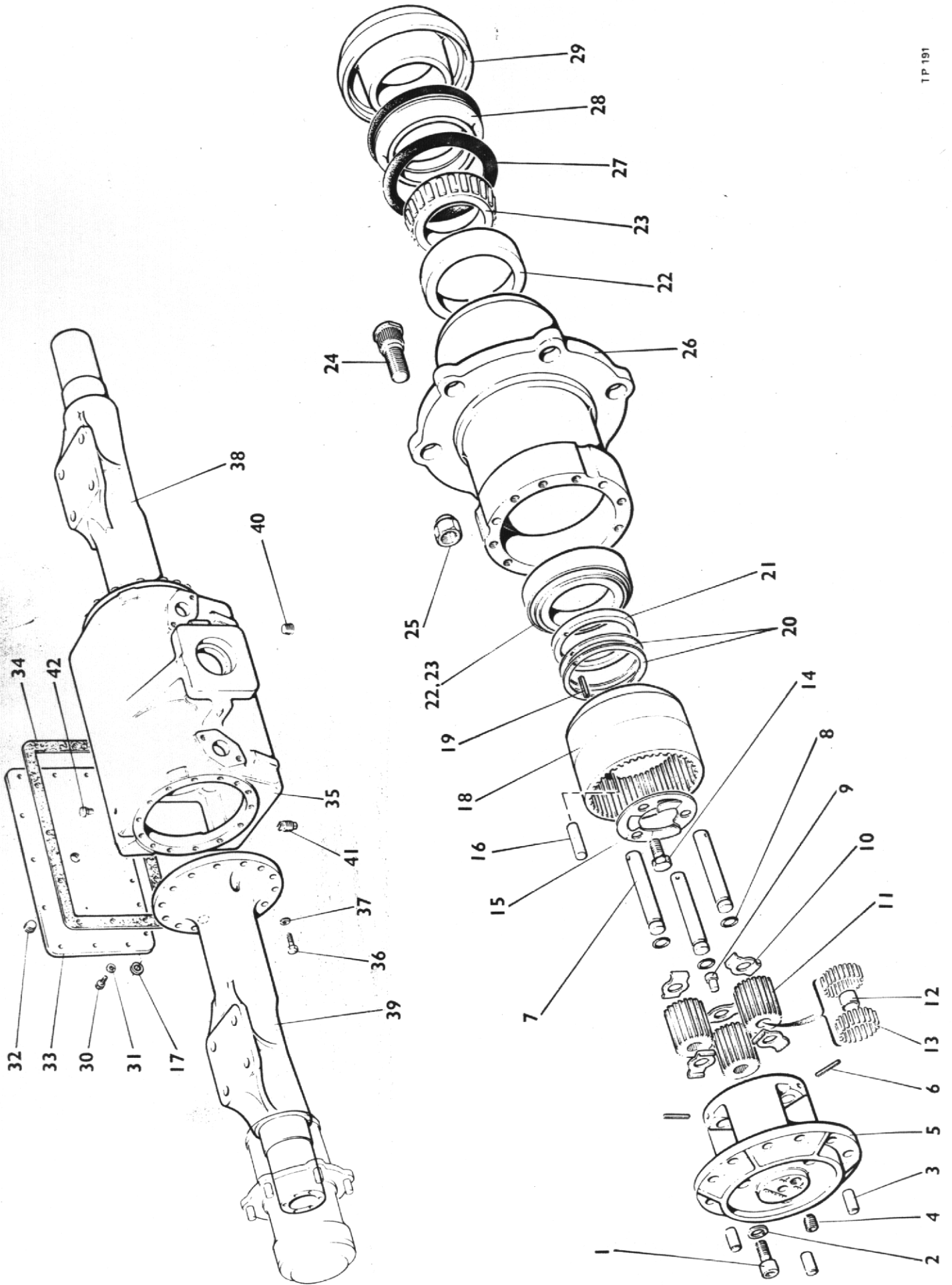

DRIVE AXLE
(HAMWORTHY 1000 SERIES)

CASING & HUB ASSEMBLY

Item No.	Part No.	Description	Qty.
1	748011068	Planet Carrier Capscrew	18
2	740773053	Planet Carrier Capscrew Spring Washer	18
3	740100679	Planet Carrier Dowel	6
4	742223016	Planet Carrier Plug (1/8" B.S.P.T.)	2
5	630029565	Planet Carrier	2
6	660390010	Planet Pin Retaining Pin	6
7	630030258	Planet Pin <i>✓ 30090A0142</i>	6
8	742010082	Planet Pin "O" Ring	6
9	660420015	Planet Carrier Thrust Button	2
10	630031413	Planet Wheel Side Washer	12
11	630027247	Planet Wheel <i>✓ 30090A0146</i>	6
12	630075873	Planet Wheel Needle Roller Spacer	6
13	660200185	Planet Wheel Needle Rollers	240
14	630180509	Annulus Setscrew	6
15	630023386	Retaining Plate	2
16	630048128	Dowel	6
17	742171033	Washer	7
18	630026439	Annulus	2
19	660170180	Bearing Spacer Pin	2
20	630041701	Shim Pack	A/R
21	630075550	Bearing Spacer	2
22	660101185	Hub Bearing Cup <i>3 30062A0220</i>	2
23	660101193	Hub Bearing Cone	2
24	10099 A01	Wheel Stud	12
25	630021075	Wheel Nut	12
26	630017719	Hub	2
27	660310174	"O" Ring (Spares Only)	4
28	660300233	Hub Oil Seal	2
29	630016430	Distance Piece	2
30	748210751	Casing Cover Setscrew	16
31	660240108	Casing Cover Setscrew Springwasher	9
32	742222034	Filler/Lever Plug (As Item 40)	1
33	630036479	Axle Casing Rear Cover	1
34	630037378	Rear Cover Gasket	1
35	630001580	Axle Centre Casing	1
36	748230700	Mounting Arm Bolt	28
37	660240116	Mounting Arm Bolt Spring Washer	28
38	630006381	Mounting Arm - Left Hand	1
39	630006373	Mounting Arm - Right Hand <i>630006371</i>	1
40	742222034	Plug - 1/2" B.S.P.T. (As Item 32)	1
41	660190097	Plug - Magnetic Drain	1
42	660500014	Breather	1
	680300478	Hub Assembly (comprising items 22, 24, 25 & 26)	
	680500143	Planet Carrier Assembly (comprising items 5-13 inclusive)	
	693300846	Drive Axle Complete (not illustrated)	2

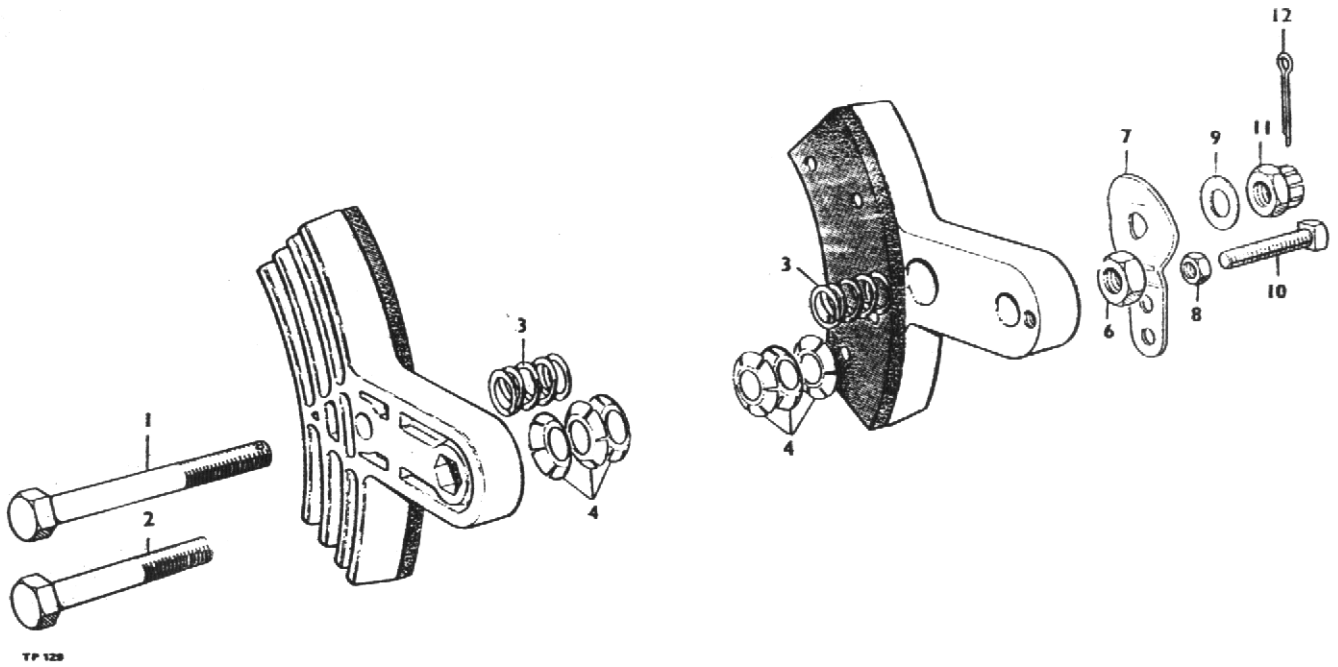

CALIPER, parking brake

Item	Part no	Description	Qty
1A	10578A01	CALIPER, one pair, assembly	1
1	28S02T	SCREW	1
2	28S02P	SCREW	1
3	10578A0101	SPRING, centring	2
4	10578A0102	WASHER, tension	6
6	9S02	NUT	1
7	10578A0104	CAM	1
8	230S01	NUT, locking	1
9	10578A0105	WASHER	1
10	66S01H	SCREW, set	1
11	227S02	NUT, castle	1
12	44S01C	PIN, cotter	1
13	1072A4	PAD c/w rivets	2

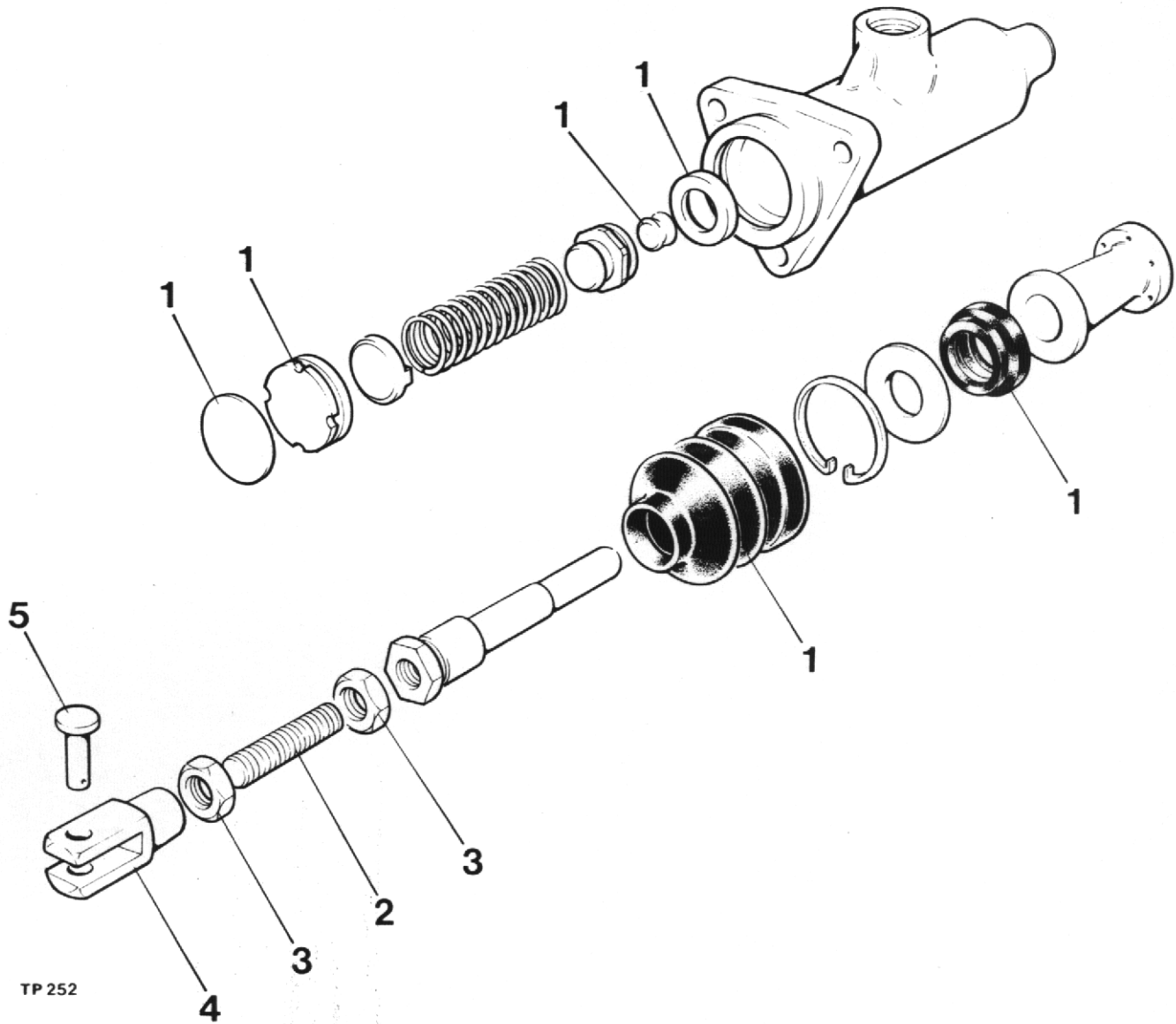

BRAKE MASTER CYLINDER
(for m/c's fitted with Newage Axles)

Item No.	Part No.	Description	Qty.
	22128-3	Master cylinder Assembly (less items 2 to 5 inc.)	2
1	SSB 793	Seal Kit	A/R
2	ESE 189	Threaded Rod	1
3		Nut 7/16" UNF	2
4	4-60-339	Clevis	1
5	FSE 375	Clevis Pin	1

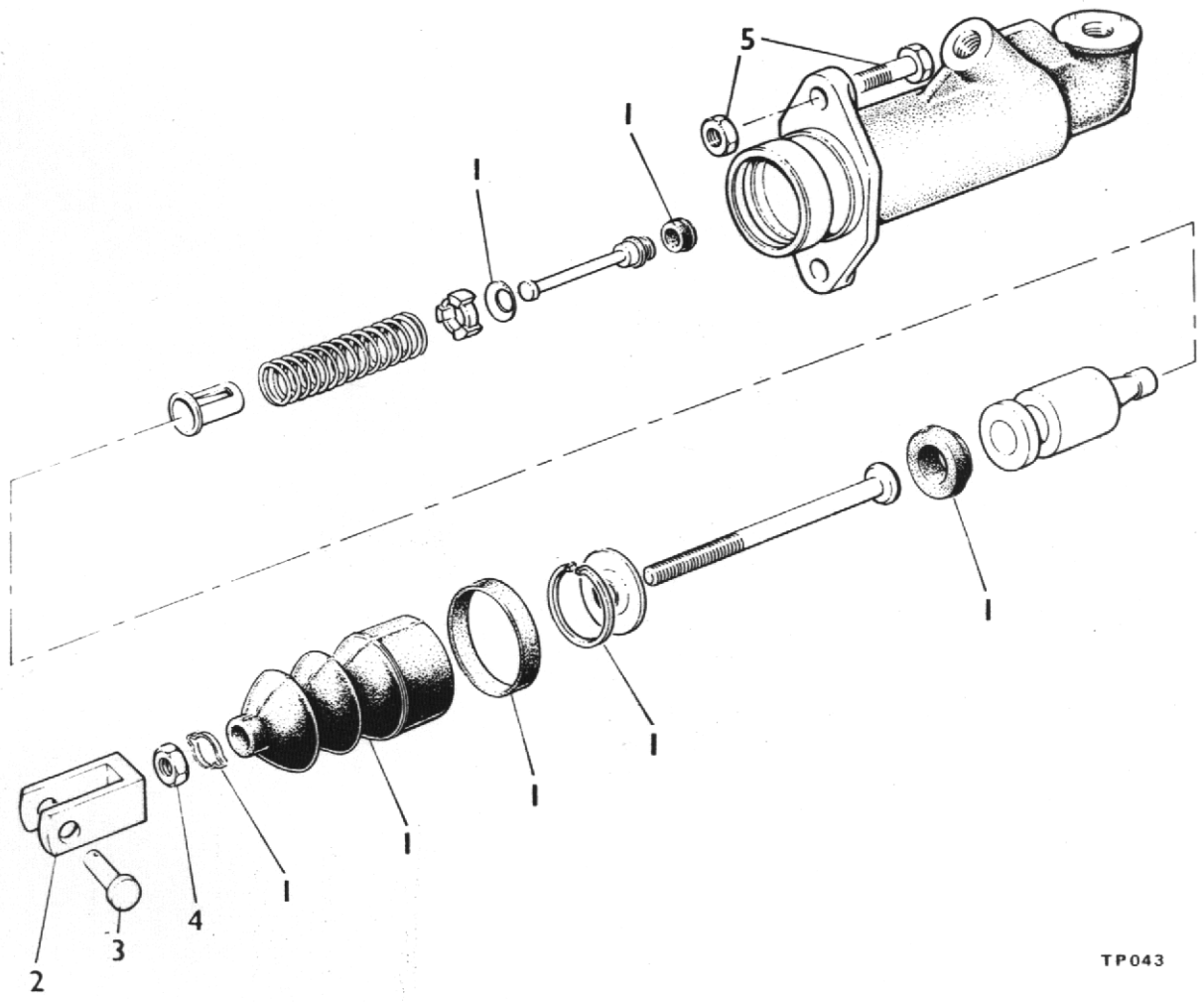

TP043

BRAKE MASTER CYLINDER ASSEMBLY
 (for m/c's fitted with Hamworthy Axles)

Item No.	Part No.	Description	Qty.
	64066004	Master Cylinder Complete	2
1	SP.2636	Service Kit	A/R
2	64671286	Clevis	1
3	C174Y	Clevis Pin	1
4	64100052	Locknut	1
5		Bolt M10 x 40mm long & locknut	2

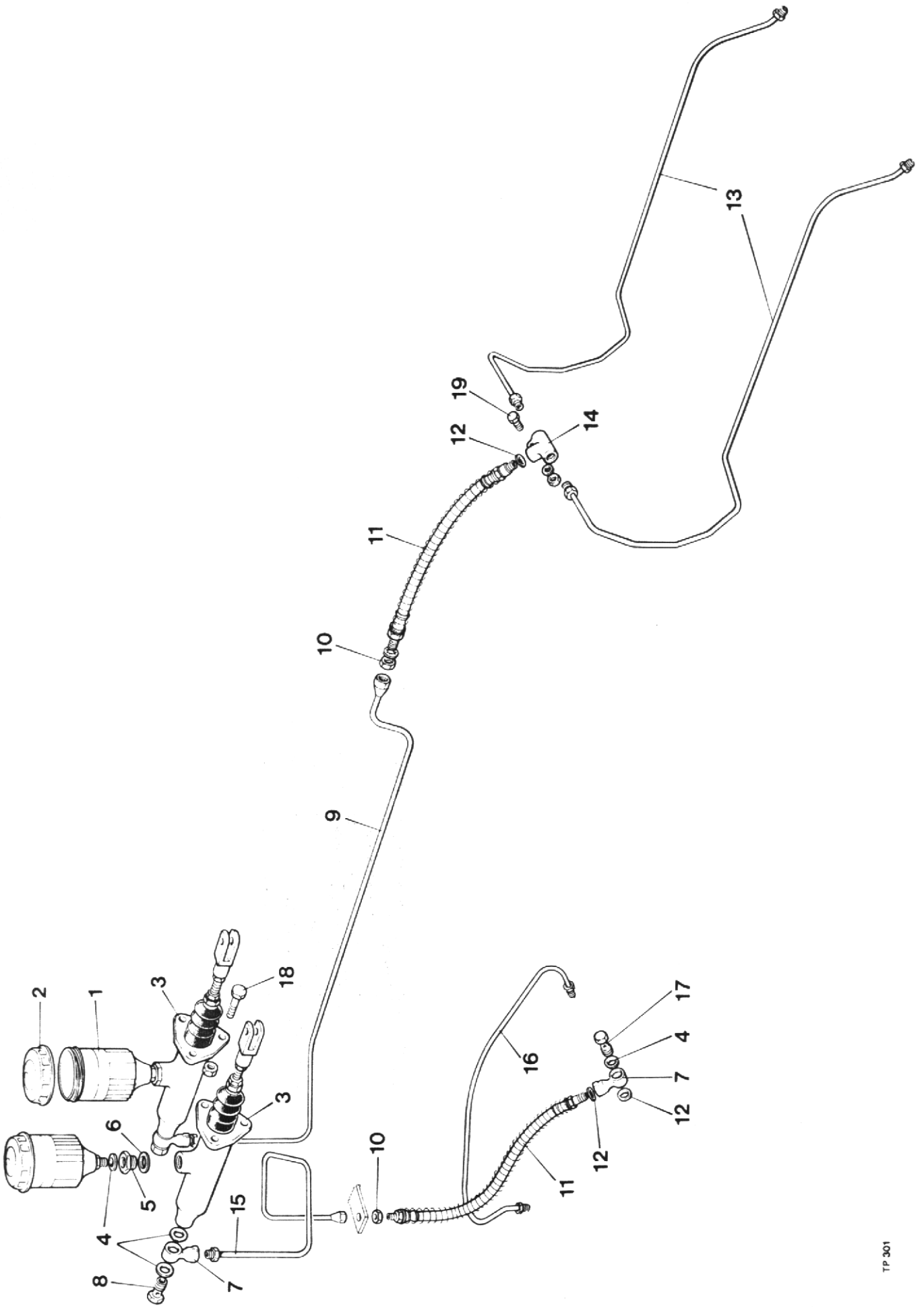

BRAKE PIPES & FITTINGS
(for m/c's fitted with Newage Axles)

Item No.	Part No.	Description	Qty.
1	64046158	Header Tank c/w Cap.	2
2	64474602	Cap	2
3	22128-3	Master Cylinder (See Master Cyl. Page)	2
4	378700	Washer	7
5	ESE 187	Adaptor	2
6	KL 44532	Washer	2
7	64474287	Banjo	3
8	64473063	Banjo Bolt	2
9	DM79-3	Pipe 3/16" dia. x 38" long	1
10	64100050	Thin Nut	2
11	64047903	Flex. Pipe 11" long	2
12	378703	Washer	3
13	DM78-13	Pipe 3/16" dia. x 39½" long	2
14	64474341	Tee	1
15	DM 79-2	Pipe 3/16" dia. x 19" long	1
16	DM78-16	Pipe 3/16" dia. x 13½" long	1
17	376102W	Banjo Bolt	1
18		Bolt M8 x 30mm long & Nut	6
19		Bolt M6 x 40mm long & Nut	1

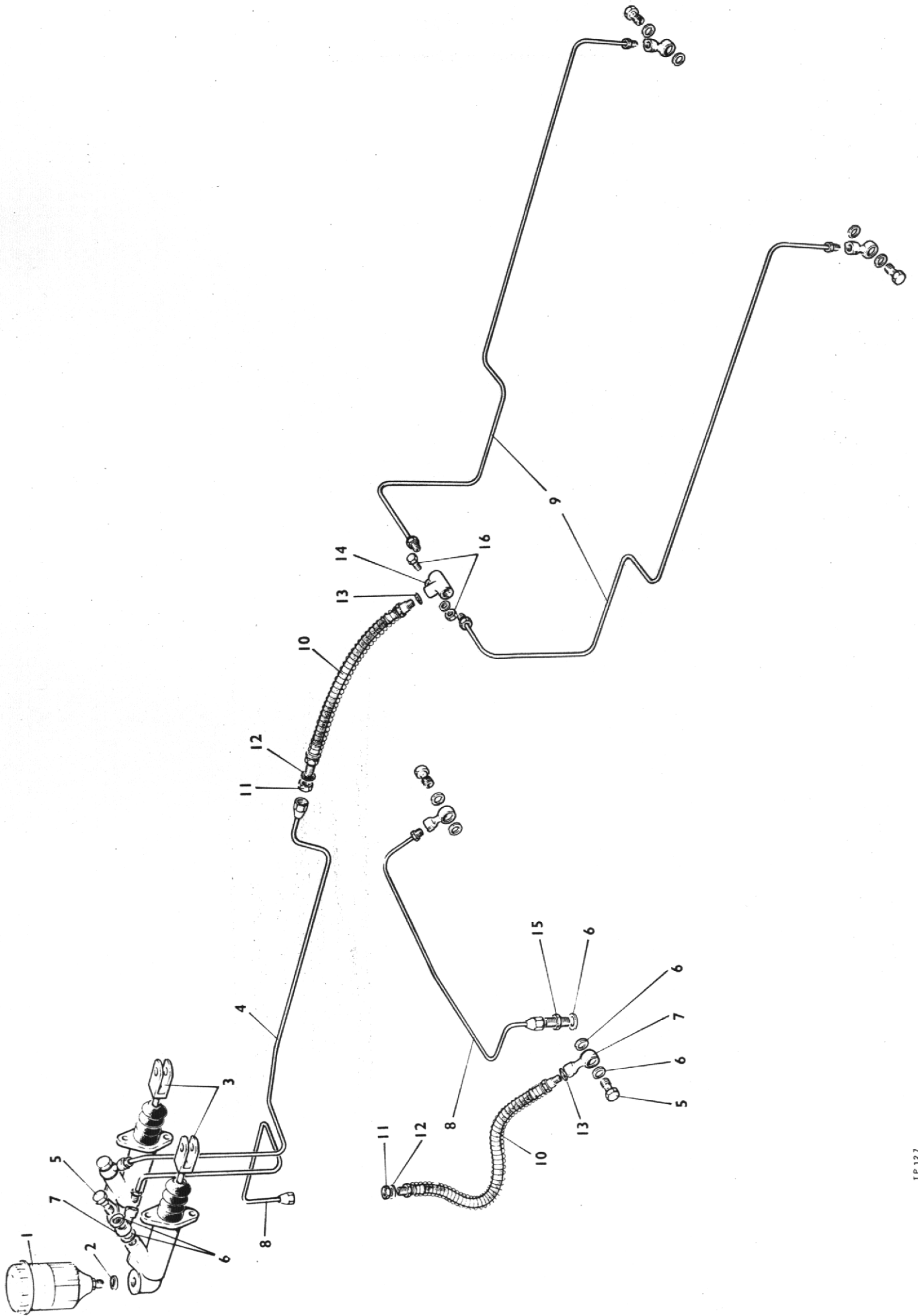

BRAKE PIPES AND FITTINGS.

(for m/c's fitted with Hamworthy Axles)

Item No.	Part No.	Description	Qty.
1	64046158	Header tank	2
2	4-35-378	Thick copper washer	2
3	64066004	Master cylinder (See page 37)	2
4	DM-79-3	Pipe 3/16" dia x 38" long (master cyl. to front flex)	1
5	64473063	Banjo bolt	6
6	678700	Washer	13
7	64474287	Banjo	6
8	DM-79-2	Pipe 3/16" dia. x 19" long (master cyl. to rear flex & rear slave cyl. link)	2
9	DM-78-13	Pipe 3/16" dia x 39½" long (tee to front axle)	2
10	64047903	Flex Pipe 11½" long	2
11	64100050	Locknut	2
12		Shakeproof washer 3/8" dia	2
13	378703	Washer	2
14	64474341	Tee	1
15	64473623	Adaptor 3/8" UNF x 7/16" UNF	1
16		Bolt M6 x 25mm long & locknut	1

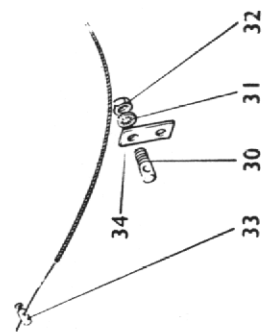
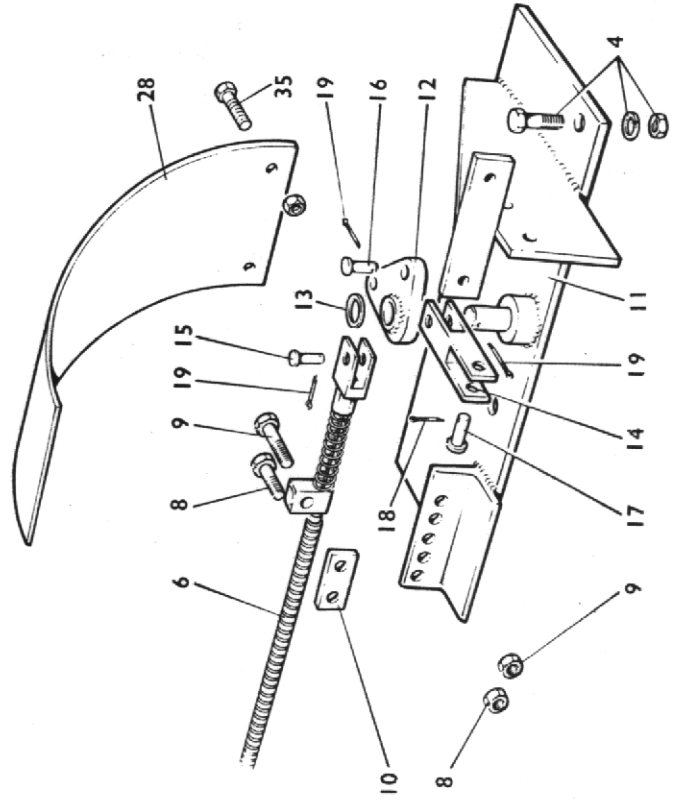
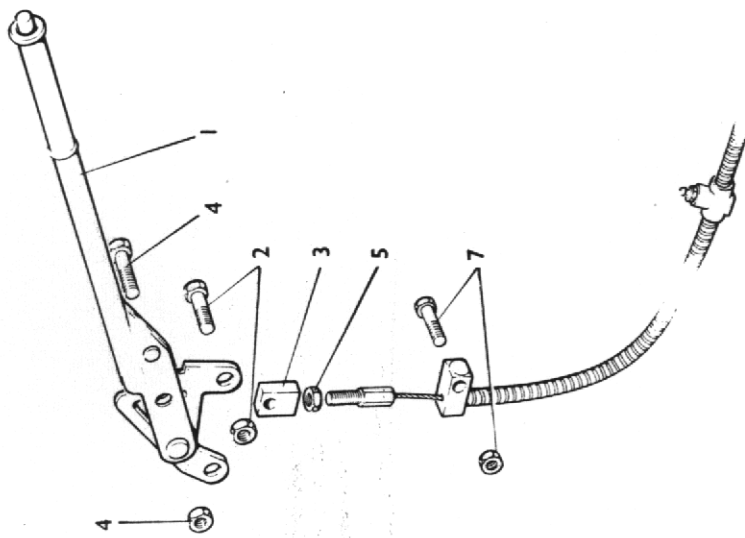
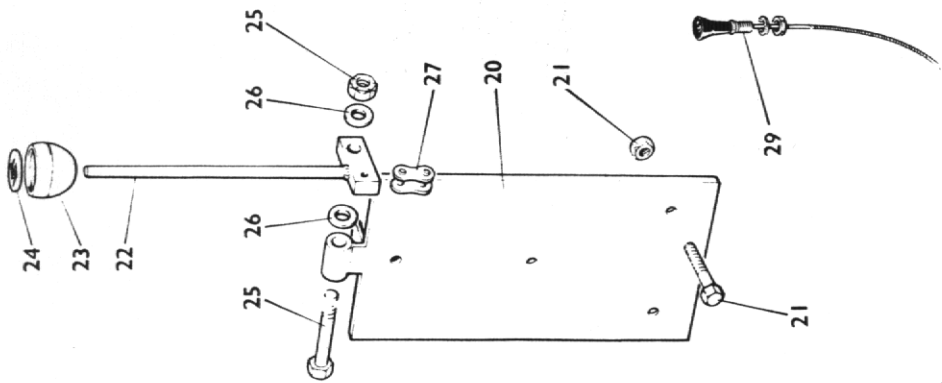

**HANDBRAKE VALVE CONTROL LEVER &
ENGINE STOP CONTROL**

Item No.	Part No.	Description	Qty
1	303	Handbrake lever	1
2		Bolt M10 x 25mm long & locknut	2
3	L309	Block	1
4		Bolt M10 x 40mm long & locknut	4
5		Nut 3/8" BSF	1
6	4-35-111	Handbrake cable	1
7		Bolt M8 x 35mm long & locknut	1
8		Bolt M8 x 25mm long & locknut	1
9		Bolt M8 x 45mm long & locknut	1
10	4-35-349	Disc Brake adjusting Plate	1
11	CSE 166	Transmission Brake Mounting Bracket	1
12	4-35-256	Bell crank	1
13		Flat washer 1/2" dia	1
14	4-35-253	Double clevis	1
15	C174X	Clevis Pin	1
16	C174Y	Clevis Pin	1
17	4-35-264	Clevis Pin	1
18		Split Pin 1/16" dia	1
19		Split Pin 3/32" dia	3
20	F4-45-173	Hydraulic Valve Mounting Bracket	1
21		Bolt M10 x 30mm long & locknut	2
22	F4-45-185	Hydraulic Valve Lever	1
23	F4-45-184	Knob	1
24	DM156	Label	1
25		Bolt 3/8" BSF x 2 1/4" long & 2 locknuts	1
26		Flat washer 3/8" dia	2
27	4-60-178	Connecting Link	1
28	CSE 165	Handbrake Disc Guard	1
29	4-60-239	Engine stop control cable assembly	1
30	4-60-242	Clamp Screw	1
31		Springwasher 3/8" dia	1
32		Nut 3/8" UNF	1
33	4-35-196	Solderless nipple	1
34	CSE 145	Stop Control cable bracket	1
35		Bolt M6 x 20mm long & locknut	2

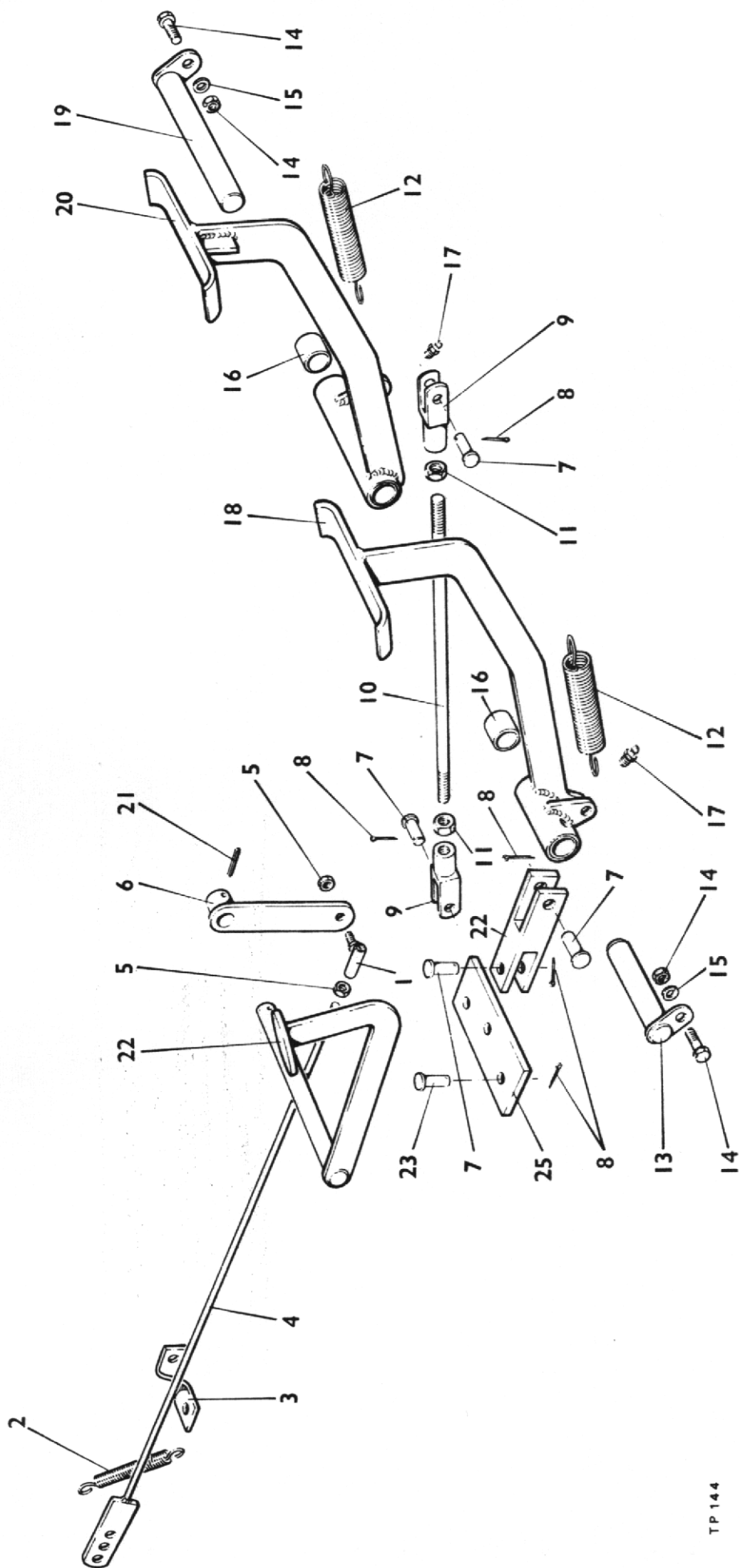

PEDALS AND CONTROLS

Item No.	Part No.	Description	Qty.
1	C160B	Accelerator Rod Ball End	1
2	C173D	Spring	1
3	C163	Spring Attachment Bracket	1
4	CSE 188	Accelerator Rod	1
5		Nut 1/4" BSF	2
6	C129	Accelerator Lever	1
7	C174X	Pin	4
8		Split Pin 3/32" x 1"	6
9	C174A	Clevis	2
10	T21A	Clutch Rod 3/8" BSF x 12 1/2" long	1
11		Nut 3/8" BSF	2
12	C173B	Spring	2
13	CSE 114	Brake Pedal Pivot Pin	1
14		Bolts M8 x 25mm long & Nuts (Pedal pins)	2
15		Plain Washer M8	2
16	WB1010	Bush	4
17	T-ST	Grease Nipple	2
18	CSE 120	Footbrake Pedal	1
19	CSE 113	Clutch Pedal Pivot Pin	1
20	CSE 108	Clutch Pedal	1
21	C129A	Tension Pin	1
22	CSE 148	Brake Compensator Clevis	1
23	C174Y	Clevis Pin	2
24	CSE 111	Accelerator Pedal	1
25	CSE 147	Brake Compensator	1

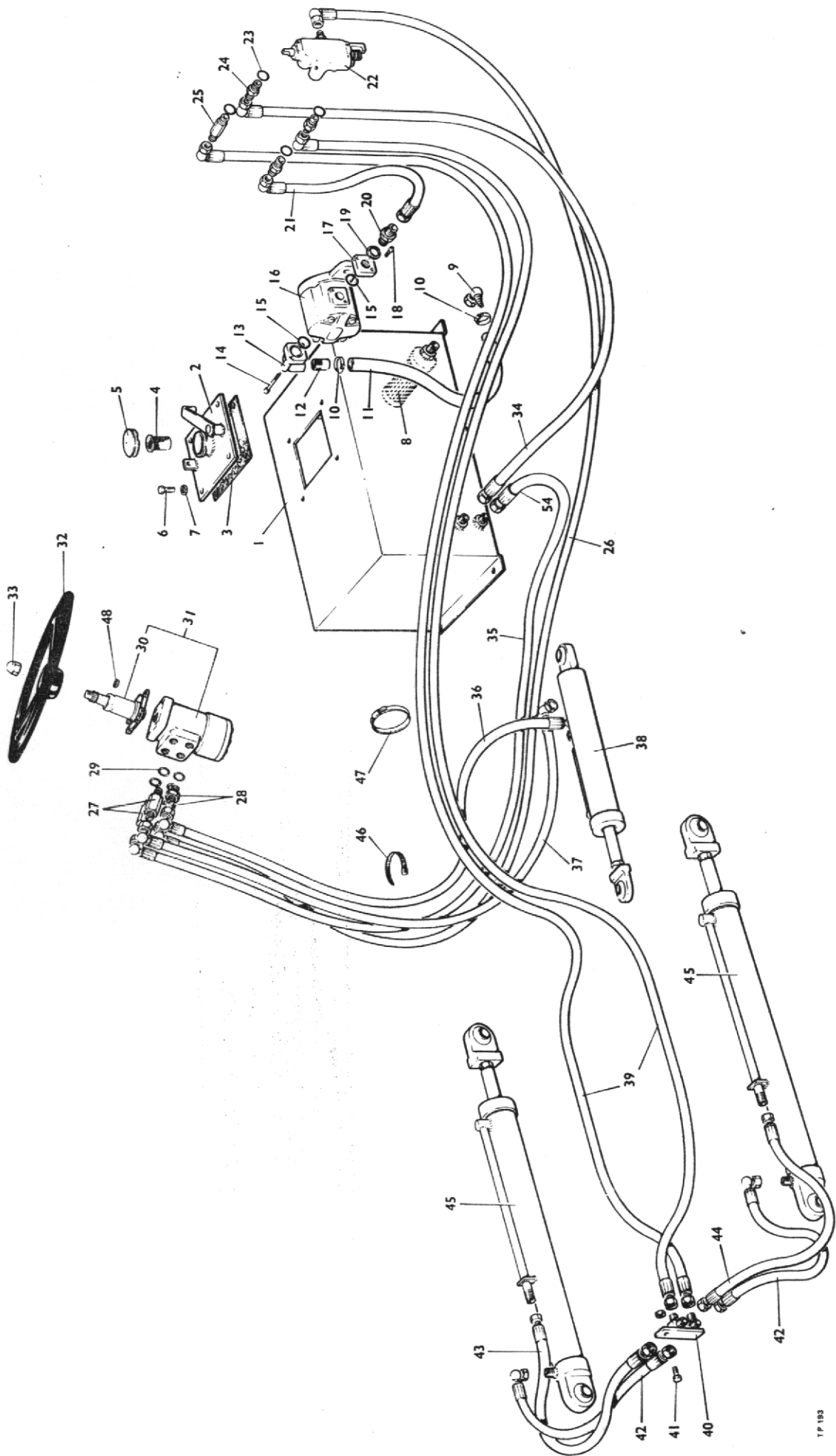

HYDRAULIC PIPES AND FITTINGS

Item No.	Part No.	Description	Qty.
1	CSE 123	Hydraulic Tank	1
2	4-35-187	Cover Plate Assembly	1
3	T18B	Gasket	1
4	P1145	Strainer	1
5	P2578-2	Cap	1
6		Bolt 5/16" UNF x 3/4" long	4
7		Shakeproof Washer 5/16" dia	4
8	UC1457	Filter	1
9	BSE 109	90° Hose Fittings 3/4" BSP	1
10	T63M	Hose Clip	2
11	4-60-160	Hose 3/4" Cotton Braid x 30"	1
12	T48	Pump Inlet Adaptor	1
13	1PE4	Pump Elbow	1
14		Cap Screw 5/16" UNC x 2 1/4" long	2
15	DH69A5	'O' Ring	2
16	IP3072-CPSFB	Pump (see relavent Page)	1
17	4-35-261	Adaptor	1
18		Cap Screw 5/16" UNC x 1" long	2
19	T14I	Seal 3/8" BSP	1
20	T14J	Adaptor 3/8" BSP x 3/8" BSP	1
21	F4-45-176	Hose 3/8" x 410mm ST-90°	1
22	305-011-AAB	Hydraulic Control Valve (See Relavent Page)	1
23	S.9698	'O' Ring	4
24	CSE 186	Adaptor 3/8" BSP x 7/8" UNF (Short)	3
25	4-60-158	Adaptor 3/8" BSP x 7/8" J.I.C. (Long)	1
26	4 SHL 86	Hose 3/8" x 98" 90° - 90°	1
27	4-60-115	Adaptor 3/8" BSP x 3/4" UNF (Long)	2
28	4-35-40K	Adaptor 3/8" BSP x 3/4" UNF (Short)	2
29	2ST 72J	'O' Ring	4
30	099-530063	Steering Column	1
31	CSE 178	Steering Valve Complete	1
32	347K	Steering Wheel	1
33	C318	Domed Nut 5/8" UNF	1
34	4-60-133	Hose 3/8" x 48" ST - 90°	1
35	4-35-246	Hose 3/8" x 67" ST - 90°	1
36	CSE 138	Hose 3/8" x 62" 90° - 90°	1
37	CSE 137	Hose 3/8" x 68" 90° - 90°	1
38	TD 3894	Hydraulic Ram	1
39	F4-45-177	Hose 3/8" x 3050mm ST-90°	2
40	4-35-388	Tee Assembly (FWD Tip & High Discharge)	1
	5ST93	Tee Assembly (Turntable) (not illustrated)	1
41		Bolt M6 x 25mm long & nut (FWD Tip & High Discharge)	1
		Bolt M6 x 65mm long & nut (Turntable) (not illustrated)	1
42	4-35-365	Hose 3/8" BSP x 20" long ST - 90° (FWD Tip & High Disch.)	2
	5ST 87	Hose 3/8" x 27" 90° - 90° (Turntable) (not illustrated)	2
43	4-35-40E	Hose 3/8" x 25" ST - ST, (FWD Tip & High Discharge)	1
	5ST 85	Hose 3/8" x 27" 90° - 90° (Turntable) (not illustrated)	1
44	4-35-40E	Hose 3/8" x 25" ST - ST (FWD Tip & High Discharge)	1
	5ST86	Hose 3/8" x 27" 90° - 90° (Turntable) (not illustrated)	1
45	4-35-295	Hydraulic ram (FWD Tip & Turntable) (See Relavent Page)	2
	BE-3	Hydraulic ram (High Discharge) (See Relavent Page)	2
46	177	Cable Tie	1
47		Jubilee Clip 32/48mm	1
48	CSE 182	Spacer	2

IT IS RECOMMENDED THAT DANFOSS OSPB STEERING UNITS ARE ONLY SERVICED IN DANFOSS AUTHORISED SERVICE SHOPS.

FOR U.K. - contact - Danfoss (London) Ltd., Perivale Industrial Estate, Horsenden Lane South, Greenford, Middlesex. Tel: 01 998 2041 Telex: 24223.

FOR EUROPEAN COUNTRIES. - contact - Department OG - SHT (Denmark) Telex:50599.

Customers having suitable facilities who wish to service the units themselves are advised to contact Winget Service Department, Winget Ltd., Rochester, Kent, England., who can supply service details.

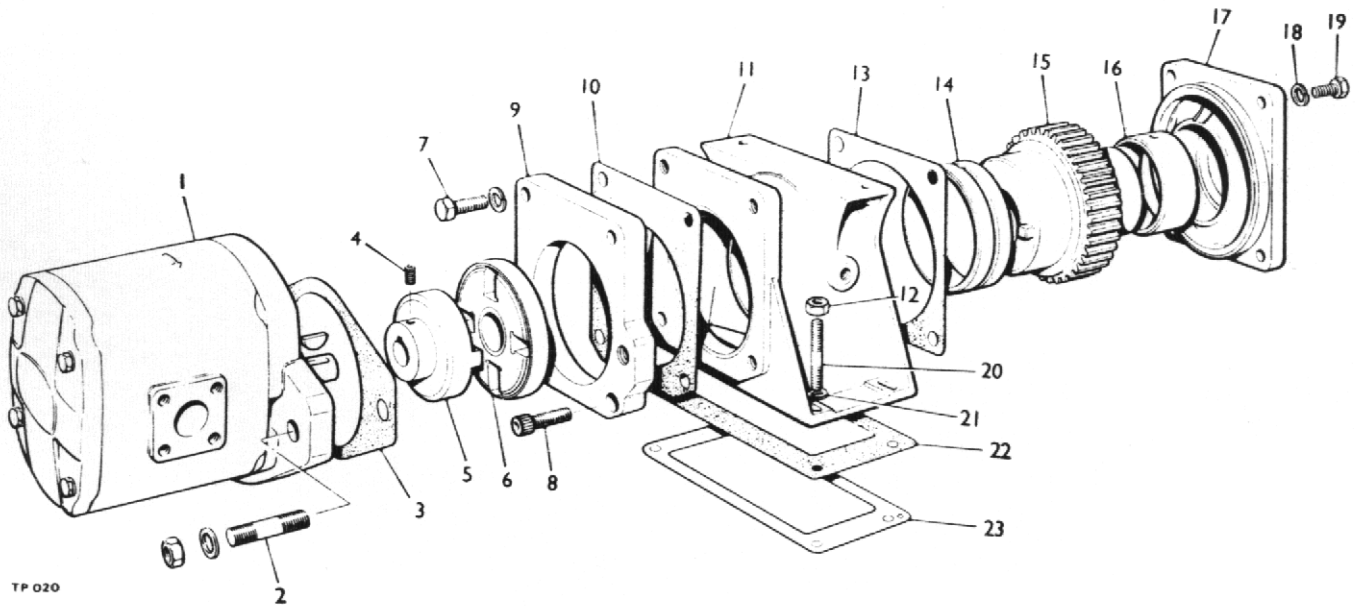

HYDRAULIC PUMP & DRIVE

Item No.	Part No.	Description	Qty.
1	IP3072CPSFB	Pump complete	1
2		Stud, Washer & Nut	2
3	334932	Joint	1
4	724202	Socket Screw 1/4" BSF x 5/16" long	1
5	334967	Coupling (Pump Half)	1
6	266185	Coupling Assy	1
7	725049	Bolt 3/8" BSF x 1" long	2
8	724056	Cap Screw 3/8" BSF x 3/4" long	2
9	292709	Spigot Plate	1
10	266159	Joint	1
11	2-197597	Pump Housing	1
12	726003	Nut 3/8" BSF	4
13	264702	Joint	1
14	2-264704	Bearing	1
15	334968	Gearwheel	1
16	2-202485	Bearing	1
17	264701	Cover - Pump Housing	1
18	786029	Spring Washer - 5/16"	4
19	722024	Bolt 5/16" BSF x 5/8" long	4
20	760061	Stud 3/8" BSF x 1 3/8" long	4
21	786030	Spring Washer - 3/8"	4
22	264700	Joint	1
23	264706	Shim	A/R
24	10190 A01	Seal Kit - (Hydraulic Pump) (Not Illustrated)	A/R

NOTE: Should it be necessary to fit seal kit 10190 A01. Extreme caution must be exercised to ensure that no foreign matter enters the unit.

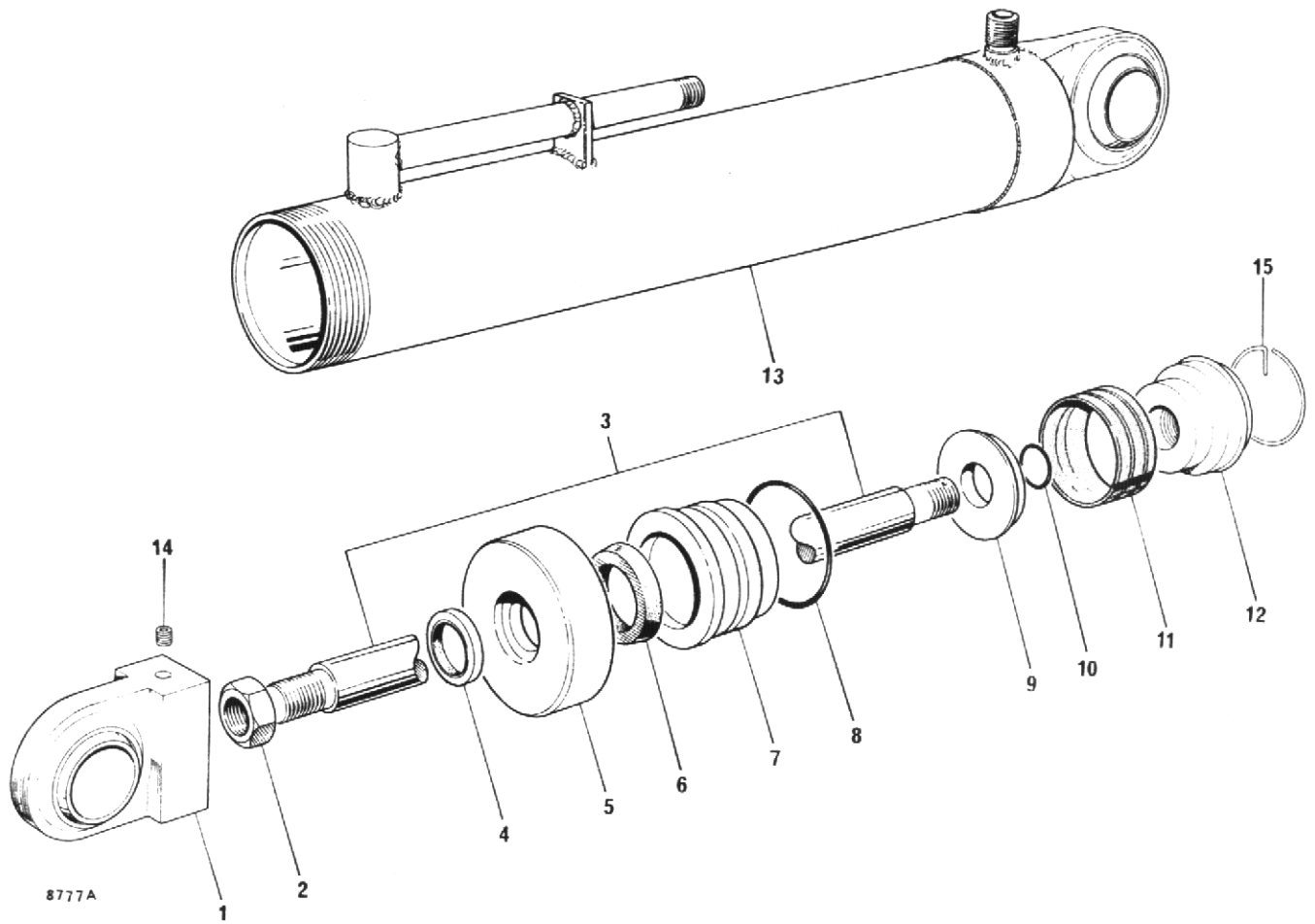

HYDRAULIC RAM (FORWARD TIP & TURNTABLE)

Item No.	Part No.	Description	Qty.
	4-35-295	Ram Complete (2 per M/c except High Discharge M/c's)	
1	K1/11	Piston Rod Fitting	1
2	K1/19	Locknut	1
3	TD3890	Piston Rod	1
4	K1/18	Wiper	1
5	K1/4	Tube Cap	1
6	K1/17	Sleeve Seal	1
7	K1/5	Sleeve	1
8	K1/16	Sleeve 'O' Ring	1
9	K1/15	Backing Washer	1
10	K1/13	Piston 'O' Ring	1
11	K1/12	Piston Seal	1
12	K1/14	Piston Head	1
13	TD 6531	Cylinder, Bosses & End Cap	1
14	K1/21	Grub Screw	1
15	K1/22	Spring Ring	1

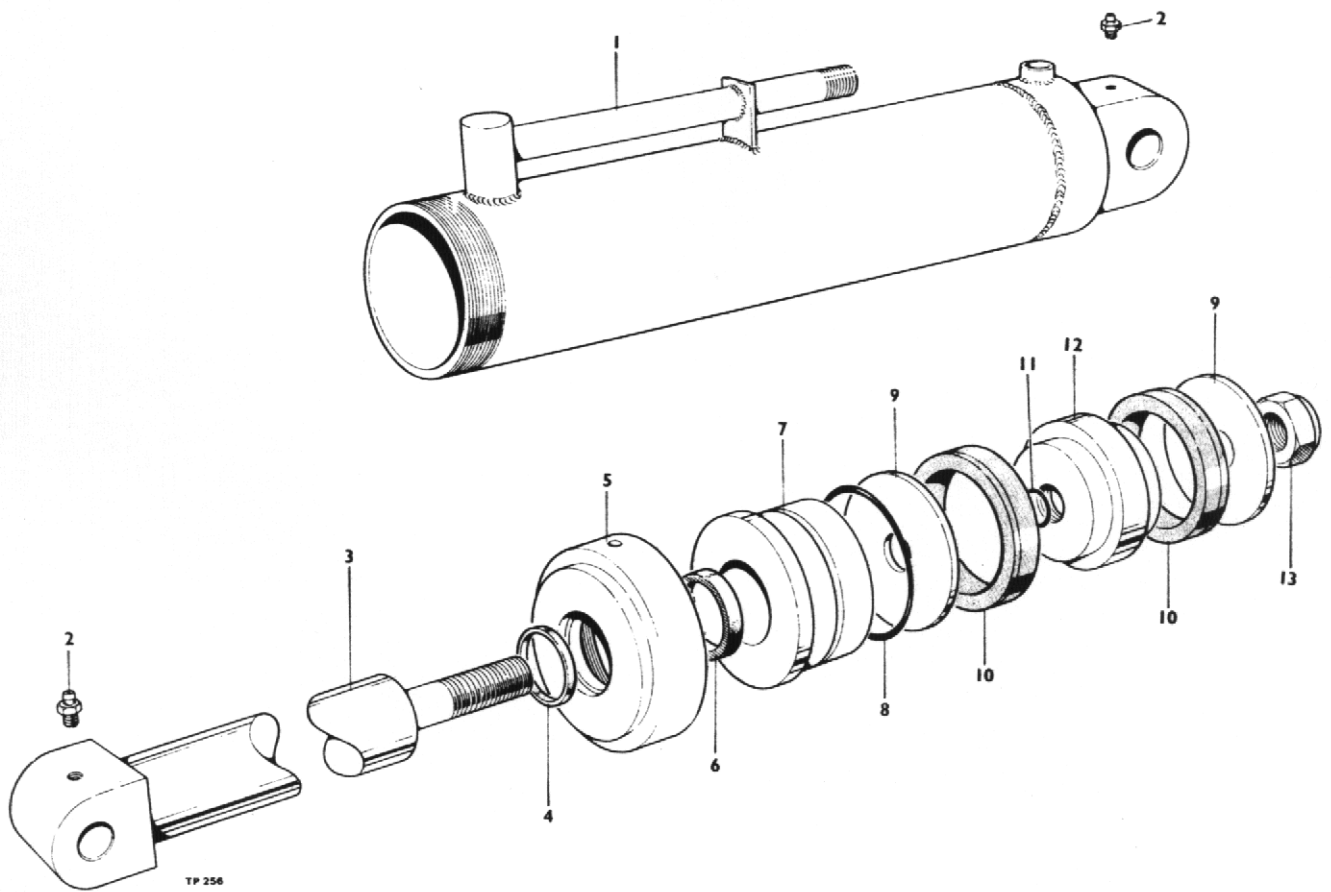

HYDRAULIC RAM (HIGH DISCHARGE)

Item No.	Part No.	Description	Qty.
	BE-3	Ram Assembly Complete (Two per high discharge m/c's only)	
1	BE3-21	Ram Body	1
2	BE3-20	Grease Nipple	2
3	BE3-22	Piston Rod Assembly	1
4	BE3-15	Wiper	1
5	BE3-6	Tube Cap	1
6	BE3-16	Sleeve Seal	1
7	BE3-7	Sleeve	1
8	BE3-13	Sleeve 'O' Ring	1
9	BE3-10	Backing Washer	2
10	BE3-14	Piston Seal	2
11	BE3-12	Piston 'O' Ring	1
12	BE3-9	Piston Head	1
13	BE3-11	Lock Nut	1
	CSE 190	Seal Kit (comprising items 4,6,8,10 & 11)	A/R

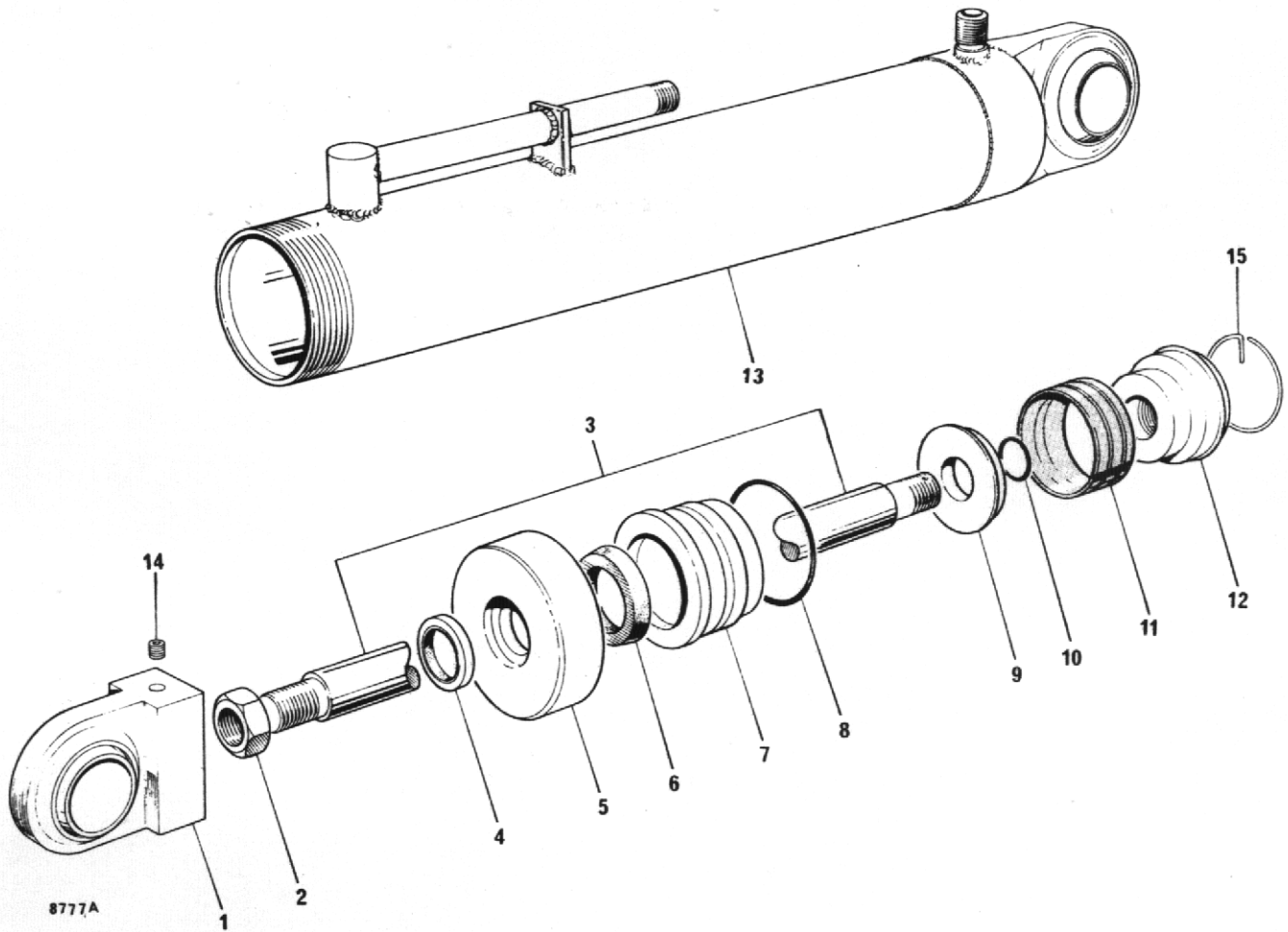

STEERING RAM

Item No.	Part No.	Description	Qty.
	TD3894	Ram Complete (1 Per Machine)	
1	K1/11	Piston Rod Fitting	1
2	K1/19	Locknut	1
3	K1/2	Piston Rod	1
4	K1/18	Wiper	1
5	K1/4	Tube Cap	1
6	K1/17	Sleeve Seal	1
7	K1/5	Sleeve	1
8	K1/16	Sleeve 'O' Ring	1
9	K1/15	Backing Washer	1
10	K1/13	Piston 'O' Ring	1
11	K1/12	Piston Seal	1
12	K1/14	Piston Head	1
13	K1/20	Cylinder, Bosses & End Cap	1
14	K1/21	Grub Screw	1
15	K1/22	Spring Ring	1
	CSE 189	Seal Kit (comprising items 4,6,8,10 & 11)	A/R

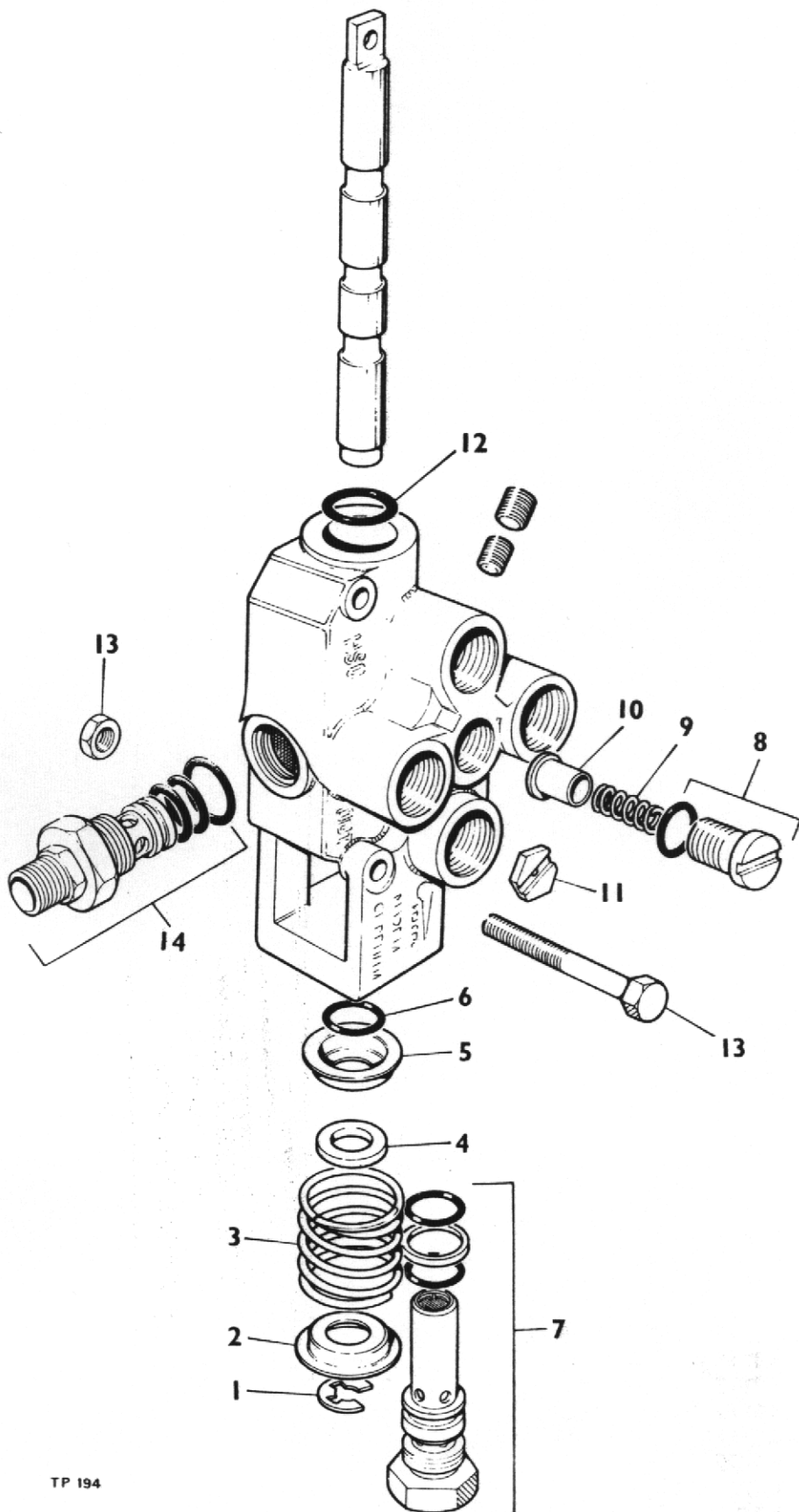

HYDRAULIC CONTROL VALVE

Item No.	Part No.	Description	Qty.
	305-011-AAB	Control Valve Assembly (1 Per M/c)	-
1	16124-50	Clip Ring (1/2" Shaft)	1
2	15546-6	Shallow Washer	1
3	30501-39	Spool Spring	1
4	16048-31	Washer Spacer	1
5	30501-10	Deep Washer	1
6	100-146-012	'O' Ring 3/32" x 5/8" I/D	1
7	300-055-J9A	Relief Valve Assembly	1
8	30501-17	Lift Check Plug Assembly	1
9	30501-13	Lift Check Spring	1
10	30501-12	Lift Check Plunger	1
11	16097-451	Orifice Plate	1
12	100-147-063	'O' Ring	1
13		Bolt 5/16" UNF x 2 1/2" long and Nut	2
14	326-001-SAA	Flow Control valve	1
15	32016-800	Seal Repair Kit (relief valve)	A/R
16	300-024-801	Seal Repair Kit	A/R

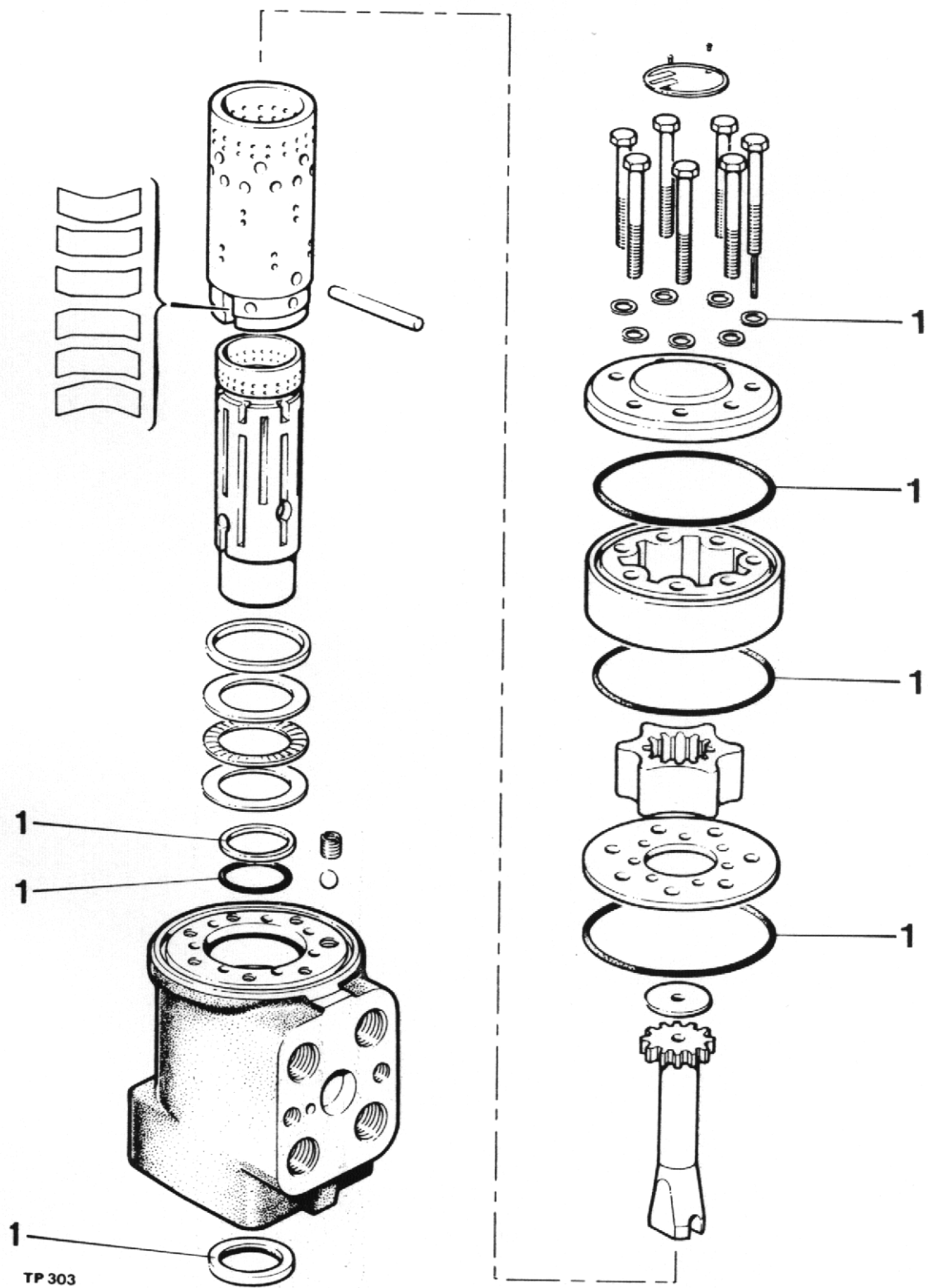

STEERING VALVE (SEALS)

Item No.	Part No.	Description	Qty.
1	10189A01	Seal Kit	A/R

NOTE: Should it be necessary to fit seal kit 10189A01. Extreme caution must be exercised to ensure that no foreign matter enters the unit.

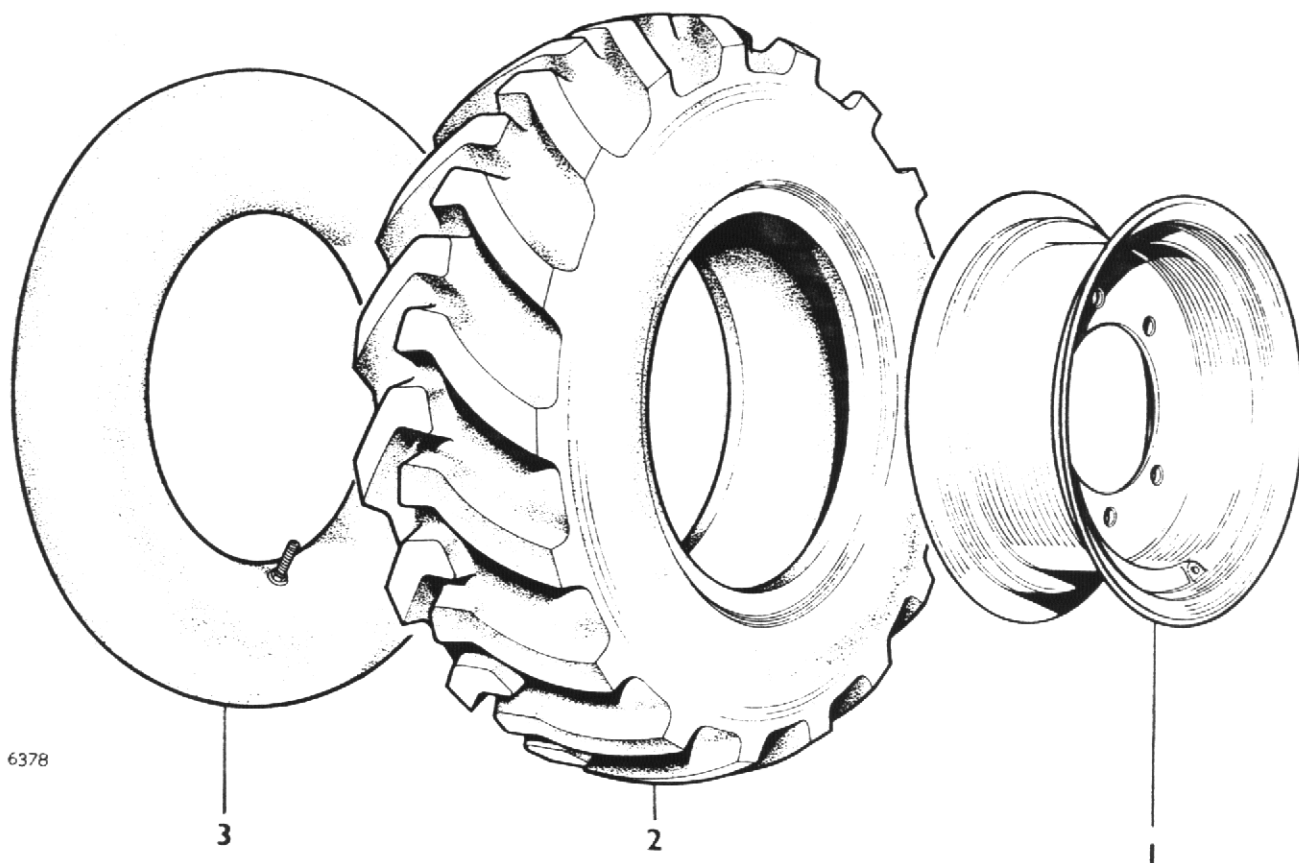

WHEELS AND TYRES

Item No.	Part No.	Description	Qty.
	24S08	R/H Wheel Assembly	2
	24S07	L/H Wheel Assembly	2
1	30183A02	Wheel rim 9 x 18	4
2	20S02	Tyre 10.5 x 18-8 ply	4
3	23S04	Tube 10.05 x 18	4

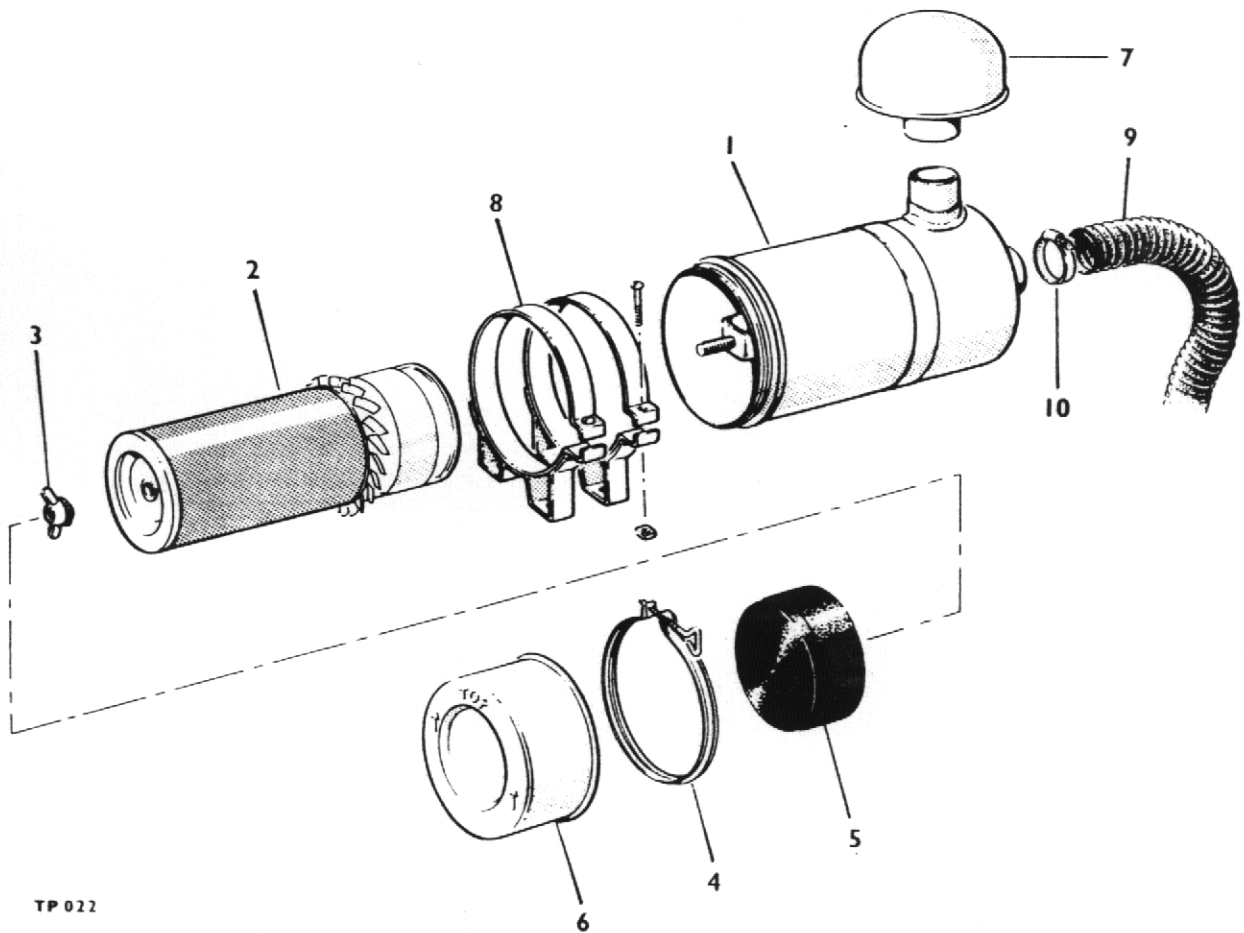

TP 022

AIR CLEANER

Item No.	Part No.	Description	Qty.
1	10532A02	Air Cleaner Assembly	1
2	10532A0101	Element	1
3	V600487	Nut & Gasket Kit	1
4	220229002	Clamp Body	1
5	220229003	Skirt, baffle	1
6	220229004	Cup	1
7	10534A02	Stack Cap	1
8	10533A02	Bracket	2
9	166S02	Hose Flexible 2" Bore x 17" Long	1
10	97S12	Clip Hose	1

DECIMAL, FRACTIONAL AND METRIC EQUIVALENTS

Inches		Milli- metres	Inches		Milli- metres
Fractions	Decimals		Fractions	Decimals	
1/64	0.015625	0.397	33/64	0.515625	13.097
1/32	0.03125	0.794	17/32	0.53125	13.494
3/64	0.046875	1.191	35/64	0.546875	13.891
1/16	0.0625	1.588	9/16	0.5625	14.288
5/64	0.078125	1.984	37/64	0.578125	14.684
3/32	0.09375	2.381	19/32	0.59375	15.081
7/64	0.109375	2.778	39/64	0.609375	15.478
1/8	0.125	3.175	5/8	0.625	15.875
9/64	0.140625	3.572	41/64	0.640625	16.272
5/32	0.15625	3.969	21/32	0.65625	16.669
11/64	0.171875	4.366	43/64	0.671875	17.066
3/16	0.1875	4.763	11/16	0.6875	17.463
13/64	0.203125	5.159	45/64	0.703125	17.859
7/32	0.21875	5.556	23/32	0.71875	18.256
15/64	0.234375	5.953	47/64	0.734375	18.653
1/4	0.250	6.350	3/4	0.750	19.050
17/64	0.265625	6.747	49/64	0.765625	19.447
9/32	0.28125	7.144	25/32	0.78125	19.844
19/64	0.296875	7.541	51/64	0.796875	20.241
5/16	0.3125	7.938	13/16	0.8125	20.638
21/64	0.328125	8.334	53/64	0.828125	21.034
11/32	0.34375	8.731	27/32	0.84375	21.431
23/64	0.359375	9.128	55/64	0.859375	21.828
3/8	0.375	9.525	7/8	0.875	22.225
25/64	0.390625	9.922	57/64	0.890625	22.622
13/32	0.40625	10.319	29/32	0.90625	23.019
27/64	0.421875	10.716	59/64	0.921875	23.416
7/16	0.4375	11.113	15/16	0.9375	23.813
29/64	0.453125	11.509	61/64	0.953125	24.209
15/32	0.46875	11.906	31/32	0.96875	24.606
31/64	0.484375	12.303	63/64	0.984375	25.003
1/2	0.500	12.700	1	1.000	25.400

INCHES INTO MILLIMETRES

Inches	0	1	2	3	4	5	6	7	8	9
0	0	25.40	50.80	76.20	101.60	127.00	152.40	177.80	203.20	228.60
10	254.00	279.40	304.80	330.20	355.60	381.00	406.40	431.80	457.20	482.60
20	508.00	533.40	558.80	584.20	609.60	635.00	660.40	685.80	711.20	736.60
30	762.00	787.40	812.80	838.20	863.60	889.00	914.40	939.80	965.20	990.60
40	1016.00	1041.40	1066.80	1092.20	1117.60	1143.00	1168.40	1193.80	1219.20	1244.60
50	1270.00	1295.40	1320.80	1346.20	1371.60	1397.00	1422.40	1447.80	1473.20	1498.60
60	1524.00	1549.40	1574.80	1600.20	1625.60	1651.00	1676.40	1701.80	1727.20	1752.60
70	1778.00	1803.40	1828.80	1854.20	1879.60	1905.00	1930.40	1955.80	1981.20	2006.60
80	2032.00	2057.40	2082.80	2108.20	2133.60	2159.00	2184.40	2209.80	2235.20	2260.60
90	2286.00	2311.40	2336.80	2362.20	2387.60	2413.00	2438.40	2463.80	2489.20	2514.61

Use in conjunction with above table.

Example: Find equivalent mm. for 84 5/8".

$$84'' = 2133.60 \text{ mm.}$$

$$5/8'' = 15.875 \text{ mm.}$$

$$84 \text{ } 5/8'' = 2149.475 \text{ mm.}$$

CALIFORNIA

Proposition 65 Warning

Diesel engine exhaust and some of its constituents are known to the State of California to cause cancer, birth defects, and other reproductive harm