

WINGET

OPERATION, MAINTENANCE & SPARE PARTS MANUAL

7P (200P) PORTABLE PAN MIXER

HOMETRADE SPECIFICATION

**PUBLICATION No S90
PRINTED NOVEMBER 1975
REPRINTED JUNE 2003**

**WINGET LIMITED
PO BOX 41
EDGEFOLD INDUSTRIAL ESTATE
PLODDER LANE
BOLTON
LANCS
BL4 OLS**

**TEL: ++ 44 (0) 1204 854650
FAX: ++ 44 (0) 1204 854663
service@winget.co.uk
parts@winget.co.uk
www.winget.co.uk**

WINGET

PORTABLE PAN MIXER

7P (200P) HOMETRADE SPECIFICATION

This manual is a reprint of the Winget publication No S90 last printed during November 1975 and is a direct copy of one of the remaining original manuals.

Winget Limited have always operated a policy of continuous product development. Therefore, some illustrations or text within this publication may differ from your machine. The contents of this manual although correct at the time of publication during November 1975, may have been subject to alteration by the manufacturers in the intervening years without notice and Winget Limited can accept no responsibility for any errors or omissions contained within the following pages. Nor can we accept any liability whatsoever arising from the use of this manual howsoever caused.

PUBLICATION S.90.
November 1975

Winget
Limited
Construction Equipment
Division

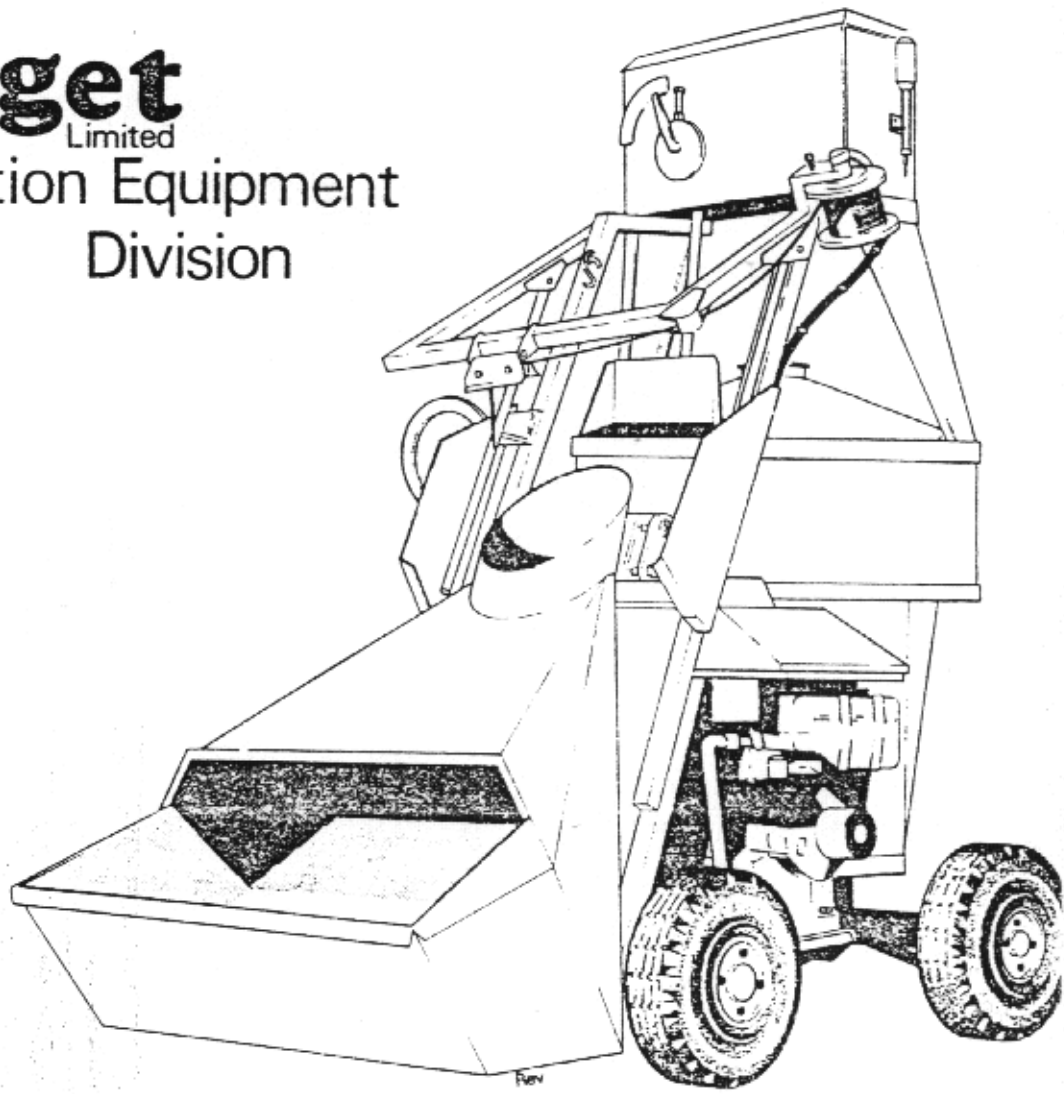

Winget
LIMITED
7P (200P) Home Trade

Operation, Maintenance
and Spare Parts Manual

INTRODUCTION

The operating instructions and maintenance recommendations contained in this book will enable you to become familiar with your mixer to obtain the best results in the shortest possible time.

The life and trouble free running of your machine will depend largely on the care it receives. It is your responsibility to ensure that the maintenance instructions outlined in this book are carried out.

When replacements are required, it is essential that only genuine parts are used and that any repair or servicing work is carried out by competent mechanics.

WINGET LTD.

G U A R A N T E E

The Company will supply free of charge to any destination in the British Isles named in the tender, or F.O.B. British Port in the case of goods situated abroad, any part or parts which, under normal use and service, appears, to the Company's satisfaction, to have been at the time of delivery defective in design, workmanship or material, or at its discretion, the Company will repair such parts, provided it is notified thereof within twelve months or 2,000 working hours from the date of delivery (whichever shall be the earlier) or, where the Company is responsible for erection, within twelve months from the date on which the customer is notified that any plant or machinery is ready for starting up provided that:

- a) Written notice is given to the Company within seven days of the discovery of the defect.
- b) Unless otherwise agreed, the alleged defective part or parts are returned to the Company's works, carriage paid, and its inspection establishes the claim. Replaced parts shall become the property of the Company.
- c) No part which is not of the Company's manufacture has been fitted, otherwise than by it or on its behalf, with its written approval.
- d) No unauthorised alteration or modification has been made to the machine or component the subject of the claim.

In no case shall the Company be responsible for the cost of fitting replacement parts.

Machine parts or components sold by the Company but not of its manufacture are subject to the Guarantee contained herein or such guarantee as is provided by the makers thereof where such guarantee is less than the Guarantee herein contained.

The obligation to repair or replace defective goods herein shall constitute the sole and total liability of the Company whether arising under contract negligence or otherwise for such defective goods or for any loss, damage or injury to any person or any property arising from the defective goods.

This Guarantee is extracted from the Company's standard conditions of sale.

Ensure that the label depicted below is located on your machine.

Winget Limited

SAFETY WARNING

- 1 Before starting this machine, the operator should be familiar with the operating instructions issued by the manufacturer.
- 2 The manufacturer's rated capacity must never be exceeded.
- 3 Before carrying out any maintenance, servicing, or greasing, always ensure that the engine has been switched off. Never work on a machine while it is running.

If the machine is repainted for any reason a replacement label must be obtained from Winget on Spare Part Number 50-46946.

NOTES FOR SAFE OPERATION

1. IMPORTANT

Read the instructions in this handbook together with these notes, and satisfy yourself that you understand all the controls and their function before attempting to operate the machine.

2. BEFORE STARTING THE MIXER

- Check:
- a) That all guards are in position and fitted correctly.
 - b) All control levers are in neutral.
 - c) No one is in or on the machine.
 - d) On electric powered mixers, ensure that the power supply has been correctly connected by a qualified electrician and any trailing cable is protected from damage and not liable to be tripped over.

3. WHEN OPERATING THE MIXER

- a) Do not allow unauthorized persons to climb on or have any part in the operation of the machine.

- b) Do not climb on the machine yourself unless absolutely necessary and then:-
 - (i) Use only the steps and platforms provided.
 - (ii) Keep your clothing clear of any moving parts.
- c) In the case of mixers fitted with loading hoppers, do not allow any person to walk, stand or lean under the hopper when raised.
- d) Where mixers are fitted with drag feeders, do not allow the rope to become snagged around any obstruction or person. Replace ropes as soon as badly frayed.
- e) Do not add fuel, hydraulic oil or lubricate the machine whilst it is running.
- f) If engine housing is fitted keep this closed whilst mixer is running.

4. MAINTENANCE AND REPAIRS

Before starting any work:-

- a) Stop the engine or switch off electric motor, isolate from mains supply and remove fuses.
- b) If working out of sight under the machine or in the drum, try to have a trained person standing by.
- c) Display a warning notice.
- d) Do not work under raised loading hopper unless it is securely chained or propped.

5. ON COMPLETION OF MAINTENANCE

- Check:
- a) That the mixer functions correctly.
 - b) All guards are correctly fitted.
 - c) All control levers are in neutral position.

If you are in any doubt about the safe condition of your machine please consult Winget Limited Service Department.

Description & Operation

LIST OF CONTENTS

<u>PAGE</u>	<u>DESCRIPTION & OPERATING INSTRUCTIONS</u>
1	Transportation of Mixer
1	Anti-Bounce
1	Tyre Pressure
1	Installing your Mixer on Site
1	Transmission
2	Mixer Controls
2	Hopper Control
2	Hopper Operations
2	Discharge Door-hand operated
2	Discharge Door-Power operated
2	Clutch - Optional
2	Operation - Mixing
2	Operation - Discharging
2	Cleaning the Mixer
2	Batch Weigher
2	Normal Operation
2	to "Zero"
3	Water Tank
3	Filling Water Tank
3	Discharging Water Tank
3	Draining the Tank
3	Optional - Water Pump
3	Dragline Feeder
3	Operation
3	Electric Drive Mixers
4	Hopper Loading Arrangements
4	Before Starting Up
4	When Mixing is finished
4	Voltage Setting Instructions
4	Procedure for setting voltage
4	Note
	<u>MAINTENANCE INSTRUCTIONS</u>
6	Lubrication
6	Servicing Frequently
6	General
6	Reduction Gearbox
6	Stauffer Lubrication
6	Oil Change
6	Topping Up
7	Polyvee Vee Belt
7	Clutch
7	Adjustment
7	Lubrication
7	Replacing Sintred Discs
8	Mixing and Scraper Blades
8	Adjustment
8	Fitting New Blades
8	Replacement of Wearing Plates
8	Hydraulic System

Winget

<u>PAGE</u>	<u>MAINTENANCE INSTRUCTIONS</u>	
8	Header Tank	
8	Filling Filter Removal	
8	Cleaning Breather Unit	
8	Cleaning Suction Filter	
8	Dismantling Hydraulic System	
8	Recommended Oils	
9	Water Tank	
9	Batch Weigher	
9	Special Note - Loadcell	
9	Dragline Feeder	
9	Dynamo Belt Adjustment	
9	Lubrication	
9	General Maintenance	
9	Power Operated Door	
9	Lifting Beam	
10&11	Servicing Schedule	
	<u>ILLUSTRATIONS</u>	
-	Dimensional Drawing	Fig. 1
-	General Arrangement	Fig. 2
3	Operation of Water Tank	Fig. 3
4	Wiring and Voltage Setting	Fig. 4
5	Starter Wiring Diagram	Fig. 5
6	Lubrication	Fig. 8
7	Clutch Assembly	Fig. 9

Winget

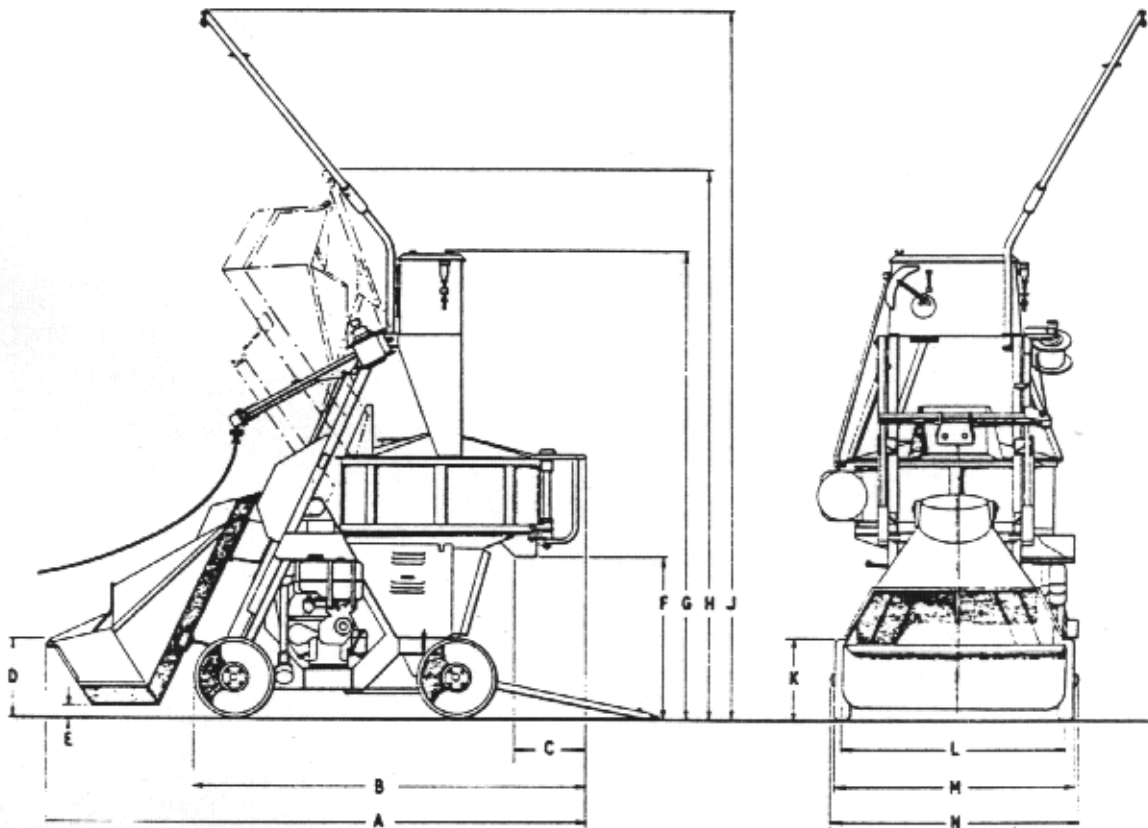

DIMENSIONAL DRAWING

FIG. 1.

A	372 cm	12 ft. 3 in.
B	271 cm	8 ft. 11 in.
C	48 cm	1 ft. 7 in.
D	52 cm	1ft. 9 in.
E	8 cm	3 in.
F	112 cm	3 ft. 8 in.
G	323 cm	10 ft. 7 in.

H	377 cm	12 ft. 5 in.
J	488 cm	16 ft. 0 in.
K	56 cm	1 ft. 10 in.
L	152 cm	5 ft. 0 in.
M	164 cm	5 ft. 5 in.
N	173 cm	5 ft. 8 in.

Approximate weight 2286 kgs (5040 lbs) depending on Drive unit fitted.

Winget

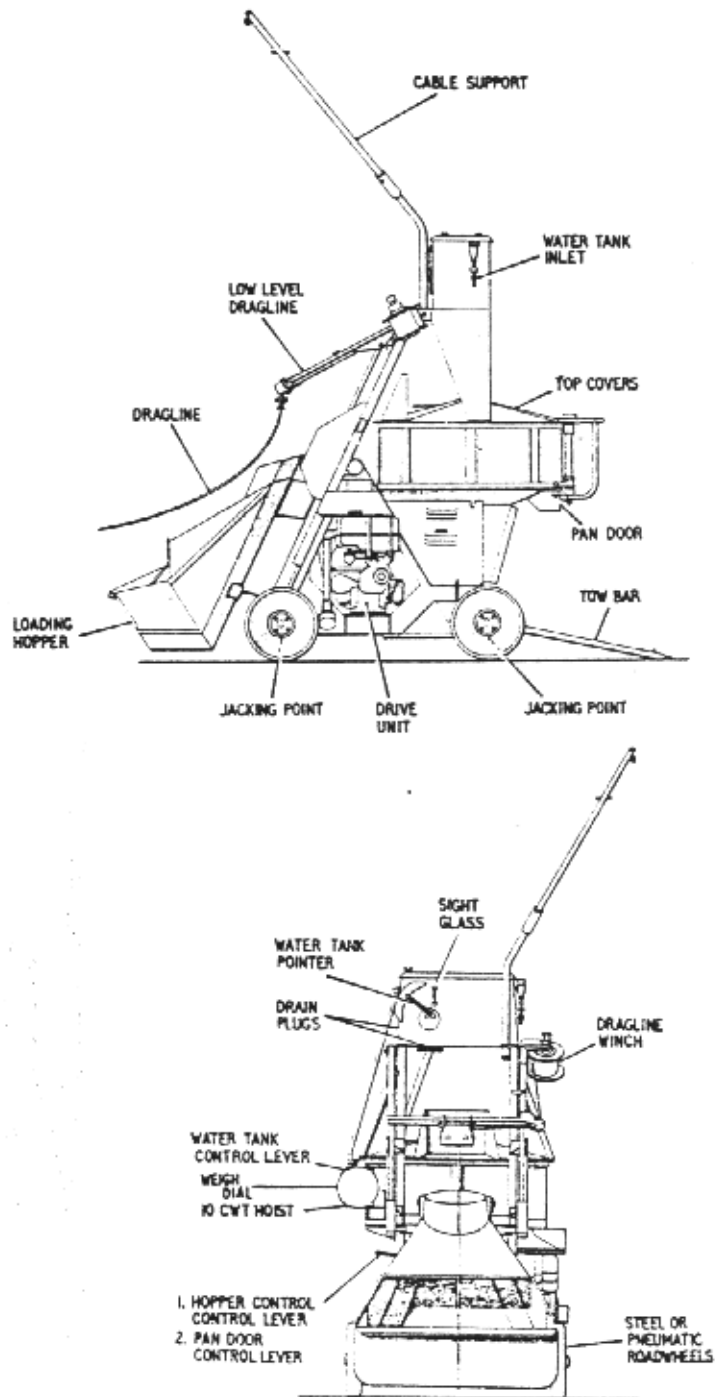

Transportation of Mixer

For the purpose of transporting your mixer to site the water tank has been mounted on the dragline jib. This must be moved back to the working position over the mixing Pan. First move the dragline jib manually into a horizontal position. Remove the hex, head bolts, nuts and spring washers from the stowage brackets and slide the water tank into working position. Secure with existing bolts through six holes provided. Reconnect the outlet pipe to the water tank using two hex, head bolts, nuts, spring washers and gaskets. Also reconnect the tank operating rod, one end to the water control level and the other end to the ram link; replacing washers and split pin one end and Locknut the other.

Anti-Bounce

Anti-bounce bracket and tie bar are supplied as optional extras, to be used when towing a mixer fitted with pneumatic wheels where local regulations allow. The anti-bounce bracket is bolted to the hopper cradle by means of two hex, head bolts, nuts and spring washers, and locked in position to the two jacking tubes welded to the mainframe thus preventing the hopper bouncing when in transit. A tie bar is also supplied to prevent movement of the dragline jib, fixed in position one end with Hex, head bolt, nut and locknut. Using existing hole in guard and upper stop bracket, while the other end is located in a lug attached to dragline jib and tightened down securely using a special locking nut.

Tyre Pressure

If pneumatic wheels are fitted check tyre pressure, regularly, and set at 2.81 Kg/cm² (40 PSI) except when 600-16 RK3A tyre is fitted then set at 3.86 Kg/cm² (55 PSI).

INSTALLING YOUR MIXER ON SITE

- See that your mixer is standing level in both directions with the wheels in line. Check using spirit level along and across weighing links (10-D5). This is necessary if accurate weighing is to be achieved. Remove anti-bounce bracket and tie bar if fitted. Lower jacks (if fitted) with handles provided to take weight off the road wheels, when this is done engage sprags and screw up to lock the front axle and firmly chock the mixer in place. Remove and stow the towing bar, replace drop end pin in front axle. The wheels may now be removed and either stored or fitted to another machine.
- If a batch weigher is fitted, make certain that there are at least 50 mm (two inches) clearance between the ground and the base of the hopper when the loadcell striker is resting on the loadcell striker guide.
- If a dragline feeder is fitted, erect the electric cable support mast.
- Study carefully the engine instruction handbook, before any attempt is made to use the mixer. Check the amount of fuel in fuel tank and especially the level of the lubricating oil in the engine sump. The covers on this machine provide ample ventilation, so keep them in position.
- Remove the hopper safety chain. This is done by turning the engine by hand, with the hopper control lever held in the RAISE position. When the hopper is fully up, release the chain and lower the hopper. (This chain must always be used when transporting the mixer)

DANGER Do not walk, stand or lean under raised hopper unless it is securely chained.

- Check level of the hydraulic oil in the header tank, with the hopper down. Oil should be visible but not more than 12 mm (½") up from the bottom of the filler (15-E5).
- Connect the water supply to the water syphon tank inlet. A gauge glass mounted on the side of the tank will show when the top compartment of the tank is full. Minimum head of water required above the centre of the inlet valve is 1830 mm (6 ft.). The bore of hose to be used must be 25mm (1 in.) minimum with a short run of hose, if continuous working is required.

WARNING Before starting engine ensure water supply has been turned on. Water pump MUST NOT be run dry.

- Assemble the portable feed apron, if one is to be used, placing it squarely in front of the mixer so that the hopper does not foul it when being raised or lowered. The vertical rubber flap is pushed forward by the dragline shovel when charging the hopper, the flap preventing materials from falling between the hopper and ramp. Finally, stake the apron securely in position, using the four picketing lugs on the sides. Extend the centre position of the ramp to separate the aggregate by fitting boards.
- If an electric drive is used, after the circuit has been connected or re-connected, ensure correct direction rotation of motor. This should be in a clockwise direction when viewed from the starter side of the mixer. (ie opposite side to controls)
- Check that the clutch (if fitted) is disengaged before starting the engine.
- Check 1.5 mm to 3.0 mm (1/16" to 1/8") clearance between mixing blades and adjacent wearing plates.
- Plough blades to run on pan centre line.
- Check level of oil in reduction gearbox.

TRANSMISSION

The drive to the reduction gearbox is by a polyvee vee belt from the power unit direct to gearbox, the gearbox having a reduction ratio of 30 to 1. A jockey pulley is mounted on the mainframe allowing adjustment to be made to the polyvee vee belt when necessary. A sintered plate clutch may be fitted as an optional extra. This is mounted on the input shaft of the gearbox and is manually operated. Its advantages are:-

- To reduce wear in allowing the rotor drive to be disengaged during idle periods (only when pan is empty).
 - To disengage the rotor for starting the engine.
 - To allow independent operation of the hydraulic services and dragline winch unit.
- The speed of the rotor is 33. r.p.m. at an engine speed of 1800 r.p.m. (Electric 1450 r.p.m.)

If a diesel engine is fitted to your mixer, read carefully the manufacturer's operating and maintenance manual, a copy of which is supplied with this machine. If an electric drive is used, the motor must be connected to run in a clockwise direction when viewed from the starter side of the mixer. (ie opposite side to controls).

MIXER CONTROLS

Hopper Control

The hydraulic control valve for operating the hopper is located on the mixer on the left hand side looking from the hopper end. The position is illustrated on Fig: 2.

Hopper Operation

To raise the hopper move the control lever upwards as far as it will go and hold it there until the hopper is fully up. Loaded hopper must not be dropped onto the loadcell as this will cause damage to the weighing mechanism. DO NOT hold control in the "Raise" position with the hopper up more than a few seconds or overheating and loss of efficiency will result.

To lower hopper push the control lever downwards; releasing the lever will check the descent of the hopper as necessary.

DISCHARGE DOOR - HAND OPERATED

To open discharge door turn manual door opening handle (9-P2) clockwise and anti-clockwise to close.

DISCHARGE DOOR - POWER OPERATED

To open door move control lever down, and up to close from mid position as indicated. DO NOT hold lever in open or close position when door is at end of its travel in either direction. Intermediate positions of the door may be obtained by releasing the lever when the door is in the desired position.

CLUTCH - OPTIONAL

A side to side control is used to operate the clutch unit coupling the drive unit to the mixing blades. Push the control lever to right to engage and left to disengage drive. It should be noted that the use of the clutch be restricted to engine starting and during idle periods when rotation of the mixing blades are not required. THE PRACTICE OF ENGAGING THE CLUTCH WHEN THE PAN IS CHARGED WITH MATERIAL MUST BE AVOIDED, EXCEPT IN AN EMERGENCY, AS THIS WILL SERIOUSLY OVERLOAD THE TRANSMISSION SYSTEM.

OPERATION—MIXING

It is important that the mixing blades are rotating at their full working speed before material is fed into the pan. It is recommended to reduce mixing time cycle to a minimum, cement, water and aggregate be added to the pan simultaneously. The actual mixing time will vary depending on type of mix, but average time for charge and mix is 45 seconds. THE MIX SHOULD NEVER BE ALLOWED TO REMAIN IN THE PAN FOR MORE THAN TWICE THE MIXING TIME REQUIRED FOR ANY PARTICULAR MIX.

The action of mixing blades and aggregate generates a small amount of heat which will cause water content to drop and consequently stiffen the mix. In event of the mixer stalling, clutch should be disengaged and the power unit re-started to restore hydraulic power to open the discharge door. Stop power unit as a safety precaution, add water to mix and shovel out as much concrete as possible before attempting to re-start mixer.

OPERATION-DICHARGING

Normal discharge is by opening the discharge door and allowing the rotating mixing blades to discharge the concrete.

CLEANING THE MIXER

At the end of each day's work, or if the mixer is standing idle for a period of more than two hours, the mixer should be thoroughly washed out to prevent concrete setting in the pan or on the mixing blades. A CLEAN MIXER IS MORE EFFICIENT, REDUCING THE WEAR ON PAN & MIXING BLADES. Washing down should be carried out as follows:-
Remove top covers, and with the mixing blades rotating, rinse inside of the pan using a high pressure hose pipe. A quantity of gravel added to the pan will assist in a more intensive action. After some minutes open the discharge door and completely empty pan. Stop engine and thoroughly hose down paddle arms to remove all traces of concrete. Check setting of each mixing and scraper blade and adjust if necessary.

BATCH WEIGHER

The weigher gauge is mounted over the drive unit on r.h. side of machine when facing hopper and is connected by hydraulic piping to the loadcell mounted at the front/centre of the main frame.

HYDRAULIC CIRCUIT IS PRIMED AND SEALED ON LEAVING THE WORKS AND ON NO ACCOUNT SHOULD IT BE TAMPERED WITH.

The gauge calibrated from 0.500 kg. (0.1100 lb), gives accurate indication of batch weights. The adjustable coloured pointers mounted on the rim of the gauge can be set by the operator, to the aggregate proportions required. A protective cover is provided for the gauge box to prevent damage when not in use. IT IS IMPORTANT THAT THE MIXER IS STANDING FIRM AND LEVEL AND THAT THERE IS AT LEAST TWO INCHES CLEARANCE BETWEEN THE GROUND AND THE BASE OF THE HOPPER AT ALL TIMES.

If aggregate is allowed to build up around the hopper and weigh gear links an inaccurate gauge reading will be obtained.

NORMAL OPERATION—WEIGHING GAUGE

Set the pointers on the gauge to the aggregate proportions you require. With the engine running, lower the hopper slowly on to the loadcell. Hold the hopper control lever fully down for a few seconds until the gauge needle begins to move up to "ZERO" then release. The hopper is then ready to load.

If you cannot get a "ZERO" reading adjust the gauge as described in the following paragraph:

TO "ZERO" WEIGHING GAUGE

With the mixer engine running proceed as follows

- Lower the hopper on to the loadcell as described.
- Check that the hopper is clear of the ground.
- Taking care not to stand on any part of the hopper or weigh gear links, adjust knurled knob on side of gauge to set the pointer to "ZERO"
- Repeat lowering the hopper three or four times to check that you obtain a consistent "ZERO" reading.

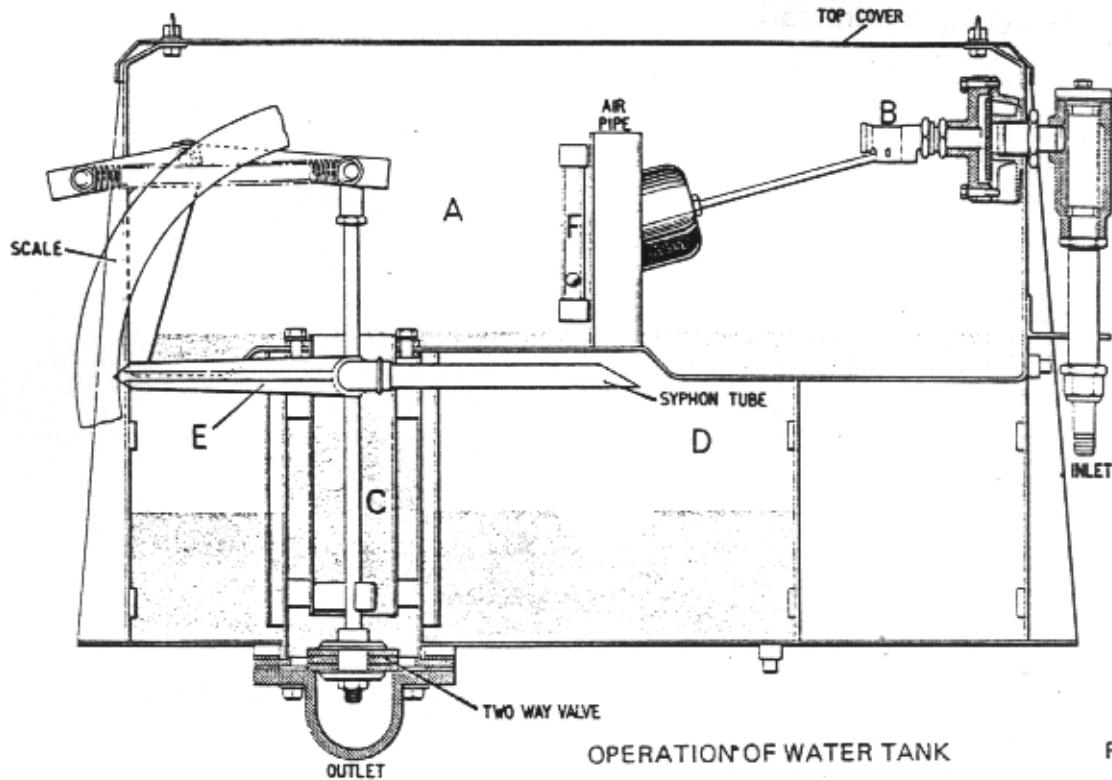

OPERATION OF WATER TANK

FIG. 3.

WATER TANK

The water tank is of the syphon type which automatically measures the required quantity of water, from 7 to 56 litres (1½ to 12 gallons), set by the pointer "A" on the graduated scale at side of tank. The pointer is locked in the desired position by means of a clamp nut. Remember to release this and re-tighten each time the pointer is moved.

FILLING—WATER TANK

The operation of the tank is simple, with the water control lever set in the up position, the tank will automatically fill. Water enters the upper compartment "A" through the inlet valve and strainer unit "B" runs down the syphon cylinder "C" thus flooding the lower compartment "D" until the float lifts, cutting off the main supply. As soon as the indicator float in the sight glass tube "F" begins to rise, sufficient water is available for a measured amount of water to be discharged.

DISCHARGING—WATER TANK

Lower the water control lever which, in turn, lifts the two way valve from its lower seat to stop any further supply of water entering the lower compartment and, at the same time, the required amount of water will be discharged into the mixing drum. After discharging, reset lever.

DRAINING THE TANK

During periods of frosty weather, to avoid damage to the water tank, it is advisable to drain the tank at the end of each day's work. To do this set the pointer at the maximum discharge amount. Drain by disconnecting the mains water supply and operating the water control lever several times and also open the drain tap in the bottom of the tank. Closing it again when the tank is completely empty.

WATER PUMP SHOULD NEVER BE RUN DRY OR THE SEAL MAY BE DAMAGED.

DRAGLINE FEEDER

The winch mounted on the right of the dragline jib is hydraulically driven. The winch is energised via a hydraulic solenoid valve, by a push button switch mounted on the shovel handle. A car type dynamo, belt driven from the engine supplies power to energise the solenoid valve.

DRAGLINE FEEDER—OPERATION

Rig the mixer as shown in Fig. 2 and, with the engine running, pull the shovel back over the aggregate away from the mixer. Depressing the push-switch on the shovel handle will energise the winch and start to drag the shovel towards the mixer. To stop the loaded shovel when it has reached the hopper, simply release the push-switch and tip the contents of the shovel into the hopper.

After rigging the electric control cable, a trial run of the shovel may show that the slack of the electric cable is not taken up by the bottom free pulley as the shovel moves into the mixer. To prevent this increase the size of the weight on the bottom free pulley, if the pulley then comes too close to the ground wind a couple of turns of cable on to the stowage arm on the shovel.

ELECTRIC DRIVE MIXERS

When an electric motor is fitted, it is usual to transport the mixer with the loading hopper propped in the half raised position, as it is not possible to raise the hopper without connecting a supply to the motor. **DO NOT** move prop until electric motor is connected to the supply and normal hydraulic control of the hopper is obtained.

HOPPER LOADING ARRANGEMENTS

It is advisable to use a portable feeding apron or erect a barrier of boards so that materials may be conveniently tipped into the hopper. This is particularly important when using a mixer fitted with a batch weigher, to avoid a build-up of aggregate underneath the hopper.

BEFORE STARTING UP

- Read carefully the engine manufacturer's handbook supplied with the mixer. Check the level of fuel in tank and especially the level of lubricating oil in engine sump.

The covers on this machine provide ample ventilation so keep them closed.

- With the HOPPER DOWN, check the level of the hydraulic oil in header tank.
- Connect the water supply to the water syphon tank inlet. The gauge glass will show you when it is full.

WHEN MIXING IS FINISHED

- Empty and clean out mixing pan with plenty of water.
- Clean out hopper.
- Drain water syphon tank if frost is likely.
- Raise hopper and fix safety chain.
- Stop engine (or electric motor if fitted).
- Wash down outside of mixer.
- Grease up machine for next day's work.

VOLTAGE SETTING INSTRUCTIONS

Start machine. Plug in loading shovel to machine, remove solenoid valve cover and regulator adjusting screw rubber plug, connect a d.c. voltmeter to the two way terminal block inside the valve body, with the aid of a second person to operate the loading

shovel, by depressing the shovel control unit push button. Note the reading on the voltmeter. The correct figure should be 12 volts. If the voltmeter reads in the reverse direction interchange the voltmeter leads.

PROCEDURE FOR SETTING VOLTAGE

If voltage is incorrect then with meter still connected and the loading shovel working, turn voltage regulator adjusting screw situated above connection point 'A' with a small short screwdriver either clockwise or anti-clockwise until meter reads 12 volts constantly after adjustment replace valve cover and regulator plug.

Note:- Do not interfere with adjusting screw above Connection Point 'E'
Optional extra socket voltage will read 15 volts approx. after the above has been carried out.

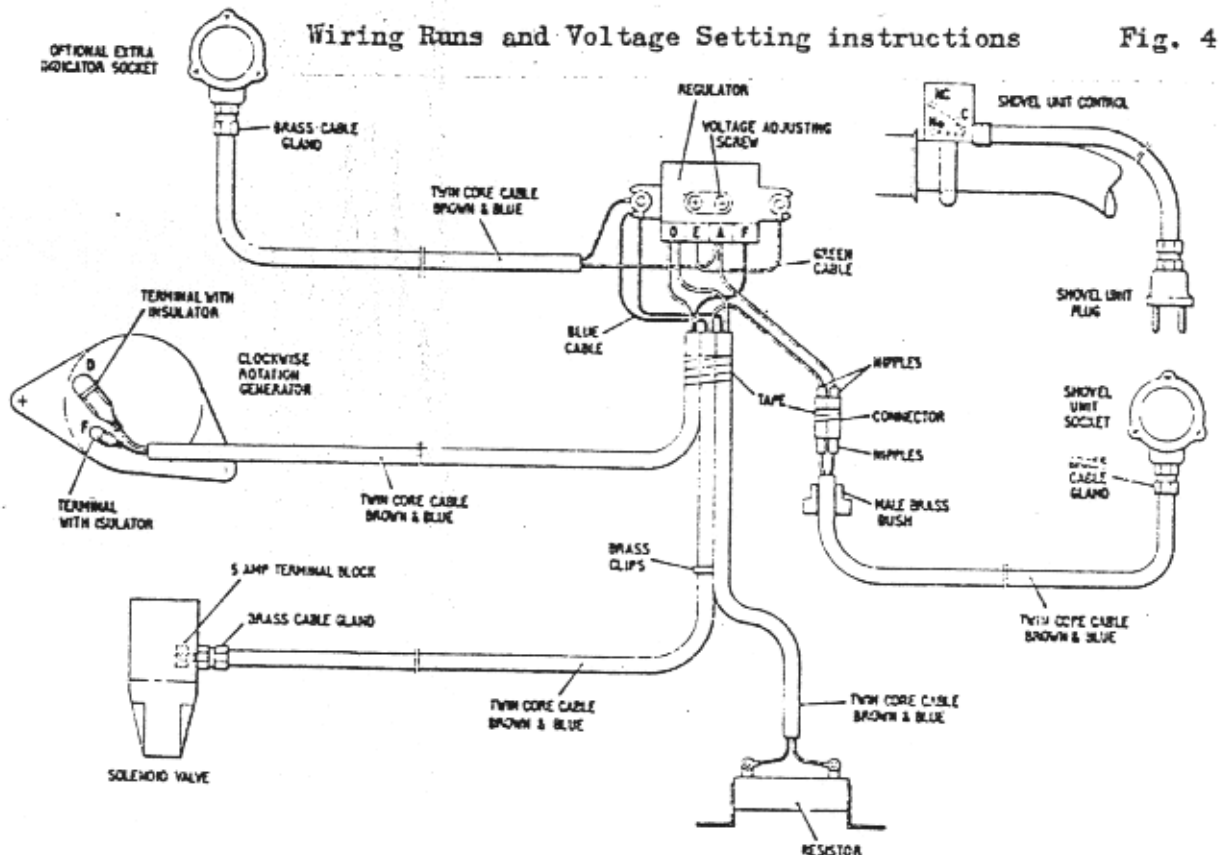

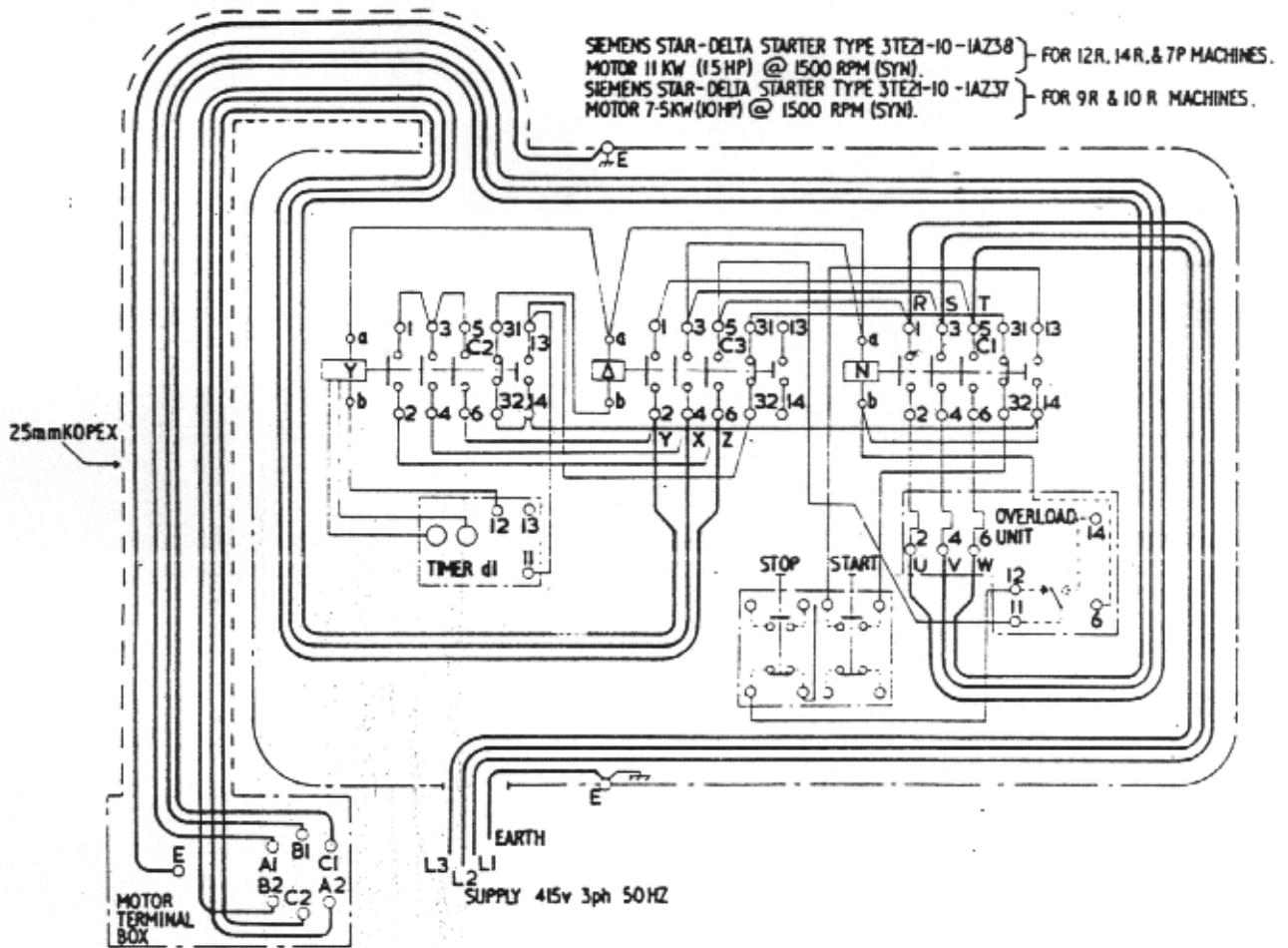

Starter Wiring Diagram Fig. 5

Maintenance

LUBRICATION

SERVICING FREQUENCY

The times quoted in this section i.e. weekly, monthly etc. are based on the following table of running hours:-

DAILY	-	8 RUNNING HOURS
WEEKLY	-	50 RUNNING HOURS
MONTHLY	-	200 RUNNING HOURS
THREE MONTHLY	-	600 RUNNING HOURS
SIX MONTHLY	-	1200 RUNNING HOURS

GENERAL

All shafts and bearings needing daily attention, are lubricated through drilled shafts and special grease-ways by fitting grease nipples. The lubrication diagram Fig. 7 will give you the location of these grease nipples, which should be greased daily, using a grease gun charged with a good quality medium grease (SHELL ALVANIA 2)

It is essential that operators do not allow grease or oil used for servicing to become contaminated with sand or cement dust. At weekly intervals a little engine oil should be applied to pin joints on clutch lever linkage, and low level dragline pivots, etc.

REDUCTION GEARBOX

STAUFFER LUBRICATION—REDUCTION GEARBOX

At weekly intervals the stauffer protruding through the main-frame adjacent to the discharge door chute should be given several turns. Refill SHELL ALVANIA 2. Grease when empty.

OIL CHANGE—REDUCTION GEARBOX

Oil in the gearbox should be changed after the first three months running and subsequently every six months. This is best carried out at the end of a day's work when the oil is warm.

1. Remove drain plug and collect oil in a suitable container-capacity 5.12 litres (9 pints) approx.
2. Refill with SHELL VITREA 79 or equivalent to level.

TOPPING UP—REDUCTION GEARBOX

An extension piece is fitted to the reduction gearbox with a filler tube attached. This is located on the engine side of the mixer. Remove the oil filler cap and top up as necessary until level with top of filler tube using SHELL VITREA 79.

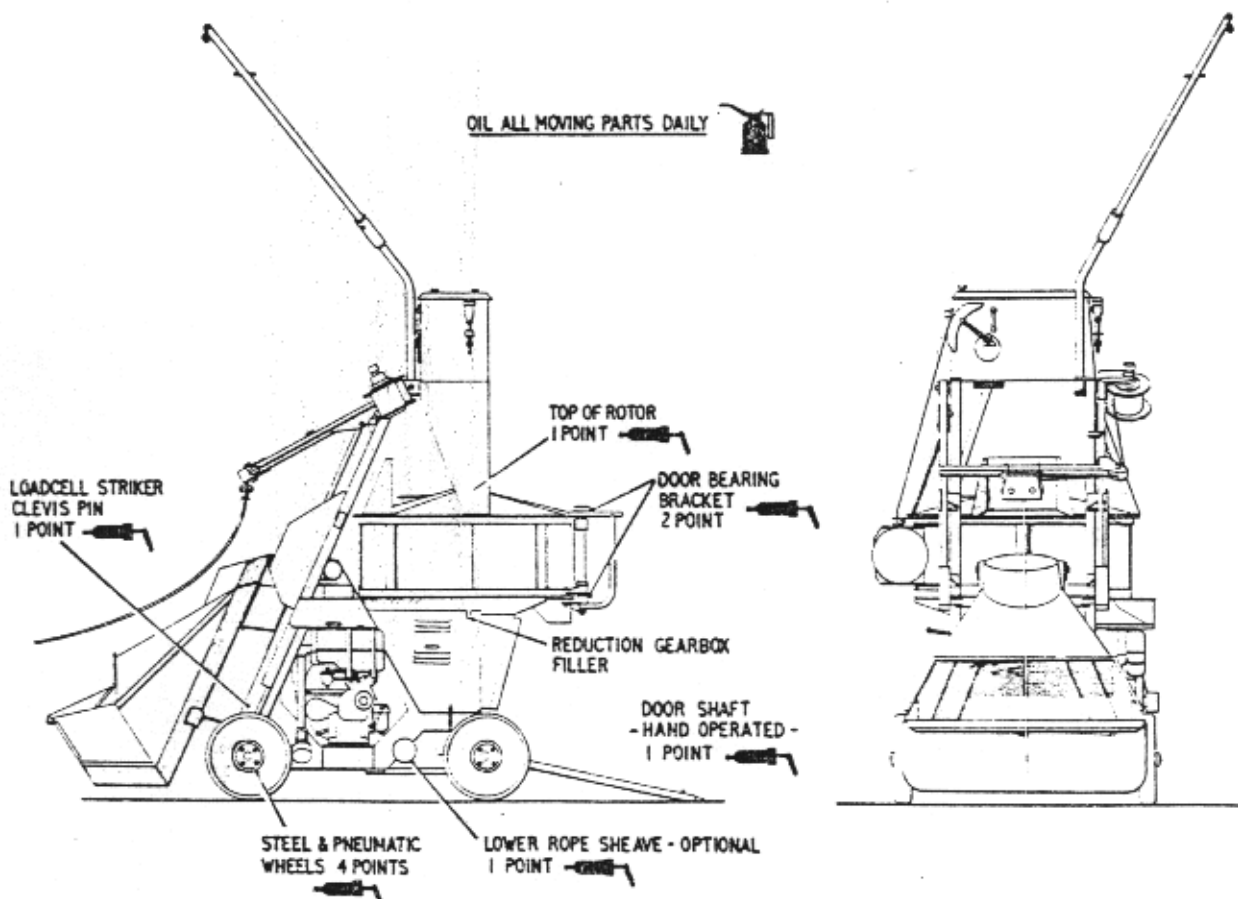

LUBRICATION FIG. 8.

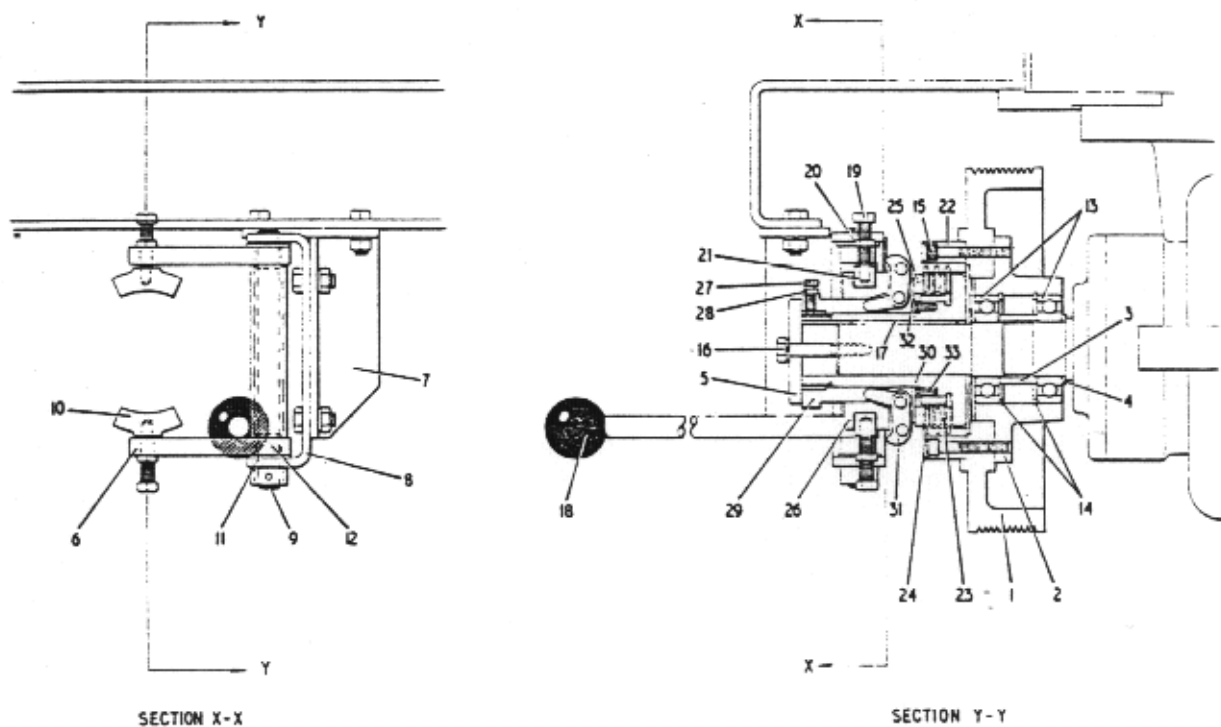

CLUTCH ASSEMBLY

FIG. 9.

POLYVEE VEE BELT ADJUSTMENT

It is important that the tension of Polyvee belts be checked at weekly intervals to ensure efficient power transmission.

An adjusting screw is fitted to the jockey pulley. First slacken off self locking nut on pivot shaft. Allow jockey pulley to move freely along slot in pivot shaft bracket when adjustment is made. Next bring nut and locknut together on adjusting screw and make the necessary adjustment. There should be no free movement in the Polyvee vee belt when adjustment has been made. Finally release nut from locknut and secure in position.

CLUTCH ADJUSTMENT

During running in period, the clutch should be frequently checked, if excessive slipping and overheating are to be avoided. It must be appreciated that in a new clutch (or one fitted with new discs) full driving power will not be reached until discs have bedded in and at the start one or two adjustments may be necessary to achieve this after which normal checks can be adopted.

To adjust clutch ref. to fig. 8 slacken off the locking screws (27) and turn the adjusting bush (29) clockwise until the required torque capacity is obtained. A correctly adjusted clutch will require only a moderate force on the operating lever. Attach a spring balance to the operating knob and check pull necessary to engage clutch this should be 11.3 Kgs. (25 lbs). When this has been done it is vitally important that the locking screws be tightened into the

bottom of the nearest serrations in the centre (30) and locked in that position, merely tightening on top of the serrations may result in serious damage to the clutch.

LUBRICATING-CLUTCH

The toggles, and the sleeve should be lightly smeared with grease but the amount used should be only sufficient to prevent the moving parts from running dry leading to seizure. On no account must any form of lubricant be allowed to come in to contact with the friction discs.

REPLACING SINTRED DISCS

1. First release lock nuts (20) and slacken off tappet screws (19) and remove tappet brasses (21).
 2. Remove setscrew (16) and clutch shaft cap (5)
 3. Withdraw split pin and drop clutch operating pin (9) Thus releasing clutch operating arm (8).
 4. Remove capscrews (15) and withdraw clutch unit from wormshaft.
 5. Place the clutch unit on a clean bench surface, and unscrew adjusting bush (29) also removing sleeve (26).
 6. Withdraw the pressure plate (32) three springs (33) and front plate (25).
 7. Withdraw the three sintred discs (24) and spacer plates (23) Inspect and replace sintred discs if necessary. At this stage it would also be advisable to consider replacing tappet brasses (21).
- Reverse this procedure for re-assembling.

MIXING AND SCRAPER BLADES ADJUSTMENT

Blades should be inspected daily for wear and adjusted if necessary to 1.5 mm to 3 mm (1/16" to 1/8") clearance between blade and bottom or side of pan as follows:-

1. Open discharge door and stop engine. Turn engine by hand with clutch engaged until the blade to be checked is adjacent to door opening.
2. Slacken blade fixing bolts to check alignment and retighten.
3. Slacken two setscrews on blade arm clamp. First check position of blade from centre of rotor, secondly make any necessary adjustment to blade clearance by tapping the end of paddle blade support until the correct clearance is obtained between blade and wearing plate. Retighten fixing bolts and setscrews securely.
4. After adjustment has been made, it is recommended that as a final check before running the drive unit, the rotor housing be rotated several times to ensure the blades do not foul the pan.

FAILURE TO MAINTAIN BLADES IN CORRECT ALIGNMENT WILL RESULT IN CONSIDERABLE WEAR TO BOTH BLADES AND WEARING PLATES.

FITTING NEW BLADES

Badly worn blades should be renewed as follows:-

1. Open discharge door and stop engine. Turn engine by hand, with clutch engaged, until the worn blade is over door opening.
2. Detach worn blade by removing the two fixing bolts, securing it to the blade support.
3. Fit new blade and tighten up after adjustment has been made.
4. Turn rotor to check that blade does not foul pan.

REPLACEMENT OF WEARING PLATES

To assist in replacement of either the inner, outer or bottom wearing plates, they have been divided into easily removable sections.

long life.

1. Remove a paddle arm support and paddle blade as previously described and turn engine by hand, with clutch engaged until the empty rotor arm is over the wearing plate to be removed.
2. If bottom wearing plates are to be removed, remove side cover to obtain access to counter sunk setscrews.
3. Remove counter sunk fixing screws and worn plates from machine. Refit new plates ensuring good seating scraping off any deposit of concrete built up locally around edge of the area covered by the old wearing plate.
4. Re-assemble mixing blades and check clearances.
5. Operate discharge door and adjust sealing strip-lock in position.

HYDRAULIC SYSTEM HEADER TANK

Ensure that the Hopper is FULLY DOWN and the engine STOPPED. Top up as necessary with oil of recommended grade, do not mix different grades of oil and clean around filler cap before removal. This is located inside the main frame on the side of the mixer opposite to the engine. Once a week check that the oil level in the tank is visible but no more than 12 mm (1/2") up from the bottom of the filter (15-E5)

FILLING FILTER REMOVAL—HYDRAULIC

The tank is provided with a cylindrical filter which filters the hydraulic oil when filling or topping up the system. This filter is combined with a breather unit which is incorporated in the filter cap. The filter should be removed once every three months for inspection, this can be carried out without draining the tank as follows:-

- a) Clean the top of the tank and remove the filter cap/breather unit.
- b) Unscrew the six self tapping screws securing the filter to the tank.
- c) Remove filter. Cover the opening with a clean rag whilst filter is removed.
- d) Thoroughly clean the filter in petrol, and air dry well before reassembly.
- e) Remove rag and replace filter and self tapping screws.
- f) Top up with oil if necessary and replace cap/breather unit.

CLEANING BREATHER UNIT—HYDRAULIC

The breather in the cap on top of the filling filter should be washed in petrol every month and air dried thoroughly before re-fitting. Keep opening in tank covered with clean rag while cleaning breather.

CLEANING SUCTION FILTER—HYDRAULIC

The suction filter is located at the bottom of the hydraulic tank, this should be removed and cleaned in petrol ONLY when carrying out a complete machine overhaul.

DISMANTLING HYDRAULIC SYSTEM

Do not remove or expose any part of the internal hydraulic gear in the event of a breakdown unless instructed to do so. If you do, this may lead to further complications in correcting the fault. Remember that you have a "WINGET" Service Depot near you which is always ready and willing to help.

RECOMMENDED OILS HYDRAULIC

The capacity of the system is approximately 22 litres (5 gallons) and is filled at the works with SHELL TELLUS 29 for use in temperatures up to 90°F or TELLUS 33 in temperatures above 90°F. The particular grade shown on a label attached to the top of the header tank.

WATER TANK

Remove top cover every month. Clean and grease valve mechanism.

BATCH WEIGHER

To ensure maximum efficiency, keep the weighing mechanism as clean as possible, avoid build-up of material around link pivots (10-D1). Do not allow aggregate to accumulate on the ground under the hopper.

SPECIAL NOTE:

ON NO ACCOUNT MUST THE LOADCELL BE DISCONNECTED FROM THE WEIGHING DIAL. NO RESPONSIBILITY WILL BE TAKEN IF THE LEAD SEALS WHICH ARE ATTACHED TO THE PIPE UNIONS ARE BROKEN.

DRAGLINE FEEDER

Check dynamo brushes periodically. The regulator cut-outs should be maintained at 12½ to 13 volts. If the electric cable (25-G1) to the shovel needs repair it should not be shortened to less than 20 metres (65 feet).

DYNAMO BELT ADJUSTMENT

Slacken the two setbolts on the dynamo adjusting link (I-J1) and the two bolts securing the dynamo to its mounting bracket (2-J1) Pivot the dynamo until the drive belt is correctly tensioned, then re-tighten all bolts securely.

LUBRICATION

Grease nipples provided are shown in Fig. 6. Include these in your daily servicing.

GENERAL MAINTENANCE

Keep the mixer clean. Check for tightness, from time to time, and especially during the first few weeks of operation all bolts, nuts, keys, etc. Particular attention should be paid to engine fixing bolts. Clean top of header tank before removing filler cap or filter. Add oil of recommended grade only, through the filter provided. Drain water syphon tank during frosty weather. Lubricate all moving parts each night ready for the next day's working.

POWER OPERATED DOOR

Ensure the ram is set up to maintain a clearance between stop on pan door and welded distance pieces on the chute. This must be checked by moving the door physically not under power. Failure to do so may result in cracked door casting.

LIFTING BEAM

A lifting beam can be obtained to simplify the method of removing the engine. The lifting beam is bolted horizontally across the dragline and water tank support frames with the overhang on the engine side.

TO REMOVE ENGINE.

1. Ensure hopper is in the down position.
2. Remove fuel tank cover assembly complete with air cleaner.
3. Prop up fork end of jib struts on lower stop brackets.
4. Unbolt upper stop brackets and dragline guards from support frames.
5. Bolt lifting beam to support frames by lower lugs with overhang on engine side.
6. Place traveller assembly onto beam and secure stop bolt in position on end of beam.
7. Suspend lifting gear from traveller assembly.
8. Disconnect all mountings and connections to engine.
9. Position lifting gear around engine securely.
10. Lift engine and pull clear of machine along beam.

SERVICING SCHEDULE

DAILY

MIXER	Lubricate daily through grease nipples using a good quality medium grease. Alvania Grease 2 is used at works—see lubrication diagram. Thoroughly clean out mixing pan when mixing is finished, with water and gravel. Wash out hopper and hose down mixer.
MIXING AND SCRAPER BLADES	Inspect for wear and adjust to give 1.5 mm to 3.00 mm (1/16" to 1/8") clearance between bottom and side of pan. See page 8
ENGINE SUMP LUBRICATION FUEL TANK	See Engine Handbook

NOTE

IT IS IN THE USERS OWN INTEREST TO MAINTAIN ENGINE AIR, LUBRICATING OIL AND FUEL FILTERS AT THE MANUFACTURER'S RECOMMENDED INTERVALS, TOPPING UP WITH CLEAN OIL AND FUEL FROM CLEAN CONTAINERS AS NECESSARY. RUNNING THE ENGINE WITH DEFECTIVE AIR OR OIL FILTERS WILL RESULT IN RAPID WEAR, HIGH RUNNING COST AND LOSS OF RELIABILITY.

WEEKLY

REDUCTION GEARBOX	Check oil level, for location See Fig. 6
HYDRAULIC HEADER TANK	Clean top of tank—remove filler cap and check level. Check with hopper down and engine stopped.
DRAGLINE	Check belt tension, adjust if necessary.
POLYVEE ADJUSTMENT	Check tension of vee belt as described on page 7
ROTOR CLUTCH	Grease operating tappet brasses. Attach a spring balance to the operating knob and check pull necessary to engage clutch, this should be 11.3 kgs. (25 lbs). Give Stauffer one turn. (Wormbox)

WEEKLY

GENERAL	Apply a little engine oil to pin joints on water tank controls, axle pivots etc. Check two screws on hydraulic valve (hopper)
----------------	--

MONTHLY

BREATHER FILTER ON HYDRAULIC TANK	Remove breather filter and rinse in clean petrol, air dry thoroughly before refitting. Cover aperture while filter is being cleaned.
--	--

THREE MONTHLY

REDUCTION GEARBOX	Change oil after first three months operation and subsequently every six months—see below.
HYDRAULIC HEADER TANK FILLING FILTER	Remove, clean and inspect See page 8

SIX MONTHLY

BREATHER FILTER ON HYDRAULIC TANK	Renew Breather Filter.
REDUCTION GEARBOX	Drain and refill. See page 6

EQUIVALENT GRADES OF OIL

APPLICATION	SHELL	BP	ESSO	MOBIL	CASTROL
Worm Box	Vitrea Oil 79	Energol CS550	Teresso140	Mobil Gear 632	Alpha 717
Hydraulic System—up to 90°F	Tellus Oil 29	Energol HLP80	Nuto H.54	Mobil D. T. E. 25	Hyspin AWS 32
Hydraulic System—above 90°F	Tellus Oil 33	Energol HLP100	Nuto H.54	Mobil D. T. E. 26	Hyspin AWS 68
Grease Points	Alvania Grease 2	Energrease LS2	Beacon 2	Mobilplex 47	Spherol APT 2

NOTE:- In the above we list the lubricant specifications as recommended by various companies. These are intended as a guide only and should your site conditions be in any way abnormal your local oil supplier should be consulted.

Spares

Please note that a number of components are described as being c/w screws, nuts and washers, this is no longer the case and all fixings should be ordered separately if required. Imperial fixings may no longer be available and the nearest metric equivalent will be supplied.

Winget

TO FIND A SPARE PART

The assemblies have been divided into groups and given identification letters A.B.C. etc. To identify a component, first find the relevant assembly in the list given on next page, this will give you a group letter to turn to. On turning to this group the illustrations will enable you to identify the part you required and give you a reference number. Against this number in the Parts List will be found the DESCRIPTION and PART NUMBER information which we require.

To avoid delays and errors, remember always to quote :-

THE MACHINE NUMBER

— which will be found stamped on a plate at the side of the machine

DON'T RISK DELAYS AND ERRORS

REMEMBER

ALWAYS QUOTE

THE SERIAL NUMBER

OF THE MACHINE

WINGET LIMITED			
ROCHESTER — KENT — ENGLAND			
SIZE OF MIXER	<input type="text"/>	YEAR MADE	<input type="text"/>
MIXING R.P.M.	<input type="text"/>	WT. <input type="text"/>	CWTS. <input type="text"/> QRS <input type="text"/>
RELEVANT B.S.S.	<input type="text"/>	PATENT NO.	<input type="text"/>
WHEN ORDERING SPARES			<input type="text"/>
QUOTE MACHINE NO :-			

AND THE ENGINE NUMBER



Group	Description
A4	Mainframe, Pan Wearing Plates and Guards
A5	Portability with Steel Wheels
A6	Portability with Pneumatic Wheels
B13	Rotor and Blades
B14	Pan Covers
D5	Cradle, Hopper, Loadcell and Gauge
E5	Hydraulic Tank
E6	Hopper Ram up to Ram No. 8200
E7	Control Valve
E8	Dragline Control Block
E10	Basic Hydraulic Circuit
E11	Basic Hydraulic Circuit with Dragline
E15	Basic Hydraulic Circuit with Dragline and Power operated Pan Door
E16	Basic Hydraulic Circuit with Power operated Pan Door
E18	Pan Door Ram
E21	Cessna Control Valve Assembly
E22	Cessna Control Valve Fixings
E23	Hopper Ram from Ram No. 8201
E	Identification of Hydraulic Fixings
F3	Water Tank Mechanism
F10	Water Tank
F11	Water Tank Controls
F12	Water Pump used when water meter is fitted
F13	Water Pump with Washdown only
F15	Washdown System without water meter
F17	Water Pump and Water Meter
G1	Dragline
G2	Anti-bounce
H3	MK II Hydraulic Winch and Hoist Mechanism
H4	MK III Hydraulic Winch and Hoist Mechanism
J2	Dynamo Drive Assembly
K2	Compressor Drive - Optional
L11	Lister SR3 Diesel Drive Assembly
L12	Petter PH2 Diesel Drive Assembly
L13	Electric Drive Assembly
M1	Wiring Diagram
N1	Worm Reduction Unit
P1	Discharge Door Hand and Power Operated
P2	Discharge Door Operation Hand and Power Operated
Q1	Clutch
R1	Jockey Pulley
S1	Drive Bearing Bracket and Pump Mounting
U1	Dragline Loading Ramp
V2	Mixer with Portasilo

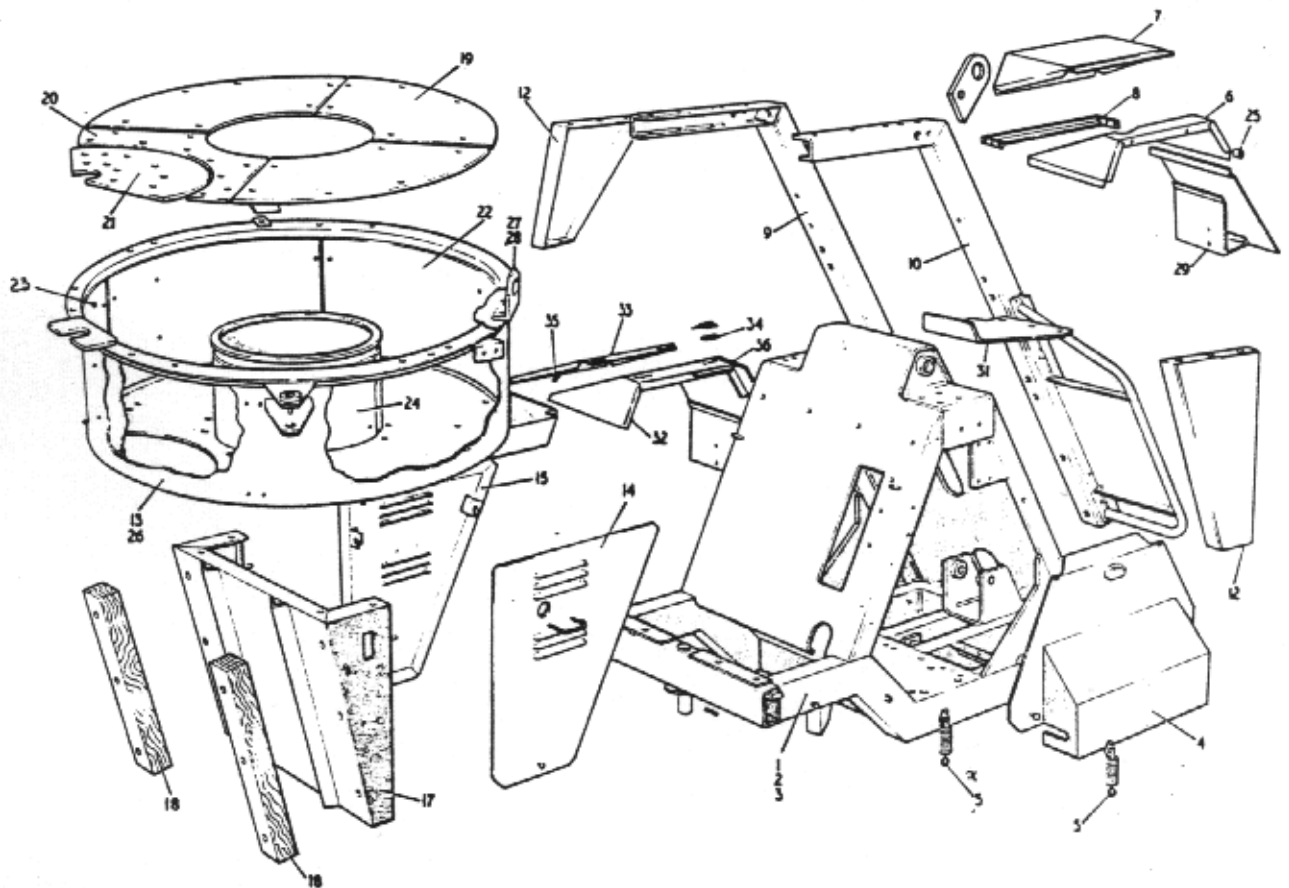

Ref No	Description	Part No	Qty
1	Mainframe (Basic)	555-1579	1
2	*Mainframe for Non-Weigher Machines used with (Basic) Mainframe 555-1579	555-1096	1
3	*Mainframe for Pneumatic Wheels & Manual Jacking Optional used with (Basic) Mainframe 555-1579	555-1026	1
4	Control side Cover	555-1315	1
5	Bonnet Clip	221-101000	4
6	Fuel Tank Shroud complete with	555-1284	1
	Hex Head Bolt	460-506100	1
	Hex Head Bolts	460-506060	4
	Hex Head Bolts	460-506080	2
	Hex Head Bolt	460-506280	1
	Hex Nuts	331-850600	8
	Spring Washers	464-306000	8
7	Engine Fuel Tank Cover complete with	555-1286	1
	Hex Head Bolt	460-506060	1
	Hex Nut	331-850600	1
	Spring Washer	464-306000	1
8	Back Stop for Fuel Tank Cover	555-1285	1
9	Dragline & Water Tank Support Frame (R.H.) complete with	555-1456	1
	Hex Head Bolts	460-350830	3
	Hex Head Bolts	460-350812	3
	Hex Nuts	330-350800	6
	Spring Washers	464-308000	6
	Plain Washers	463-308000	3
10	Dragline & Water Tank Support Frame (L.H.) complete with	555-1457	1
	Hex Head Bolts	460-350830	3
	Hex Head Bolts	460-350812	3
	Hex Nuts	330-350800	6
	Spring Washers	464-308000	6
	Plain Washers	463-308000	3

S.83 October 1972

MAINFRAME, PAN, WEARING PLATES & GUARDS

*When Ordering these items the Basic Mainframe No.1 must always be Quoted too.

When Ordering Always Quote: — Machine No Part No Description Quantity

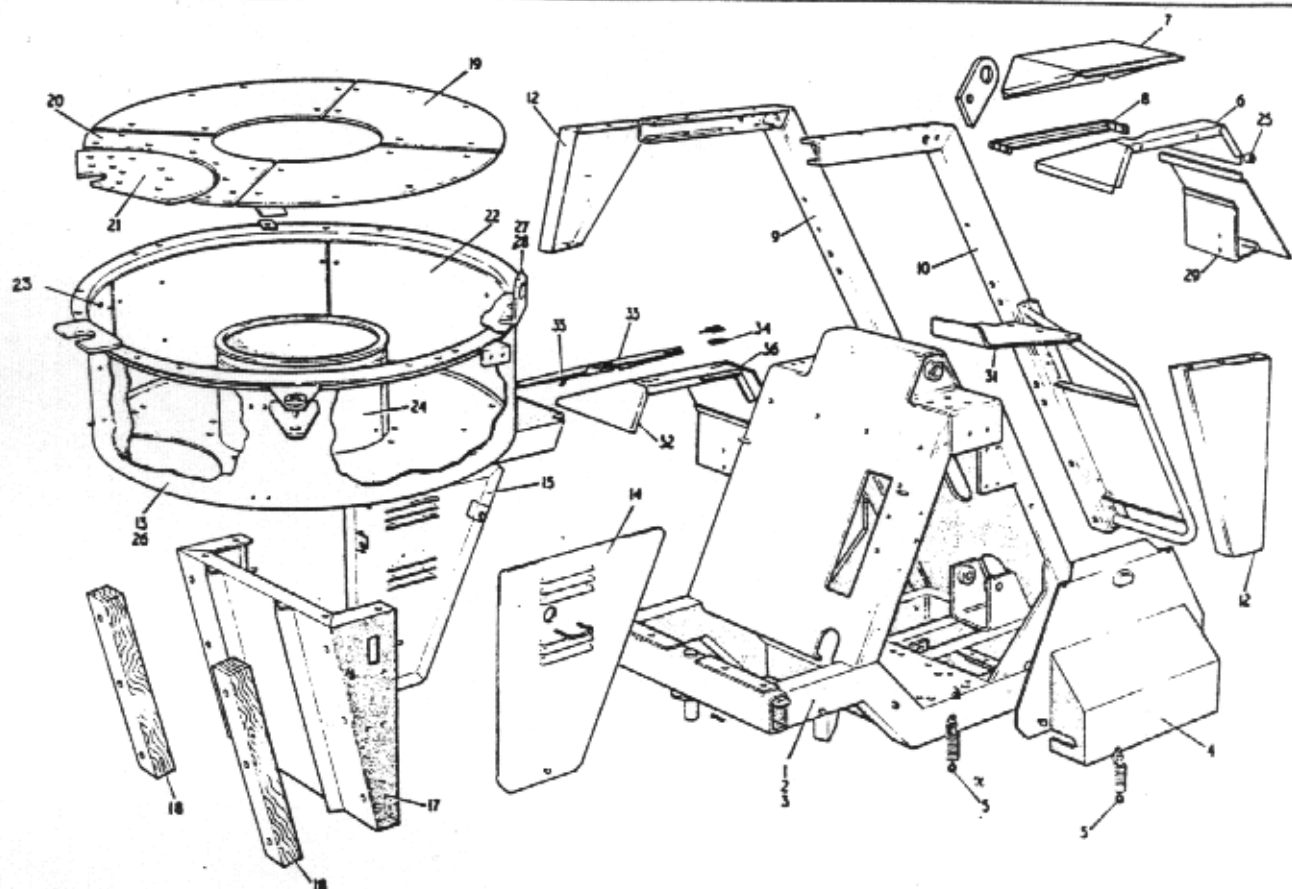

Ref N ^o	Description	Part N ^o	Qty
11	—	—	—
12	Water Tank Support complete with Hex Head Bolts Hex Nuts Spring Washers	555-1604 460-350810 330-350800 464-308000	1RH 1LH 4 4 4
13	Mixing Pan (Power Door) complete with Hex Head Bolts Hex Nuts Spring Washers	555-1580 460-350810 330-350800 464-308000	1 4 4 4
14	Side Panel L.H.	555-1584	1
15	Side Panel R.H.	555-1585	1
16	—	—	—
17	Pedestal for Pan complete with Hex Head Setscrews Spring Washers Hex Head Bolts Hex Nuts Spring Washers	555-1386 418-250806 464-308000 460-350608 330-350600 464-306000	1 4 4 6 6 6
18	Wooden Buffers complete with Coach Bolts Hex Nuts Spring Washers	512-1334 461-556160 331-850600 464-306000	2 6 6 6
19	Pan Bottom Wearing Plate complete with Csk Head Setscrews Hex Nuts Spring Washers	555-15821 400-15822 330-350800 464-308000	3 18 18 18
20	Pan Bottom Wearing Plate Around Door inlet complete with Csk Head Setscrews Csk Head Setscrews Hex Nuts Spring Washers	555-15822 400-158320 400-158220 330-350800 464-308000	1 6 4 10 10

S.83 October 1972

MAINFRAME, PAN, WEARING PLATES & GUARDS

*When Ordering these items the Basic Mainframe No.1 must always be Quoted too.

When Ordering Always Quote :- Machine N^o Part N^o Description Quantity

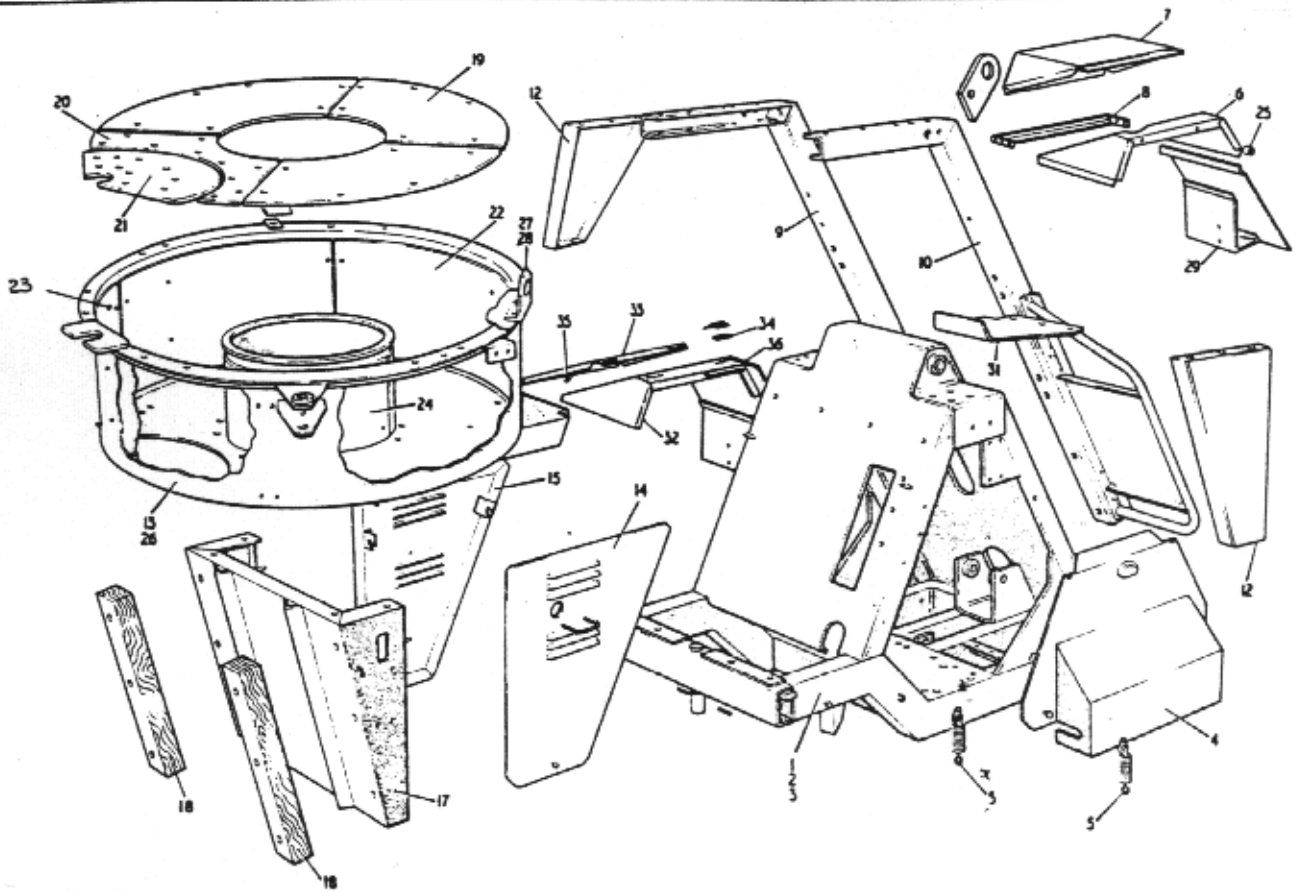

Ref No	Description	Part No	Qty
21	Door Wearing Plate complete with Csk Head Setscrews Hex Nuts Spring Washers	555-15823 400-156260 330-350600 464-306000	1 10 10 10
22	Pan Outer Wearing Plates complete with Csk Head Setscrews Hex Nuts Spring Washers	555-15832 400-156180 330-350600 464-306000	3 18 18 18
23	Pan Outer Wearing Plates Door complete with Csk Head Setscrews Hex Nuts Spring Washers	555-15832 400-156180 330-350600 464-306000	1 6 6 6
24	Pan Inner Wearing Plates complete with Csk Head Setscrews Hex Nuts Spring Washers	555-1592 400-156180 330-350600 464-306000	2 12 12 12
25	Distance Piece	555-1700	1
26	Mixing Pan (Hand Door) complete with Hex Head Bolts Hex Nuts	555-1580/ 555-1874 460-350810 330-350800	1 4 4
●27	Lifting Lug complete with Hex Head Bolts Binx Nuts Plain Washers	555-1842 460-350812 335-760800 463-308000	2 4 4 4
●28	Square Washer	463-408000	1
	Machine Less Water Tank and Dragline ●		

S.83 October 1972

MAINFRAME, PAN, WEARING PLATES & GUARDS

*When Ordering these items the Basic Mainframe No.1 must always be Quoted too.

When Ordering Always Quote — Machine No, Part No, Description & Quantity

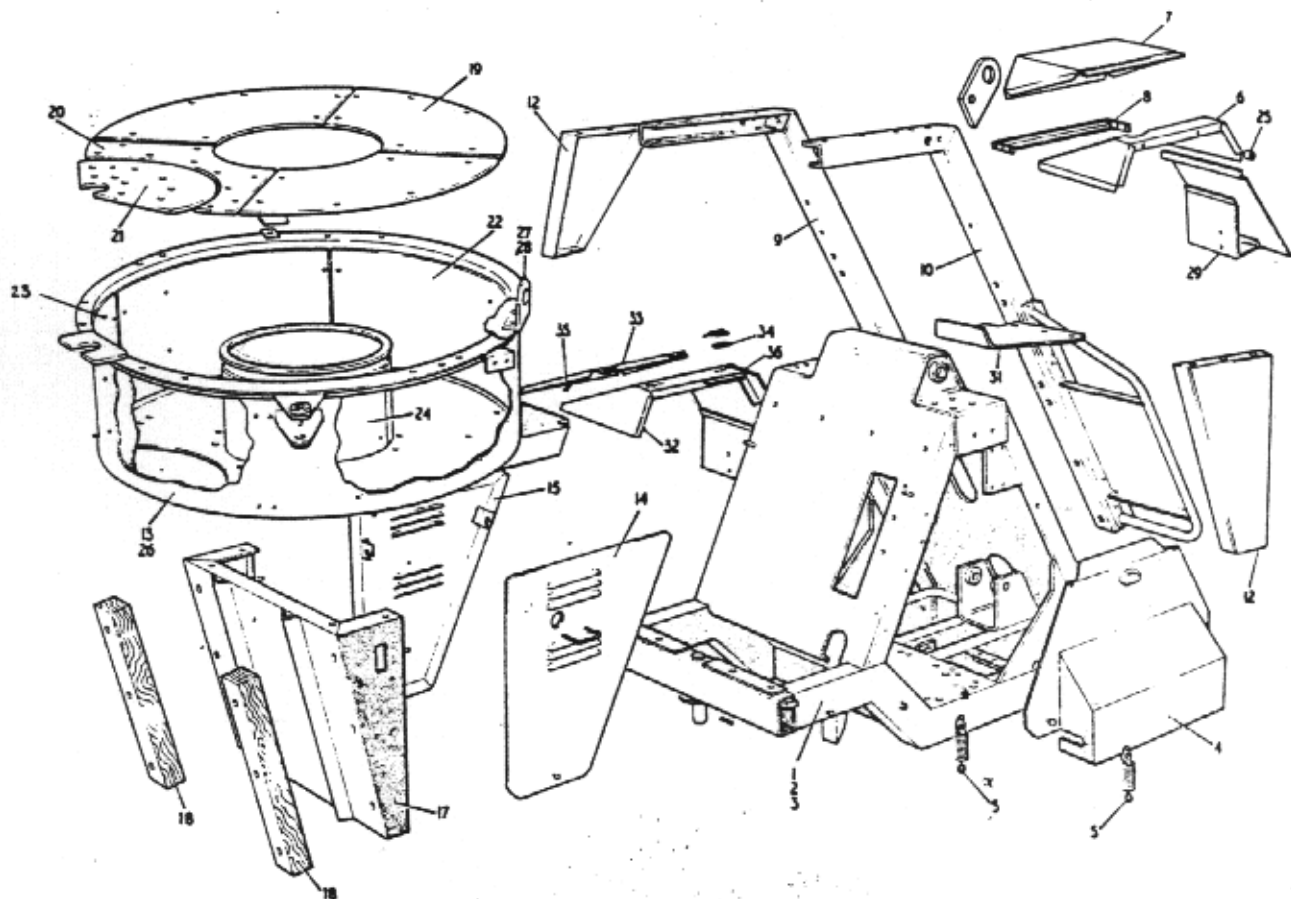

Ref N ^o	Description	Part N ^o	Qty
29	Fuel Tank Cover Extension	555-1883	1
30	Fence complete with	555-1899	1
	Hex Head Setscrews	418-250606	6
	Spring Washers	464-306000	6
31	Step complete with	555-1904	1
	Hex Head Bolts	460-350812	2
	Hex Nuts	330-350800	2
	Spring Washers	464-308000	2
	Plain Washers	463-308000	2
32	Fuel Tank Shroud complete with	555-1931	1
	Hex Head Bolts	460-506100	1
	Hex Head Bolts	460-506080	2
	Hex Nuts	331-850600	3
	Spring Washers	464-306000	3
33	Hinged Fuel Tank Cover complete with	555-1932	1
	Csk Head Screws	400-810060	6
	Hex Nuts	342-910000	6
	Spring Washers	464-280000	6
34	Packers	555-1933	2
35	Latch for Hinged Fuel Tank Cover complete with	555-1934	2
	Hex Head Bolts	460-504060	1
	Hex Nuts	335-760400	1
	Plain Washer	463-304000	1
36	Foam Rubber Cord	394-414000	1
			Lgth.

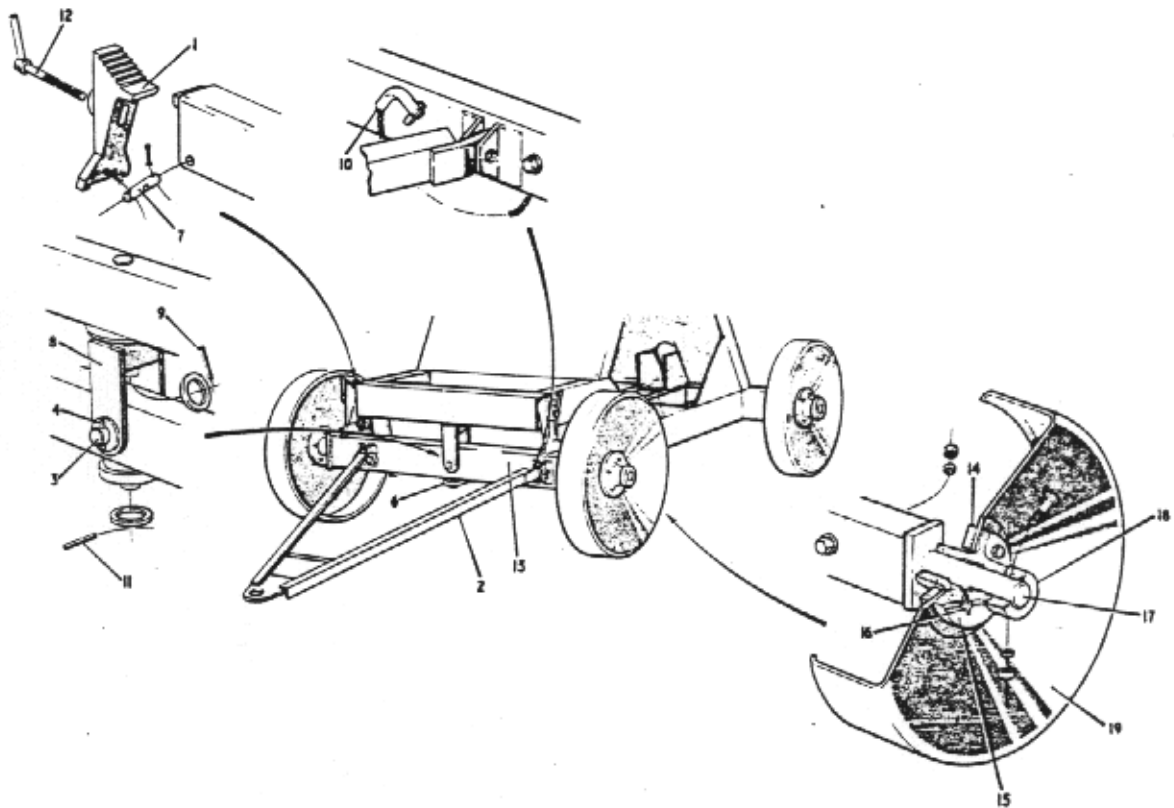

Ref N ^o	Description	Part N ^o	Qty
1	Axle Sprags	555-1011	2
2	Towbar	555-1012	1
3	Axle Pivot Pin	555-1014	1
4	Sel-Lock Pins complete with Plain Washers	353-803320 463-320000	2 2
5	—	—	—
6	Axle Tie bar	555-1016	1
7	Sprag Pins complete with Split Pins	555-1017 353-304160	2 4
8	Axle Pivot	555-1019	1
9	Sel-Lock Pin complete with Plain Washer	353-806320 463-324000	1 1
10	Towbar Drop End Pins	555-1021	2
11	Sel-Lock Pins complete with Plain Washers	353-803240 463-316000	2 2
12	Sprag Retainers complete with Heavy Plain Washers	555-1018 463-410000	2 2
13	Front Axle	555-1027	1
14	Backing Plates	511-1654	4
15	Wheel Hubs	511-1438	4
16	Straight Nipples	333-104200	4
17	Stub Axles complete with Hex Hd Bolts Hex Nuts Spring Washers	555-1023 460-350830 440-350800 464-308000	4 4 4 4
18	Collars complete with Hex Hd Bolts Hex Nuts Spring Washers	145-504000 460-350630 330-350600 464-306000	4 4 4 4
19	Road Wheels complete with Hex Hd Bolts Hex Nuts Spring Washers	511-1467 460-351016 330-351000 464-310000	4 16 16 16

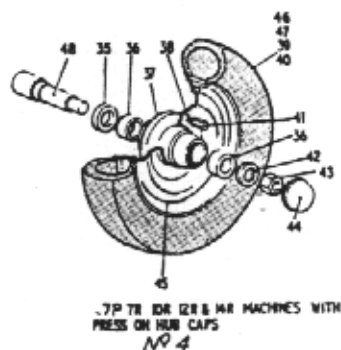
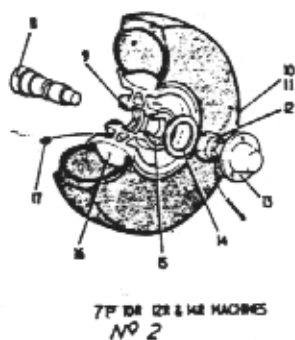
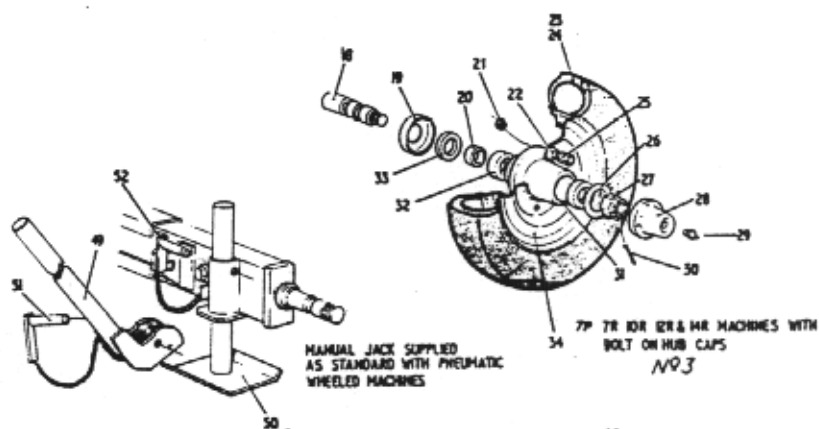

Ref N ^o	Description	Part N ^o	Qty
1	—	—	—
2	—	—	—
3	—	—	—
4	—	—	—
5	—	—	—
7	—	—	—
8	For 7P, 10R, 12R and 14R Machines fitted with 7.50 x 10.00 tyres (Illustration No. 2) Stub Axle complete with: Hex Hd Bolts Hex Nuts Spring Washers	555-1032 460-350832 330-350800 464-308000	4 4 4 4
9	Oil Seal	475-750109	4
10	Tyre	475-750101	4
11	Tube	475-750102	4
12	Axle Nut complete with Split Pin	475-750111	4
13	Hub Cap complete with Screws	475-750104	4
14	Fibre Washer	475-750110	4
15	Bearings	475-750107	8
16	Wheel Hub	475-750103	4
17	Grease Nipples	475-750106	4
18	For 7P, 7R, 10R, 12R and 14R Machines fitted with 6.50 x 16.00 tyres and bolt on hub caps (Illustration No. 3) Stub Axle complete with: Hex Hd Bolts Hex Nuts Spring Washers	555-1032 460-350832 330-350800 464-308000	4 4 4 4
19	Oil Guard	475-650009	4
20	Abutment Ring	475-650006	4
21	Locknut	331-209000	20

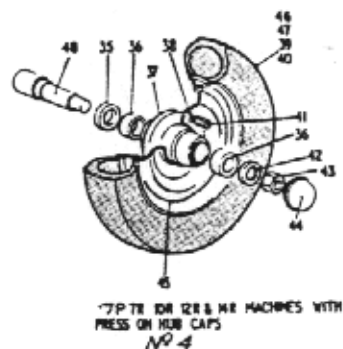
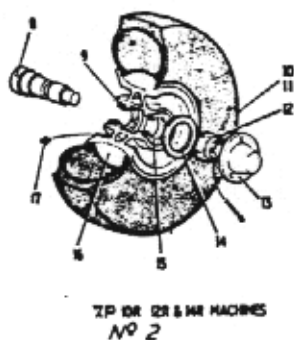
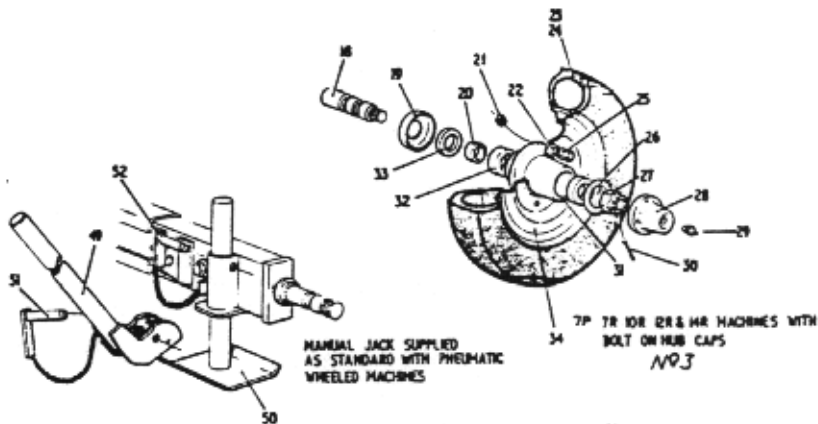

Ref No	Description	Part No	Qty
22	Stud	475-650004	20
23	Tyre	475-650001	4
24	Tube	475-650002	4
25	Nut	475-650008	20
26	Fibre Seal	475-650007	4
27	Axle Nut	475-650003	4
28	Hub Cap	475-650011	4
29	Greaser	475-650010	4
30	Split Pin	353-308200	4
31	Hub Shell	475-650005	4
32	Bearings	475-750107	8
33	Oil Seals	475-750109	4
34	Wheel Pressings	475-650013	4
	For 7P, 7R, 10R, 12R and 14R Machines fitted with 6.50 x 16.00 tyres or 6.00 x 16.00 RK3 tyres and press on hub caps (Illustration No. 4)		
35	Oil Seal	475-310001	4
36	Bearing	475-310002	8
37	Hub	475-310003	4
38	Wheel Stud	475-310004	5
39	Tyre (6.50 x 16.00)	475-650001	4
40	Tube (6.50 x 16.00)	475-650002	4
41	Wheel Nut	475-310005	5
42	Washer	475-310006	4
43	Axle Nut	475-310007	4
44	Grease Cap	475-310009	4
45	Wheel Pressing	475-650013	4
46	Tyre (6.00 x 16.00 RK3)	475-600017	4
47	Tube (6.00 x 16.00 RK3)	475-600018	4
48	Stub Axle complete with Hex Hd Bolts	555-5029 460-350832	4 4

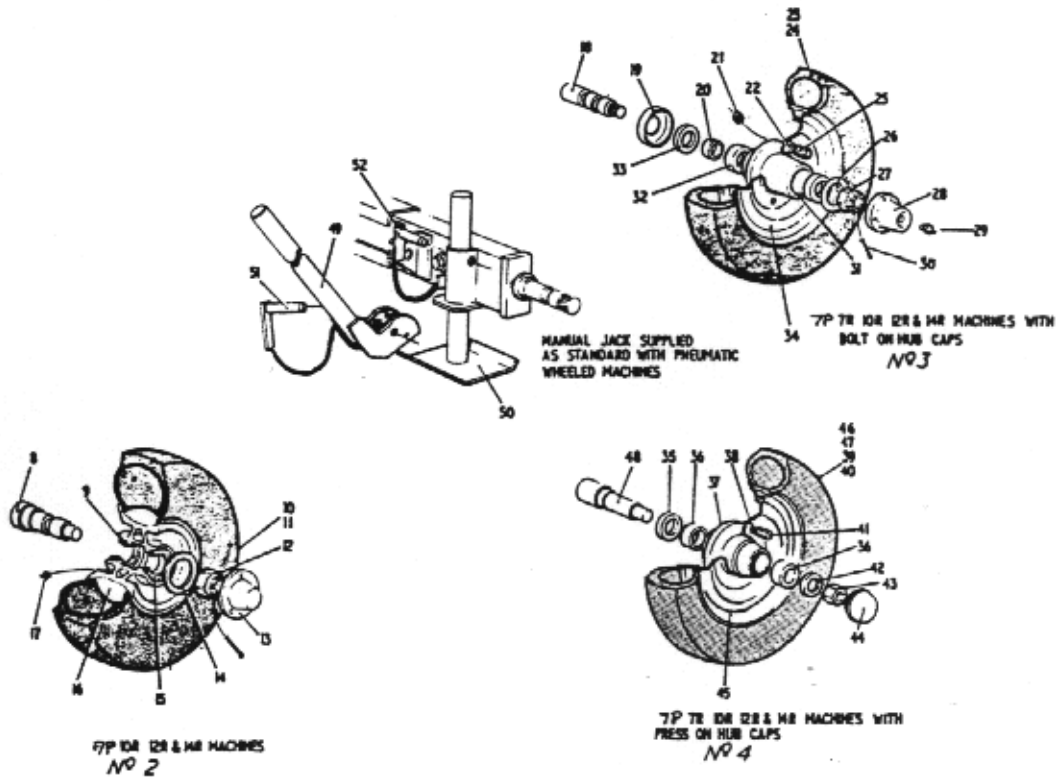

Ref N ^o	Description	Part N ^o	Qty
	Hex Nuts	330-350800	4
	Spring Washers	464-308000	4
	<p>Note: Wheel Assembly No. 4 can be fitted with 6.50 x 16.00 or 6.00 x 16.00 RK3 tyres and tubes (see items 39, 40, 46 and 47)</p>		
49	Manual Jack	555-1028	1
50	Jack Foot	555-1029	4
51	Jack Pivot Pin	555-1031	1
52	Jack Pin	555-1030	1 set

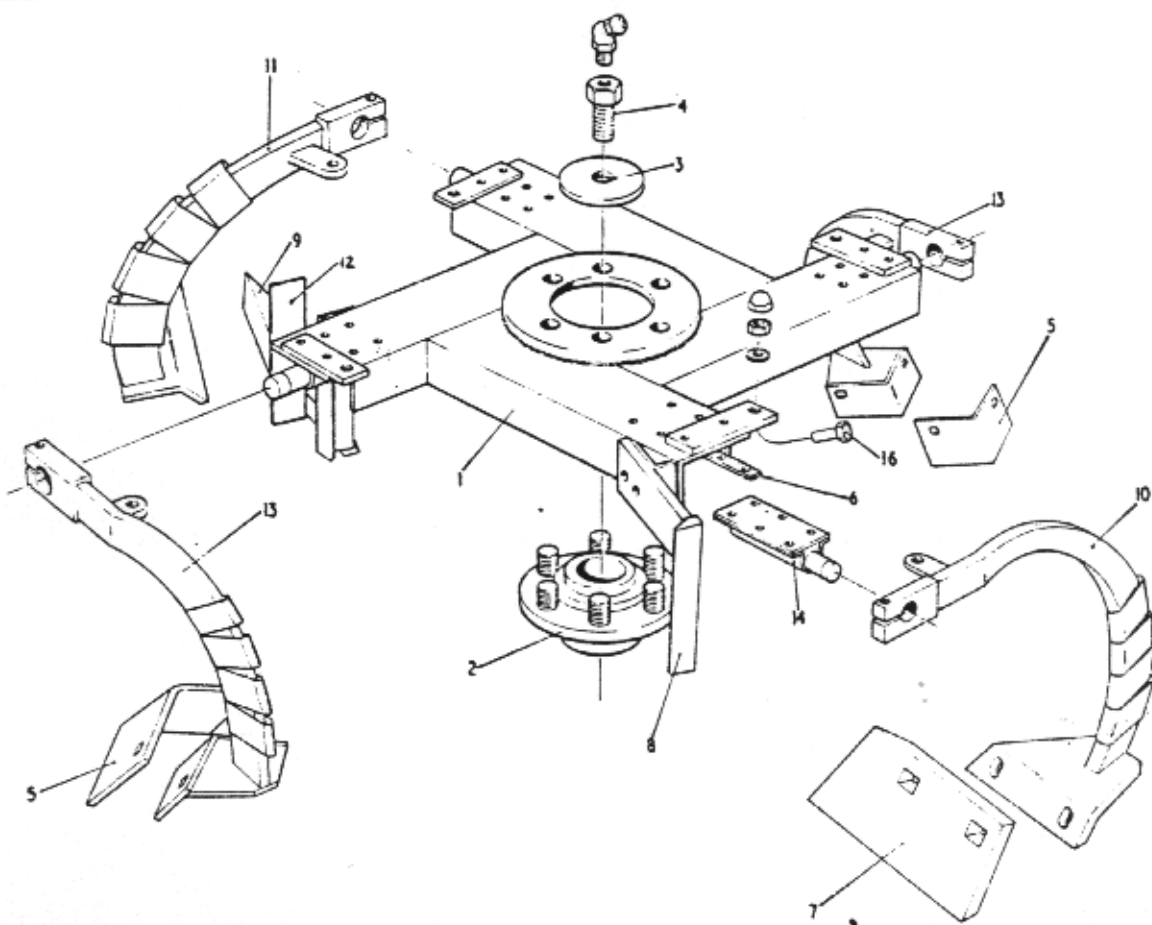

Ref N ^o	Description	Part N ^o	Qty
1	Flexitor Rotor	555-1968	1
2	Rotor Carrier complete with Hex Nuts Spring Washers	512-1064 331-851000 464-310000	1 6 6
3	Reduction Shaft Retaining Collar	512-1051	1
4	Setscrew complete with Grease Nipple	555-1598 333-773000	1 1
5	Plough Blade complete with Special Bolts Binx Nuts Plain Washers	512-1392 -- 514-1624 330-310800 463-308000	2 4 4 4
6	Flexitor Packer	555-1965	8
7	Inner Paddle Blade complete with Special Bolts Binx Nuts Plain Washers	512-1393 - 514-1624 330-310800 463-308000	1 2 2 2
8	Outer Scraper Blade complete with Hex Hd Bolts Hex Nuts Plain Washers Spring Washers	555-1967 - 460-508018 331-850800 463-308000 464-308000	1 2 2 2 2
9	Outer Paddle Blade complete with Special Bolts Binx Nuts Plain Washers	512-1394 - 514-1624 330-310800 463-308000	1 2 2 2
10	Inner Mixing Blade Arm complete with Hex Hd Bolt Hex Nut Spring Washer	512-1067 - 460-508026 331-850800 464-308000	1 1 1 1

69805K

192805

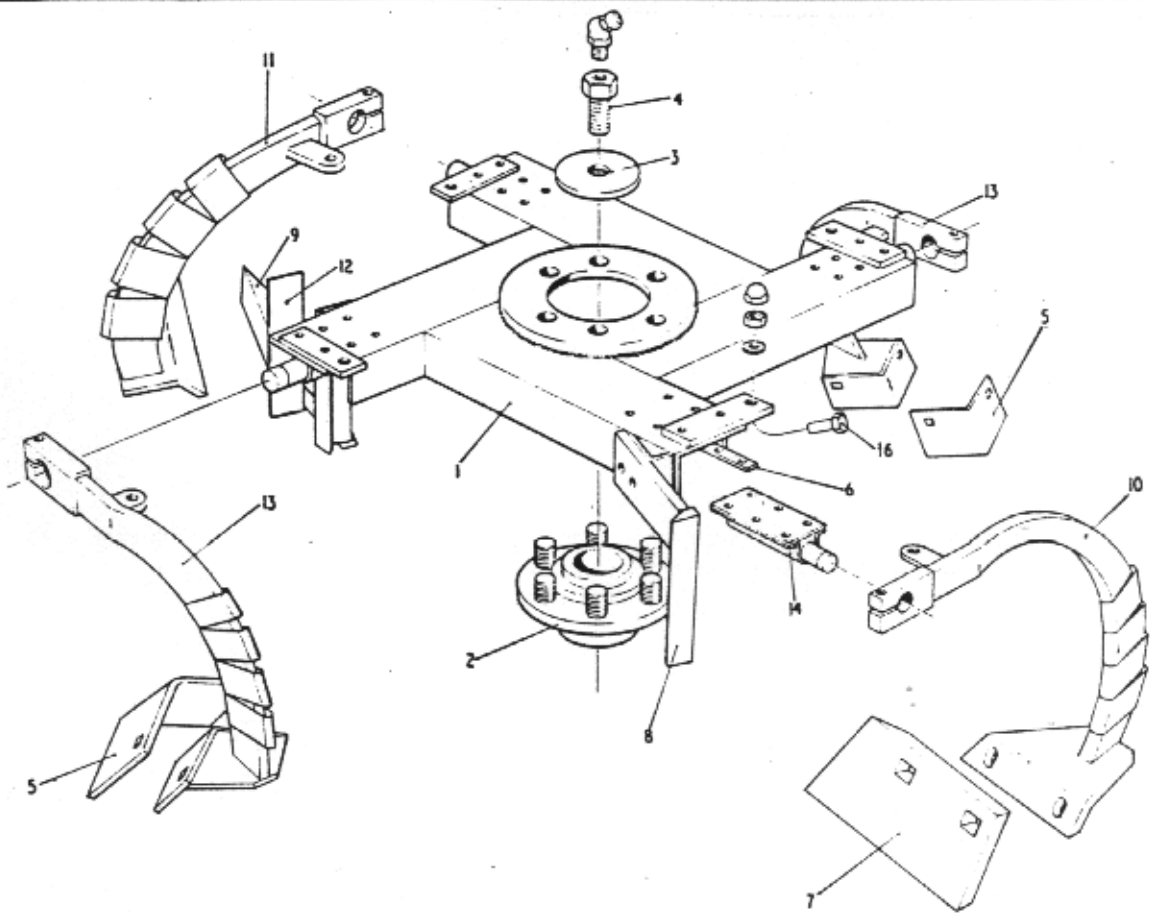

Ref N ^o	Description	Part N ^o	Qty
11	Outer Mixing Blade Arm complete with	512-1068 -	1
	Hex Hd Bolt	460-508026	1
	Hex Nut	331-850800	1
	Spring Washer	464-308000	1
		555-1578 -	1
12	Inner Scraper Blade complete with	460-508014	2
	Hex Hd Bolts	330-350800	2
	Hex Nuts	464-308000	2
	Spring Washers	463-308000	2
	Plain Washers	512-1065 -	2
13	Plough Blade Arm complete with q	460-508026	2
	Hex Hd Bolts	331-850800	2
	Hex Nuts	464-308000	2
	Spring Washers	447-102000	4
		460-506010	24
14	Flexitor complete with	331-850600	24
	Hex Hd Bolts	464-306000	24
	Hex Nuts	512-1040 -	16
	Spring Washers	460-508030	4
15	Gaiters for Paddle Arms	331-850800	4
	Hex Hd Bolt complete with	332-726000	4
	Hex Nut	463-308000	4
	Domed Nut		
	Plain Washer		

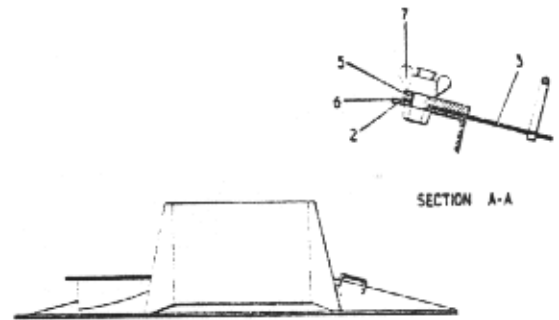
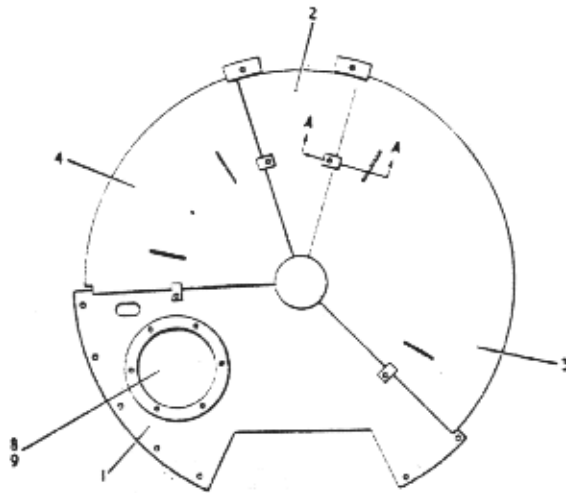

Ref N ^o	Description	Part N ^o	Qty	
1	Pan Cover - Feed Sector complete with	555-1539	1	
		Hex Hd Bolt	460-50808	7
		Hex Nut	331-8508	7
		Spring Washer	464-308	7
			555-1542	1
2	Pan Cover - Small Fixed Sector complete with	Hex Hd Bolt	460-50808	2
		Hex Nut	331-8508	2
		Spring Washer	464-308	2
			555-1540	1
3	Pan Cover - Large Loose	555-1541	1	
4	Pan Cover - Small Loose	555-1544	4	
5	Pan Cover Clip	463-308	4	
6	Bright Washers	335-158	4	
7	Wing Nut	555-1543	1	
8	Cover Plate complete with	Hex Hd Bolt	460-50808	6
		Hex Nuts	331-8506	6
		Spring Washers	464-306	6
			555-1545	1
9	Gasket			

PAN COVERS

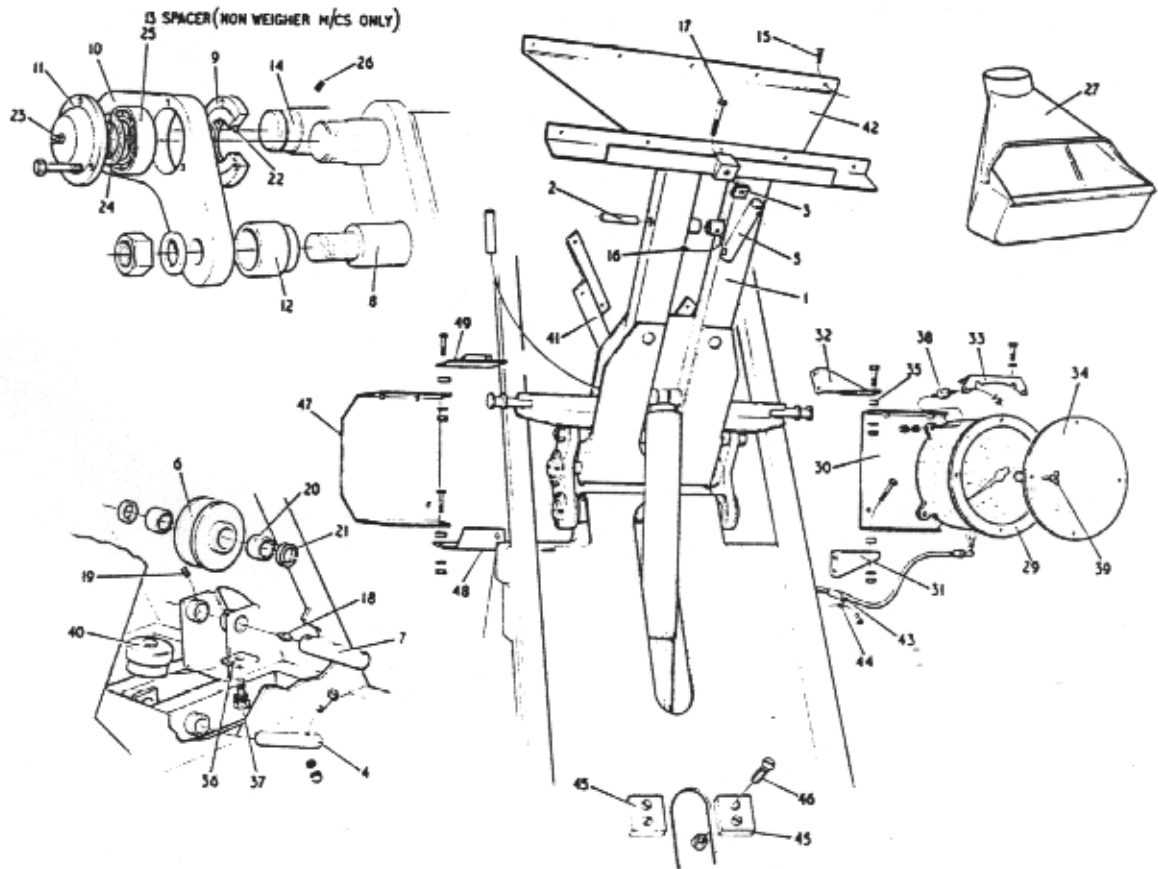

Ref No	Description	Part No	Qty
1	Hopper Cradle (without Dragline)	555-1079	+ *
	Hopper Cradle (with Dragline)	555-1206	1 1
2	Hopper Cradle Pin	555-1093	1 -
3	Loadcell Striker Packer	555-1092	1Set -
4	Hopper Ram Pin complete with	555-1085	2 2
	Hex Hd Bolts	460-350618	2 2
	Hex Nuts	330-3506	2 2
	Spring Washers	464-306	2 2
5	Loadcell Striker	555-1091	1 -
6	Loadcell Striker Guide	555-1089	1 -
7	Pin for Loadcell Striker Guide	555-1090	1 -
8	Link Shaft complete with	555-1087	1 1
	Hex Nuts	330-3520	2 2
	Plain Washers	463-320	2 2
9	Seal Housing	555-1086	4 4
10	Link Arm	555-1088	1pr 1pr
11	Bearing Cap complete with	555-1219	4 4
	Hex Hd Bolts	460-50516	12 12
	Spring Washers	464-305	12 12
12	Sleeve	555-1095	- 2
13	Spacer	555-1094	- 2
14	Shaft	555-1080	1 1
15	Csk Hd Screw complete with	400-151014	9 9
	Hex Nut	330-35010	9 9
	Lock Nut	330-5510	9 9
16	Socket Setscrew with Cone Point	404-910510	1 -
17	Hex Hd Setscrew complete with	418-250826	1 -
	Spring Washers	464-308	1 -
18	StraightGrease Nipple	333-1061	1 -
19	Socket Setscrew Flat Point	404-90608	1 -
20	Needle Roller Bearing	113-149	2 -

CRADLE HOPPER LOADCELL & GAUGE

*Weigher
 *Non
 Weigher

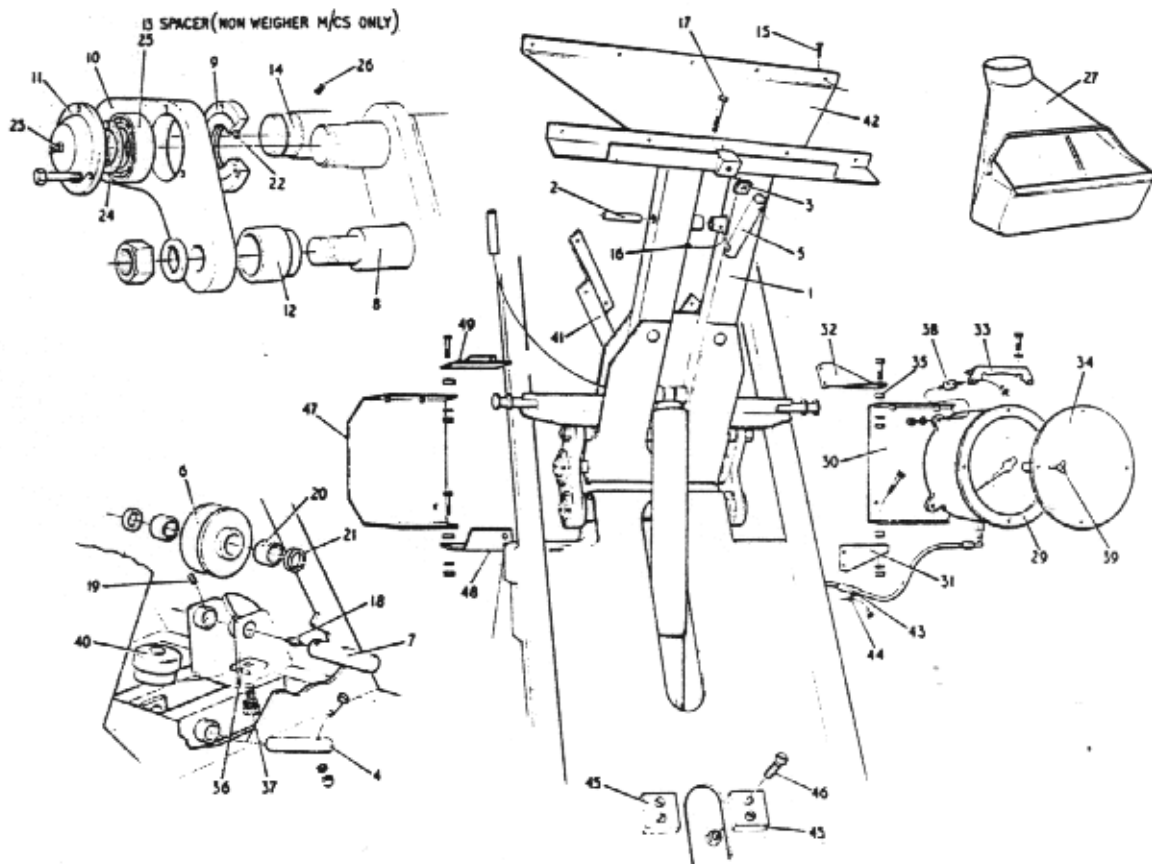

Ref No	Description	Part No	Qty
			+ *
21	Seal	417-780	2 -
22	Nu-Lip Rings	391-802	4 4
23	Grease Nipple 45°	333-8011	4 4
24	External Circlip	142-318	4 2
25	Needle Roller Bearing	103-951	4 2
26	Socket Setscrew Cone P.T.	404-910610	2 2
27	Hopper	555-1044	1 1
28	Chain for Hopper (Not Illustrated)	50-29285	1 1
29	Weigh Gauge	267-204	1 -
30	Weigh Dial Mounting Plate complete with	555-1246	1 -
	Hex Hd Bolts	460-50606	2 -
	Spring Washers	464-306	2 -
31	Weigh Dial support (Lower) complete with	555-1247	1 -
	Hex Hd Bolt	460-50812	1 -
	Hex Nut	330-3508	1 -
	Spring Washer	464-308	1 -
	Hex Hd Bolt	460-50E08	2 -
	Hex Nut	330-3506	2 -
	Spring Washer	464-306	2 -
32	Weigh Dial support (Upper) complete with	555-1248	1 -
	Hex Hd Bolt	460-50812	1 -
	Hex Nut	330-3508	1 -
	Spring Washer	464-308	1 -
	Hex Hd Setscrews	418-250606	2 -
	Hex Nuts	330-3506	2 -
	Spring Washers	464-306	2 -
33	Weigh Dial Mounting Plate (Upper)	555-1249	1 -

†Weigher
*Non
Weigher

CRADLE HOPPER LOADCELL & GAUGE

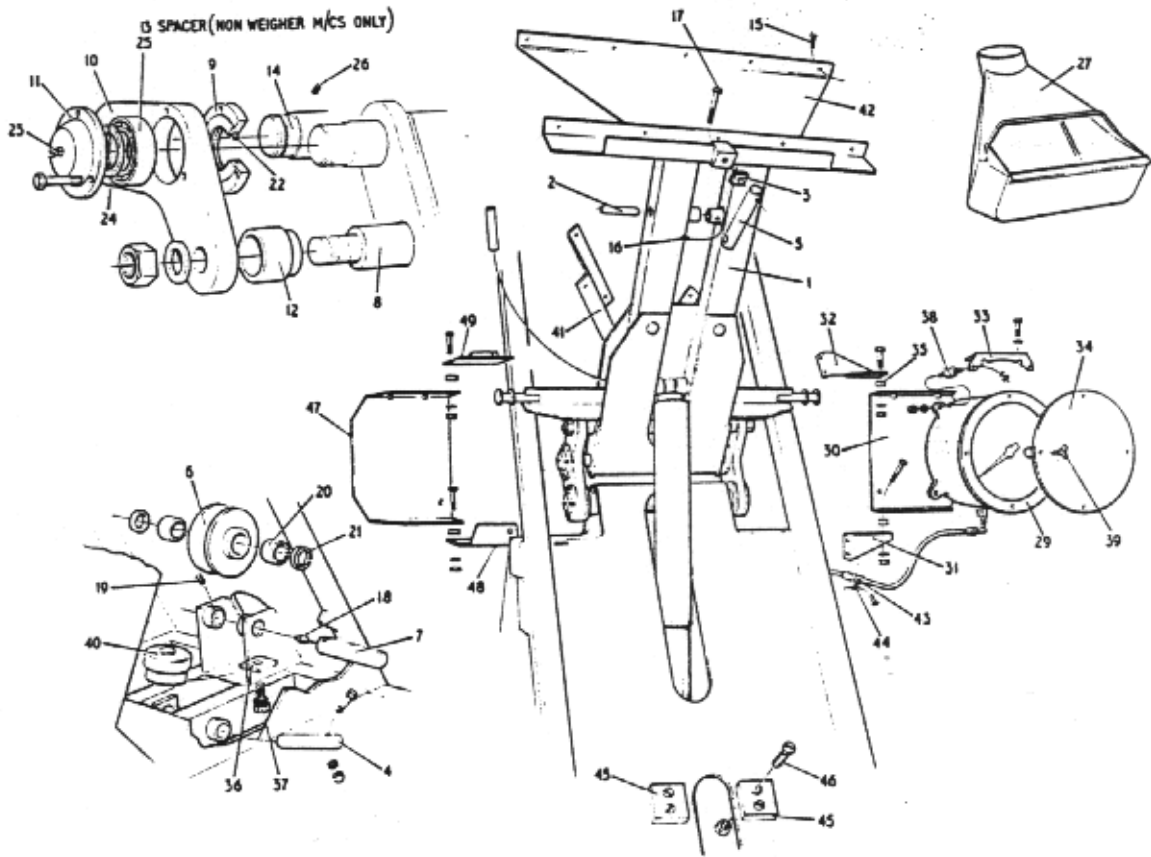

Ref N ^o	Description	Part N ^o	Qty
			+ *
34	Dial Cover	555-1250	1 -
35	Spacer	555-1251	2 -
36	Loadcell Packer	512-1183	1 Set -
37	Hex Hd Setscrew complete with	418-350810	1 -
	Spring Washer	464-308	1 -
38	Flexible Mountings complete with	105-343	4 -
	Hex Nuts	330-505	8 -
	Spring Washers	464-305	8 -
39	Thumb Screw	407-310512	4 -
40	Loadcell & Gauge complete	555-1243	1 -
41	Packing Bracket complete with	555-1098	2 2
	Hex Hd Bolt	460-351010	4 4
	Binx Nut	330-3610	4 4
	Plain Washers	463-310	4 4
42	Hopper Packer complete with	555-1099	1 1
	Hex Hd Bolt	460-351010	3 3
	Binx Nut	330-3610	3 3
	Plain Washers	463-310	3 3
43	Hose Guard	555-1701	1 -
44	Brass Cable Clip complete with	143-246	2 -
	Hex Hd Bolt	418-9025	2 -
	Hex Nut	331-802	2 -
	Spring Washer	463-102	2 -
45	Cradle Stop	555-1096	- 2
46	Csk Screws complete with	400-150812	- 4
	Binx Nut	335-7608	- 4

†Weigher
*Non Weigher

CRADLE HOPPER LOADCELL & GAUGE

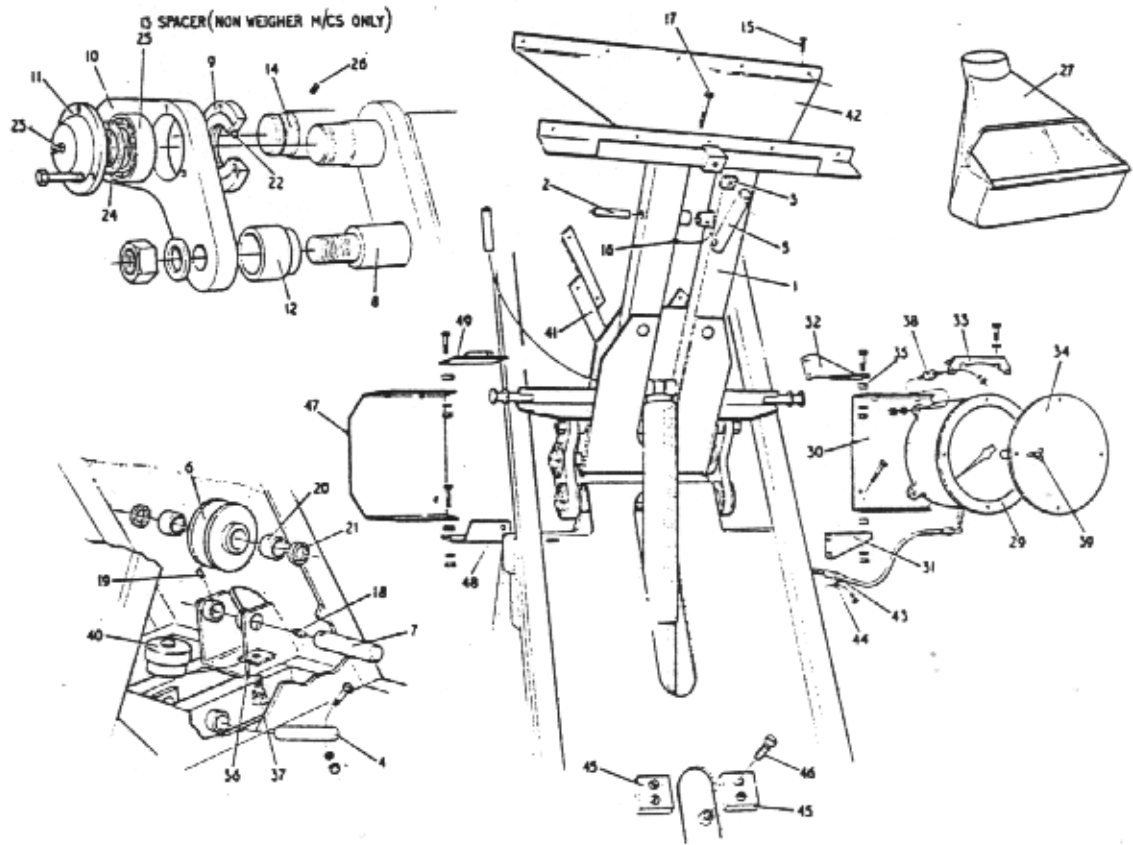

Ref N ^o	Description	Part N ^o	Qty
47	Weigh Dial Mounting Plate complete with Hex Hd Bolts Spring Washers	555-1927	1
		460-350606	2
		464-306000	2
48	Weigh Dial Support (Lower) complete with Hex Hd Bolts Hex Nuts Spring Washers	555-1928	1
		460-350830	2
		330-350800	3
		464-308000	3
		460-350812	1
49	Weigh Dial Support (Upper) complete with Hex Hd Bolt Hex Nut Spring Washer Hex Hd Bolt Hex Nut Spring Washer	555-1929	1
		460-350626	1
		330-350600	1
		464-306000	1
		460-350812	1
		330-350800	1
		464-308000	1

CRADLE HOPPER LOADCELL & GAUGE

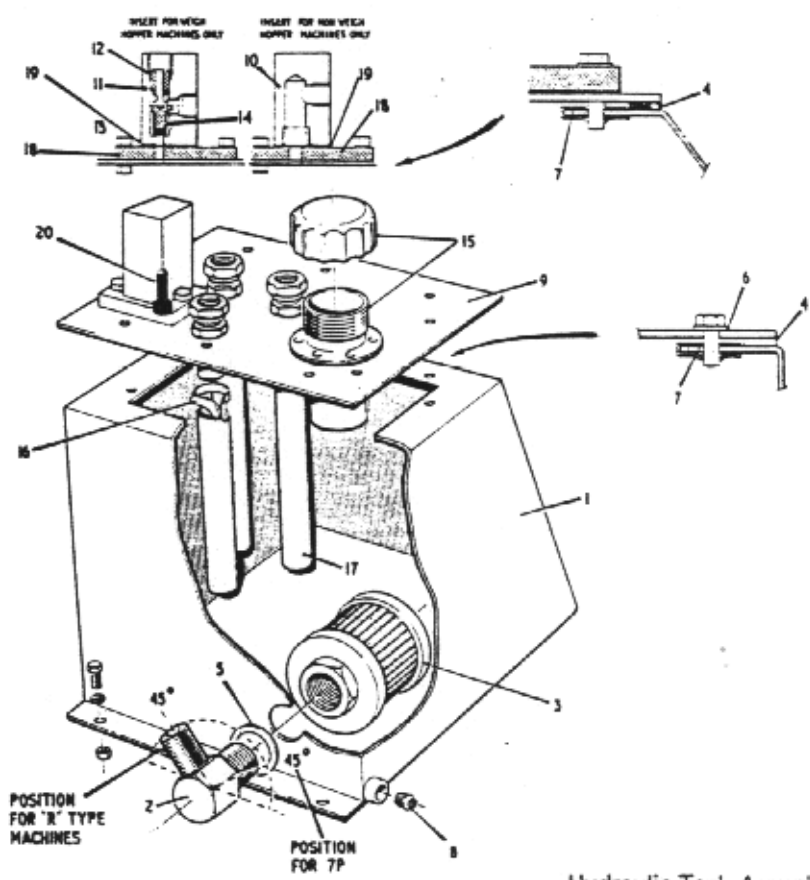

Hydraulic Tank Assembly 555-1356

Ref N ^o	Description	Part N ^o	Qty
1	Hydraulic Tank complete with Hex Hd Bolt Hex Nut Spring Washers	555-1359 460-50608 331-8506 464-306	1 3 3 3
2	Strainer Connection	555-1361	1
3	Single Unit Suction Filter	220-514	1
4	Self Adhesive Gasket	254-916	1 Length
5	Bonded Seal	417-808	1
6	Selon Washers	464-804	11
7	Spire Captive Nut	332-719	10
8	Taper Plug	360-208	1
9	Cover for Hydraulic Tank complete with Hex Hd Setscrews	555-1360 418-350405	1 9
10	Connecting Block (Non Weigher M/Cs) complete with	555-1373	1
11	Bleed Valve Block (Weigher M/Cs) complete with	555-1374	1
12	Bleed Valve Plunger	50-31395	1
13	Bleed Valve Joint	555-1375	1
14	Compression Spring	420-428	1
15	Filler Breather with Self Tap Screws	220-246	1
16	Hose Clamp	143-108	3
17	Clear P.V.C. Tube	260-81208	3
18	Adaptor Plate complete with Hex Hd Bolt Hex Hd Setscrew	555-1869 460-50411 418-350408	1 1 1
19	Adaptor Plate Gasket	555-1870	1
20	Skt Hd. Capscrews	404-70410	2

HYDRAULIC TANK

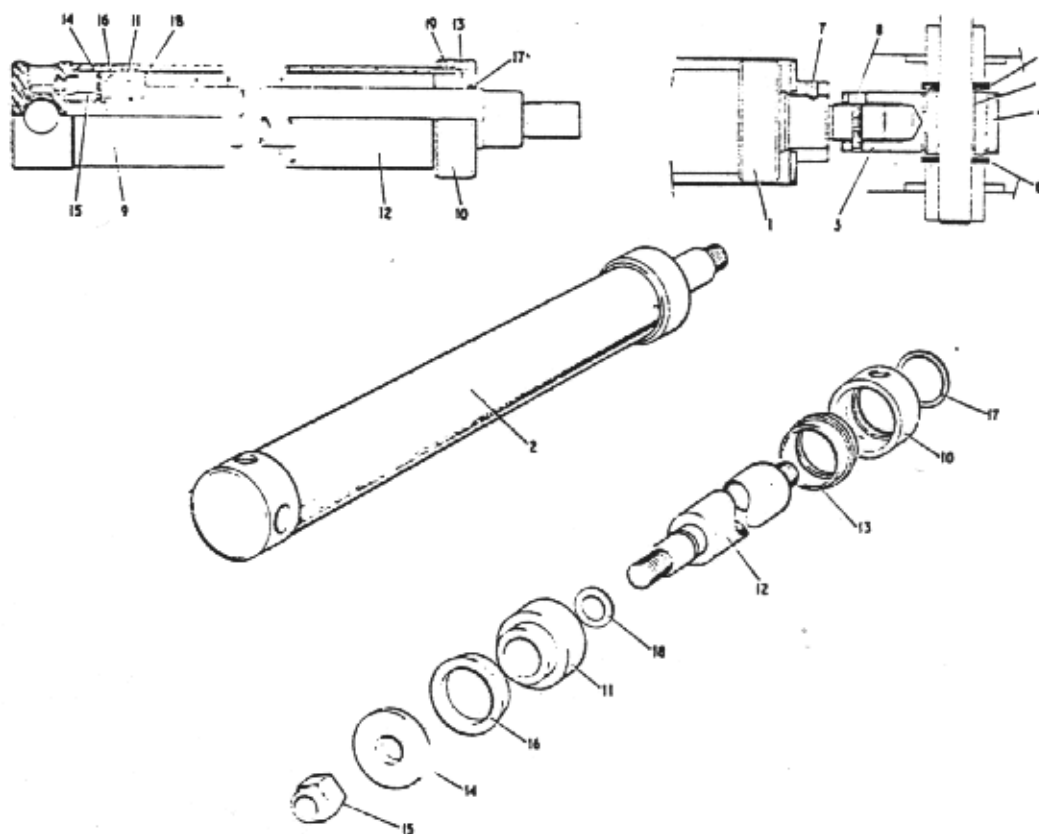

Ref N ^o	Description	Part N ^o	Qty
1	Ram Shroud	555-1367	1
2	Hopper Ram	555-1376	1
3	End Piece for Ram	555-1368	1
4	Insert for Ram End	555-1365	1
5	Bush	112-801100	2
6	Bright Plain Washers	555-1679	2
7	Skt. Screw (Half Dog PT.)	404-930606	1
8	Skt. Hd. Capscrews	404-706240	2
9	Tube Assy	L1753 272-127100	1
10	Locking Ring	L1752 272-127200	1
11	Piston Head	L1748 272-127300	1
12	Piston Rod	L1747 272-127400	1
13	Insert	L1751 272-127500	1
14	Back-up Plage	L1749 272-127600	1
15	Locknut	L222 272-127700	1
16	Piston Seal	L1754 272-127800	1
17	Wiper Ring	L1755 272-127900	1
18	Piston Head 'O' Ring	L220 272-127010	1
19	Grub Screw	L1582 272-127011	1

Hopper Ram - Up to Ram No. 8200

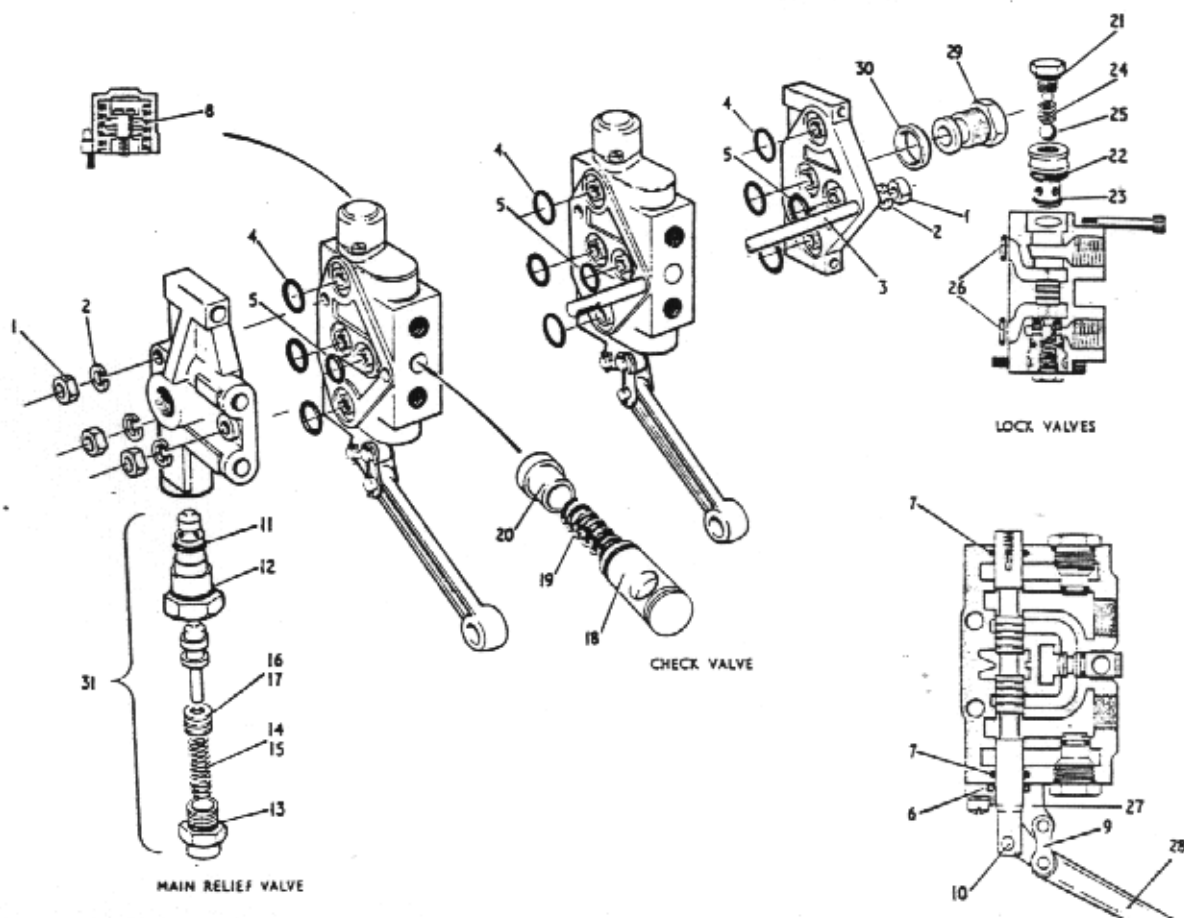

Ref No	Description	Part No	Qty	
* 1	Hex Nut	102/5/00152	451-431111	6
* 2	Spring Washer	102/5/00275	451-431200	6
* 3	Stud Range	102/3/00091-99	451-431300	3
* 4	'O' Ring	102/5/00071	451-431400	9
* 5	'O' Ring	102/5/00072	451-431500	3
* 6	Wiper Seal	102/5/00231	451-431600	1
* 7	'O' Ring	HE/4600/2	451-431700	2
* 8	Spring	102/5/00038	451-431800	1
* 9	Link	102/5/00013	451-431900	1
* 10	Pin	102/5/00045	451-431100	1
* 11	'O' Ring	102/5/000427	451-431110	1
* 12	'O' Ring	102/5/00086	451-431120	1
* 13	'O' Ring	102/5/00077	451-431130	1
* 14	Spring (500-1500 P.S.I.)	102/5/00145	451-431140	1
* 15	Spring (1500-3000 P.S.I.)	102/5/00056	451-431150	1
* 16	Shim 003"	102/5/00059	451-431160	As Reqd.
* 17	Shim 020"	102/5/00122	451-431170	As Reqd.
* 18	'O' Ring	HE/3500/8	451-431180	1
* 19	Spring	102/5/00043	451-431190	1
* 20	Poppet	102/5/00042	451-431200	1
* 21	'O' Ring	HE/3500/8	451-431210	2
* 22	'O' Ring	HE/1500/11	451-431220	2
* 23	'O' Ring	102/5/00060	451-431230	2
* 24	Spring	102/5/00106	451-431240	2
* 25	Ball	102/5/00090	451-431250	2
* 26	'O' Ring	102/5/00072	451-431260	2
* 27	Handle Bracket	102/5/00004	451-431270	1
* 28	Handle	102/3/00015	451-431280	1
* 29	Adaptor	102/3/00133	451-431290	1
* 30	Bonded Seal	102/5/00151	451-431300	1
* 31	Main Relief Valve complete	102/5/3079	451-431310	1

CONTROL VALVE

*WHEN ORDERING THESE SPARES PLEASE QUOTE DESCRIPTION & CODE PRECEDING ALSO

When Ordering Always Quote — Machine No, Part No, Description & Quantity

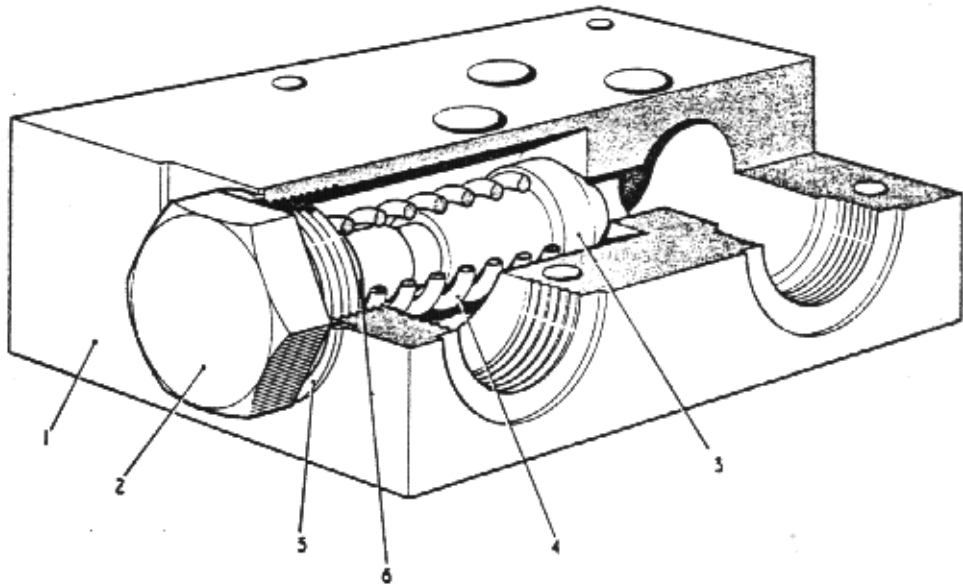

• Relief Valve to "Blow Off" at 1000/1200 P.S.I.

Dragline Control Block Assembly 555-1378

Ref N ^o	Description	Part N ^o	Qty
1	Dragline Control Block	555-1379	1
2	Valve Guide	555-1382	1
3	Relief Valve	555-1383	1
4	Compression Spring	555-1384	1
5	Bonded Seal	417-804	1
6	Plain Washers	463-305	As Req.

DRAGLINE CONTROL BLOCK

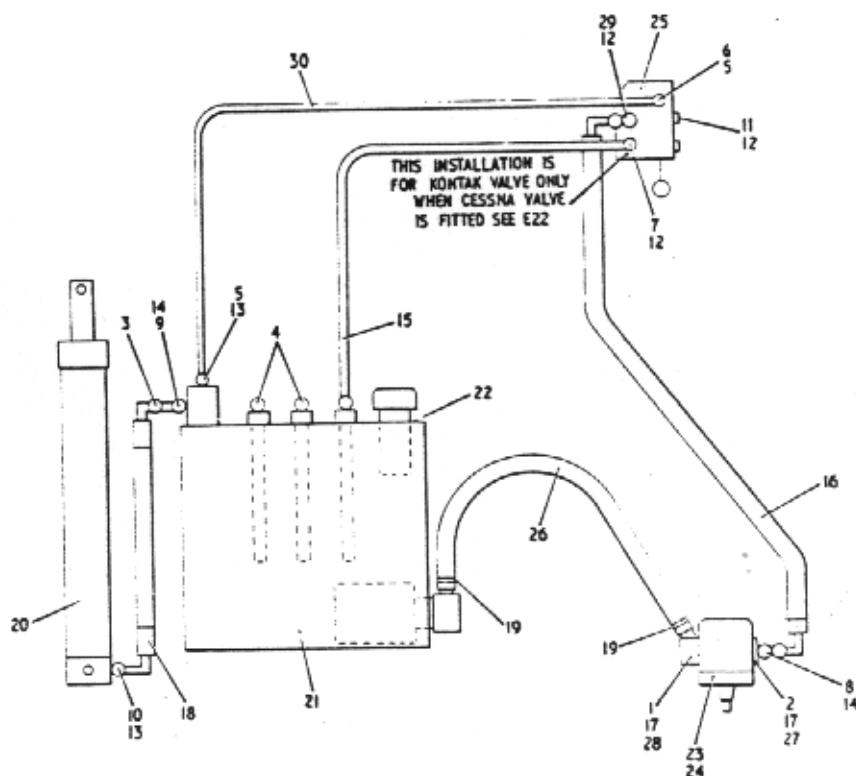

Ref N ^o	Description	Part N ^o	Qty
1	Pump Inlet Connector	555-1369	1
2	Pump Outlet Connector	555-1364	1
3	Connection for Flexible Pipe	513-1195	1
4	Blank Bars	555-1368	2
5 ●	Male Stud Coupling	446-349000	2
6	Bonded Seal	417-804000	1
* 7 ●	Male Stud Coupling	446-335000	1
8	Male Stud Adaptor	446-611000	1
9 □	Standpipe Adaptor	446-403000	1
10 △	Male Coned Adaptor	446-614000	1
* 11 ○	Brass Collared Plug	360-106000	1
* 12 *	Bonded Seals	417-806000	3
13 *	Bonded Seals	417-804000	2
14 *	Bonded Seals	417-803000	2
15	Tank to Control Valve Pipe	555-1696	1
16	Pump to Control Valve Hose	555-1895	1
17 ■	'O' Ring	391-832000	2
18	Hopper Ram Hose	555-2043	1
19	Hose Clamp	143-152000	2
20	Hopper Ram Assembly Complete with Shroud (See E6)	555-1358	1
21	Hydraulic Tank Assembly (See E5)	555-1356	1
22	Hydraulic Tank Cover Assembly (See E5)	555-1357	1
23	Pump (Diesel M/C's Only) Complete with Hex Hd Screws Spring Washers	365-823000 418-350410 464-304000	1 4 4
24	Pump (Electric M/C's Only) Complete with Hex Hd Screws Spring Washers	365-322000 418-350410 464-304000	1 4 4
* 25	Kontak Control Valve Complete with (See E7) Hex Hd Screws Hex Nuts Spring Washers	451-431000 418-250520 330-350500 464-305000	1 3 3 3

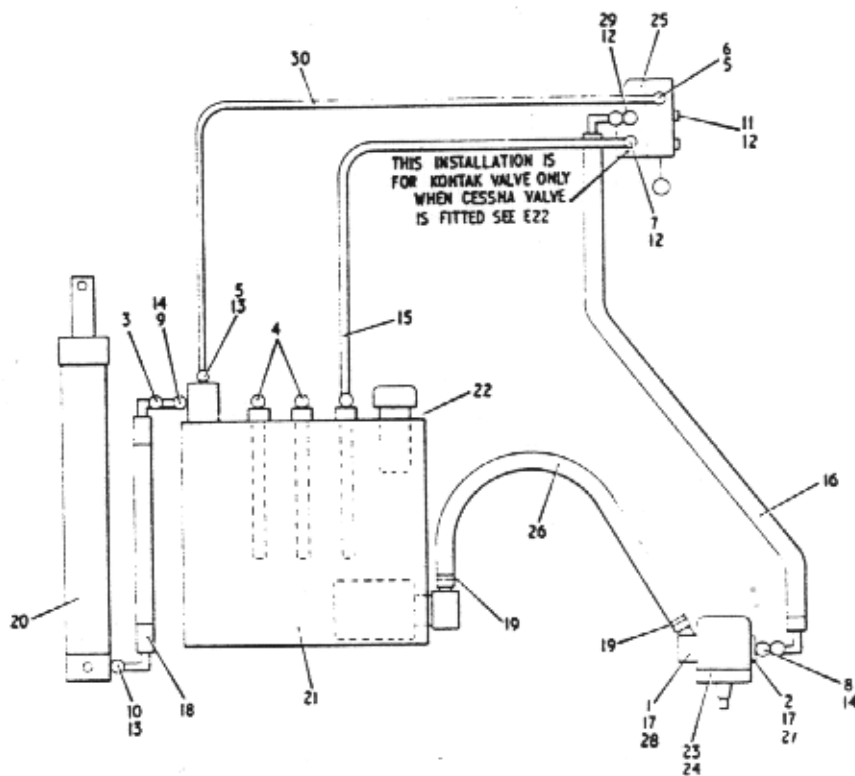

Ref N ^o	Description	Part N ^o	Qty
26	Oil Resistant Hose (Blue)	260-908010	1
27	Skt Hd Capscrew	404-750516	4
28	—	—	—
*29	Adaptor Male Reducer	013-410000	1
30	Bleed Valve to Control Valve Pipe	555-1690	1
<p>Items marked thus * for use with 'Kontak' Control Valve only</p>			

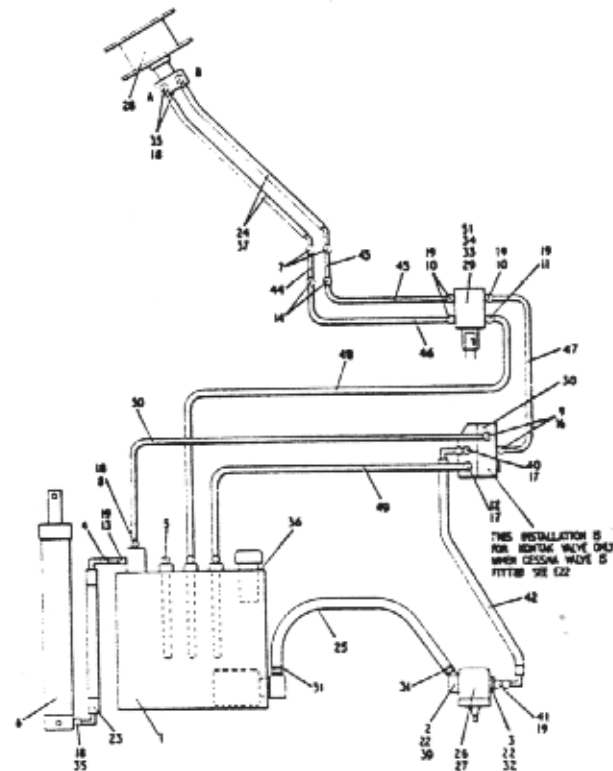

Ref No	Description	Part No	Qty
1	Hydraulic Tank (See E5)	555-1356	1
2	Pump Inlet Connector	555-1369	1
3	Pump Outlet Connector	555-1364	1
4	Connection for Flexible Pipe	513-1195	1
5	Blanking Bar	555-1368	1
6	Hopper Ram Assembly Complete with Shroud (See E6)	555-1358	1
7	Pipe Header	555-1380	1
8 ●	Male Stud Coupling	446-349000	1
9 ●	Male Stud Couplings	446-349000	2
10 ●	Male Stud Couplings	446-628000	3
11 ●	Male Stud Coupling	446-631000	1
12 ●	Male Stud Coupling	446-335000	1
13 □	Standpipe Adaptor	446-403000	1
14	Bulkhead Fittings	466-488000	2
15	—	—	—
16 *	Bonded Seals	417-804000	2
17 *	Bonded Seals	417-806000	2
18 *	Bonded Seals	417-804000	4
19 *	Bonded Seals	417-803000	6
20	—	—	—
21	—	—	—
22 ■	'O' Rings	391-832000	2
23	Hopper Ram Hose	555-2043	1
24	Dragline Winch Hose	555-2044	2
25	Oil Resistant Hose (Blue)	260-908010	1
26	Pump (Diesel M/C's Only) Complete with Hex Hd Screws	365-823000	1
	Spring Washers	418-350410	4
	Spring Washers	464-304000	4
27	Pump (Electric M/C's Only) Complete with Hex Hd Screws	365-822000	1
	Spring Washers	418-350410	4
	Spring Washers	464-304000	4

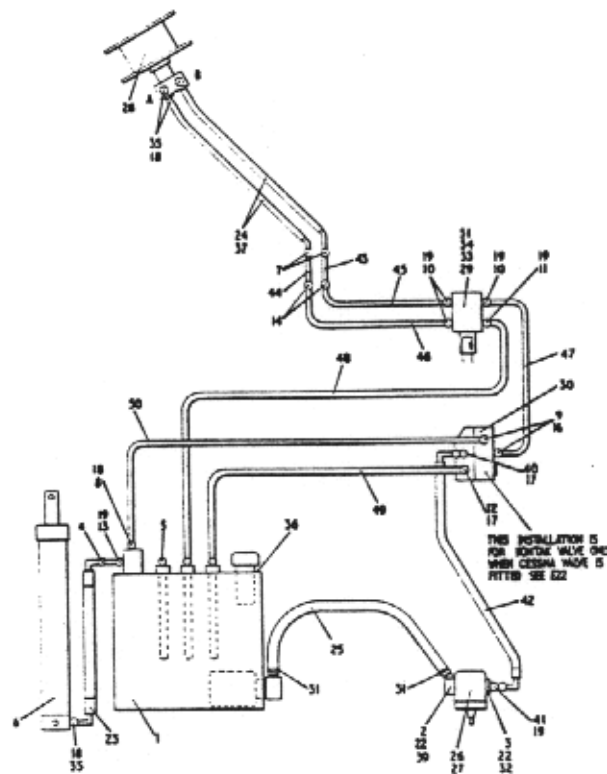

Ref N ^o	Description	Part N ^o	Qty
28	Hydraulic Winch Mk II (See H3)	555-1226	1
	Hydraulic Winch Mk III (See H4)	555-1917	1
29	Valve Complete with	450-696000	1
	Hex Hd Screws	418-350405	4
	Spring Washers	464-304000	4
30	Control Valve Complete with (See E7)	451-431000	1
	Hex Hd Screws	418-250620	3
	Hex Nuts	330-350600	3
	Spring Washers	464-306000	3
31	Hose Clamps	143-159000	2
32 Δ	Skt Hd Capscrews	404-750516	4
33 Δ	Skt Hd Capscrews	404-750444	4
34	Dragline Control Block Assembly (See E8)	555-1378	1
35 ▲	Male Coned Adaptors	466-614000	3
36	Hydraulic Tank Cover Assembly (See E5)	555-1357	1
37	P.V.C. Covered Strap and Buckles	124-108900	2
38 Δ	Skt Hd Capscrews - Vickers Valve Only	404-750240	4
39	-	-	-
*40	Adaptor Male Reducer	013-410000	1
41	Male Stud Adaptor	446-611000	1
42	Pump to Control Valve Hose	555-1895	1
43	Bulkhead to Pipe Header (Supply) Pipe	555-1694	1
44	Bulkhead to Pipe Header (Return) Pipe	555-1695	1
45	Solenoid Valve to Bulkhead (Supply) Pipe	555-1692	1
46	Bulkhead to Solenoid Valve (Return) Pipe	555-1693	1
47	Control Valve to Solenoid Valve Pipe	555-1691	1
48	Tank to Solenoid Valve Pipe	555-1697	1
49	Tank to Control Valve Pipe	555-1696	1
50	Bleed Valve to Control Valve Pipe	555-1690	1
51	Valve Cover Plate	555-1946	1

Items marked thus * for use with 'Kontak' Control Valve only

211/58000

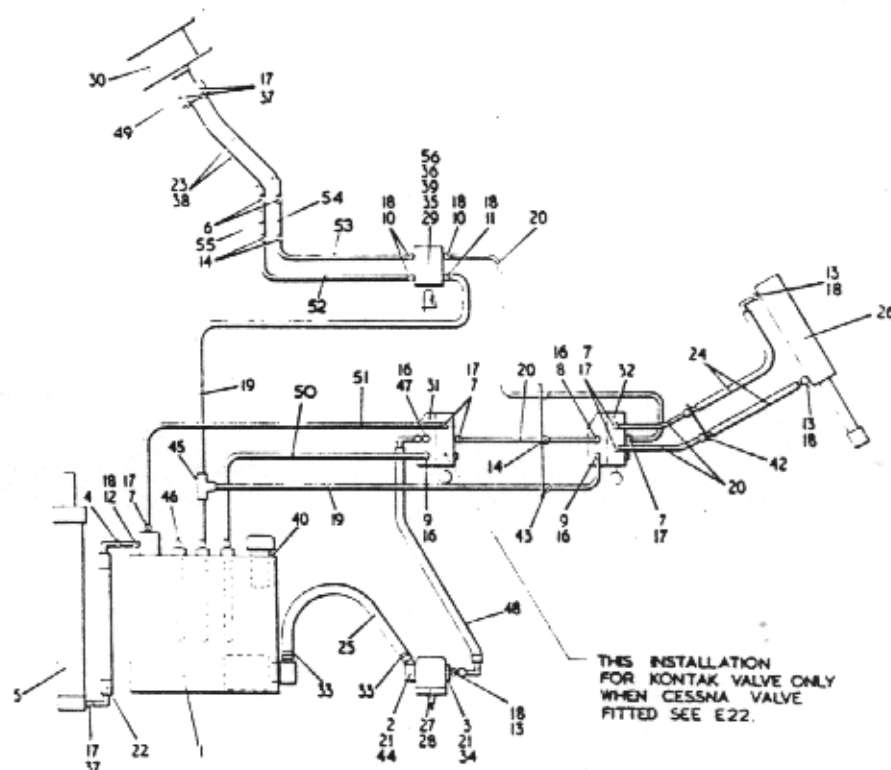

Ref No	Description	Part No	Qty
1	Hydraulic Tank Assembly (See E5)	555-1356	1
2	Pump Inlet Connector	555-1370	1
3	Pump Outlet Connector	555-1364	1
4	Connection for Flexible Pipe	513-1195	1
5	Hopper Ram Assembly Complete with Shroud (See E6)	555-1358	1
6	Pipe Header	555-1380	1
7 ●	Male Stud Couplings	446-349000	6
8 ●	Male Stud Coupling	446-612000	1
9 ●	Male Stud Couplings	446-335000	2
10 ●	Male Stud Couplings	446-628000	3
11 ●	Male Stud Coupling	446-631000	1
12 □	Standpipe Adaptor	446-403000	1
13 ▲	Male Coned Adaptor	446-611000	3
14	Bulkhead Fittings	221-303000	3
15	—	—	—
16 *	Bonded Seals	417-806000	4
17 *	Bonded Seals	417-804000	9
18 *	Bonded Seals	417-803000	8
19	Bright Steel Tube — Length to suit	—	1
20	Bright Steel Tube — Length to suit	—	1
21 ■	'O' Rings	391-832000	2
22	Hopper Ram Hose	555-2043	1
23	Dragline Winch Hose	555-2044	2
24	Single Wire Hose Female Straight Female 90°	260-909000	2
25	Oil Resistant Hose (Blue)	260-908010	1
26	Double Acting Ram (See E18)	272-126000	1
27	Pump (Diesel Machines Only) Complete with Hex Hd Bolts	361-132000	1
	Binx Nuts	460-350410	4
	Binx Nuts	330-360400	4
28	Pump (Electric Machines Only) Complete with Hex Hd Bolts	361-133000	1
	Binx Nuts	460-350410	4
	Binx Nuts	330-360400	4

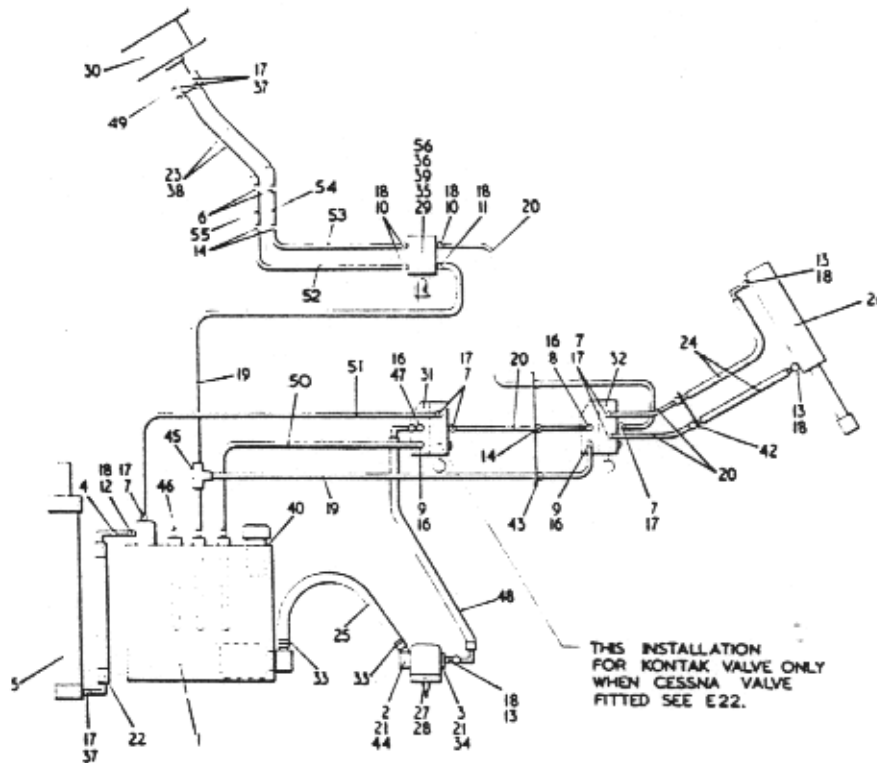

Ref N ^o	Description	Part N ^o	Qty
29	Valve Complete with Hex Hd Screws Spring Washers	450-661000 418-350405 464-304000	1 4 4
30	Hydraulic Winch Mk II (See H3) Hydraulic Winch Mk III (See H4)	555-1226 555-1917	1 1
31	'Kontak' Control Valve Complete with Hex Hd Screws Hex Nuts Spring Washers	451-431000 418-250620 330-350600 464-306000	1 3 3 3
32	Control Valve complete with Hex Hd Bolts Hex Nuts Spring Washers	451-435000 418-250626 330-350600 464-306000	1 3 3 3
33	Hose Clamps	143-703000	2
34 ▲	Skt Hd Capscrews	404-750516	2
35 ▲	Skt Hd Capscrews	404-750428	4
36	Dragline Control Block Assembly (See E8)	555-1378	1
37 ▲	Male Coned Adaptor	446-630000	3
38	P.V.C. Covered Strap and Buckle	124-108900	2
39 ▲	Skt Hd Capscrews	404-750424	4
40	Hydraulic Tank Cover (See E5)	555-1357	1
41	Spacers for Ref. No. 32 Control Valve	555-1773	3
42	Pipe Header (Pan)	555-1840	1
43	Pipe Header (Frame) Complete with Hex Hd Bolts Hex Nuts Spring Washers	555-1841 460-350608 330-350600 464-306000	1 1 1 1
44 ▲	Skt Hd Capscrews	404-750532	2
45	Equal Tee	446-311000	1
46	Blanking Bar	555-1368	1
47	Adaptor Male	013-410000	1
48	Pump to Control Valve Hose	555-1895	1

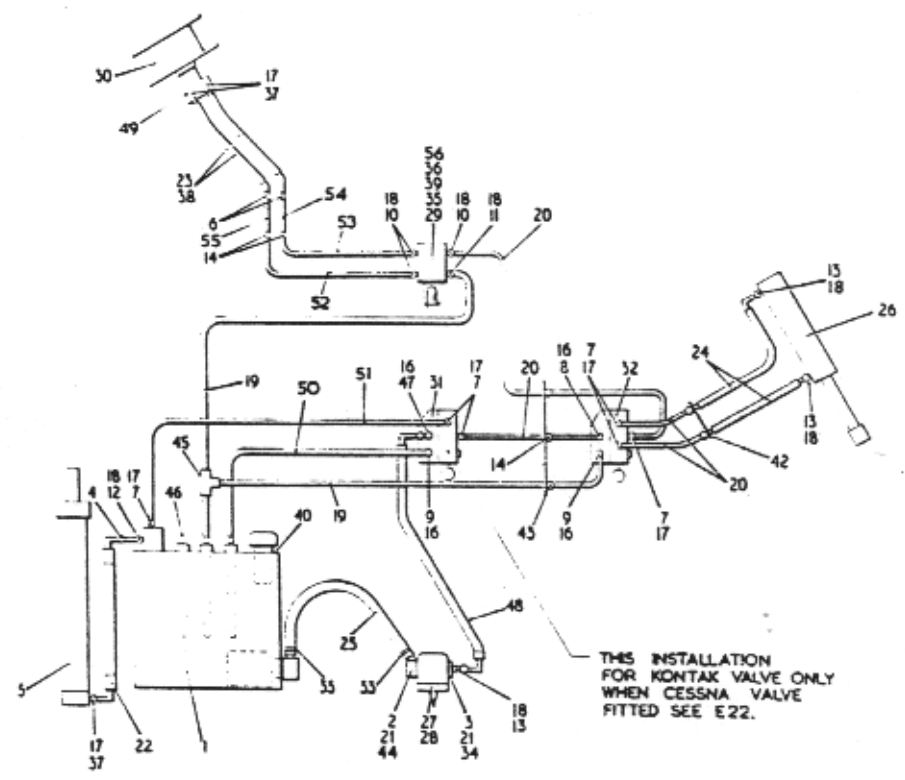

Ref N ^o	Description	Part N ^o	Qty
49	Port Block Complete with Screws and Seals	480-105015	1
50	Bright Steel Tube	555-1696	1
51	Bright Steel Tube	555-1690	1
52	Bright Steel Tube	555-1693	1
53	Bright Steel Tube	555-1692	1
54	Bright Steel Tube	555-1694	1
55	Bright Steel Tube	555-1695	1
56	Valve Cover Plate	555-1946	1

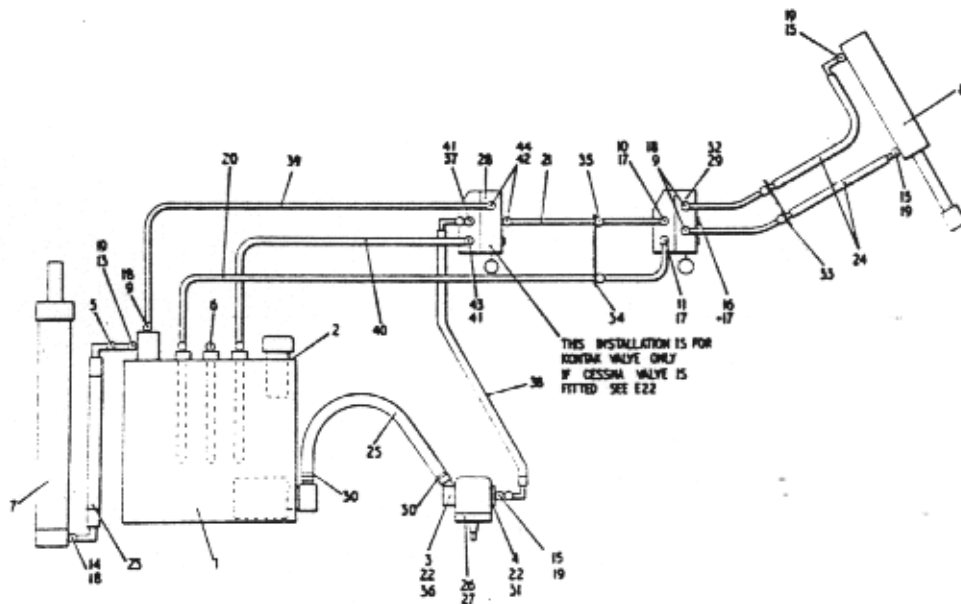

Ref No	Description	Part No	Qty
1	Hydraulic Tank Assembly (See E5)	555-1356	
2	Hydraulic Tank Cover Assembly (See E5)	555-1357	1
3	Pump Inlet Connector	555-1370	1
4	Pump Outlet Connector	555-1364	1
5	Connection for Flexible Pipe	513-1195	1
6	Blanking Bar	555-1368	1
7	Hopper Ram Assembly complete with Shroud (See E6)	555-1358	1
8	Double Acting Ram (See E18)	272-126000	1
9 ●	Male Stud Couplings	446-349000	3
10 ●	Male Stud Couplings	446-612000	2
11 ●	Male Stud Coupling	446-335000	1
12	—	—	—
13 □	Standpipe Adaptor	446-403000	1
14 ▲	Male Coned Adaptor	446-614000	1
15 ▲	Male Coned Adaptors	446-611000	2
16 ○	Brass Collared Plug	360-106000	1
17 *	Bonded Seals	417-806000	3
18 *	Bonded Seals	417-804000	4
19 *	Bonded Seals	417-803000	4
20	Bright Steel Tube — Length to suit	—	2
21	Bright Steel Tube — Length to suit	—	3
22 ■	'O' Rings	391-832000	2
23	Hopper Ram Hose	555-2043	1
24	Single Wire Hose Female Straight Female 90°	260-909000	2
25	Oil Resistant Hose (Blue)	260-908010	1
26	Pump (Diesel Machines Only) Complete with Hex Hd Bolts Binx Nuts	361-132000 460-350410	1 4
27	Pump (Electric Machines Only) Complete with Hex Hd Bolts Binx Nuts	330-360400 361-133000 460-350410 330-360400	4 1 4 4

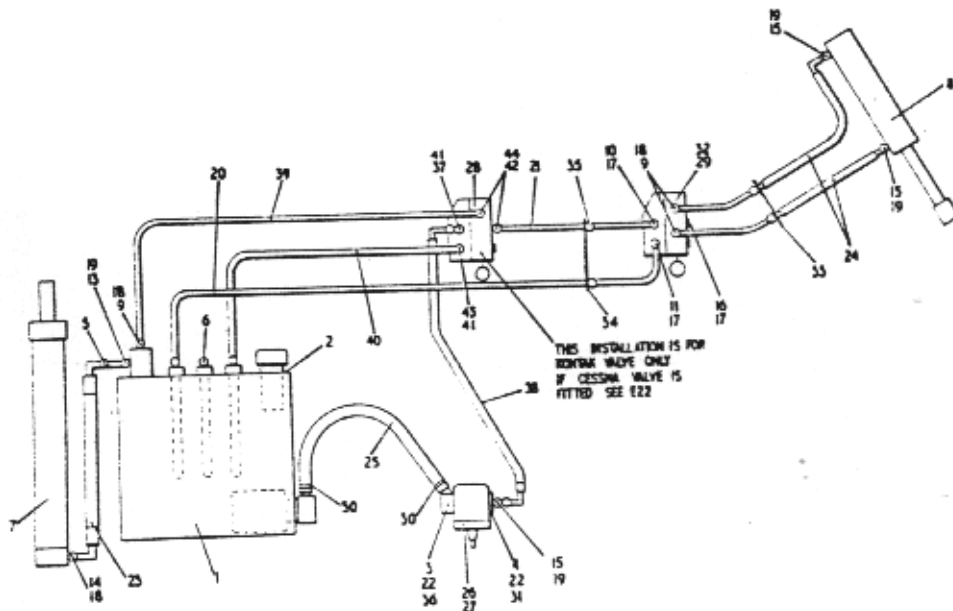

Ref No	Description	Part No	Qty
*28	Control Valve Complete with Hex Hd Setscrews Hex Nuts Spring Washers	451-431000 418-250620 330-350600 464-306000	1 3 3 3
29	Control Valve complete with Hex Hd Setscrews Hex Nuts Spring Washers	451-435000 418-250626 330-350600 464-306000	1 3 3 3
30	Hose Clamps	143-703000	2
31 Δ	Skt Hd Capscrews	404-750516	2
32	Spacers for Ref. No. 29 Control Valve	555-1773	3
33	Pipe Header (Pan)	555-1840	1
34	Pipe Header (Frame) Complete with Hex Hd Bolts Hex Nuts Spring Washers	555-1841 460-350608 330-350600 464-306000	1 1 1 1
35	Bulkhead Connection	446-488000	1
36 Δ	Skt Hd Capscrews	404-750532	2
*37	Adaptor Male	013-410000	1
38	Pump to Control Valve Hose	555-1895	1
39	Bright Steel Tube	555-1690	1
40	Bright Steel Tube	555-1696	1
*41 ●	Bonded Seals	417-806000	2
*42 ●	Male Stud Couplings	446-349000	2
*43 ●	Male Stud Coupling	446-335000	1
*44 *	Bonded Seals	417-804000	2
Items marked thus * are for 'Kontak' Control Valve only			

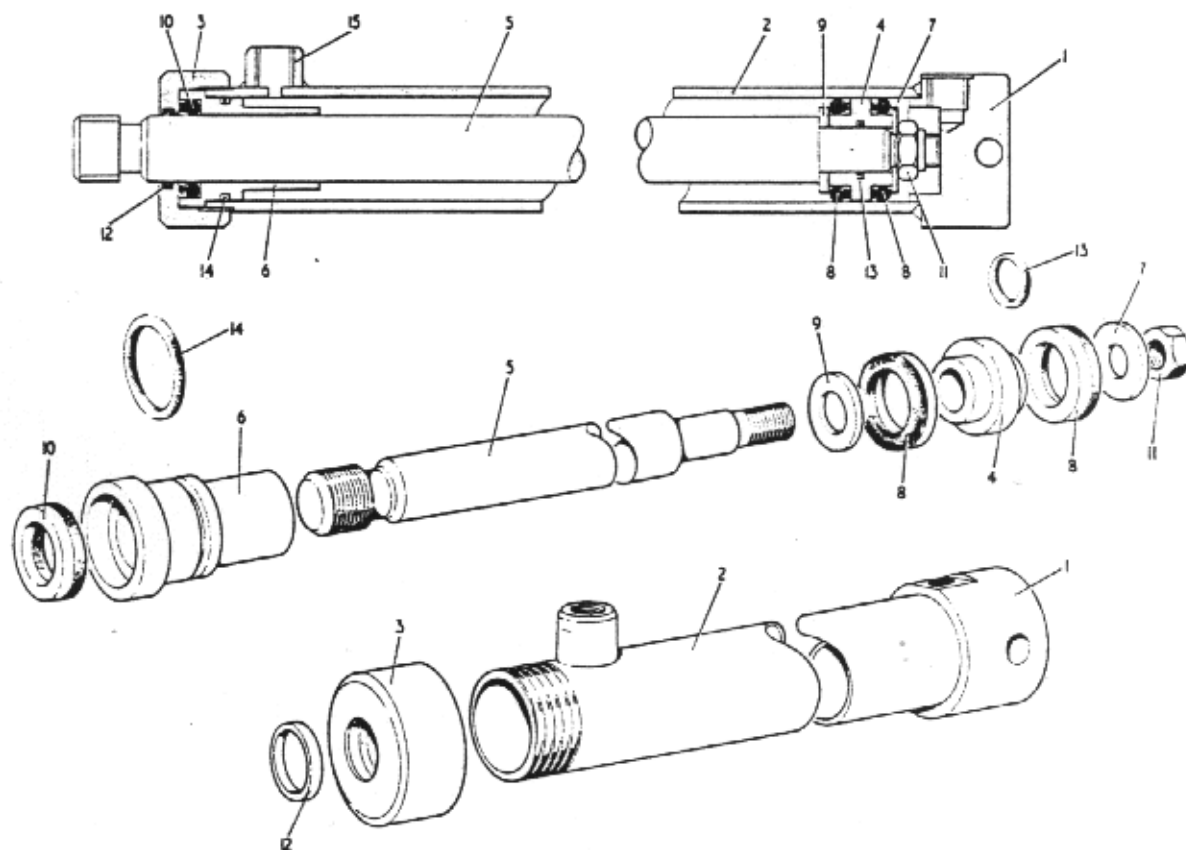

Ref N ^o	Description	Part N ^o	Qty
1	Cylinder Plug	3801	1
2	Cylinder	3602	1
3	Tube Cap	3603	1
4	Piston Head	3604	1
5	Piston Rod	3605	1
6	Tube Sleeve	3606	1
7	Backing Washer (Rear)	3607	1
8	Piston Seal	3609	2
9	Backing Washer (Front)	3618	1
10	Sleeve Seal	3819	1
11	Locknut	3621	1
12	Wiper	3622	1
13	Piston Head 'O' Ring	3623	1
14	Sleeve 'O' Ring	3620	1
15	Inlet Boss	3624	1

PAN DOOR RAM

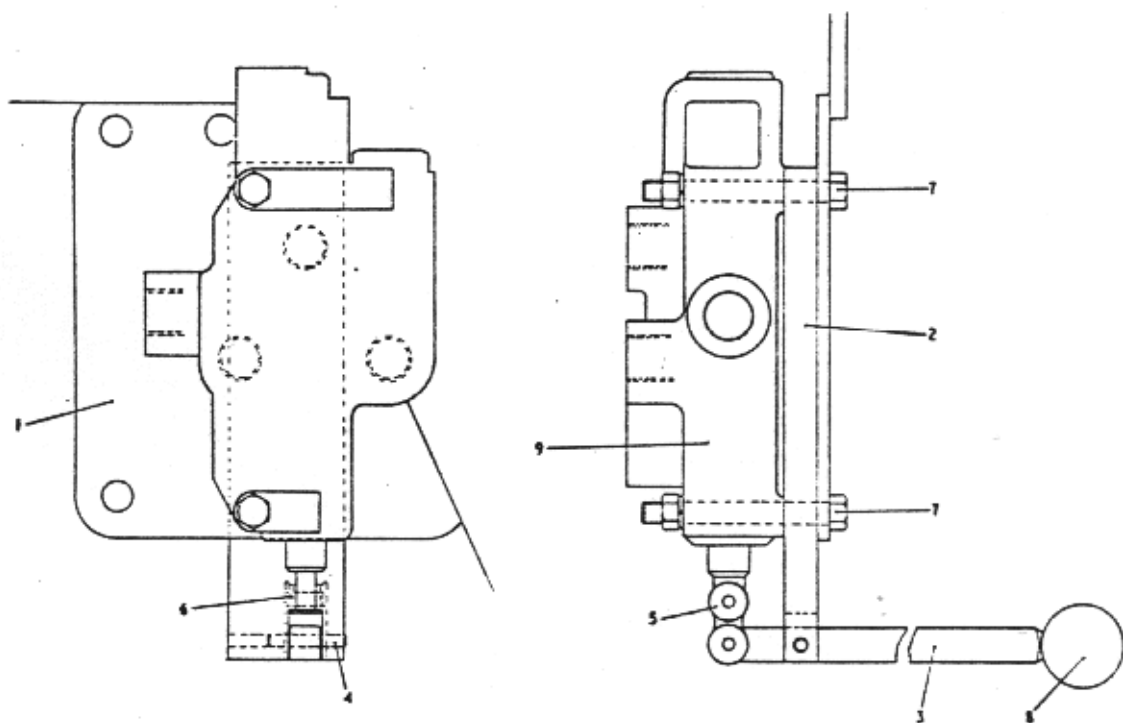

Ref N ^o	Description	Part N ^o	Qty
1	Hopper Valve Plate	555-1804	1
2	Lever Pivot	555-2054	1
3	Control Valve Operation Lever	555-2055	1
4	Spiral Pin	353-803120	1
5	Spring Connecting Link	310-105000	1
6	Washers	463-303000	As reqd.
7	Hex Hd Bolts complete with Hex Nuts Spring Washers	460-350522	2
		330-350500	2
		464-305000	2
8	Black Knob	307-140000	1
9	Cessna Valve	451-440000	1

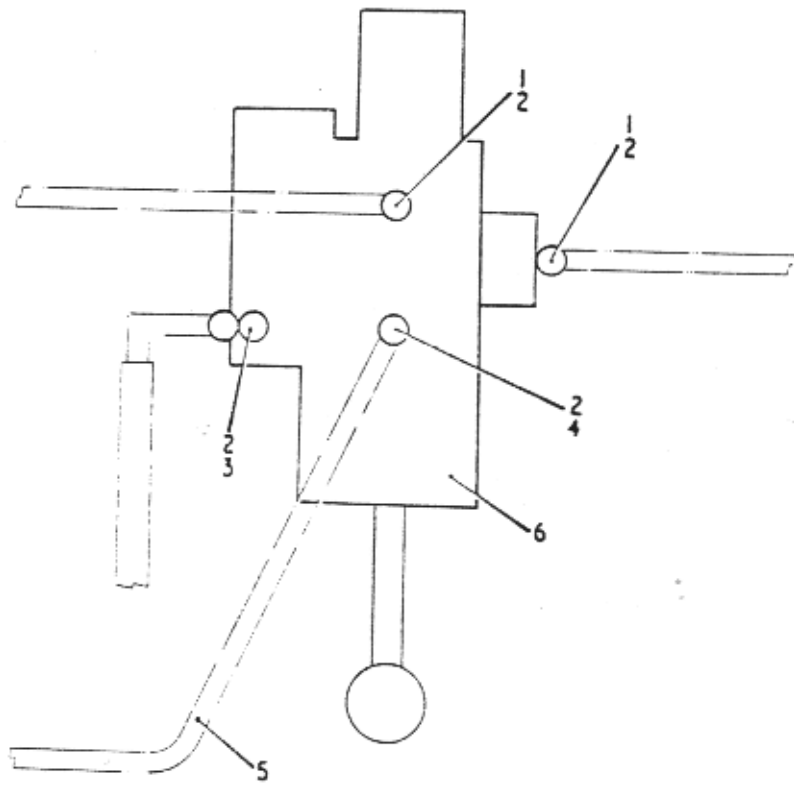

Ref N ^o	Description	Part N ^o	Qty
1 ●	Parallel Male Stud Couplings	446-628000	2
2 *	Bonded Seals	417-803000	4
3	Male Stud Adaptor	446-611000	1
4 ●	Parallel Male Stud Coupling	146-631000	1
5	Hydraulic Pipe (Cessna Valve to Tank)	555-2053	1
6	Cessna Valve complete with (See E21)	451-440000	1
	Hex Hd Bolts	460-350522	2
	Hex Nuts	330-350500	2
	Spring Washers	464-305000	2

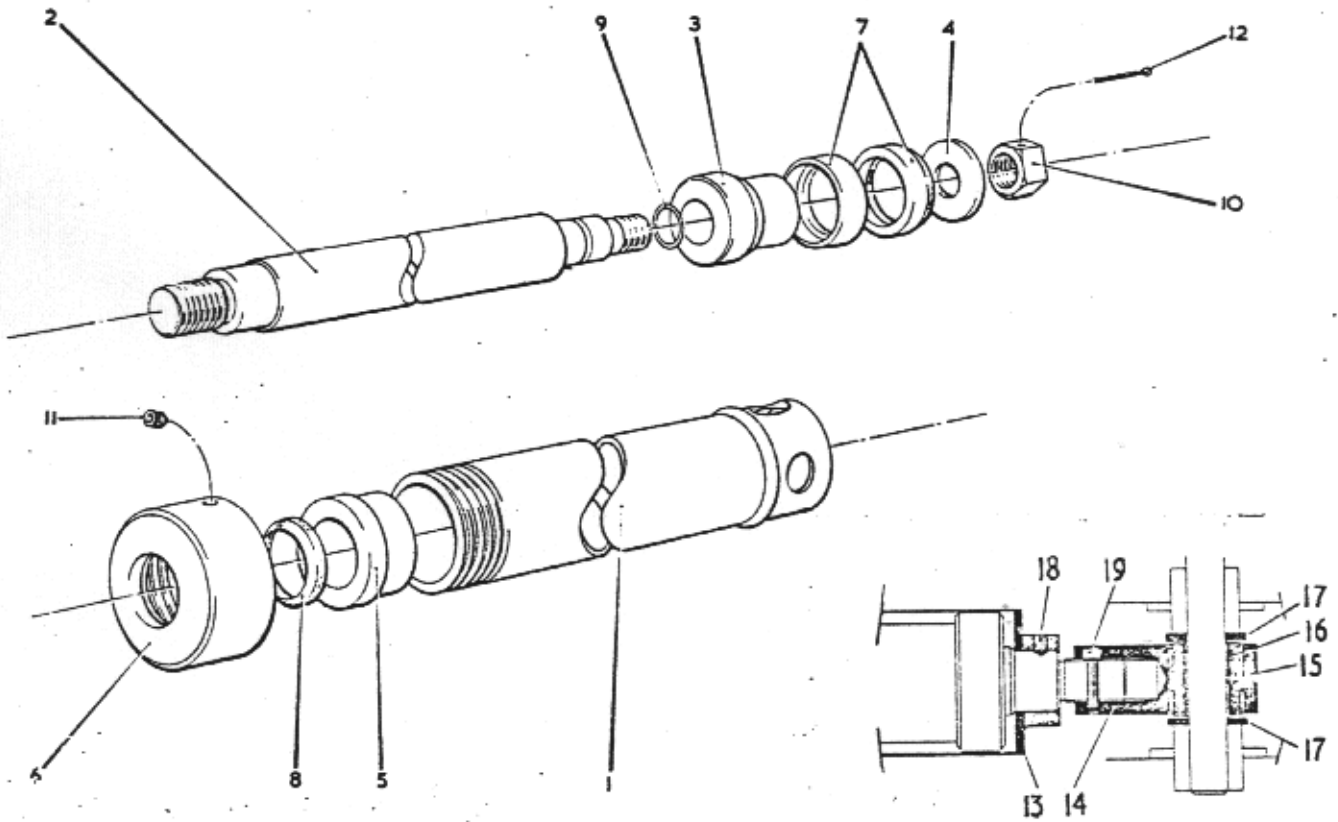

Ref No	Description	Part No	Qty	
*1	Tube Assembly	L.2750	272-130001	1
*2	Piston Rod	L.1747	272-127400	1
*3	Piston Head	L.1748	272-127300	1
*4	Backup Plate	L.1749	272-127600	1
*5	Front Insert	L.2752	272-127013	1
*6	Front Cap	L.2753	272-127012	1
*7	Piston Seal Assembly	L.1754	272-127800	1
*8	Wiper Seal	L.1755	272-127900	1
*9	'O' Ring	L.220	272-127100	1
*10	Nut	L.2754	272-127016	1
*11	Setscrew	L.1582	272-127011	1
*12	Cotter Pin	L.2755	272-127015	1
13	Ram Shroud		555-1367	1
14	End Piece for Ram		555-1366	1
15	Insert for Ram End		555-1365	1
16	Bush		112-801100	2
17	Bright Plain Washers		555-1679	2
18	Skt. Head Setscrew (Half Dog Pt.)		404-930606	1
19	Skt. Head Capscrews		404-706240	2
<p>* Items mark thus may be bought complete as: Hopper Ram Assembly Part No. 272-130000</p>				

Hopper Ram From M/C
No. 8201

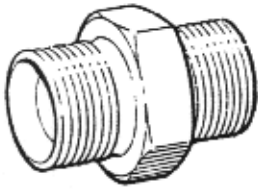

MALE CONE ADAPTOR

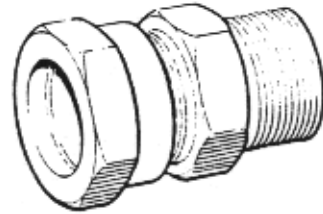

MALE STUD COUPLING

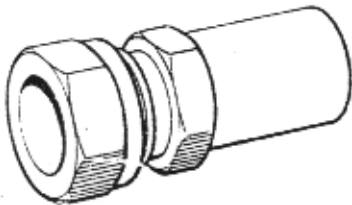

STANDPIPE ADAPTOR

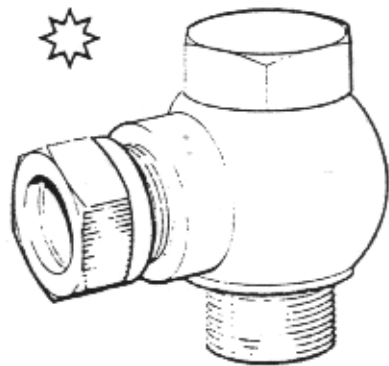

BANJO COUPLING

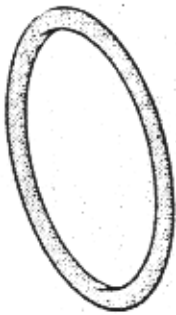

O RING

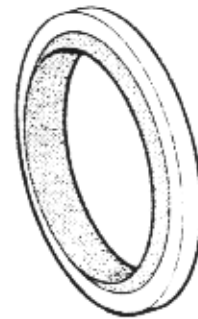

BONDED SEAL

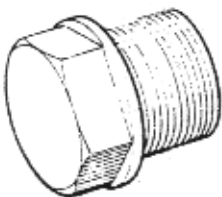

BRASS COLLARED PLUG

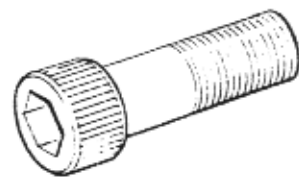

SOCKET HEAD CAPSCREW

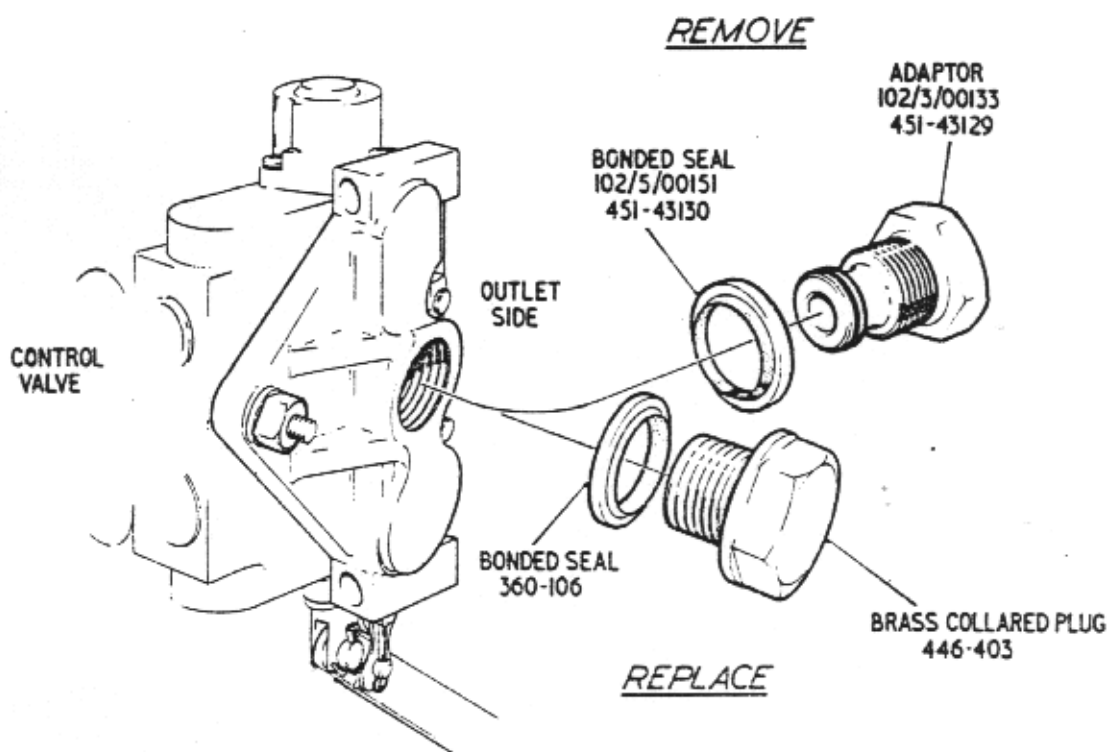

WHEN CONVERTING FROM DRAGLINE TO BASIC

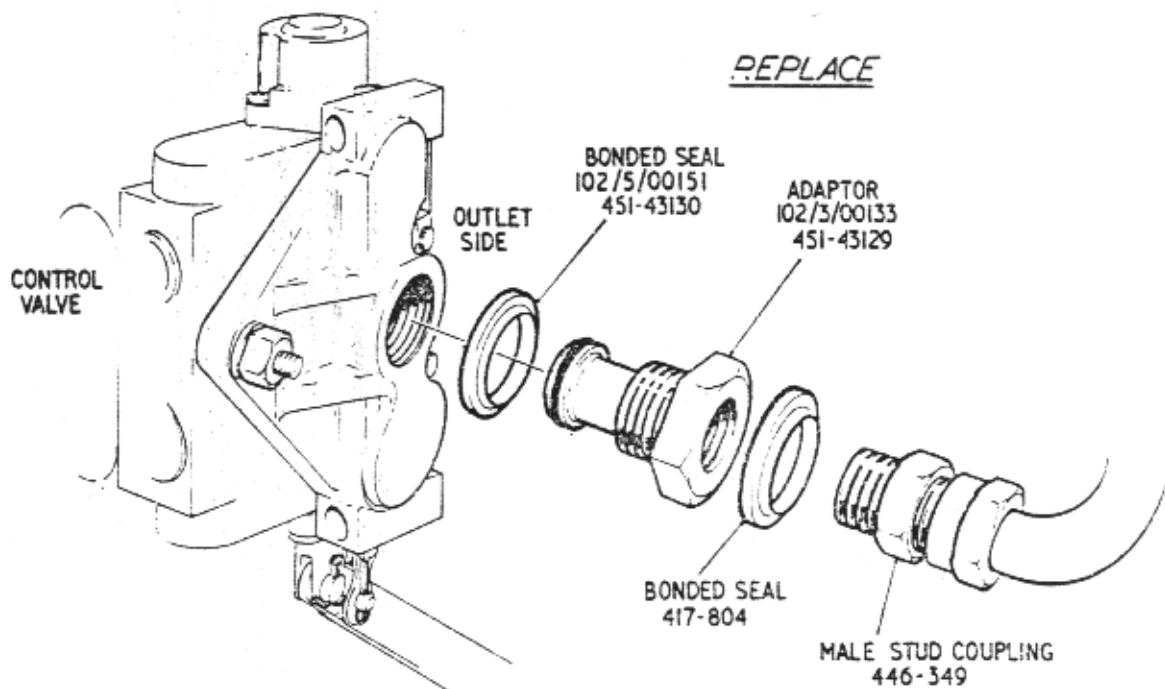

WHEN CONVERTING FROM BASIC TO DRAGLINE

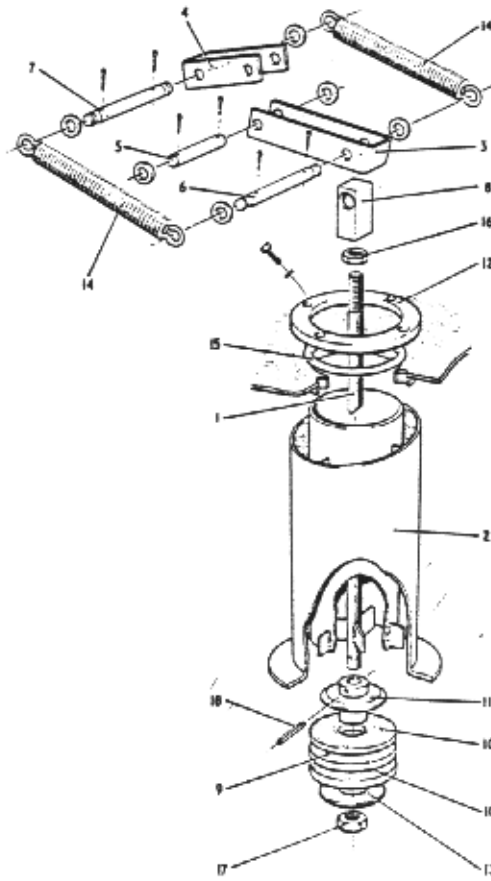

Ref N ^o	Description	Part N ^o	Qty
1	Valve Control Rod	555-1160	1
2	Syphon Cylinder Assembly	555-1161	1
3	Valve Link	555-1179	1
4	Ram Link	555-1178	1
5	Connecting Pin complete with	555-1174	1
	Plain Washers	464-308	2
	Split Pin	353-30610	2
6	Valve Pivot complete with	555-1173	1
	Plain Washer	463-308	2
	Split Pin	353-30610	2
7	Ram Pivot complete with	555-1172	1
	Plain Washer	463-309	2
	Split Pin	353-30412	2
8	Valve Rod Boss	555-1175	1
9	Centre Plate	555-1165	1
10	Valve Sealing	555-1184	2
11	Valve Backing Plate	555-1177	1
12	'O' Ring Flange complete with	555-1164	1
	Hex Hd. Setscrews (Cadmium Plated)	418-3506051	4
	Selon Washers	464-809	4
13	Valve Washer	555-1166	1
14	Tension Spring	420-429	2
15	'O' Ring	391-350	1
16	Locknut	330-2508	1
17	'Binx' Self-Locking Nut	335-7608	1
18	Roll Pin (Cadmium Plated)	353-803241	1

WATER TANK MECHANISM

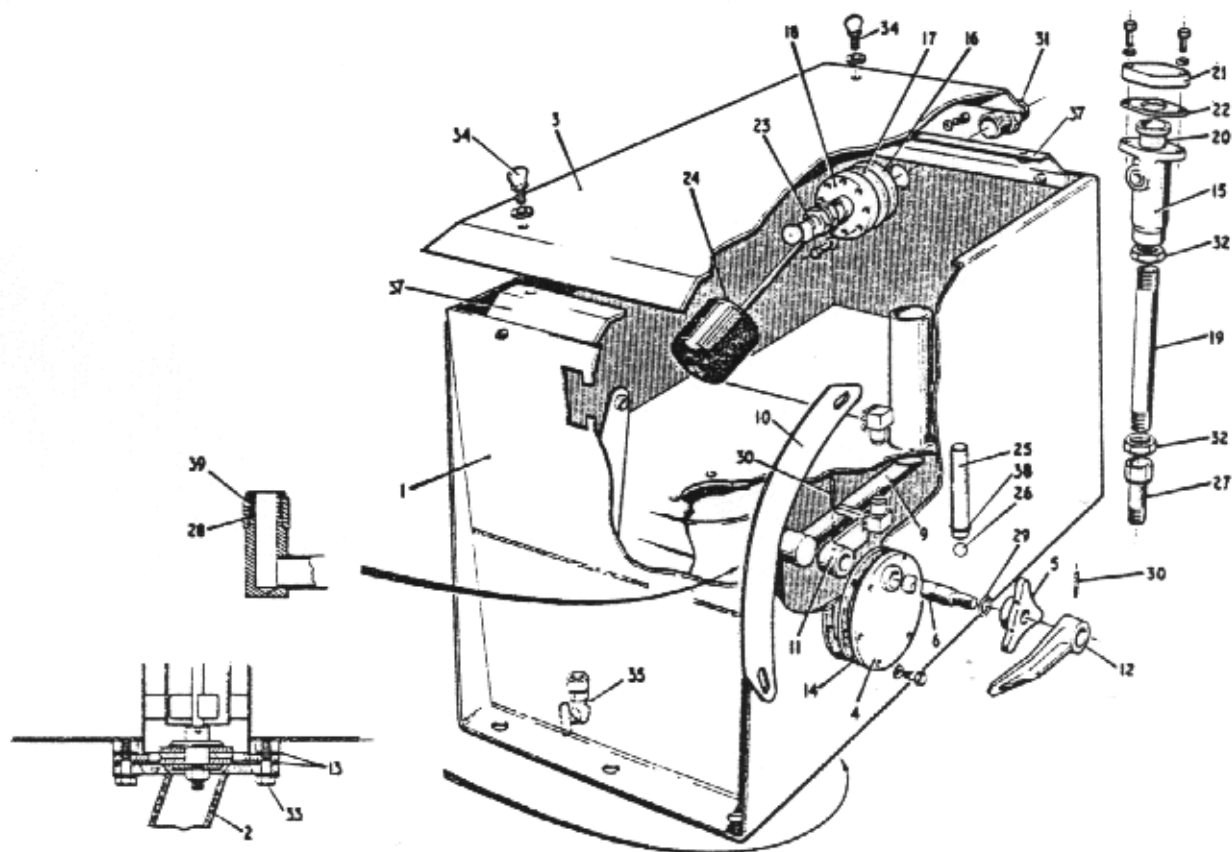

Ref No	Description	Part No	Qty
1	12 Gallon Water Tank complete with Hex Hd Bolts Hex Nuts Spring Washers	555-1188 460-350808 331-8508 464-308	1 6 6 6
2	Water Outlet Pipe	555-1195	1
3	Water Tank Cover	555-1159	1
4	Pivot Housing complete with Hex Hd Bolts Selon Washers	555-1155 460-350508 464-807	1 6 6
5	Handle	555-1158	1
6	Pivot Shaft	555-1171	1
7	—	—	—
8	—	—	—
9	Syphon Break Tube	555-1153	1
10	Tank Scale (12 Gallon Tank) Litres 8 Gallons complete with Hex Hd Setscrews Plain Washers	555-1190 418-250606 463-306	1 2 2
11	Pivot Lever	555-1156	1
12	Pointer	555-1157	1
13	Rubber Joint	555-1185	2
14	Tank Gasket	555-1186	1
15	Strainer Body	50-29172	1
16	Float Valve Body complete with Hex Hd Setscrews Spring Washers	614-1273 418-350504 464-305	1 2 2
17	Diaphragm	614-1266	1
18	Float Valve Cover complete with Hex Hex Bolts Selon Washers	614-1278 460-50410 464-304	1 8 8
19	Water Supply Pipe	50-28583	1
20	Strainer Element	50-29174	1

WATER TANK

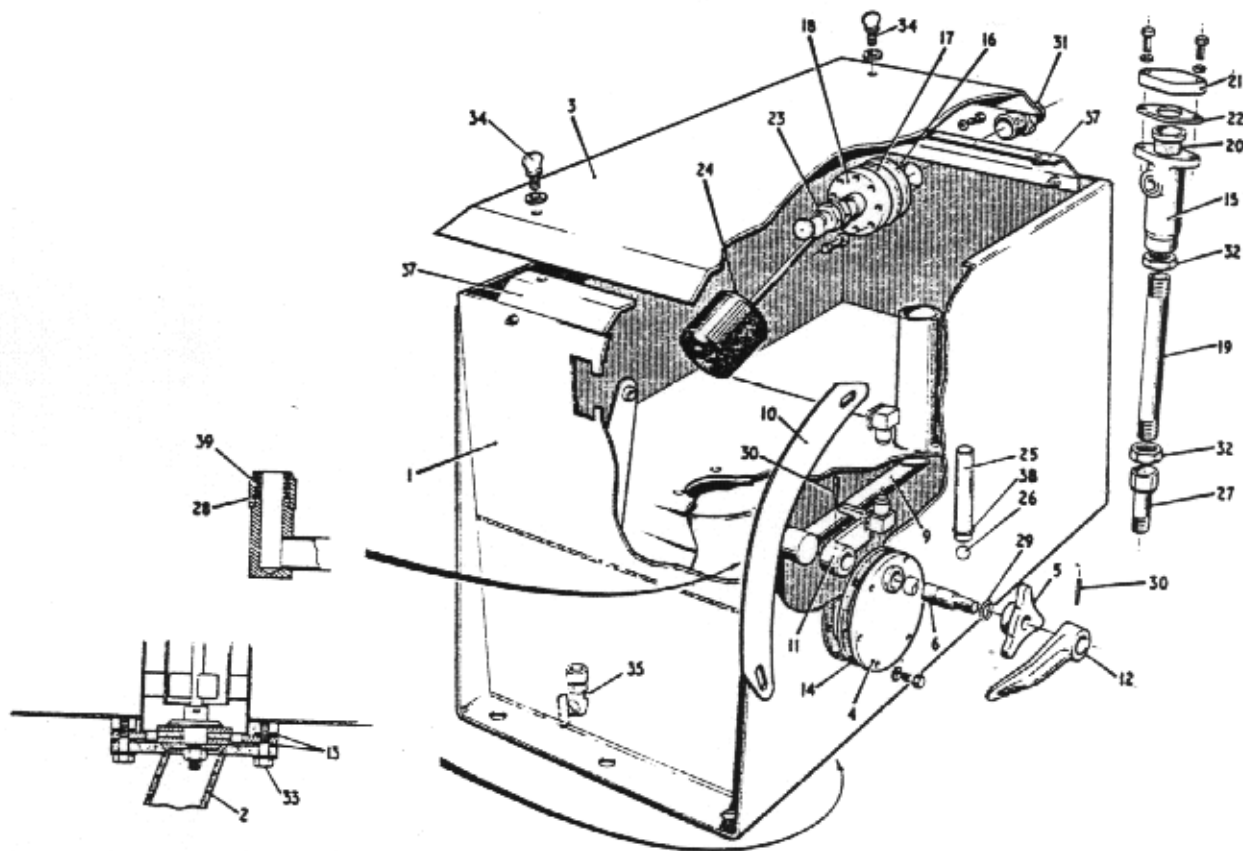

Ref N ^o	Description	Part N ^o	Qty
21	Strainer Body Cap complete with Hex Hd Setscrews Spring Washers	50-29175 418-350508	1 2
22	Strainer Cap Gasket	464-305	2
23	Ball Float Valve	50-29177	1
24	Polythene Float	451-1081	1
25	Plastic Tube	220-302	1
26	Ball	430-904	1
27	Hose Connection	101-256	1
28	'O' Ring	130-31212	1
29	'O' Ring	391-828	1
30	Taper Pin	391-825	1
31	Reducing Nipple	352-10814	2
32	Backnut	245-40806	1
33	Hex Hd Bolts complete with Selon Washers	240-106 460-50714	2 4
34	Thumbscrew complete with Plain Washers	464-809 407-310506	4 4
35	Draincock	463-305	4
36	Water Tank Stowage Bracket complete with Hex Hd Bolts Hex Nuts Spring Washers (Not Illustrated)	140-802 555-1673 460-50626 331-8506 464-306	1 2 4 4 4
37	Water Tank Cover Bracket complete with Hex Hd Bolts Hex Nuts Spring Washers	555-1867 460-50505 331-8505 464-305	2 4 4 4
38	Hose Clamp	143-106	1
39	Brass Bush	555-1181	1

WATER TANK

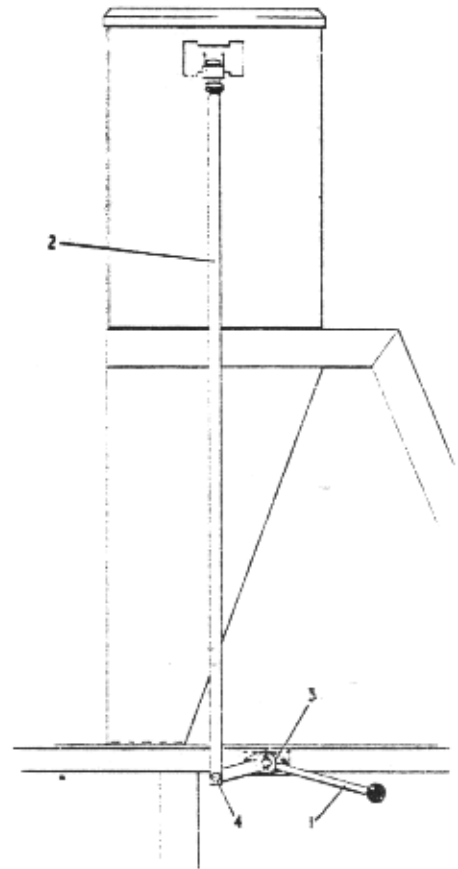
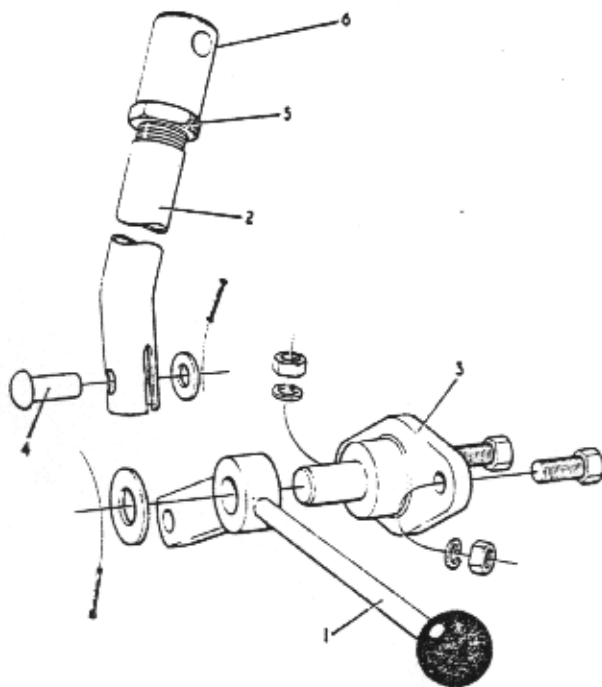

Ref N ^o	Description	Part N ^o	Qty
1	Water Control Lever	555-1200	1
2	Tank Operating Rod	555-1205	1
3	Control Lever Pivot complete with	555-1199	1
	Hex Hd Bolts	460-350610	2
	Hex Nuts	330-3506	2
	Spring Washers	464-306	2
	Plain Washer	463-312	1
	Split Pin	353-30412	1
4	Lever Rod connection Pin complete with	555-1202	1
	Plain Washer	463-305	1
	Split Pin	353-3036	1
5	Locknut	240-104	1
6	End Piece for Tank Operating Rod	555-1702	1

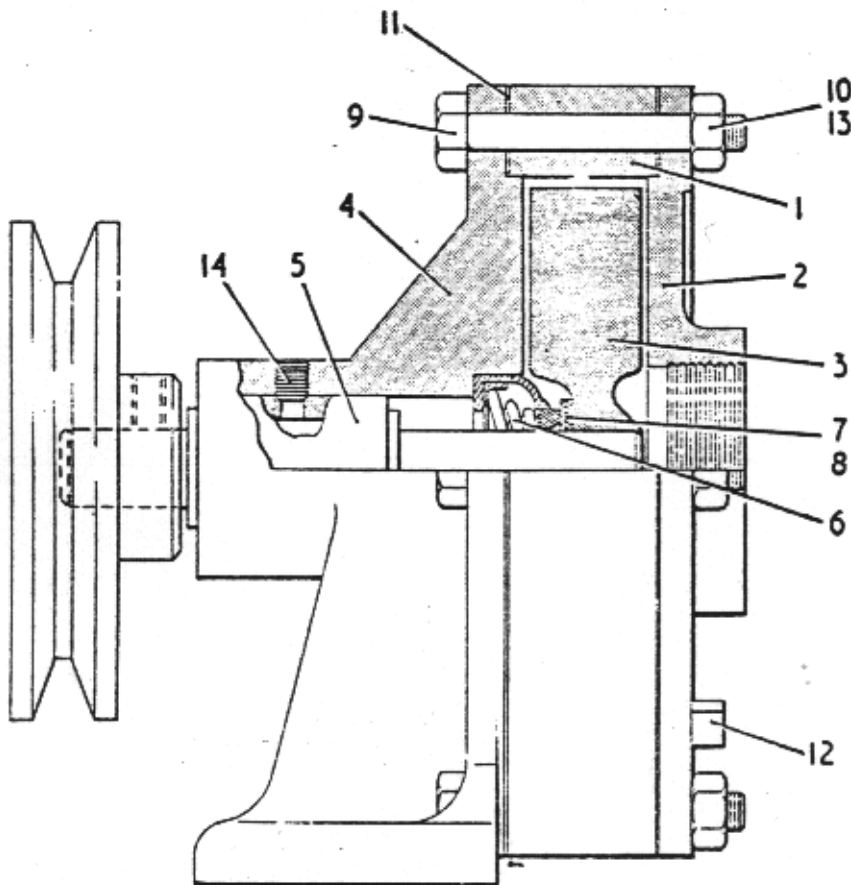

Ref N ^o	Description	Part N ^o	Qty
1	Body —	11-053-015	1
2	Front Cover —	11-055-0115	1
3	Impellor —	12-068-0125	1
4	Bearing Pedestal —	13-059-0125	1
5	Spindle —	16-072-083	1
6	Dupax Seal —	38-840-992	1
7	Seal Seat —	38-842-061	1
8	Seal Rubber —	38-843-133	1
9	Hex. Head Bolt —	32-561-052	4
10	Hex. Nut —	34-161-082	4
11	Gasket —	38-158-133	2
12	Plug —	30-023-992	2
13	Lockwasher —	36-563-992	4
14	Grubscrew —	32-622-052	1
15	Name Plate —	47-011-023 (Not Illustrated)	1
16	Stud —	34-650-022 (Not Illustrated)	4

Item No. 14 is not fitted on Mk II Pumps
it is Loctighted in position

WATER PUMP USED WHEN WATER METER IS FITTED

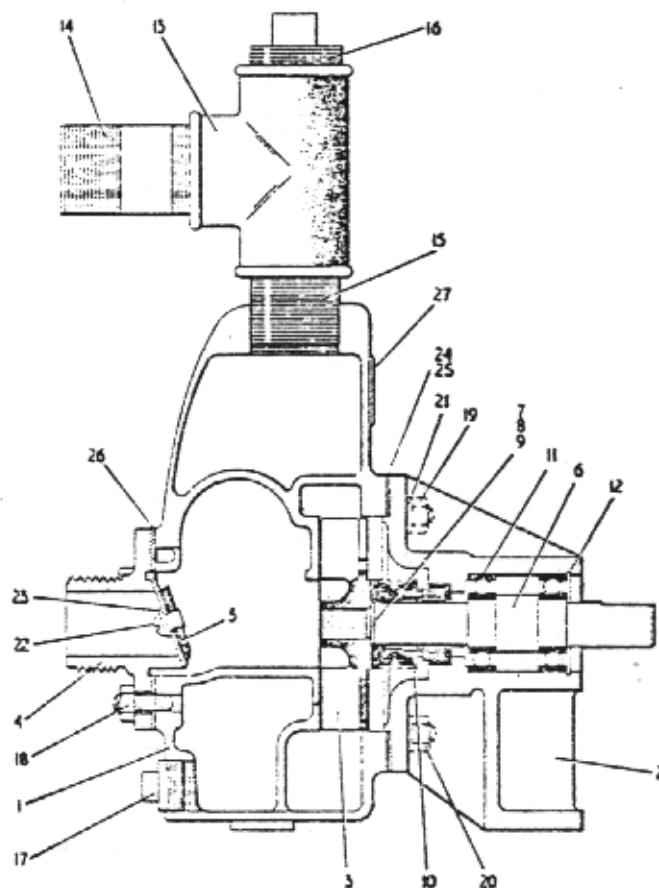

Ref No	Description	Part No	Qty
1	Casing - HD 13869	365/235/001	1
2	Bearing Housing - HD 10471	365/235/002	1
3	Impeller - HD 15069	365/235/003	1
4	Suction Flange - HU 15003	365/235/004	1
5	Valve Weight - HD 10571	365/235/005	1
6	Shaft - HD 10671	365/235/006	1
7	Impeller Shim .005" - 1W5	365/235/007	As Req.
8	Impeller Shim .010" - 1W10	365/235/008	As Req.
9	Impeller Shim .015" - 1W15	365/235/009	As Req.
10	Shaft Seal - 5-T106	365/235/010	1
11	Bearing - 6003 2RS	365/235/011	1
12	Circlip - 1300 - 35m	365/235/012	1
13	Discharge Tee - 7R - 8T	365/235/013	1
14	Space Nipple 6W - 8N	365/235/014	1
15	Close Taper Nipple 19W-8N	365/235/015	1
16	Priming Plug - 85R - P8	365/235/016	1
17	Drain Plug 85R - P6	365/235/017	1
18	Suction Flange Stud 4NC7	365/235/018	3
19	Casing Stud - 4NC7	365/235/019	4
20	Hexagon Nut - 4NC	365/235/020	7
21	Spring Washer - 4SW	365/235/021	4
22	Valve Weight Screw - 4NC 2SR	365/235/022	1
23	Valve Weight Washer - 4W	365/235/023	1
24	Casing Gasket 1/64 in. - HD 5569	365/235/024	
25	Casing Gasket 1/32 in. - HD 15669	365/235/025	
26	Check Valve Gasket - HD 15469	365/235/026	1
27	Nameplate - HD 109695	365/235/027	1

WATER PUMP WITH WASHDOWN ONLY

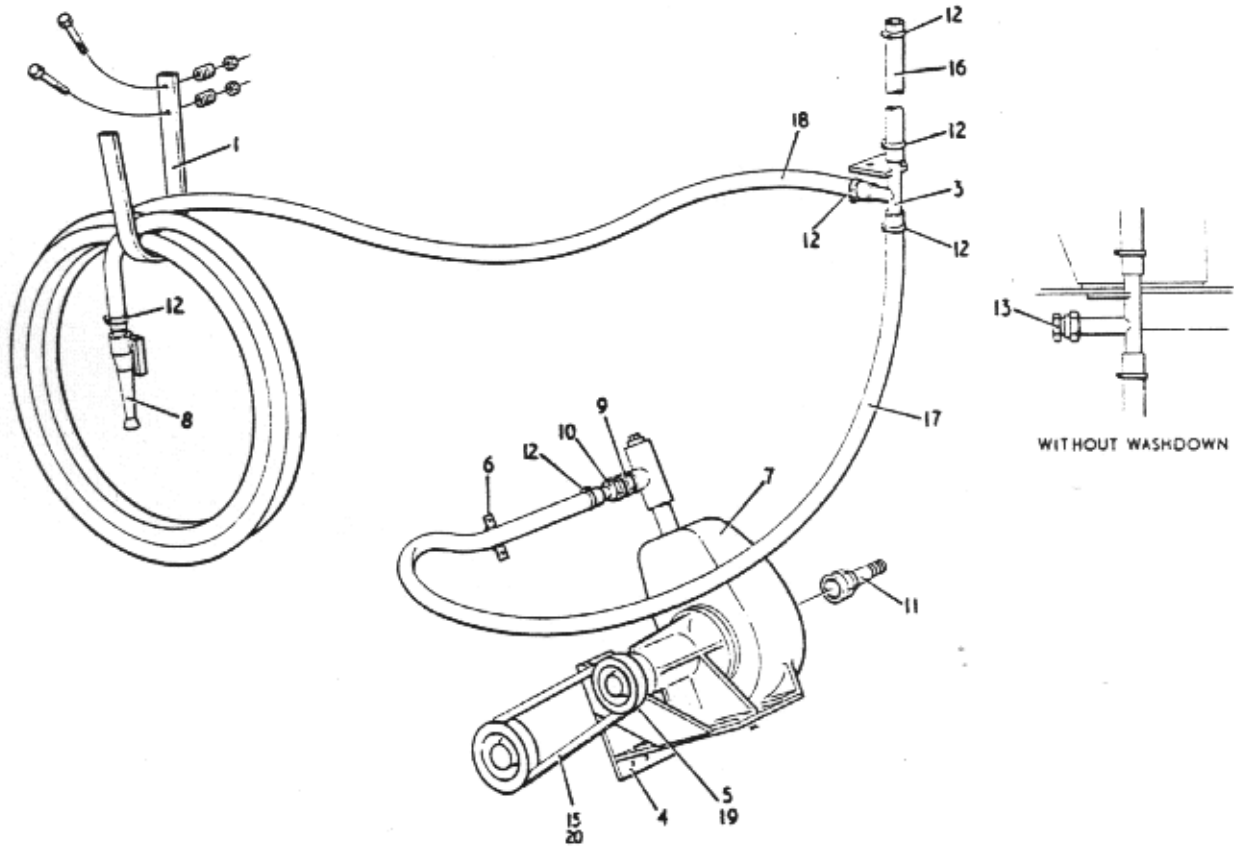

Ref N ^o	Description	Part N ^o	Qty
1	Washdown Hose Support complete with Hex Hd Bolt Hex Nut Spring Washers Plain Washers	555-1758 460-350614 330-3506 464-306 463-306	+ 1 2 2 2 As Req.
2	Water Pump Warning Label (Not Illustrated)	555-1776	1 1
3	Hose Adaptor Pipe complete with Hex Hd Bolt Hex Nut Spring Washers	555-1777 418-250812 330-3508 464-308	1 1 1 1 1 1 1 1
4	Water Pump Mounting complete with Hex Hd Bolts Binx Nut	555-1780 460-350506 330-3605	1 1 4 4 4 4
5	Water Pump Pulley	555-1778	1 1
6	Conduit Pipe Clip complete with Hex Hd Bolts Hex Nuts Spring Washers	133-908 460-3301004 330-35210 464-304	1 1 2 2 2 2 2 2

WASHDOWN SYSTEM WITHOUT WATER METER

+With Wash Down
*Less Wash Down

When Ordering Always Quote :— Machine N^o, Part N^o, Description & Quantity

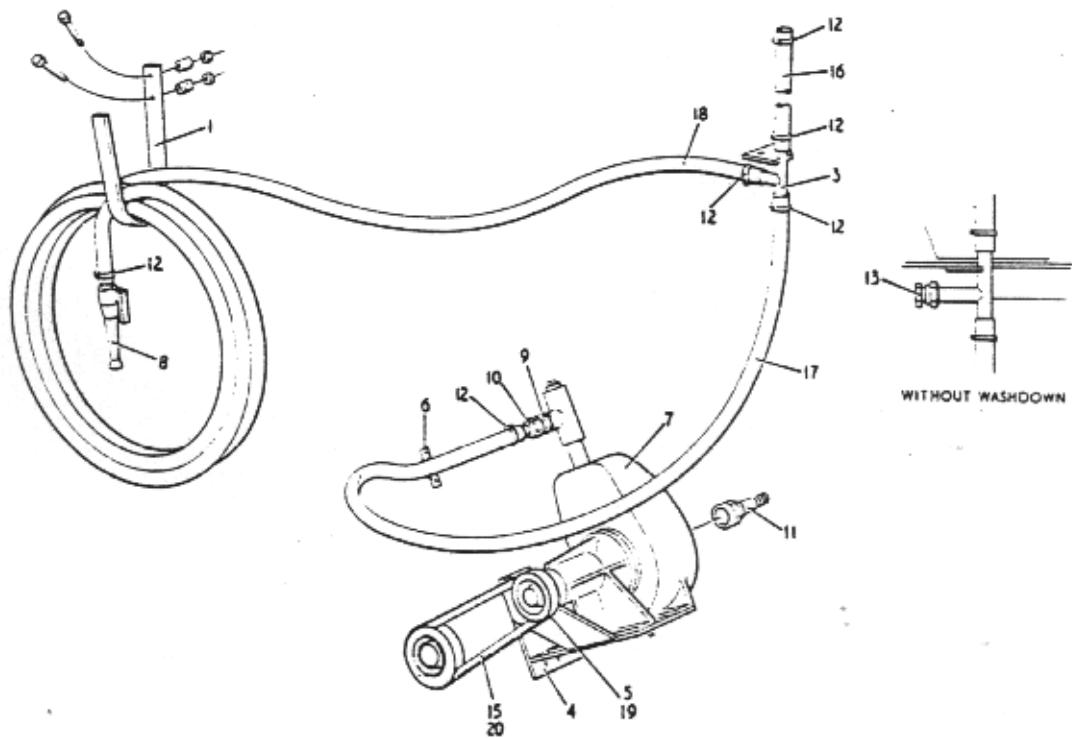

Ref N ^o	Description	Part N ^o	Qty
7	Water Pump complete with Hex Hd Bolts Sinx Nuts Plain Washers	365-235000 460-350406 330-360400 463-304000	+ * 1 1 4 4 4 4 4 4
8	Plastic Control Nozzle	130-352000	1 -
9	Reducing Nipple Male/Male	245-408060	1 1
10	Brass Hose Connector	130-312160	1 1
11	Brass Hose Connector	130-316120	1 1
12	Clip	132-856000	6 4
13	Blank End	446-655060	- 1
14	-	-	- -
15	'V' Belt	397-609000	1 1
16	Hose - 1220mm (4' 0") Long	260-906480	1 1
17	Hose - 2440mm (8' 0") Long	260-906960	1 1
18	Hose - 6095mm (20' 0") Long	260-906240	1 -
19	Skt Hd Setscrew Cone PT.	404-910406	1 1
20	'V' Belt (Used when Dynamo is fitted)	397-234000	1 1

WASHDOWN SYSTEM WITHOUT WATER METER

+With Wash Down

*Less Wash Down

When Ordering Always Quote — Machine N^o, Part N^o, Description & Quantity

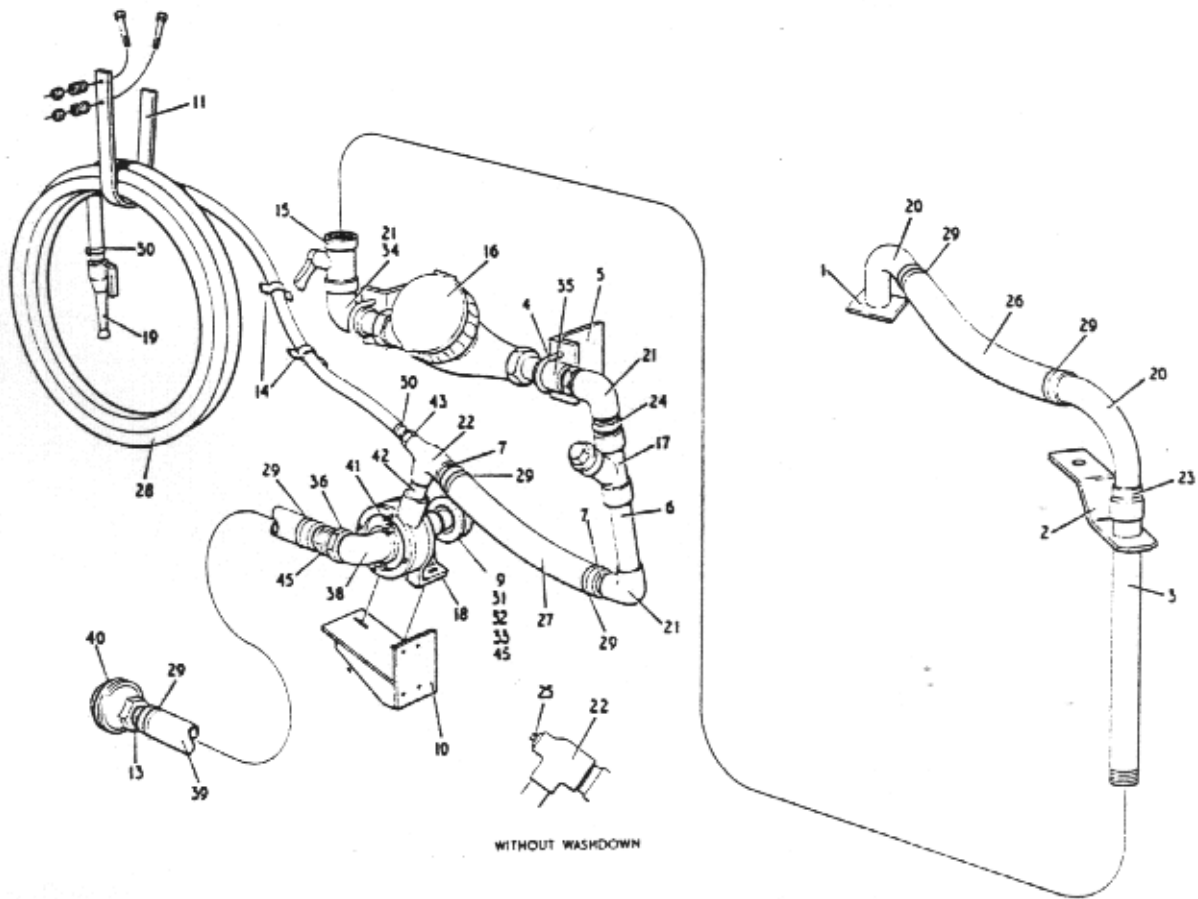

Ref No	Description	Part No	Qty
1	Water Pipe Connecting Plate complete with Hex Hd Bolt Hex Nut Spring Washer	555-1763 460-350606 330-3506 464-306	1 1 1 2 2 2 2 2 2 2 2 2
2	Water Pipe Clip complete with Hex Hd Bolt Hex Nut Spring Washer	555-1767 460-50810 331-8508 464-308	1 1 1 1 1 1 1 1 1 1 1 1
3	Water Pipe	555-1766	1 1 1
4	'U' Bolt for Flowmeter complete with Hex Nuts Spring Washers	555-1765 330-3506 464-306	2 2 2 4 4 4 4 4 4
5	Flowmeter Mounting Bracket	555-1768	2 2 2
6	Connecting Pipe	555-1760	1 - 1
7	Insert for Valve	555-1764	2 - 2
8	Mod to Side Guard-RH Not Illustrated	555-1844	- - 1
9	Water Pump Pulley	555-1762	1 - 1
10	Water Pump Bracket complete with Hex Hd Bolt Binx Nut	555-1761 460-350506 330-3605	1 - 1 4 - 4 4 - 4
11	Washdown Hose Support complete with Hex Hd Bolt Hex Nut Spring Washers Plain Washers	555-1758 460-350614 330-3506 464-306 463-306	- - 1 - - 2 - - 2 - - 2 - - 2
12	Water Pump Warning Label (Not Illustrated)	555-1776	1 - 1

WATER PUMP & WATER METER

- Pump Feed only
- ▲ Mains Feed only
- Pump Feed & Washdown

When Ordering Always Quote :— Machine No, Part No, Description & Quantity

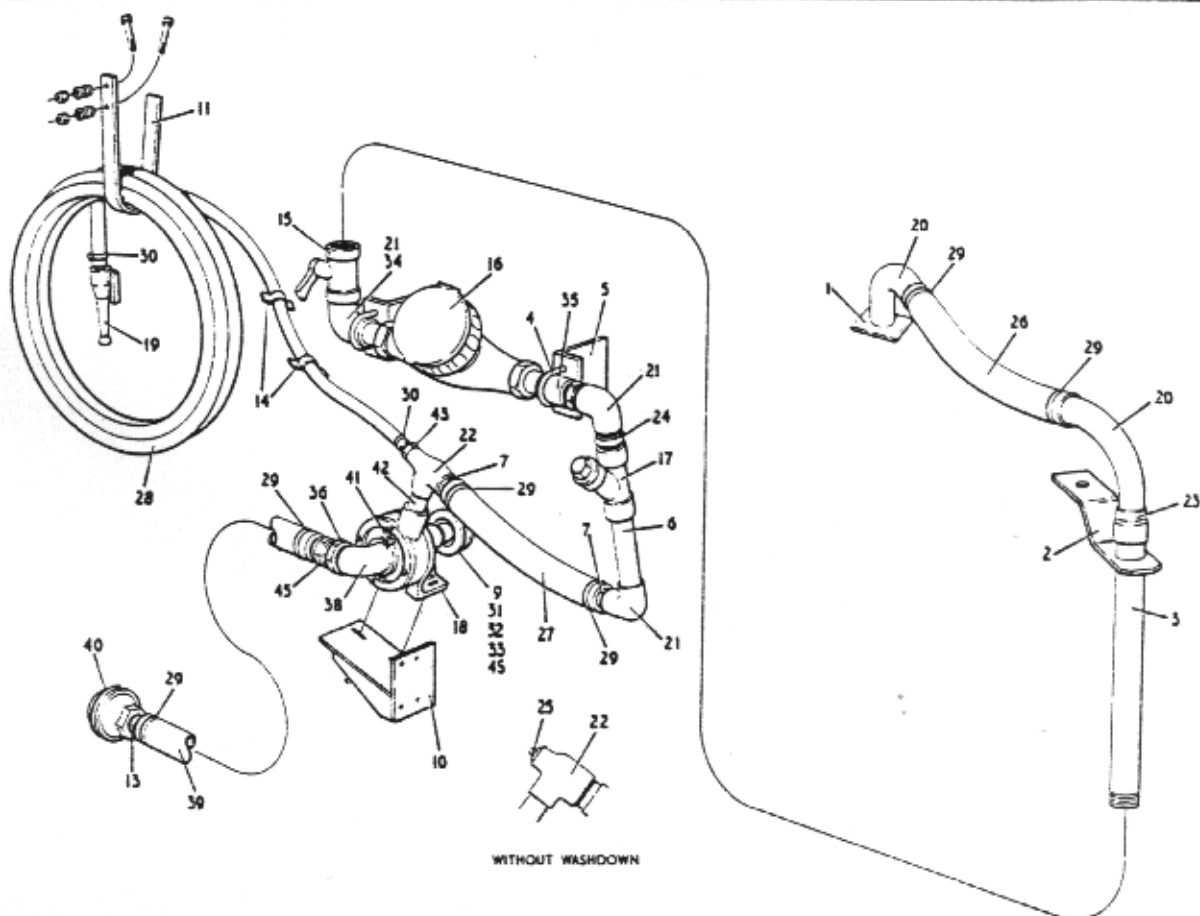

Ref N ^o	Description	Part N ^o	Qty
13	Hose Connector	555-1796	1 - 1
14	Conduit Pipe Clip complete with Hex Hd Bolt Hex Nuts Spring Washers	133-908 460-3301004 330-35210 464-304	- - 2 - - 4 - - 4 - - 4
15	Valve	450-151	1 1 1
16	Flowmeter	202-319	1 1 1
17	'Y' Type Strainer	409-255	
18	Water Pump complete with Hex Hd Bolts Binx Nut Plain Washers	365-237 460-350610 330-3606	1 - 1 2 - 2 2 - 2
19	Plastic Control Nozzle	463-306	2 - 2
20	Bend	130-352	- - 1
21	Elbow	240-210	2 2 2
22	Female Reducing Tee	241-112	3 2 3
23	Reducing Socket	242-65408	1 - 1
24	Hex Nipple	242-112/10	1 1 1
25	Plug	243-912	2 2 2
26	Hose 356mm 14" Long	241-704	1 - -
27	Hose 356 mm 18" Long	260-91214	1 1 1
28	Water Delivery Hose 20' - 0" Long	260-91218	1 - 1
		260-906240	- - 1

WATER PUMP & WATER METER

- Pump Feed only
- ▲ Mains Feed only
- Pump Feed & Washdown

When Ordering Always Quote :— Machine N^o, Part N^o, Description & Quantity

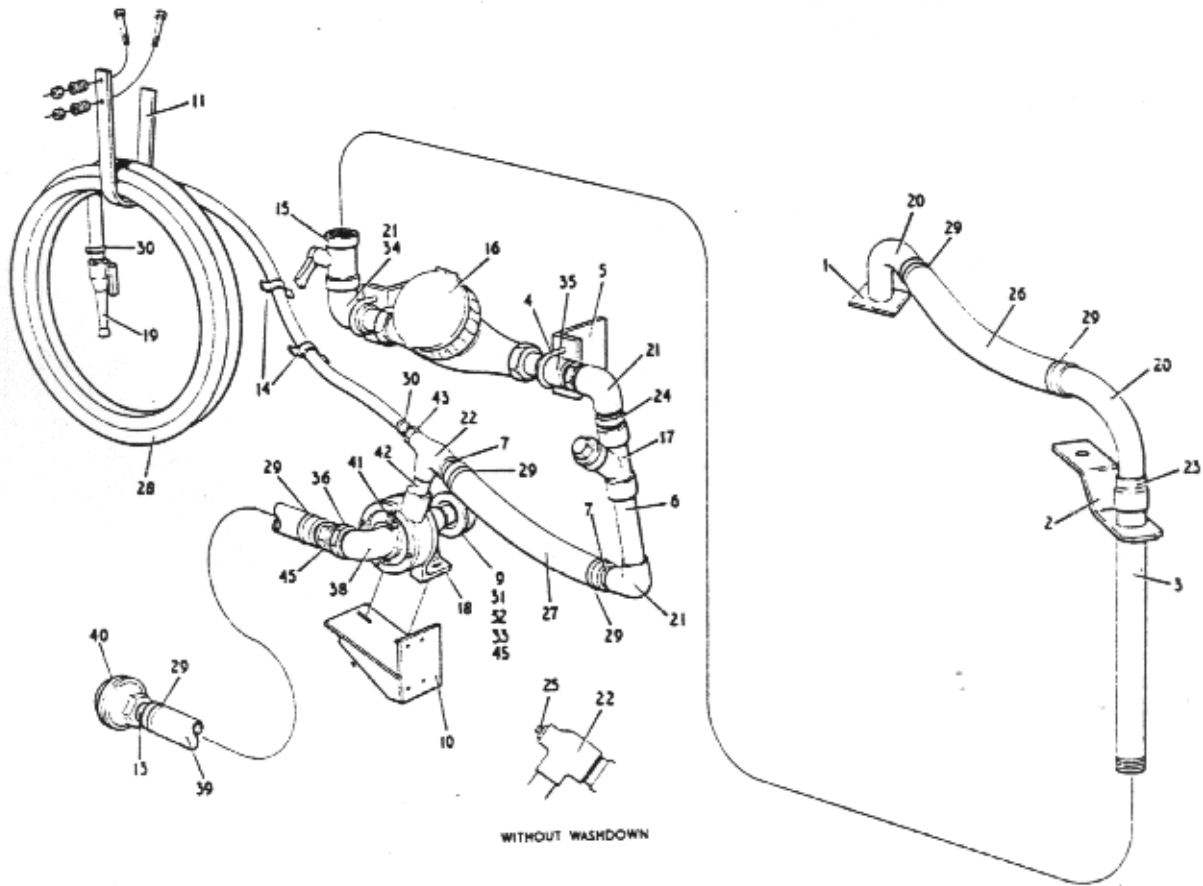

Ref No	Description	Part No	Qty
			● ▲ ■
29	Clip	143-108	6 2 6
30	Clip	132-856	- - 2
31	V Belt (Diesel Machines Only)	397-229000	1 - 1
32	V Belt (Electric Machines Only)	397-230000	1 - 1
33	Cone PT. Skt. Setscrews	403-560406	1 - 1
34	Running Nipple	241-512	1 1 1
35	Socket	241-912	1 1 1
36	Hex Nipple	241-510	1 - 1
37	Brass Hose Connector	130-32020	1 - 1
38	Male/Female Elbow	240-710	1 - 1
39	Hose 3048mm 10' - 0" Long	260-912120	1 - 1
40	Foot Valve & Strainer	409-256	1 - 1
41	Straight Brass Drain Tap (Taper Thread)	440-10101	1 - 1
42	Barrel Nipple	245-308	1 - 1
43	Straight Brass Male Hose Connector	130-20401	- - 1
44	Control Side Cover (Not Illustrated)	555-1845	1 - 1
45	⊗ V-Belt (Used when Dynamo is fitted)	397-238000	1 1 1
⊗ Item marked thus replaces Ref. No. 31 or 32 when Dynamo is fitted.			

WATER PUMP & WATER METER

- Pump Feed only
- ▲ Mains Feed only
- Pump Feed & Washdown

When Ordering Always Quote — Machine No, Part No, Description & Quantity

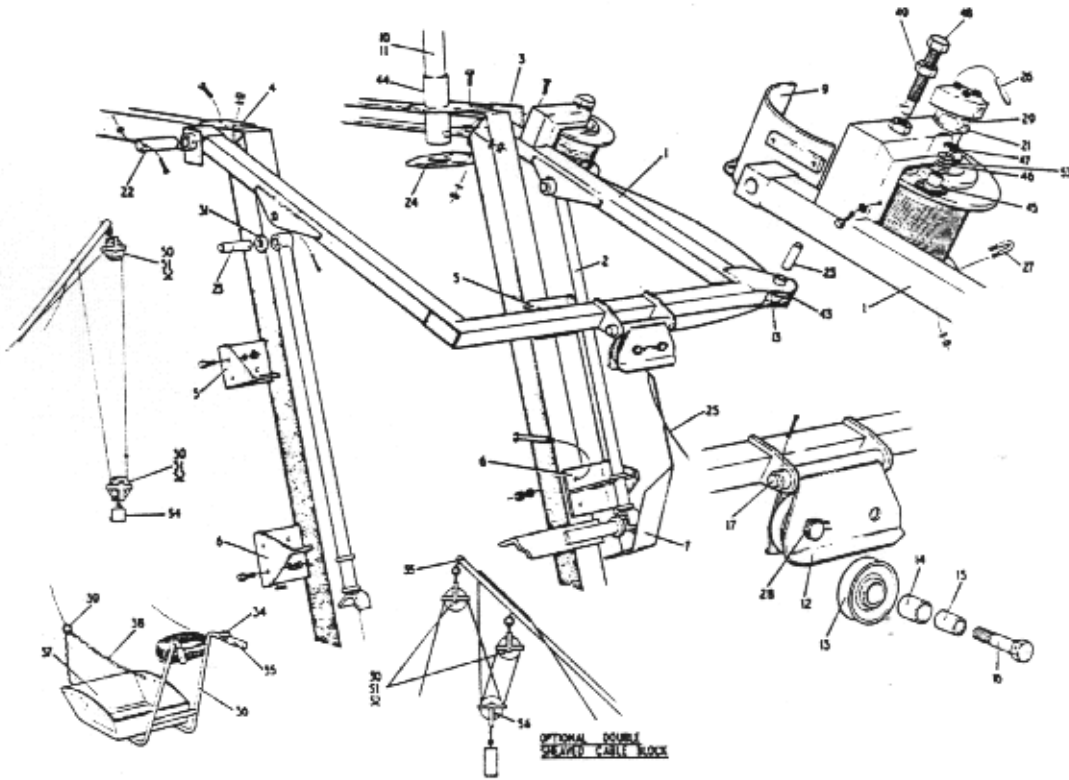

Ref N ^o	Description	Part N ^o	Qty
1	Assembly of Hydraulic Winch Mounting Bracket & Dragline Jig	555-1224	1
2	Jib Strut	555-1211	2
3	Jib Pivot Bracket (Engine Side) Complete with Csk Hd Screws Hex Nuts Spring Washers	555-1212 400-150810 330-350800 464-308000	1 1 1 1
4	Jib Pivot Bracket (Control Side) complete with Hex Hd Bolts Csk Hd Screws Hex Nuts Spring Washers	555-1213 460-350810 400-150810 330-350800 464-308000	1 2 1 3 3
5	Upper Stop Bracket complete with Hex Hd Bolts Hex Nuts Spring Washers	555-1209 460-350828 330-350800 464-308000	1RH 1 LH 4 4 4
6	Lower Stop Bracket complete with Hex Hd Bolts Hex Nuts Spring Washers	555-1210 460-350828 330-350800 464-308000	2 4 4 4
7	Guard complete with Hex Hd Bolts Hex Nut Spring Washers	555-1208 460-350606 330-350600 464-306000	1RH 1 LH 8 8 8
8	—	—	—
9	Rope Guard complete with Hex Hd. Setscrews Spring Washers	555-1228 418-250505 464-305000	1 4 4
10	Cable Mast Support complete with Hex Hd Bolt Hex Nut Spring Washer	555-1215 460-350824 330-350800 464-308000	1 1 1 1
11	Cable Support (Top End)	515-1344	1

DRAGLINE

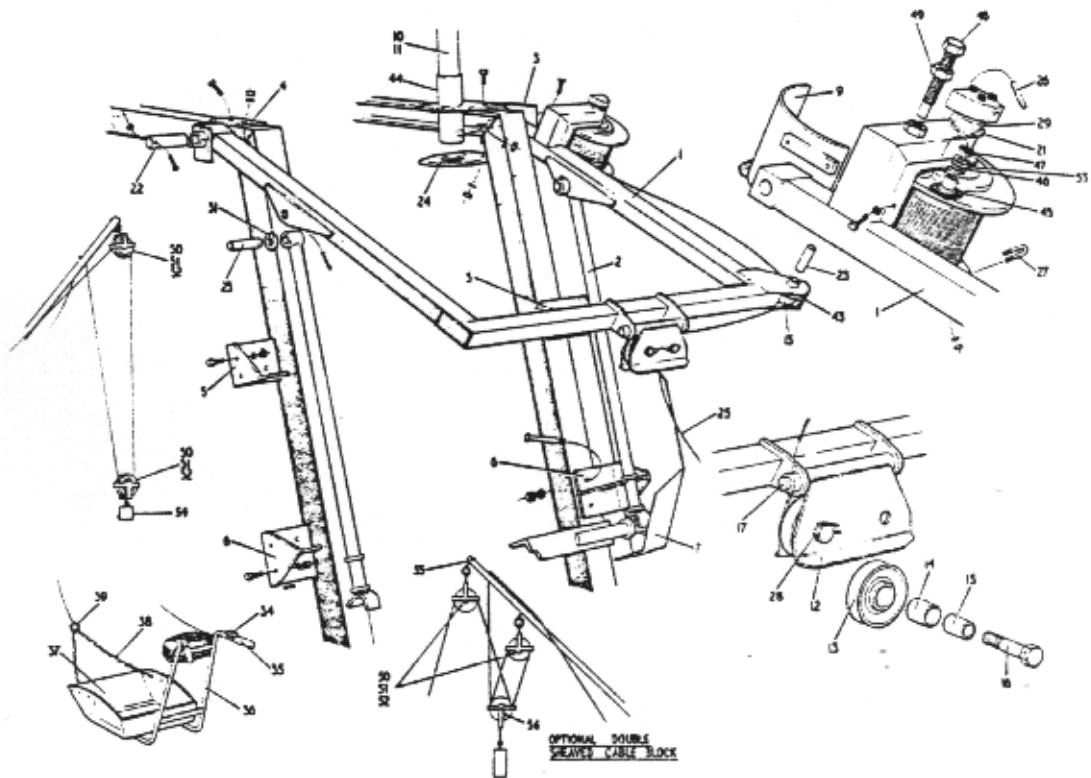

Ref N ^o	Description	Part N ^o	Qty
12	Pulley Bracket	555-1214	1
13	Side Pulley	879-1195	3
14	Glacier Bush	879-1200	2
15	Pulley Sleeve	555-1219	2
16	Special Bolt	555-1222	2
17	Pulley Bracket Pivot Pin complete with Split Pins	555-1220 353-306200	1 1
18	—	—	—
19	—	—	—
20	—	—	—
21	Tab Washer	555-1232	1
22	Jib Pivot Pin complete with Hex Hd Bolts Hex Binx Nuts	555-1231 460-350416 330-360400	2 2 2
23	Pin complete with Split Pins	555-1221 353-306200	3 3
24	Cable Mast Steady complete with Hex Hd Bolts Hex Nuts Spring Washers	555-1218 460-350810 330-350200 464-308000	1 2 2 2
25	Steel Wire Tope 75' 0" (22.86 metres)	477-502000	1 length
26	Parallel Key (Radius Ends)	304-213210	1
27	Bull Dog Grip (Less Saddle) complete with Spring Washers	132-205000 464-305000	1 2
28	Steel Locking Wire	477-350000	1 length
29	Backnut	240-112000	1
30	Locknut	330-551000	1
31	Bright Plain Washer	463-316000	2
32	Bright Plain Washer	463-308000	1
33	Rubber Gomet (Not Illustrated)	254-847000	1
34	Press Button Switch	208-866000	1
35	Handle Grips	264-705000	2

DRAGLINE

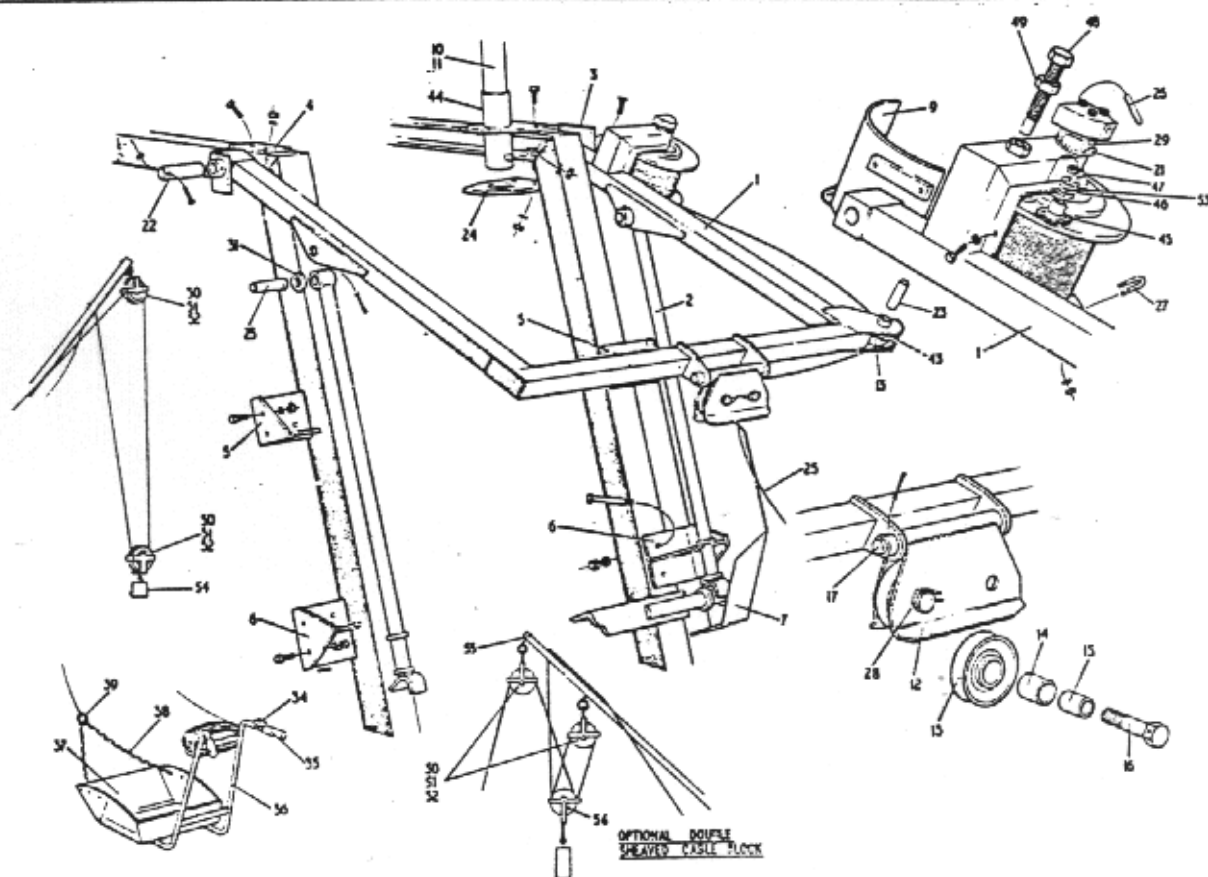

Ref No	Description	Part No	Qty
36	Handle	264-336000	1
37	Shovel Body	222-109000	1
38	Shovel Chain and Ring	135-902000	1
39	Shackle and Pin	353-855000	1
40	—	—	—
41	—	—	—
42	—	—	—
43	Dragline Pulley Spacer	555-1896	1
44	Cable Mast Support complete with	555-1876	1
	Hex Hd Bolts	460-350810	2
	Hex Nuts	330-350800	2
	Spring Washers	464-308000	2
45	Brake Pad	555-1924	1
46	Compression Spring	555-1926	1
47	Plain Washer	463-308000	1
48	Brake Adjusting Screw	555-1925	1
49	Hex Locknut	330-551000	1
50	Cable Control Block Bracket	929/A	2
51	Cable Control Block Pulley	930/B	2
52	Cable Control Block Spindle	929/B	2
53	Felt Washer	555-2012	1
54	Dragline Sheave Weight	555-2048	1
55	Mod. to Cable Support	555-2051	1
56	Double Sheave Cable Block	120-952000	1

DRAGLINE

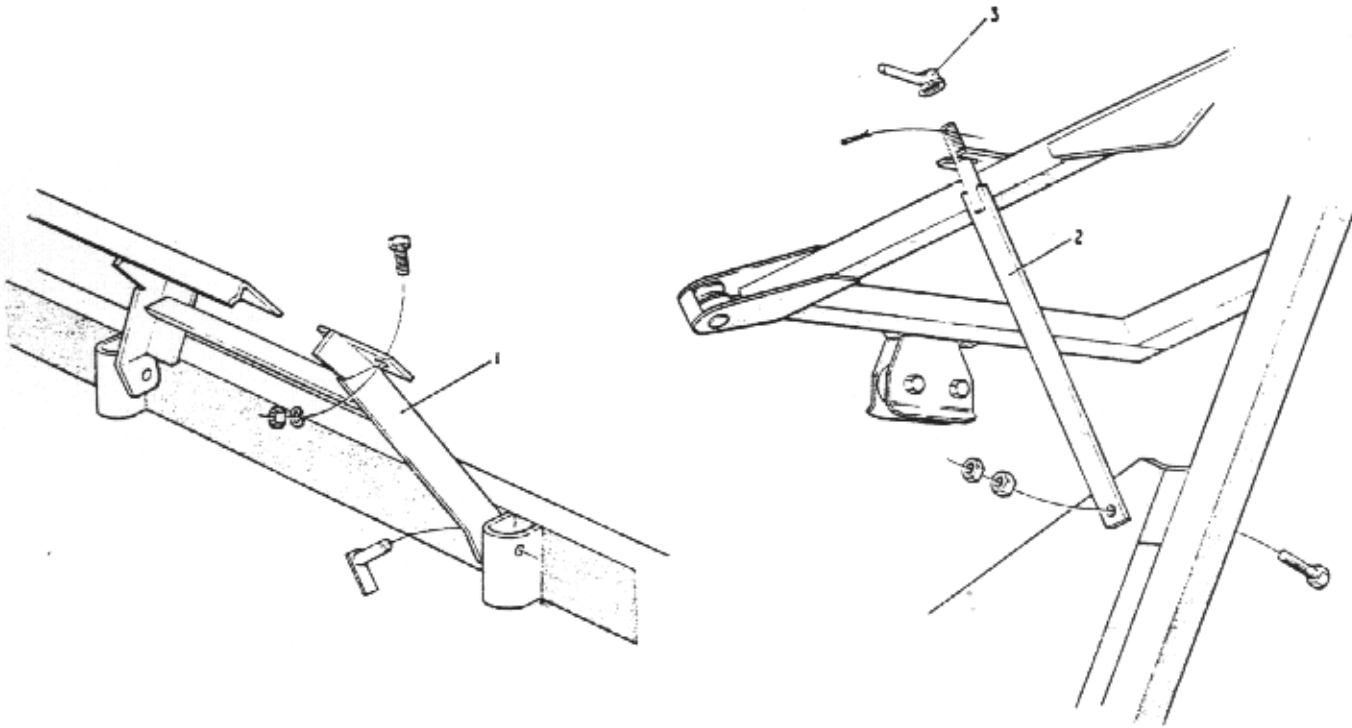

Ref N ^o	Description	Part N ^o	Qty
1	Hopper Anti-Bounce Bracket complete with Hex Hd Bolts Hex Nuts Spring Washers	555-1280	1
		460-510120	2
		331-851000	2
		464-310000	2
2	Tie Bar complete with Hex Hd Bolt Hex Nut Locknut Split Pin	555-1281	1
		460-506140	1
		331-850600	1
		330-256000	1
3	Locking Nut	353-303600	1
		555-1282	1

ANTI-BOUNCE

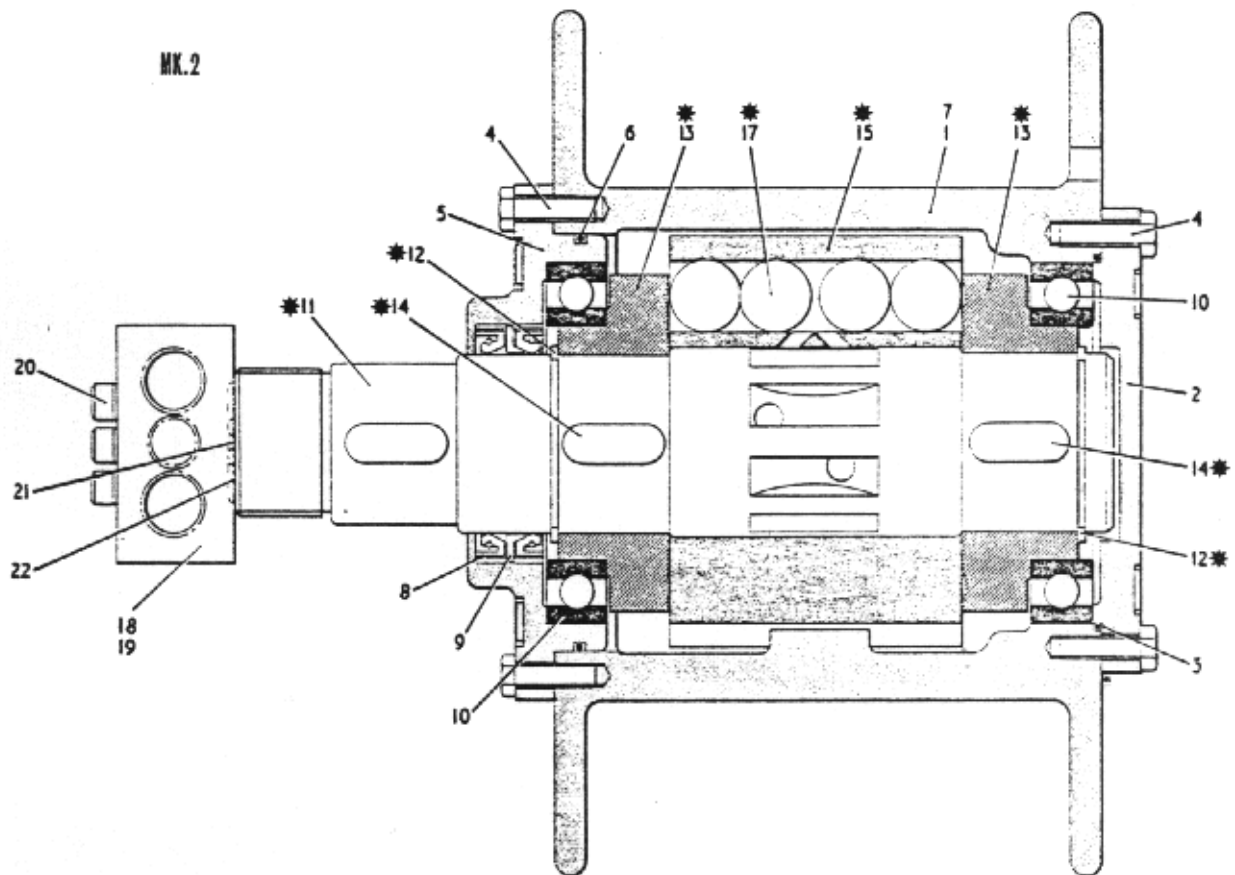

Ref No	Description	Part No	Qty	
1	Casing (Winch Only) Drilled to 555-1226	321/0147	480-10520	1
2	End Plate	321/0123	480-105001	1
3	'O' Ring	MH3-27	480-105002	1
4	Set Screw	MH3-26	480-105003	16
5	Bearing Housing	321/0124	480-105004	1
6	'O' Ring	MH3-26	480-105005	1
7	Casing (Hoist Only) Drilled to 555-1819	321/0147	480-105021	1
8	Oil Seal	MH3-7	480-105006	2
9	Back Up Ring	MH3-8	480-105007	1
10	Bearing No. 6015	MH3-19	480-105008	2
* 11	Shaft	321/0126	480-105009	1
* 12	External Circlip	MH3-23	480-105010	2
* 13	Cam	221/00900	480-105011	2
* 14	Cam Fixing Key	MH3-11	480-105012	2
* 15	Rotor	321/0122	480-105013	1
16				
* 17	Steel Ball	MH3-16	480-105014	36
18	Connection Block Single Rotation (Winch Only)	HS 2378	480-105015	1
19	Connection Block BI Rotational (Hoist Only)	MH3-1	480-105016	1
20	Socket Head Cap Screw	MH3-2	480-105017	3
21	'O' Ring	MH3-3	480-105018	1
22	'O' Ring	MH3-4	480-105019	2
23	Cartridge Assembly		480-105022	1

* Items marked thus may only be purchased as a complete cartridge assembly Ref. No. 23 owing to the close tolerance involved in the mating parts of the motor which precludes them from being interchangeable.

MARK II HYDRAULIC WINCH AND HOIST MECHANISM

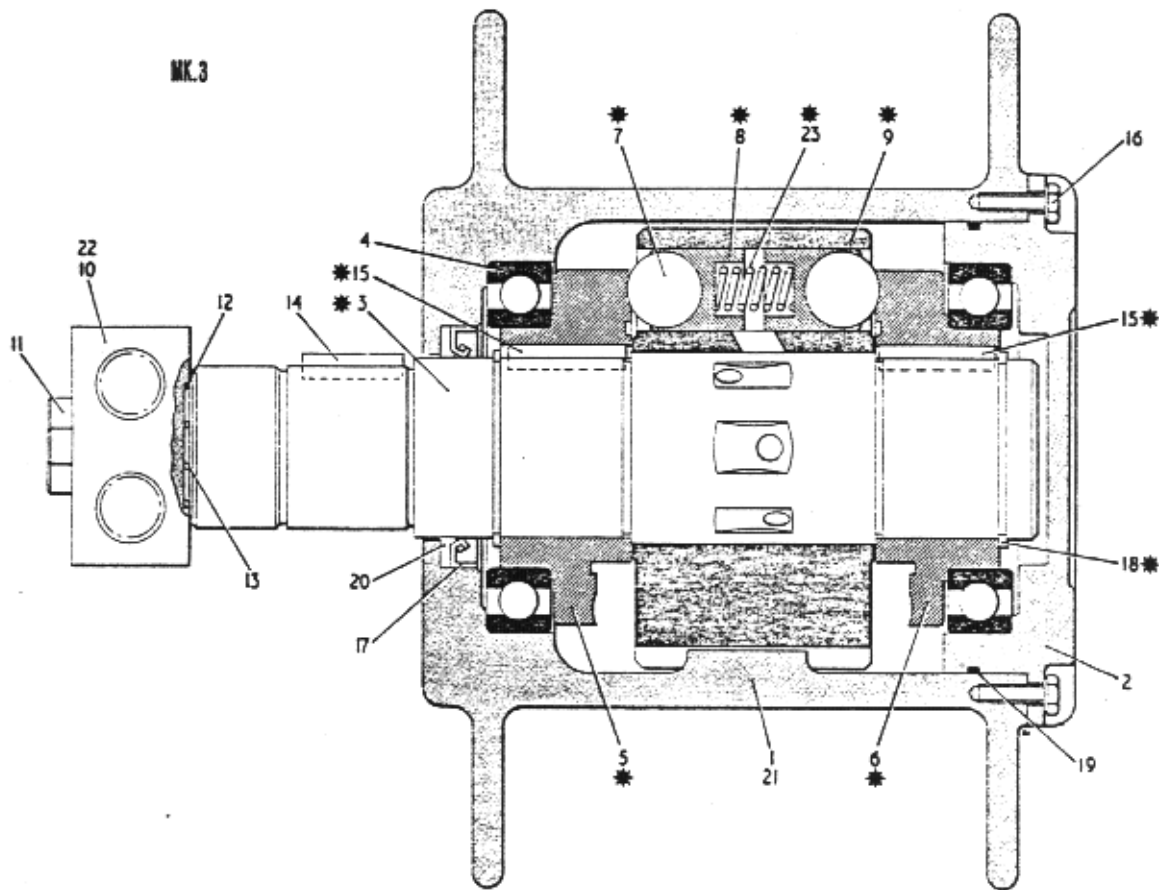

Ref N ^o	Description	Part N ^o	Qty	
1	Casing (Winch Only) Drilled to 555-1917	1410414	480-107021	1
2	Rear Cover	3410413	480-107001	1
* 3	Shaft	1410408	480-107002	1
4	Bearing	Ref. 6015	480-105008	2
* 5	Cam (Front)	SP 2670C	480-107004	1
* 6	Cam (Rear)	SP 2671C	480-107005	1
* 7	Ball	MH3-16	480-105014	18
* 8	Piston	SP 2672B	480-107007	18
* 9	Rotor	SP 2669C	480-107008	1
10	Connection Block Single Rotation (Winch Only)	HS 2378	480-105015	1
11	Socket Head Cap Screw	MH3-2	480-105017	3
12	'O' Ring	MH3-4	480-105019	2
13	'O' Ring	MH3-3	480-105018	1
14	Key	SP2674B	480-107013	1
* 15	Key	MH3-11	480-105012	2
16	Hex Head Bolts		480-107015	8
17	Rotary Shaft Seal	MH3-7	480-105006	1
* 18	Circlip	MH3-23	480-107017	2
19	'O' Ring	R 4537	480-107018	1
20	Back-Up Ring	MH3-8	480-107007	1
21	Casing (Hoist Only) Drilled to 555-1918	1410414	480-107022	1
22	Connection Block BI-Rotational (Hoist Only)	MH3-1	480-105016	1
* 23	Anti Cavitation Spring	SP 1545	480-107023	9
24	Cartridge Assembly		480-107024	1

* Items marked thus may only be purchased as a complete cartridge assembly Ref. No. 24 owing to the close tolerances involved in the mating parts of the motor which precludes them from being interchangeable.

MARK III HYDRAULIC WINCH AND HOIST MECHANISM

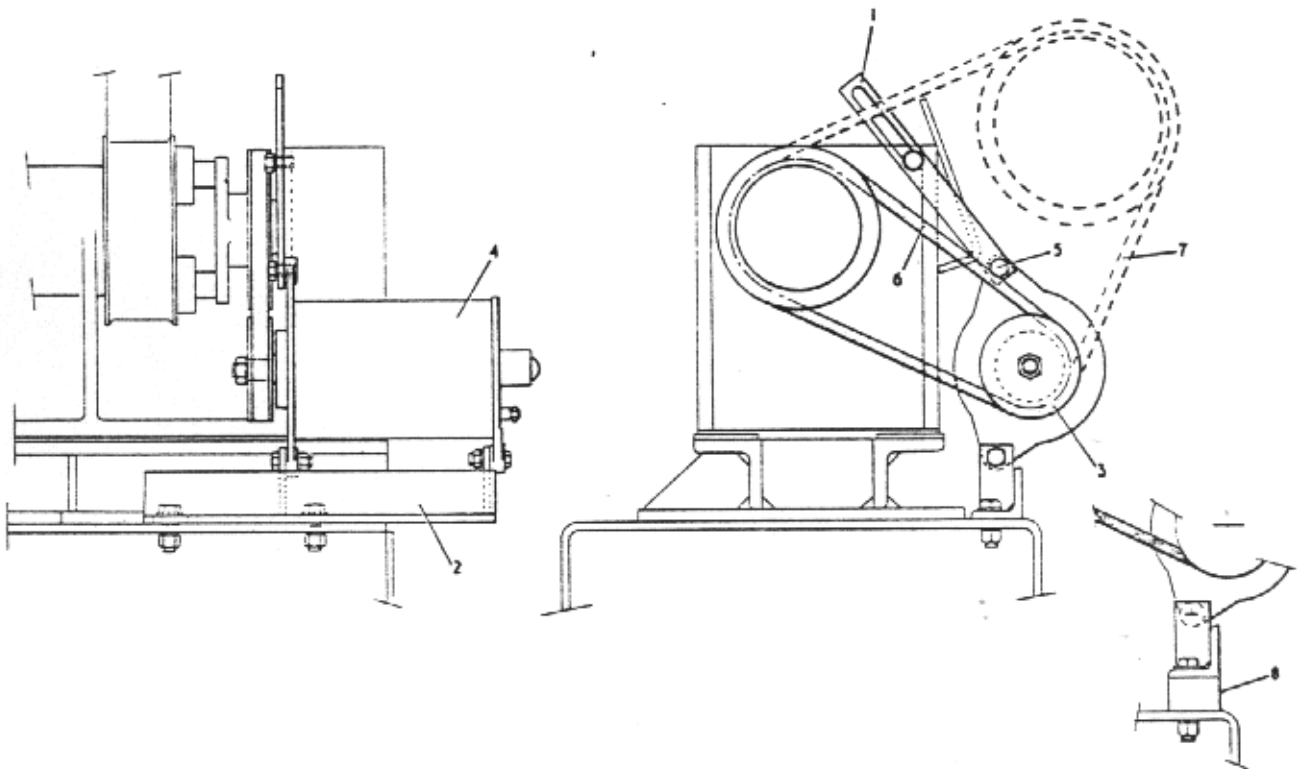

Ref N ^o	Description	Part N ^o	Qty	
1	Dynamo Adjuster complete with	555-1323	1	
		Hex Hd Setscrew	418-350505	1
		Spring Washer	464-305	1
		Plain Washer	463-305	1
2	Dynamo Support	555-1771	1	
		Hex Hd Bolt	460-350609	2
		Hex Nut	330-3506	2
		Spring Washer	464-306	2
		Plain Washer	463-306	2
3	Dynamo Pulley	555-1322	1	
4	Dynamo complete with	205-501	1	
		Hex Hd Bolt	460-350508	2
		Hex Nut	330-3505	2
		Spring Washers	464-305	2
5	Hex Hd Setscrew complete with	418-350505	1	
		Spring Washer	464-305	1
6	Vee Belt (With Dynamo only fitted)	397-227	1	
7	Vee Belt (With Dynamo & Aerator fitted)	397-238	1	
8	Dynamo Packer (Electric Drive Only) complete with	555-1919	1	
		Hex Hd Bolts	418-250617	2
		Hex Nuts	330-350600	2
		Spring Washers	464-306000	2
		Plain Washers	464-306000	2

DYNAMO DRIVE ASSEMBLY

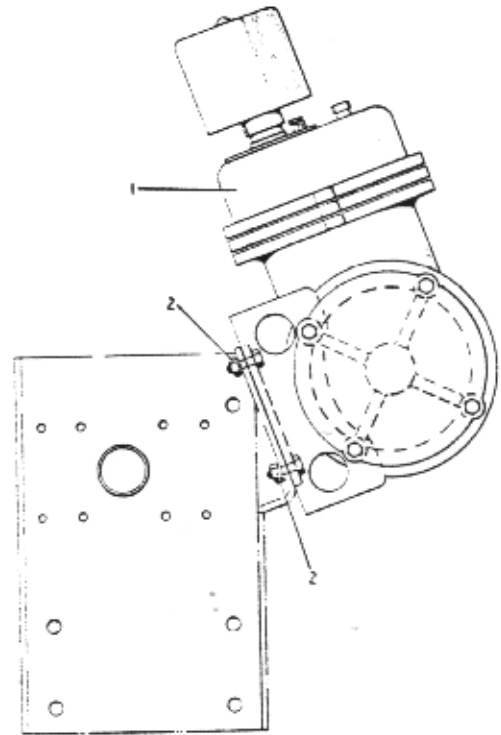
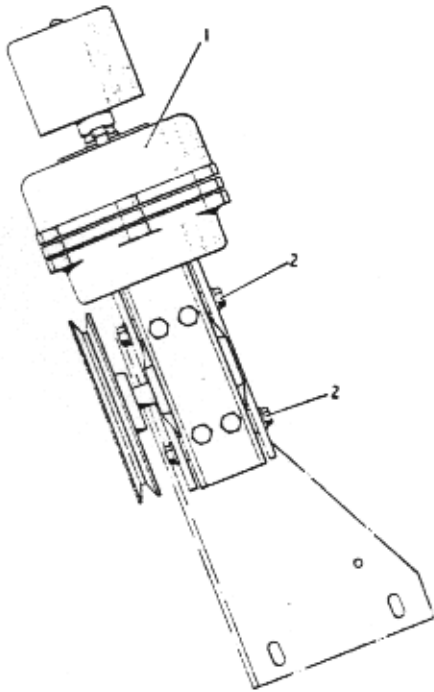

Ref N ^o	Description	Part N ^o	Qty
1	Compressor	136-252	1
2	Hex Hd Bolts complete with	418-250506	4
	Binx Nuts	330-3605	4
	Plain Washers	463-305	4

COMPRESSOR DRIVE—OPTIONAL

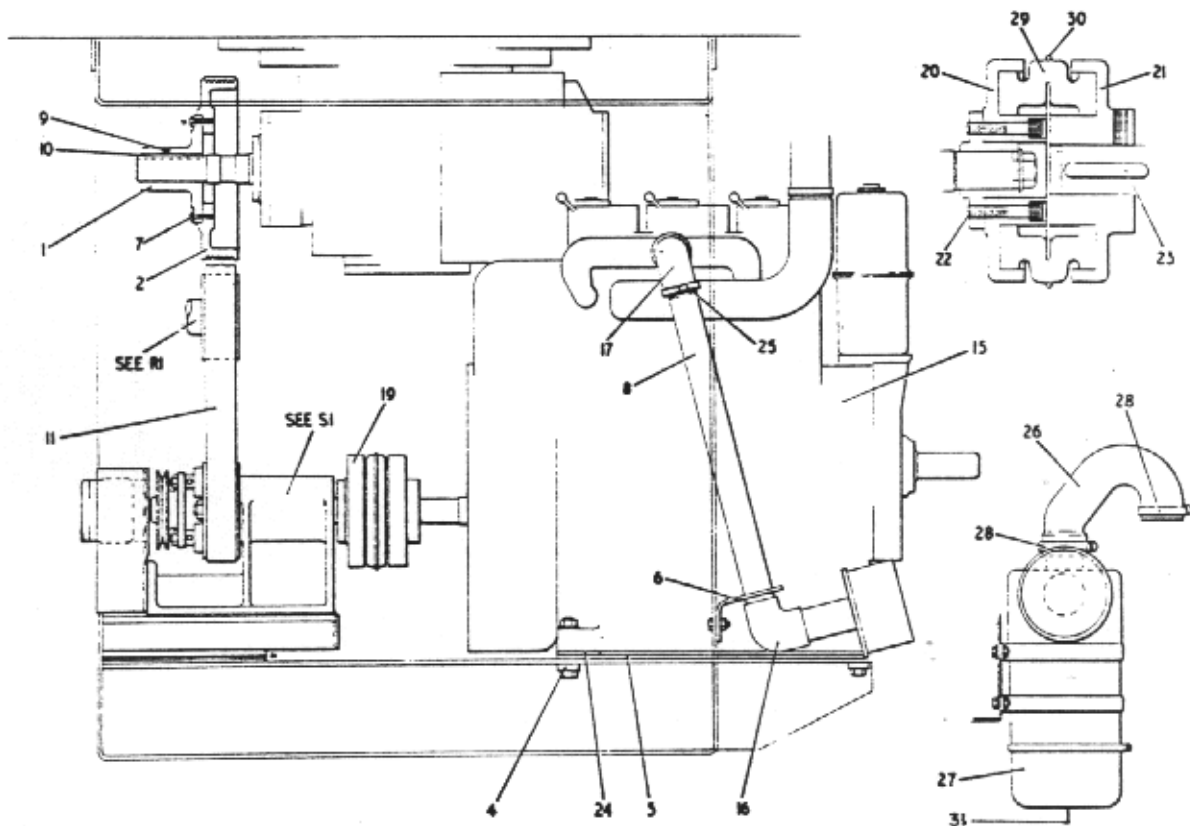

Ref No	Description	Part No	Qty
1	Drive Flange	555-1607	1
2	Drive Pulley	555-1608	1
3	—	—	—
4	Engine Bolt Retaining Bar	555-1405	2
5	Engine Packers	555-1856	1 set
6	Exhaust Pipe Clip complete with Hex Hd Bolts Binx Nuts Plain Washers	555-1429 460-350608 330-360600 463-306000	1 2 2 2
7	Special Bolt for Drive Flange complete with Locking Wire	555-1621 477-353000	6 1 Lgth
8	Exhaust Pipe	555-1428	1
9	Cone Pt. Socket Setscrew	403-560508	1
10	Parallel Key (Round Ends)	304-106240	1
11	Belt	12-414000	1
12	—	—	—
13	—	—	—
14	—	—	—
15	Lister SR3 Diesel Engine complete with Hex Hd Bolts (H.T.) Binx Nuts Plain Washers	460-350826 330-360800 463-308000	4 4 4
16	135° Elbow	240-758000	1
17	Male/Female Elbow	240-712000	1
18	Starting Handle Hook (Not Illustrated) complete with Hex Hd Bolts Hex Nuts Spring Washers	555-1407 460-505080 331-850500 464-305000	1 2 2 2
19	Assembly of Coupling Complete	555-1832	1
20	Coupling Half (Bearing Bracket Side)	555-1815	1
21	Coupling Half (Drive Side)	555-2032	1

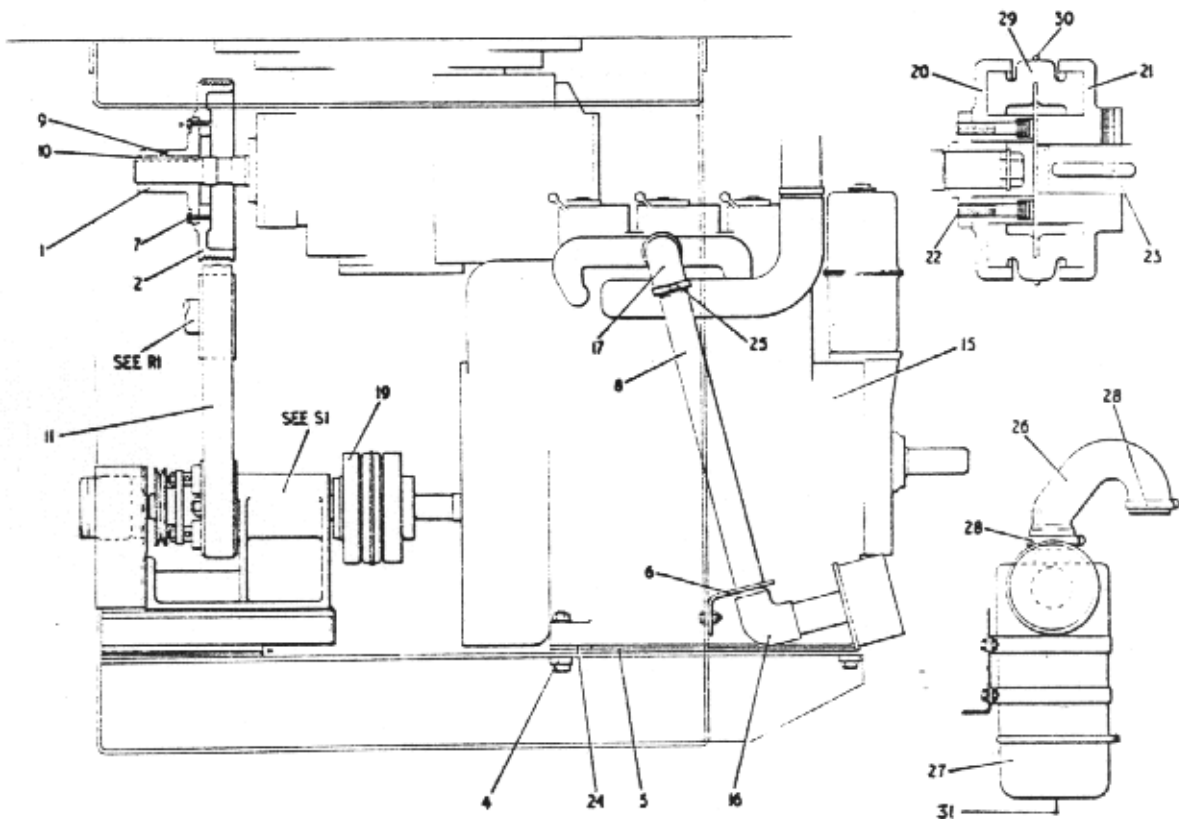

Ref N ^o	Description	Part N ^o	Qty
22	Skt. Hd. Capscrew	404-70628	4
23	Parallel Key (Round Ends)	304-106200	1
24	Engine Packers	555-1866	1 set
25	Backnut	240-112000	1
26	Moulded Rubber Inlet Pipe	555-1887	1
27	Air Cleaner complete with	220-237000	1
	Hex Hd Bolts	460-506060	4
	Hex Nuts	331-850600	4
	Spring Washers	464-306000	4
	Plain Washers	463-306000	4
28	Clip	132-103000	2
29	Rubber Centres	147-307002	1 pair
30	Wire Retaining Ring	147-307003	1
31	Split Pin	353-304800	1

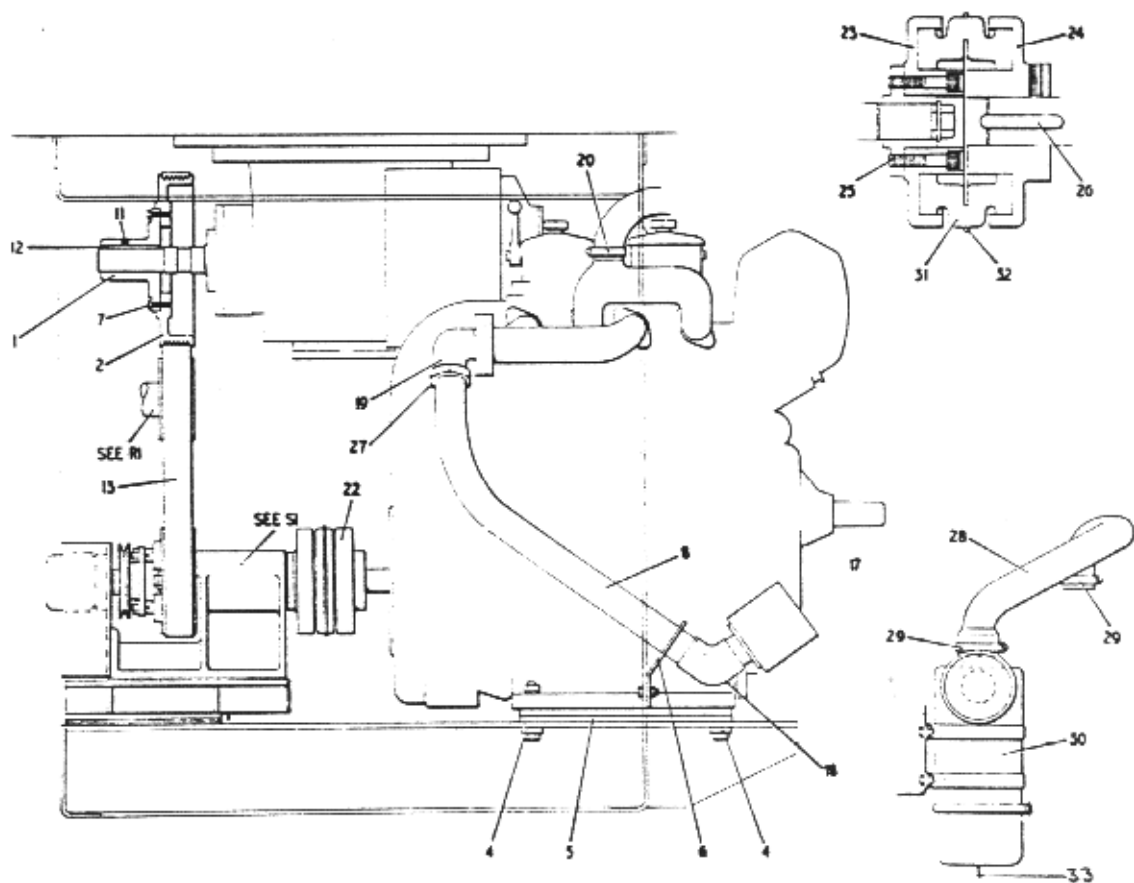

Ref N ^o	Description	Part N ^o	Qty
1	Drive Flange	555-1607	1
2	Drive Pulley	555-1608	1
3	—	—	—
4	Engine Bolt Retaining Bar	555-1430	2
5	Engine Packers	555-1441	1 set
6	Exhaust Pipe Clip complete with Hex Hd Bolt Binx Nut Plain Washers	555-1440 460-350608 330-360600 463-306000	1 2 2 2
7	Special Bolts for Drive Flange complete with Locking Wire	555-1621 477-353000	6 1 Lgth
8	Exhaust Pipe	555-1439	1
9	—	—	—
10	—	—	—
11	Cone Pt. Skt. Setscrew	403-560608	1
12	Parallel Key (Round Ends)	304-106240	1
13	Belt	122-414000	1
14	—	—	—
15	—	—	—
16	—	—	—
17	Petter P.H.2. Diesel Engine complete with Hex Hd Bolts (H.T.) Binx Nuts Plain Washers	460-350826 330-360800 463-308000	4 4 4
18	Equal Socket	241-912000	1
19	Male/Female Equal Elbow	240-712000	1
20	—	—	—
21	Starting Handle Hook (Not Illustrated) complete with Hex Hd Bolts Hex Nuts Spring Washers	555-1407 460-505080 331-850500 464-305000	1 2 2 2

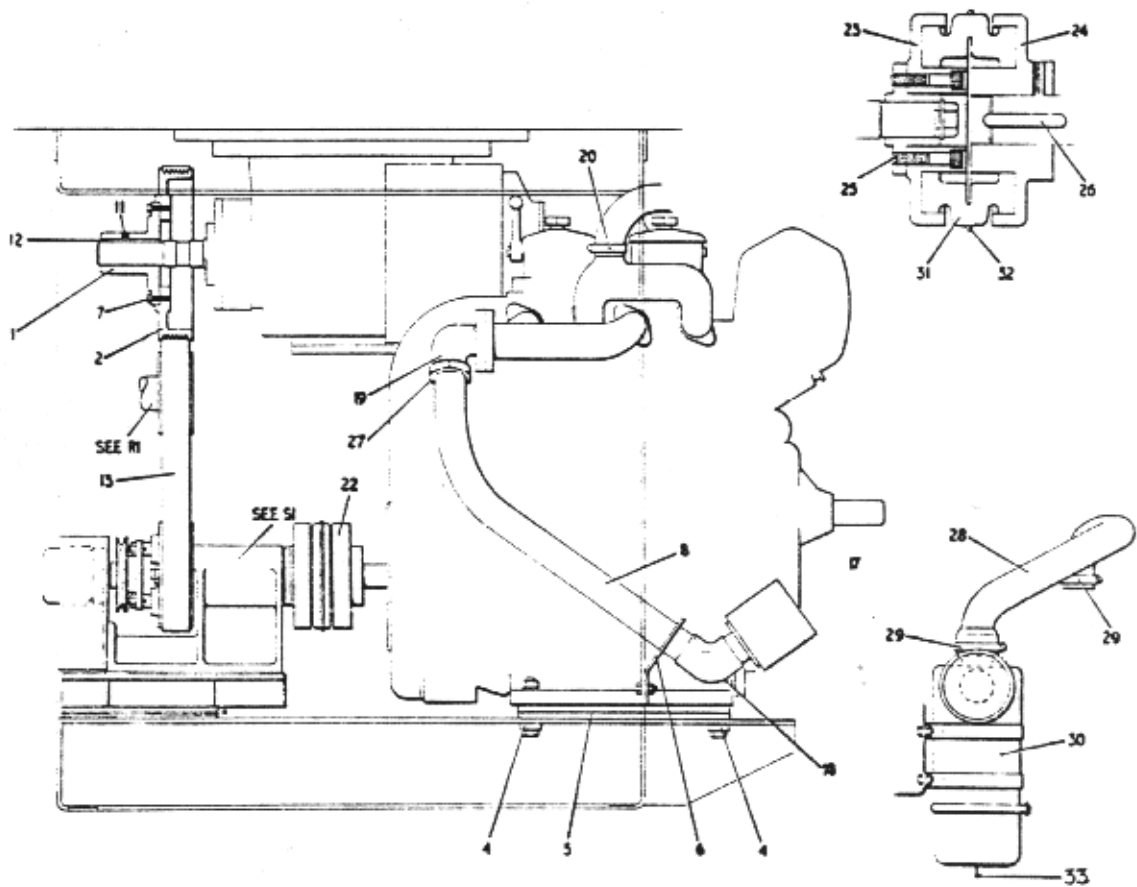

Ref N ^o	Description	Part N ^o	Qty
22	Assembly of Coupling Complete	555-1832	1
23	Coupling Half (Bearing Bracket Side)	555-1815	1
24	Coupling Half (Drive Side)	555-2032	1
25	Skt. Hd Capscrew	404-706280	4
26	Parallel Key (Round Ends)	304-106200	1
27	Backnut	240-112000	1
28	Moulded Rubber Inlet Pipe	555-1892	1
29	Clip	132-120040	2
30	Air Cleaner complete with Hex Hd Bolts Hex Nuts Spring Washers Plain Washers	220-229000 460-505050 331-850500 464-305000 463-305000	1 4 4 4 4
31	Rubber Centres	147-307002	1 pair
32	Wire Retaining Ring	147-307002	1
33	Split Pin	353-304800	1

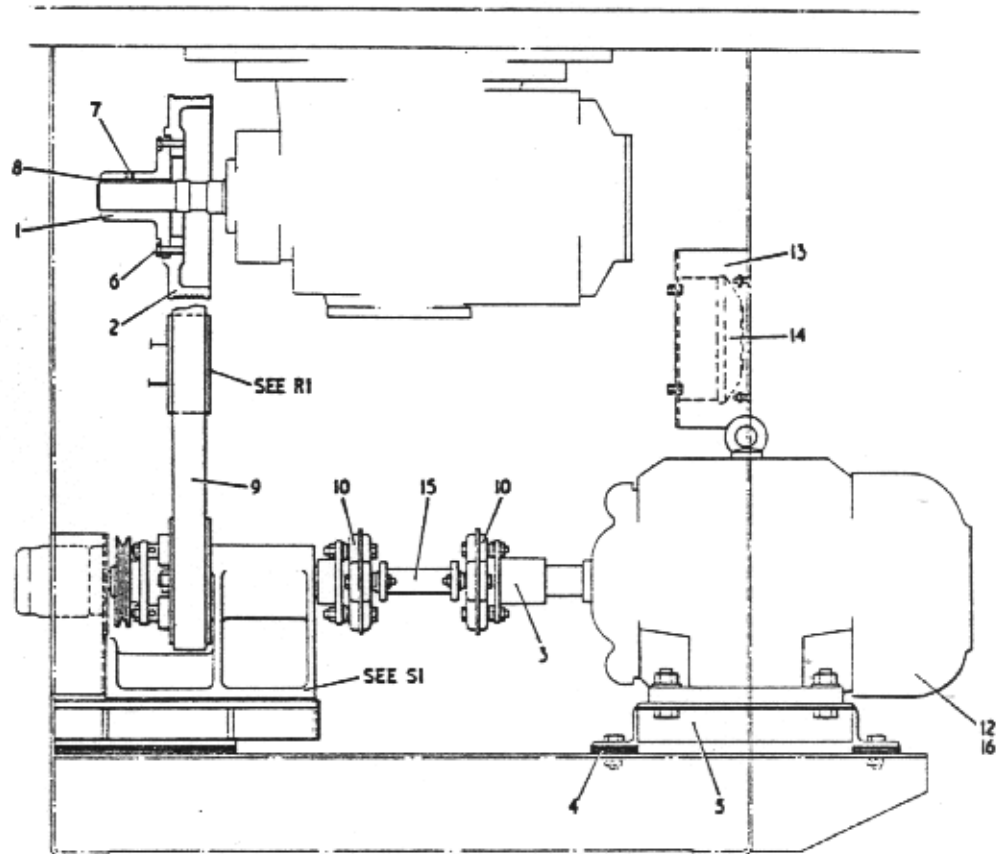

Ref N ^o	Description	Part N ^o	Qty
1	Drive Flange	555-1607	1
2	Driven Pulley	555-1608	1
3	Drive Flange	555-1455	1
4	Motor Mounting Packers	555-1626	1Set
5	Electric Motor Mounting complete with	555-1454	1
	Hex Hd Bolts (H.T)	460-350812	4
	Binx Nuts	330-3608	4
	Plain Washers	463-308	4
6	Special Bolt for Drive Flange complete with	555-1621	6
	Locking Wire	477-353	1Length
7	Cone Pt Socket Setscrew	403-560508	1
8	Parallel Key (Rd Ends)	304-10624	1
9	Belt	122-414	1
10	Coupling	130-955	2
11	Cone Pt Skt Setscrew	404-910506	1
12	Norco Electric Motor complete with	-	1
	Hex Hd Bolts (H.T)	460-350818	4
	Binx Nuts	330-3608	4
	Plain Washers	463-308	4
13	Starter Mounting Bracket complete with	555-1442	1
	Csk Hd Screws	400-150608	4
	Hex Nuts	330-3506	4
	Spring Washers	464-306	4
14	Starter complete with	208-301500	1
	Hex Hd Bolts	460-350406	4
	Hex Nuts	330-3504	4
	Spring Washers	464-304	4
15	Connecting Shaft	555-1426	1
16	Adaptor	555-1877	1 set
17	Transparent Protective Cap	205-626000	2

NORCO ELECTRIC

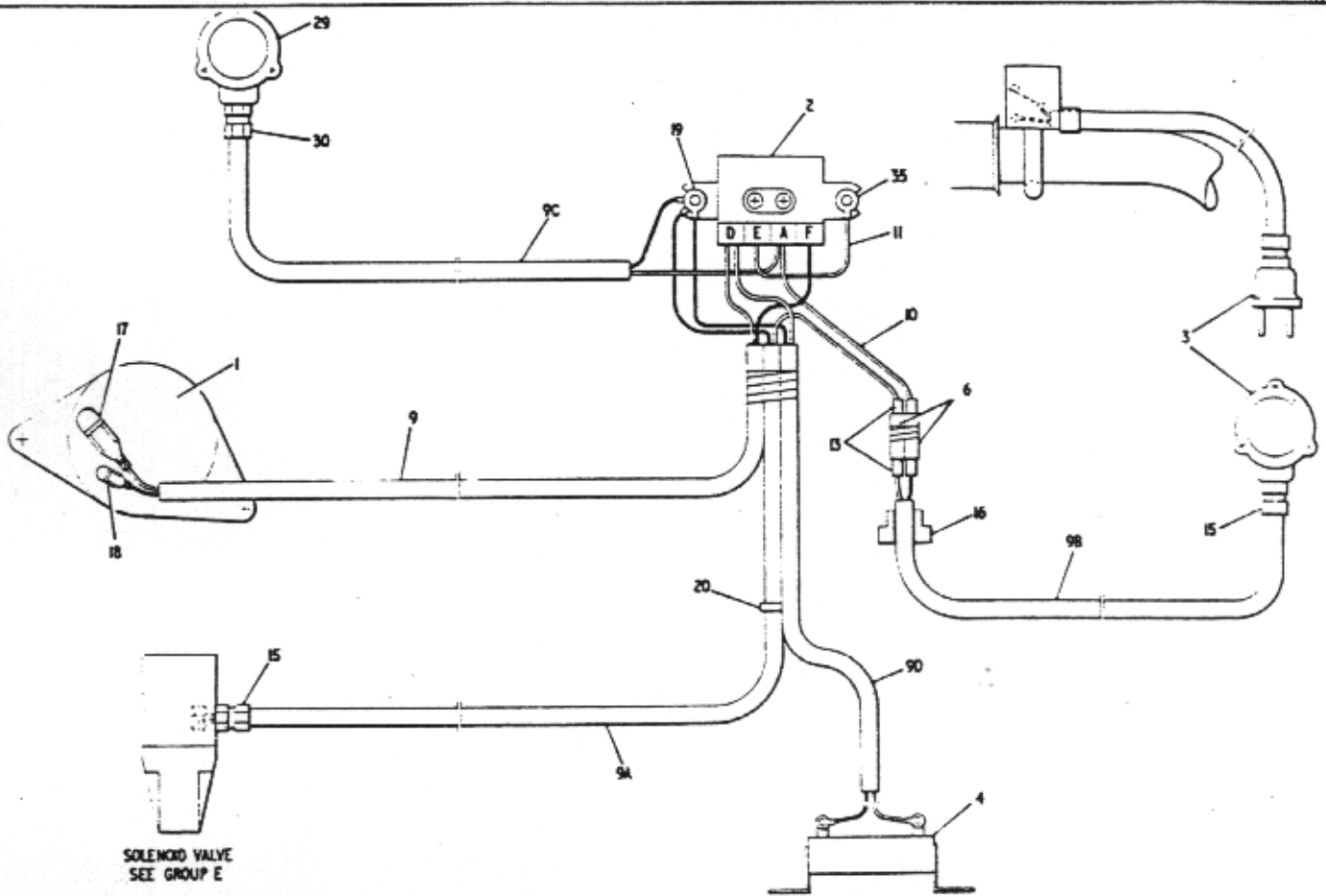

Ref N ^o	Description	Part N ^o	Qty
1	Generator	205-402000	1
2	Regulator	383-208000	1
3	Plug and Socket	205-323000	1
4	Resistor	207-652000	1
5	—	—	—
6	Connectors	147-604000	2
7	—	—	—
8	—	—	—
9	Twin Core P.V.C. Cable Brown and Blue Inner Cores:—		1
	2.9 metres long Generator to Regulator	144-747000	1
9a	1.5 metres long Solenoid to Earth and Connector	144-747000	1
9b	2.13 metres long Connectors to Shovel Socket	144-747000	1
9c	1.5 metres long Regulator and Earth to Optional Socket	144-747000	1
9d	3.56 metres long Resistor to Regulator	144-747000	1
10	Single Core 32/0.20 Red P.V.C. Cable 127mm long from Regulator to Connector	144-748000	1
11	Single Core 32/0.20 Green P.V.C. Cable 127mm long from Regulator to Earth	144-749000	1
12	—	—	—
13	Nipples	333-354000	4
14	—	—	—
15	3/8in. Brass Cable Gland	250-103000	2
16	1/8in. Male Brass Bush	131-405000	1
17	Terminal with Insulator	191-917000	1
18	Terminal with Insulator	191-918000	1
19	Terminal OBA	191-912000	3
20	Clips	132-821000	14
21	Twin Core Cable Red and Black Inner Cores 23 metres long	144-734000	1
29	Plug and Socket	205-323000	1
30	3/8in. Brass Cable Gland		1
35	Terminal	191-912000	1

WIRING DIAGRAM

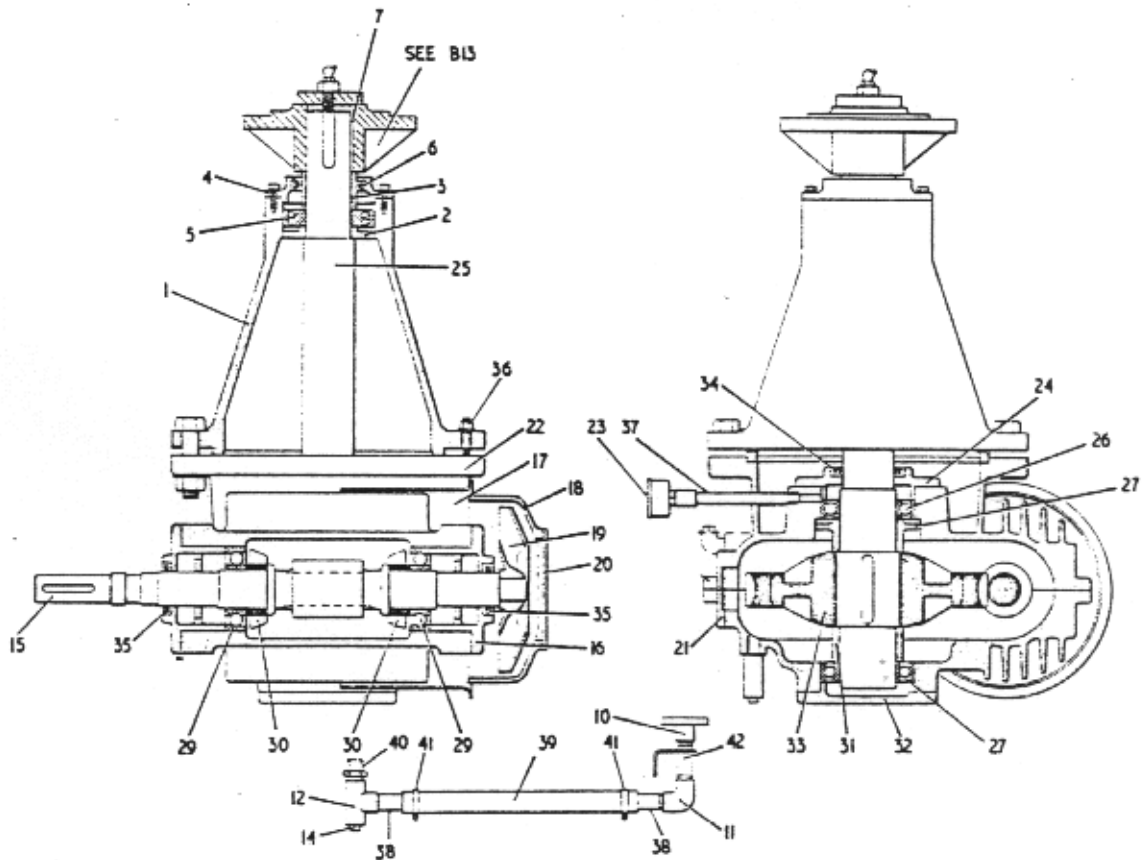

Ref No	Description	Part No	Qty
1	Reduction Shaft Housing complete with Hex Hd Bright Bolts Binx Nuts Plain Washers	555-1575 460-351428 330-361400 463-314000	1 4 4 4
2	Short Spacer	512-1035	1
3	Long Spacer	555-1595	1
4	Oil Seal Housing complete with Hex Hd Setscrews Spring Washers	555-1577 418-350607 464-306000	1 4 4
5	Ball Bearing	104-120000	1
6	Oil Seal	417-781000	1
7	Parallel Key (Round Ends)	304-110248	1
8	-	-	-
9	-	-	-
10	Oil Filler Cap	555-1599	1
11	Elbow	241-106000	1
12	Tee	242-206000	1
13	-	-	-
14	Plug	241-706000	1
15	Wormshaft L.H. (c 37039)	- 254109021	1
16	Wormshaft Open Cover (B 21607)	- 254109006	2
17	Deflector (C 14020)	-	1
18	Fan Cowl (C 14019)	- 254109012	1
19	Fan (B 7604)	254117013 254109021	1
20	Wire Mesh Guard	-	1
21	Inspection Cover (B 37043)	254109024	1
22	Gear Case (F 35284)	254109025	1
23	No. 6 Grease Stauffer	-	1
24	S.S. Shaft Open Cover (B 14782)	254109005	1
25	Slow Speed Shaft (C 37022)	254109026	1
26	S.S. Shaft Ball Bearing (175 ACD)	254109018	2

WORM REDUCTION UNIT

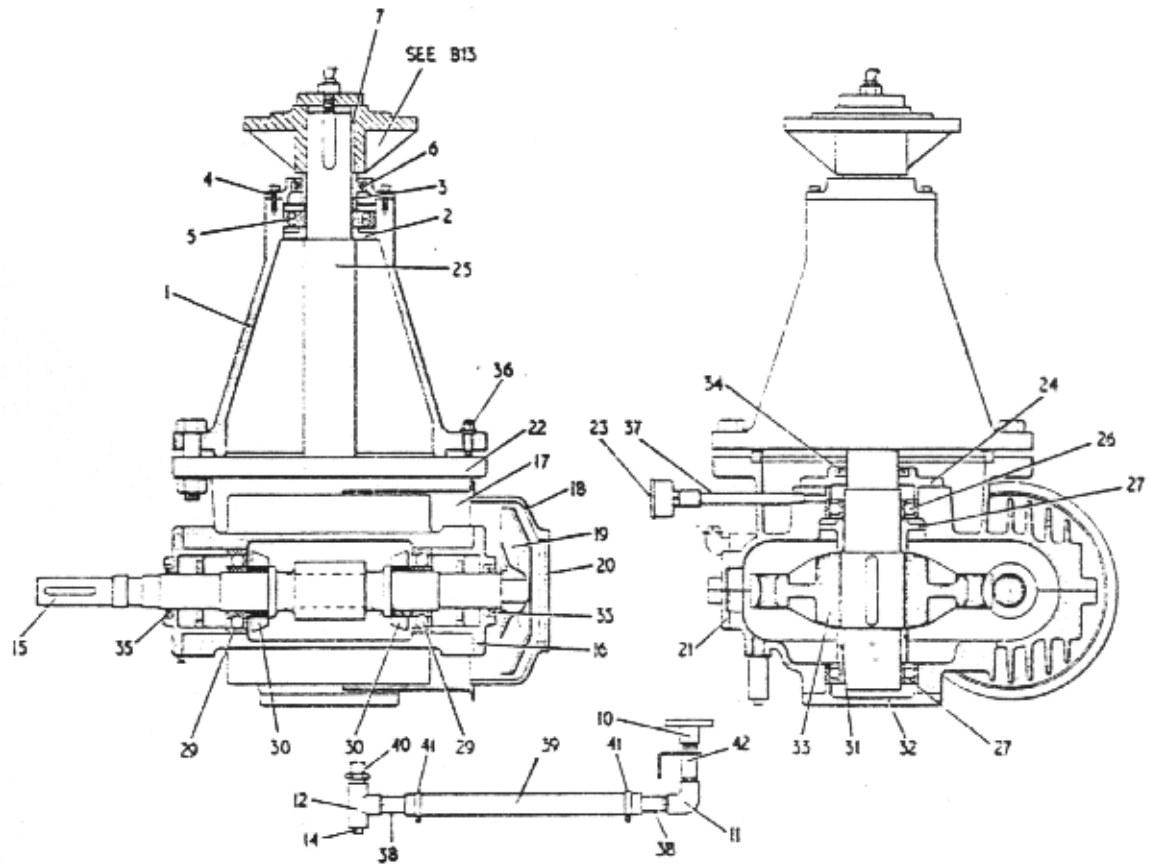

Ref N ^o	Description	Part N ^o	Qty
27	Grease Retaining Plate (B 35283)	254109020	1
28	Narrow Spacer (B 4808)	254109022	1
29	Double Purpose Bearings MS (15 ACD)	254109019	2
30	Oil Flinger (B 4814)	254109004	2
31	Wide Spacer (B 4809)	254109002	1
32	S.S. Shaft Blank (B 32553)	254109011	1
33	Worm Wheel (B 37040) (30 TEETH)	254109023	1
34	S.S. Shaft (400228)	254109015	1
35	Wormshaft Oil Seal (275124) W 27517550	417128440	2
36	Studs complete with	411-905120	2
	Hex Nuts	331-850500	2
	Plain Washers	463-305000	2
37	Greaser Extension Pipe	555-1898	1
38	Extension Piece	555-1971	2
39	Clear P.V.C. Tube	260-816012	1
40	Equal Hexagon Nipple	243-906000	1
41	Clips	132-101000	2
42	Filler Tube complete with	555-1970	1
	Hex Hd Bolts	460-505060	2
	Hex Nuts	331-850500	2
	Spring Washers	464-305000	2

WORM REDUCTION UNIT

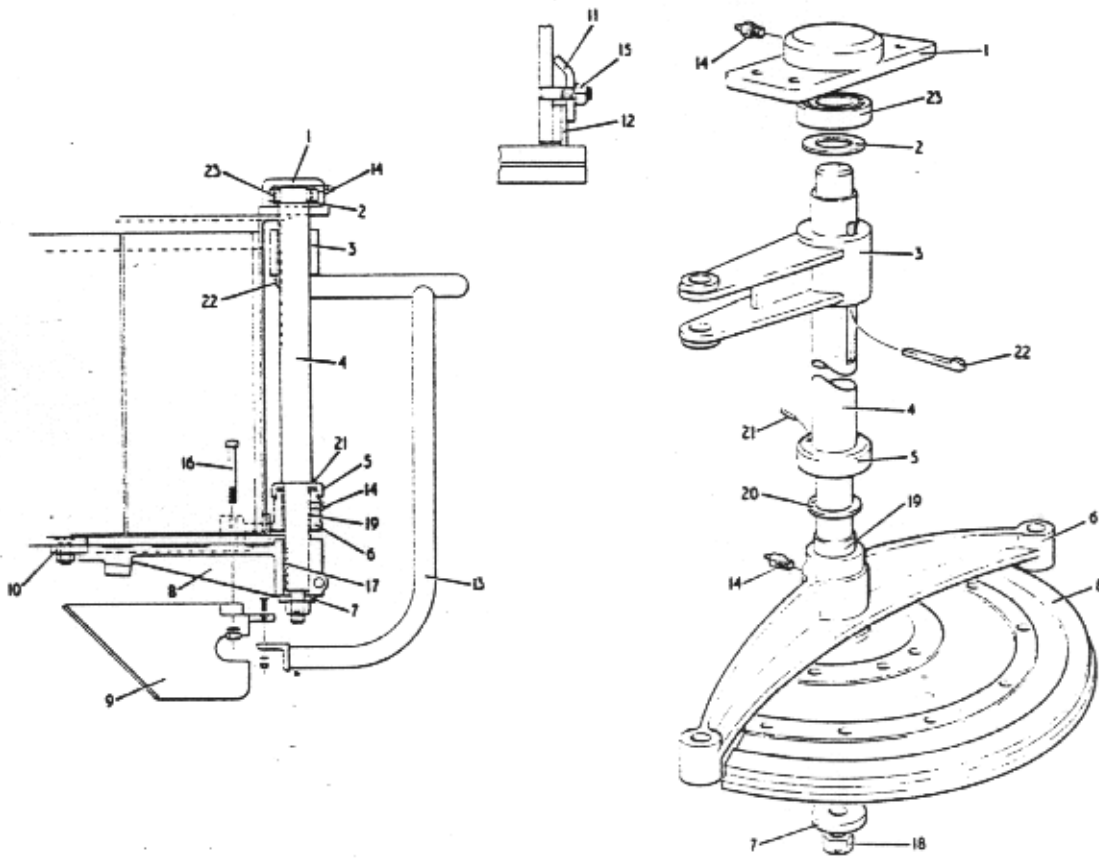

Ref N ^o	Description	Part N ^o	Qty
1	Bearing Bracket complete with	555-1549	1
1	Hex Hd Brightbolts H.T.	460-350816	2
	Hex Hd Bright Bolt H.T.	460-350814	2
	Binx Nuts	330-3608	4
	Plain Washers	463-308	4
2	Thrust Washer	512-1046	1
3	Ram Piston Bracket (Power Door only)	555-1565	1
4	Door Operating Shaft	555-1551	1
5	Door Operating Shaft Collar	555-1554	1
6	Lower Steady for Shaft	555-1548	1
7	Washer	512-1047	1
8	Discharge Door complete with	555-1547	1
	Hex Hd Bolt	460-350828	1
	Binx Nut	330-3608	1
	Plain Washer	463-308	1
9	Chute	555-1553	1
10	Discharge Door Sealing Ring	555-1550	1
11	Sealing Strip Clamp	512-1041	4
12	Door Sealing Strip	555-1555	1
13	Door Guard complete with	555-1552	1
	Hex Hd Bolts	460-350810	2
	Hex Nuts	330-3508	2
	Spring Washers	464-308	2

DISCHARGE DOOR (HAND & POWER)

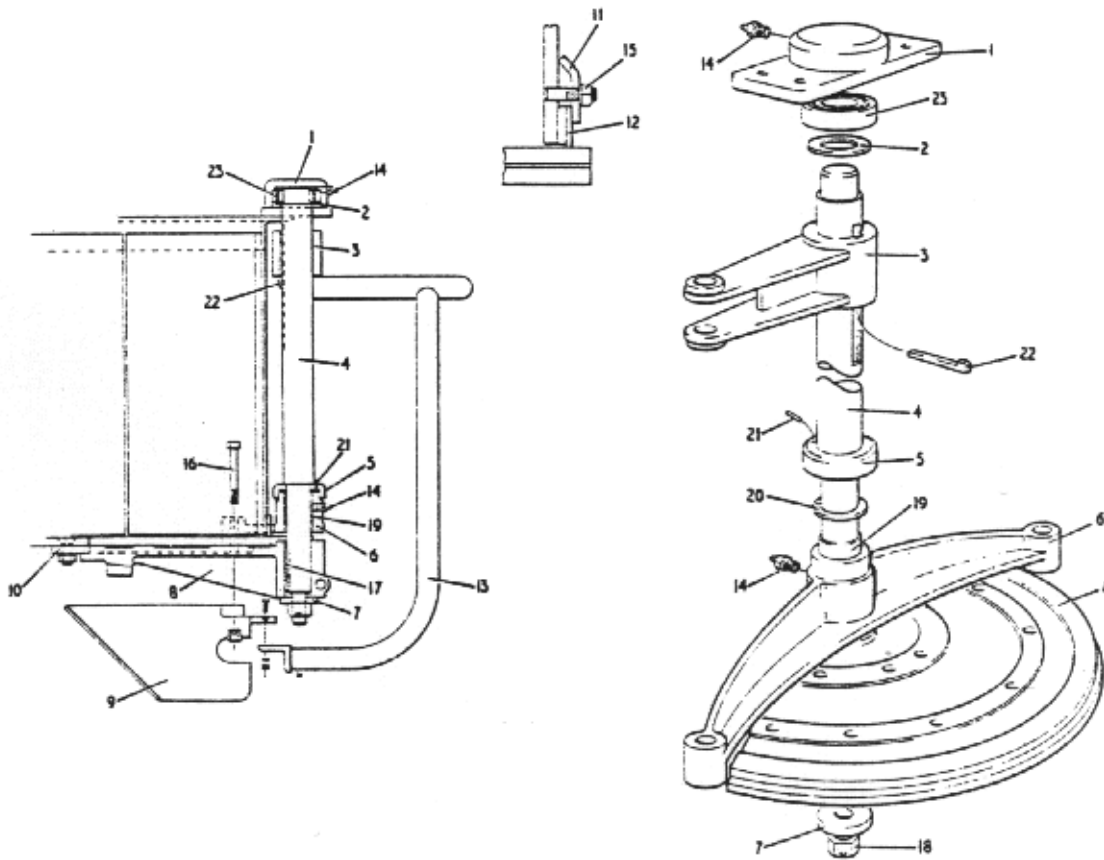

Ref N ^o	Description	Part N ^o	Qty
14	Straight Nipple	241-501	2
15	Hex Nuts complete with	331-8506	4
	Spring Washers	464-306	4
16	Hex Hd Bolts Bright complete with	460-351032	2
	Binx Nut	330-3610	2
	Plain Washers	463-310	2
17	Parallel Key (Radius Ends)	304-10622	1
18	Binx Nut	330-3612	1
19	Bush	112-8003	1
20	Thrust Washer	464-702	1
21	Hardened Steel Dowel	352-1538	1
22	Gib Head Key (Power Door only)	300-11626	1
23	Ball Bearing	104-112	1
24	Csk Hd Setscrews complete with	400-150810	2
	Hex Nut	330-3508	2
	Spring Washer	464-308	2

DISCHARGE DOOR (HAND & POWER)

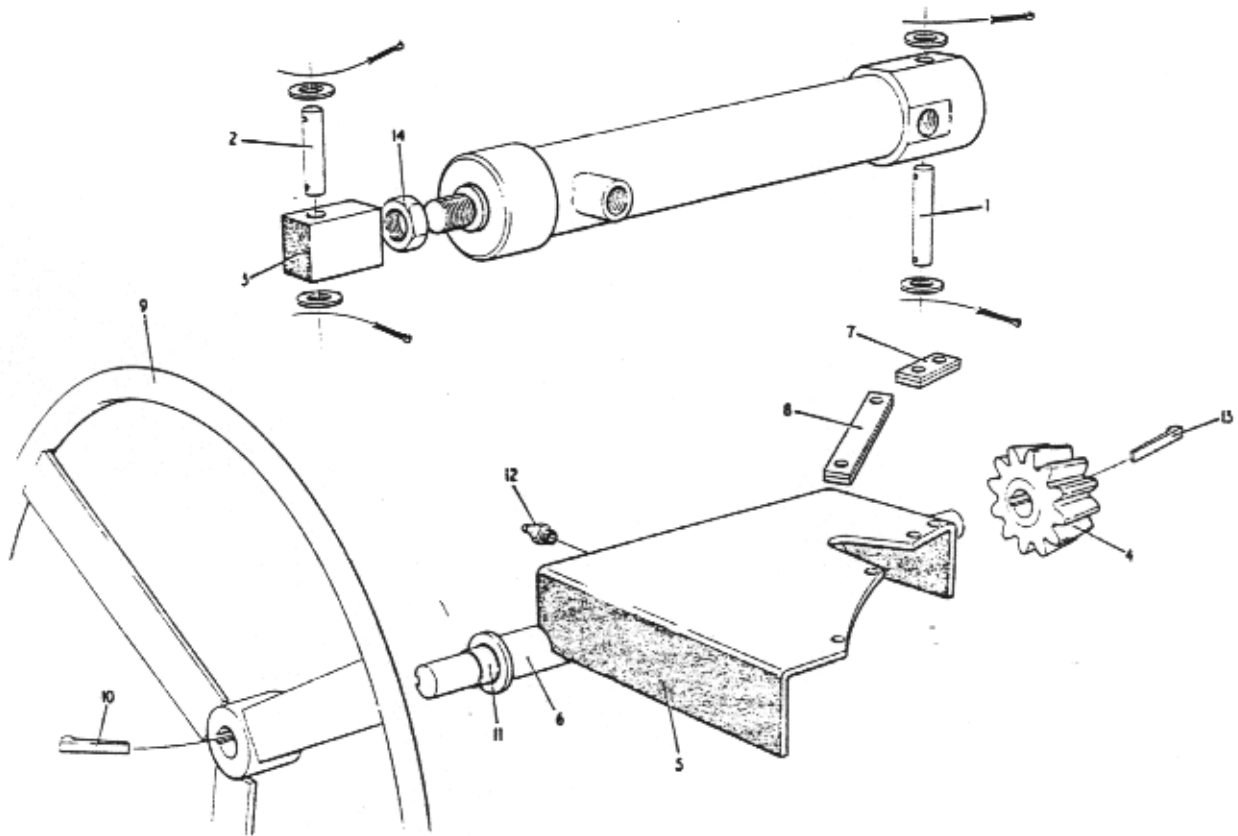

Ref N ^o	Description	Part N ^o	Qty
1	Ram Cylinder Bracket Pin (Power Door Only) complete with Bright Plainwashers Split Pin	555-1567 463-312 353-30510	1 2 2
2	Ram Piston Retaining Pin (Power Door only) complete with Bright Plainwashers Split Pin	555-1568 463-312 353-30510	1 2 2
3	Endpiece (Power Door only)	555-1566	1
4	Bevel Pinion (12 Teeth) (Hand Door only)	555-1557	1
5	Pinion Shaft Bracket (Hand Door only) complete with Hex Nuts Spring Washers	555-1559 330-3508 464-308	1 4 4
6	Pinion Shaft (Hand Door only)	555-1562	1
7	Packer Small (Hand Door only)	555-1564	2
8	Packer Large (Hand Door only)	555-1563	2
9	Manual Door Opening Handle (Hand Door only)	555-1558	1
10	Gib Head Key (Hand Door only)	300-20418	1
11	Bush (Hand Door only)	112-837	2
12	Straight Nipple (Hand Door only)	241-501	1
13	Gib Head Key (Hand Door only)	300-20414	1
14	Locknut (Power Door only)	331-216	1

DISCHARGE DOOR OPERATION (HAND & POWER)

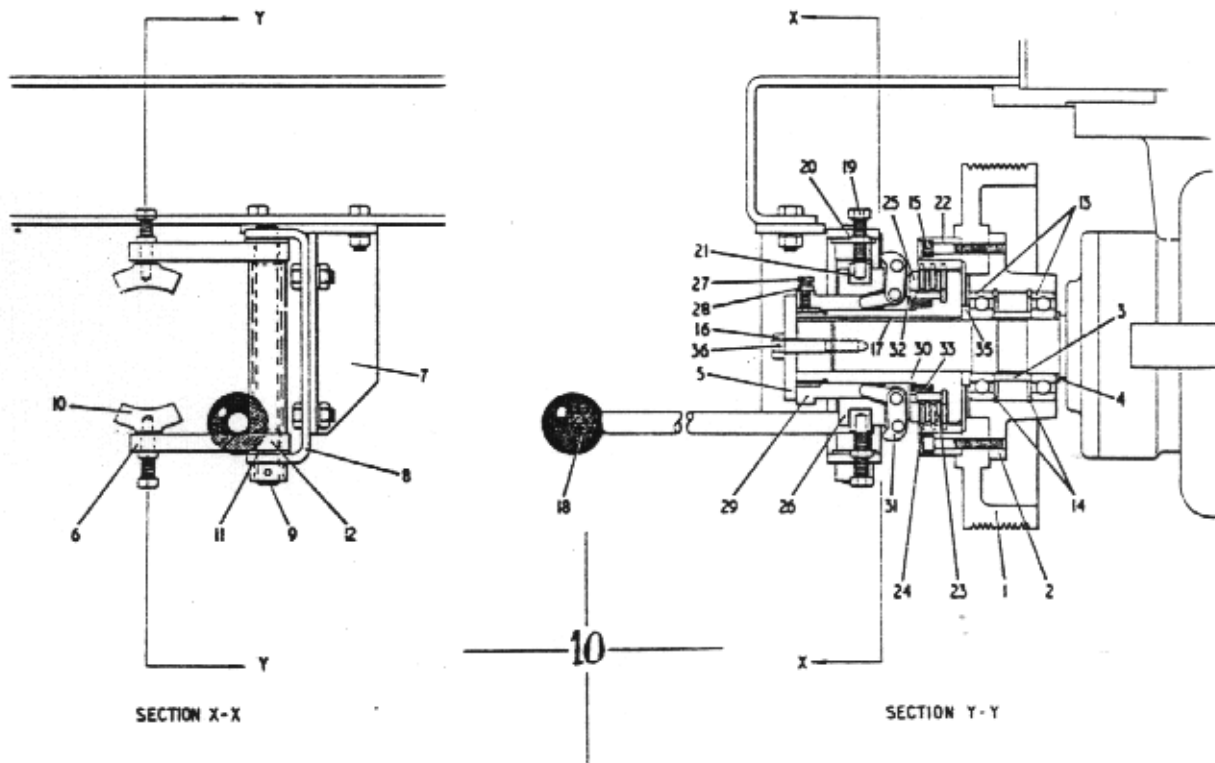

Ref No	Description	Part No	Qty
1	Driven Pulley	555-1628	1
2	Clutch Drive Pulley Spigot	555-1629	1
3	Clutch Bearing Spacer	512-1211	1
4	Clutch Bearing Packer	512-1210	1
5	Clutch Shaft Cap	512-1214	1
6	Clutch Operating Arm	555-1630	1
7	Clutch Operating Support Bracket complete with	555-1632	
	Hex Hd Bolt	460-350608	4
	Hex Nut	330-3506	4
	Spring Washer	464-306	4
8	Clutch Operating Arm Swivel Bracket	555-1631	1
9	Clutch Operating Pin complete with	555-1633	1
	Split Pin	353-30512	1
10	Clutch Assembly	130-930	1
11	Bright Plain Washers	463-310	2
12	Bush	114-622	2
13	Ball Bearing	109-44001	2
14	Circlip	142-319	2
15	Skt Hd Capscrew	404-750532	6
16	Retaining Bolt complete with	555-1848	2
	Spring Washer	464-306	1
17	Parallel Key (Rd Ends)	304-10624	1
18	Plastic Knob	307-120	1
19	Tappet Screws — 3269	130-9300①	2
20	Tappet Nuts — 3508	130-9300②	2
21	Tappet Brasses — 20187	130-9300③	2
22	External — 21644	130-9300④	1
23	Spacer Plates — 5673	130-9300⑤	2

CLUTCH

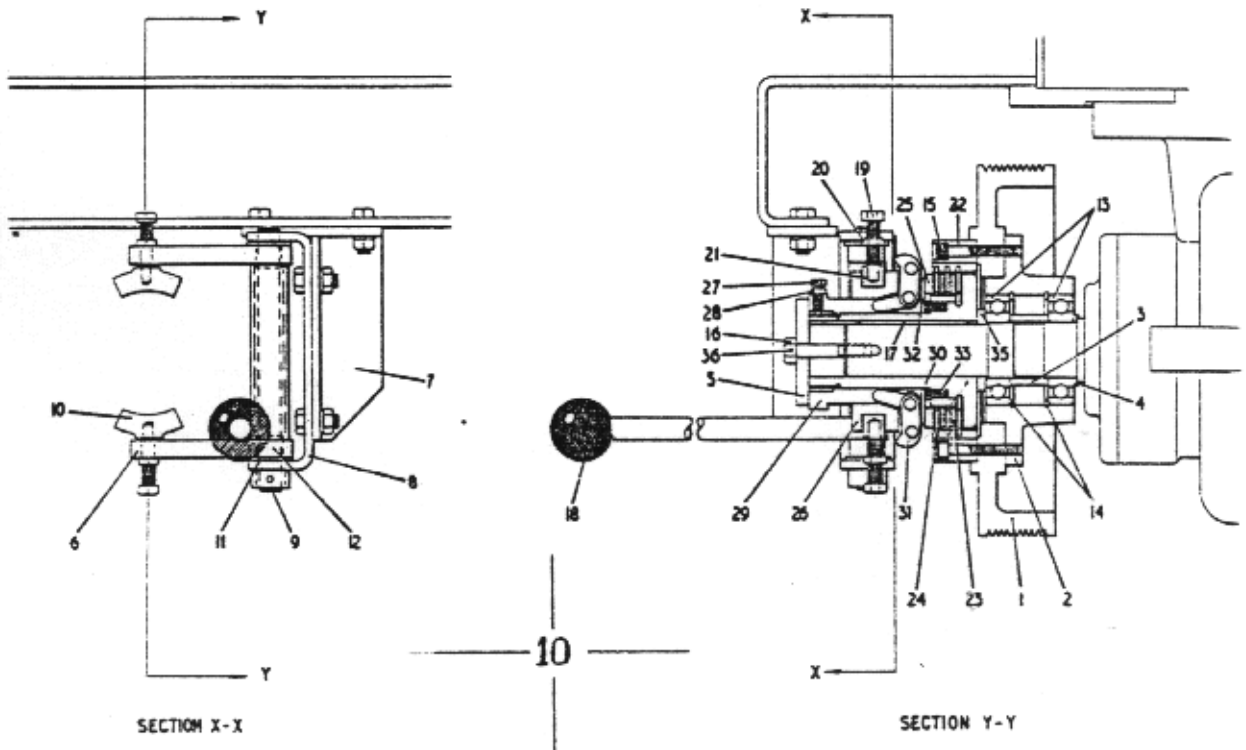

Ref No	Description	Part No	Qty
24	Sintred Discs - 3021	130-93006	3
25	Front Plate - 21645	130-93007	1
26	Sleeve - 22569	130-93008	1
27	Locking Screws - 3261	130-93009	2
28	Locking Nuts - 3507	130-93010	2
29	Adjusting Bush - 20033	130-93011	1
30	Centre - 21641	130-93012	1
31	Lip Link Toggle Assembly - 5312	130-93013	2
32	Pressure Plate - 3177	130-93014	1
33	Springs - 4045	130-93015	3
34	Pins - 3239 (Not Illustrated)	130-93016	2
35	Washer for Clutch Bearing	512-1119	1
36	Locking Wire	477-353	5" Length

CLUTCH

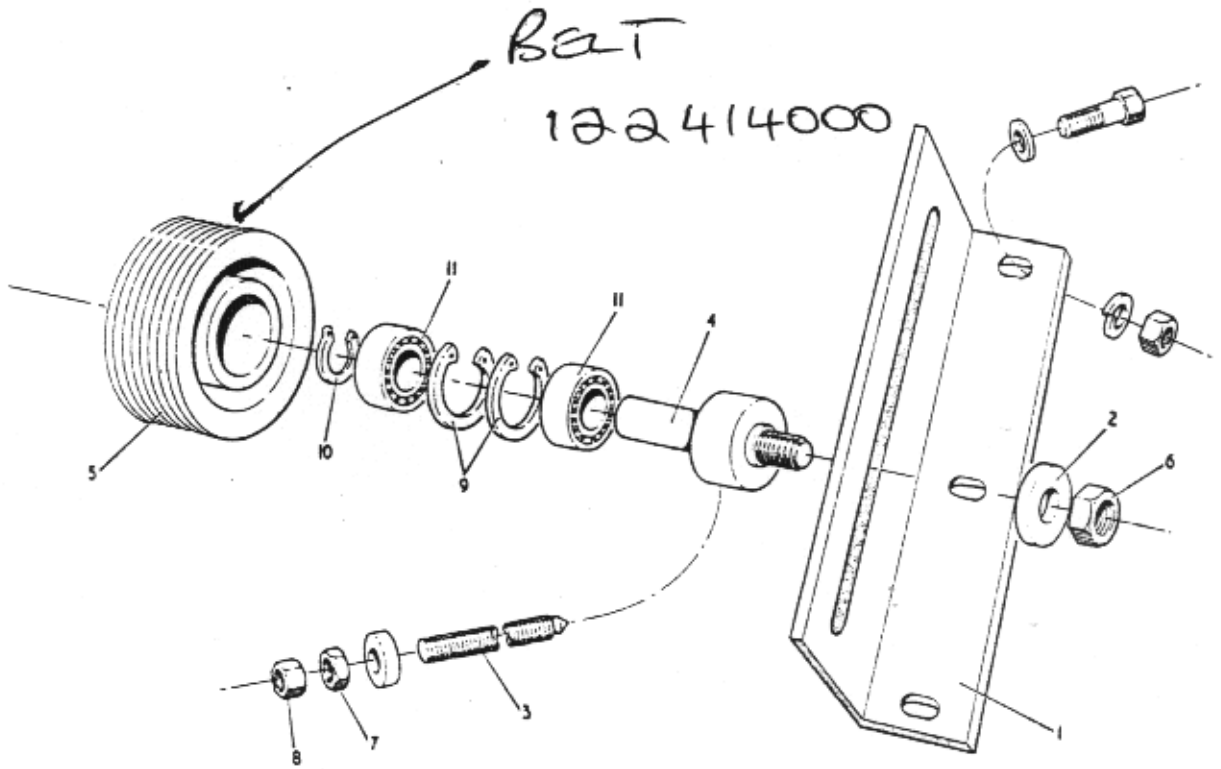

Ref N ^o	Description	Part N ^o	Qty
1	Pivot Shaft Bracket complete with	555-1611	1
	Hex Hd Bolt	460-350812	3
	Hex Nut	330-3508	3
	Spring Washer	464-308	3
	Plain Washer	463-308	3
2	Washer for Jockey Pulley Bracket	555-1615	1
3	Adjusting Screw	555-1620	1
4	Pivot Shaft for Jockey Pulley	555-1614	1
5	Jockey Pulley	555-1609	1
6	Binx Nut	330-3612	1
7	Hex Locknut	330-258	1
8	Hex Nut	331-8508	1
9	Internal Circlip	142-322	2
10	External Circlip	142-320	1
11	Ball Bearing	109-625	2

JOCKEY PULLEY

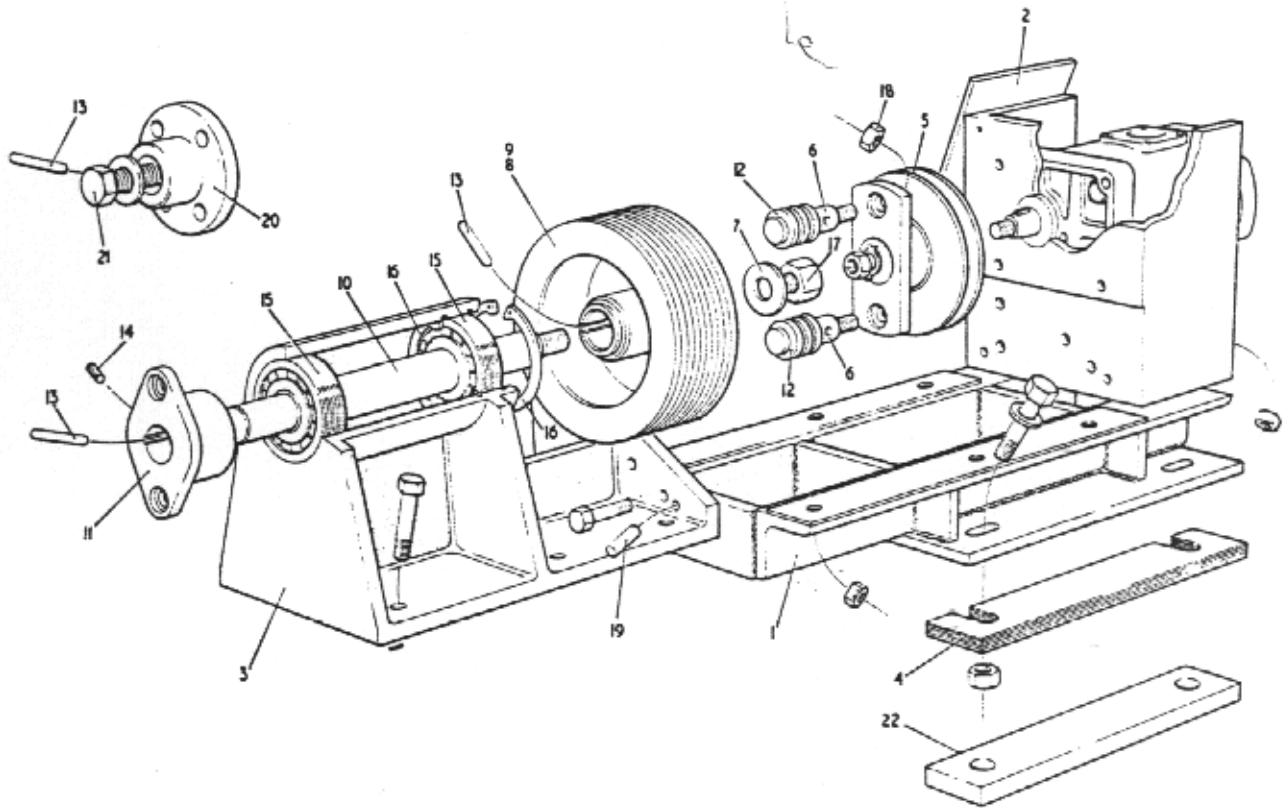

Ref No	Description	Part No	Qty
1	Drive Bearing Support complete with Hex Hd Bolts (Lister & Petter Drive only) Hex Hd Bolts (Electric Drive only) Binx Nuts Plain Washers	555-1685 460-350811 460-350814 330-3608 463-308	1 4 4 4 4
2	Pump Mounting Bracket complete with Hex Hd Bolts Binx Nuts	555-1686 460-350711 330-3607	1 4 4
3	Drive Bearing Bracket complete with Hex Hd Bolt Binx Nut	555-1684 460-350713 330-3607	1 6 6
4	Drive Bearing Support Packers (Electric Drive only)	555-1687	1 Set
5	Pump Pulley	555-1416	1
6	Coupling Pin	555-1616	2
7	Washer for Drive Shaft	555-1617	1
8	Drive Pulley (Diesel)	555-1622	1
9	Drive Pulley (Electric)	555-1625	1
10	Drive Shaft	555-1612	1
11	Drive Shaft Flange (Electric Drive only)	555-1613	1
12	Coupling Rings	137-355	6
13	Parallel Key (Rd Ends)	304-10512	2
14	Cone Pt Setscrew (Electric Drive only)	404-910510	1
15	Ball Bearing	102-93001	2
16	Circlip	142-310	2
17	Binx Nut	330-3610	1
18	Binx Nut	330-3607	2
19	Parallel Dowel Pin	352-1628	2
20	Drive Shaft Flange (Lister & Petter Drives only)	555-1813	1
21	Hex. Hd Setbolt complete with (Lister & Petter Drives only) Plain Washers	418-251008 463-310	1 1
22	Drive Bearing Support Bar	555-1916	2

DRIVE BEARING BRACKET & PUMP MOUNTING

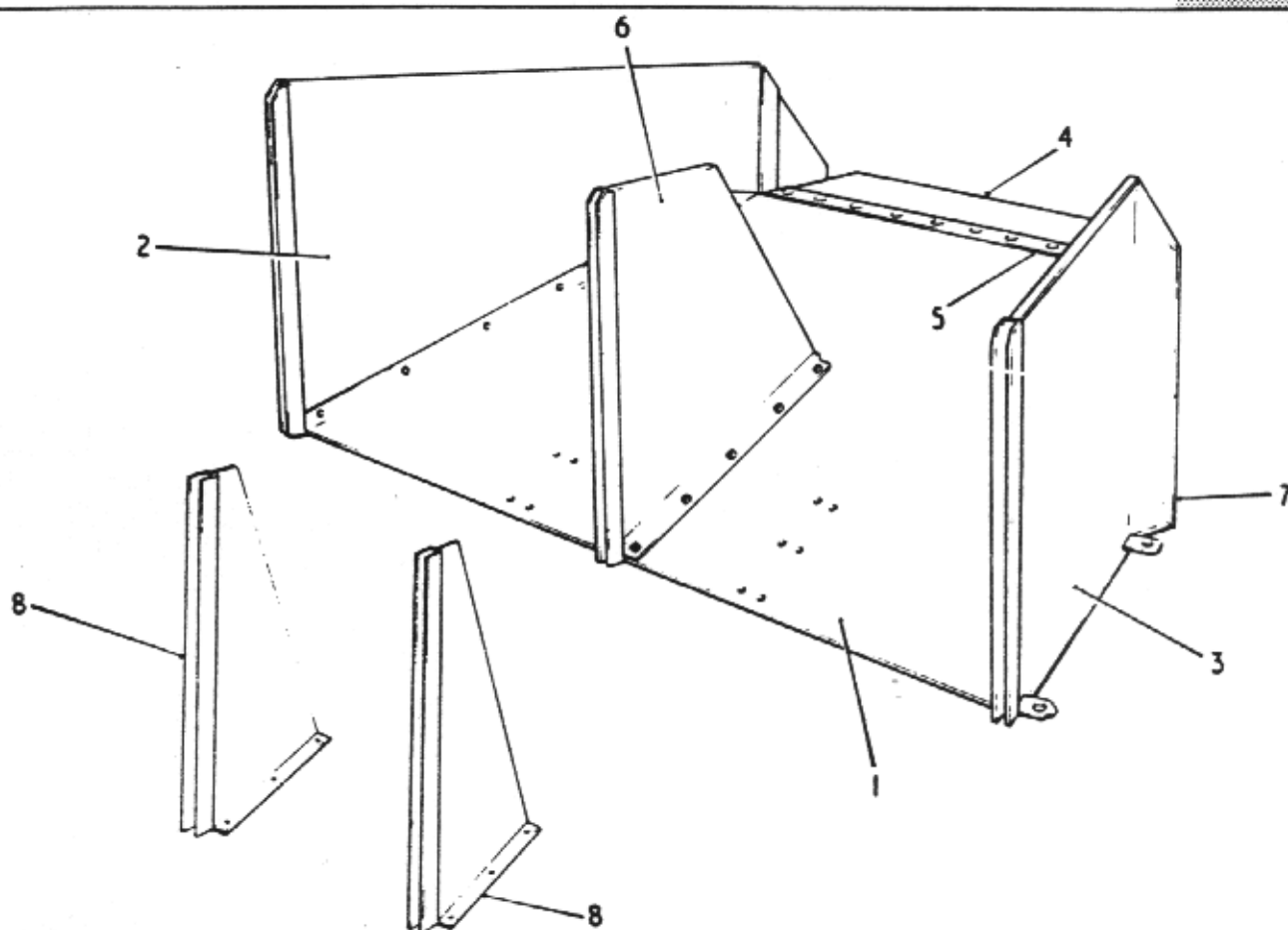

Ref N ^o	Description	Part N ^o	Qty
1	Bottom Ramp Plate	555-1963-1	1
2	R.H. Side Plate complete with Hex Hd Bolts Hex Nuts Spring Washers	555-1963-2-4-10 460-350808 330-350800 464-308000	1 6 6 6
3	L.H. Side Plate complete with Hex Hd Bolts Hex Nuts Spring Washers	555-1963-3-4-10 460-350808 330-350800 464-308000	1 6 6 6
4	Rubber Flap complete with Csk Hd Bolts Nuts Spring Washers	555-1963-12 400-250612 331-8506 464-306	1 10 10 10
5	Rubber Retaining Strap	555-1963-15	1
6	Centre Partition Two Compartments complete with Hex Hd Bolts Hex Nuts Spring Washers	555-1963-4-6-7-11 460-350808 330-350800 464-308000	1 10 10 10
7	Centre Support Angle complete with Hex Hd Bolts Hex Nuts Spring Washers	555-1963-8-9 460-350808 330-350800 464-308000	1 8 8 8
8	Dividers for Three Compartments complete with Hex Hd Bolts Hex Nuts Spring Washers	555-1048 460-350808 330-350800 464-308000	1 LH. 1 RH 12 12 12

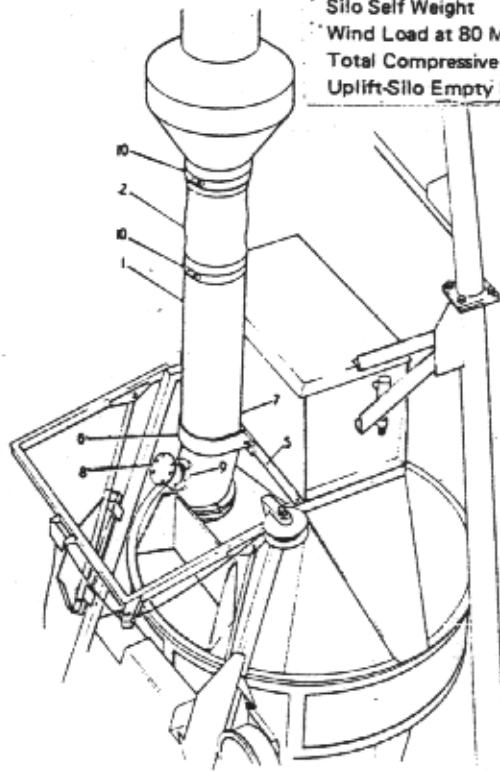
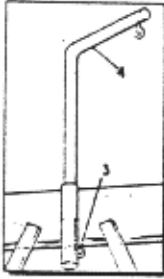

BASE LOAD TABLE

	TONS PER BASE PLAGE	
	P20	P30
Silo Contents	5.0	7.5
Silo Self Weight	0.75	0.75
Wind Load at 80 M.P.H.	1.6	2.35
Total Compressive Load	7.35	10.6
Uplift-Silo Empty 80 M.P.H. Wind	0.35	1.6

Ref N ^o	Description	Part N ^o	Qty
1	Cement Chute complete with	555-1748	1
	Hex Hd Bolts	460-50610	6
	Hex Nuts	331-850600	6
	Spring Washers	464-306000	6
2	Silo Batcher Sock	555-2049	1
3	Support Bracket to Pedestal	555-1741	1
4	Cable Support	50-44259	1
5	Support Angle for Cement Chute complete with	555-1749	1
	Hex Hd Bolts	460-50812	2
	Hex Nuts	331-850800	2
	Spring Washers	464-308000	2
6	Strap For Cement Chute complete with	555-1750	1
	Hex Hd Bolts	460-50810	2
	Hex Nuts	331-850800	2
	Spring Washers	464-308000	2
7	Rubber Pad for Cement	555-1751	1
	CSK Hd Setscrews	400-554080	2
	Binx Nuts	335-760400	2
	Plain Washers	464-304000	2
8	Cover for Cement Chute complete with	555-1752	1
	Hex Hd Setscrews	418-350606	6
	Spring Washer	464-306000	6
9	Cement Chute Flange Gasket	555-1545	1
10	Clip	132-130000	2
11	Foundation Bolts (not illustrated)	555-1746	16

CALIFORNIA

Proposition 65 Warning

Diesel engine exhaust and some of its constituents are known to the State of California to cause cancer, birth defects, and other reproductive harm