

WINGET

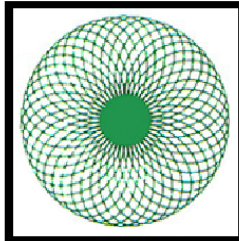

Croker

CUMFLOW RP550XD/RP850XD WEIGHER, LOADER FRAME & HOPPER PARTS MANUAL

**WINGET LIMITED
PO BOX 41
EDGEFOLD INDUSTRIAL ESTATE
PLODDER LANE
BOLTON
LANCS
BL4 OLS
Tel: ++ 44 (0)1204 854650
Fax:++ 44 (0)1204 854663
crokersales@winget.co.uk
parts@winget.co.uk
www.winget.co.uk**

CROKER CUMFLOW RP550XD/RP850XD WEIGHER, LOADER FRAME AND HOPPER

This manual must be read in conjunction with the Parts and Operators Manual issued with the original equipment. The Parts & Operators Manual contains additional important detailed advice regarding the correct procedures to be followed during Pre-Installation, Installation, Operation and ongoing Care and Maintenance of the equipment

The contents of this handbook although correct at the time of publication, may be subject to alteration by the manufacturers without notice and Winget Limited can accept no responsibility for any errors or omissions contained within the following pages. Nor can we accept any liability whatsoever arising from the use of this manual howsoever caused.

Winget Limited operate a policy of continuous product development, therefore, some illustrations or text within this publication may differ from your machine

Winget Limited can accept no responsibility for incorrectly supplied spare parts unless the part number and a full description of the items required is given when the order is placed.

NOTE

Imperial fixings (bolts, setscrews, nuts, washers etc) have been progressively changed to Metric. If in doubt as to whether you have a Metric or Imperial fixing please order the metric items listed, i.e. bolt or setscrew and associated or flat and spring washers to replace the existing items.

COMPANY DETAILS AND GENERAL INFORMATION

For any spares or service work, please contact:-

Winget Limited
P.O. Box 41
Edgefold Industrial Estate
Plodder Lane
Bolton
Lancs U.K.
BL4 OLS

Telephone No: ++ 44 (0)1204 854650
Facsimile No: ++ 44 (0)1204 854663
'E Mail' crokersales@winget.co.uk
 parts@winget.co.uk

ORDERING SPARES

To help us to complete your order promptly and correctly we need:-

- Machine type and serial number
- Description and quantity of parts required
- The full address to which the parts are to be sent

Winget Limited can accept no responsibility for incorrectly supplied spare parts unless the part number and a full description of the items required is given when the order is placed.

WARNING

THE MANUFACTURER ACCEPTS NO RESPONSIBILITY FOR ANY DAMAGE OR FAILURE RESULTING FROM OPERATIONAL MISUSE OR MALPRACTICE. ANY MODIFICATIONS TO THE MACHINE WILL AFFECT ITS WORKING PARAMETERS AND SAFETY FACTORS. REFER TO THE MANUFACTURERS BEFORE FITTING ANY NON STANDARD EQUIPMENT OR PARTS.

THE MANUFACTURERS ACCEPT NO RESPONSIBILITY FOR ANY MODIFICATIONS MADE AFTER THE MACHINE HAS LEFT THE FACTORY, UNLESS PREVIOUSLY AGREED IN WRITING. THE MANUFACTURERS WILL ACCEPT NO LIABILITY FOR DAMAGE TO PROPERTY, PERSONNEL OR THE MACHINE IF FAILURE IS BROUGHT ABOUT DUE TO SUCH MODIFICATIONS, OR THE FITMENT OF SPURIOUS PARTS.

OPERATING THE MIXER/LOADER/WEIGHER

SAFETY NOTES

Never operate the mixer unless you have read and fully understand the contents of the Operators Manual

Never operate the mixer whilst wearing loose fitting clothing

Never reach inside the Pan whilst it is rotating

Never operate any equipment unless you have received adequate training

Cement, certain other minerals and organic compounds can cause skin irritation leading to Dermatitis. Always use Personal Protective Equipment i.e. gloves etc to protect the skin from direct contact. If in any doubt about the materials being used consult your employers COSHH manual

Wear Eye protection to protect your eyes from dust and liquid splashes

Do not attempt to remove the pan single handedly, obtain assistance, use the Pan Trolley (if provided) or use suitable lifting equipment

Do not operate the mixer with any of the guards removed, safety devices or interlocks disconnected. They are there to offer you some protection, ensure they are correctly maintained

Carry out the daily maintenance before operating the mixer and report defects to your supervisors

Oils, Greases and Lubricants are skin irritants and prolonged direct skin contact can cause skin cancer. PPE or barrier creams should be used when carrying out maintenance work, wash your hands on completion

Always dispose of waste oils and lubricants in a proper manner, it is illegal to pour it down drains or bury it. Contact your local authority for a list of authorised disposal sites

Always disconnect the power supply at the mains before carrying out any maintenance work or cleaning the equipment down. Do not turn on the power until everything has dried out

Do not allow waste from the wash down process to enter the public drainage system unless it has been properly filtered.

Decals and Instruction Plates are attached to the equipment to warn against hazards and assist in the safe operation of the equipment, if damaged or defaced they should always be replaced.

It is likely that clutch and/or brake linings may contain asbestos and suitable precautions should be taken to avoid breathing in the dust, protective clothing should be worn. Hands should be washed immediately after handling components and old discarded parts or linings should be disposed of in a responsible manner in line with local or national regulations covering the disposal of asbestos waste.

OPERATING INSTRUCTIONS FOR WEIGHGEAR MECHANISM

HYDROSTATIC LOADCELL & GAUGE

The Hydrostatic Load Cell is connected by a flexible capillary tube (approx 9.7 metres long) to a 300mm (12”) diameter weigh gauge.

The whole system is assembled and filled with fluid under vacuum and under no circumstances should any of the components be disconnected, in the event of component damage the complete assembly should be returned to Winget Limited for repair.

The system is factory calibrated and any variation between the calculated tare and the actual tare recorded can be corrected by means of the tare adjustment knob on the side of the gauge.

With no load acting on the Loadcell the pointer will be below zero, this is to accommodate the weight of the hopper. When the hopper is placed on to the Loadcell the pointer will register zero. Final zero adjustment can be made via the zero adjustment knob on the side of the gauge housing.

ELECTRONIC LOADCELL & GAUGE

The electronic Loadcell & Gauge consists of an electrically operated loadcell mounted on the weigher frame and connected to a remote mounted digital readout control box. The connecting lead should be protected from damage and the readout box mounted such that it is not affected by vibrations etc. The mounting instructions detailed within both Section 9 of the Operators Manual and the Operators manual for the Electronic Loadcell and Readout/Indicator Box should be followed to avoid excess vibrations damaging the control box. Both manuals also contain detailed advice on setting up, obtaining zero and operation of the Loadcell and Readout Box and should be referred to before the equipment is operated.

NOTE THE FOLLOWING WIRING CONNECTIONS

- + Excite RED
- Excite BLUE

- + Signal GREEN
- Signal YELLOW

RP550XD/850XD ARRANGEMENT OF WEIGHER & LOADING HOPPER

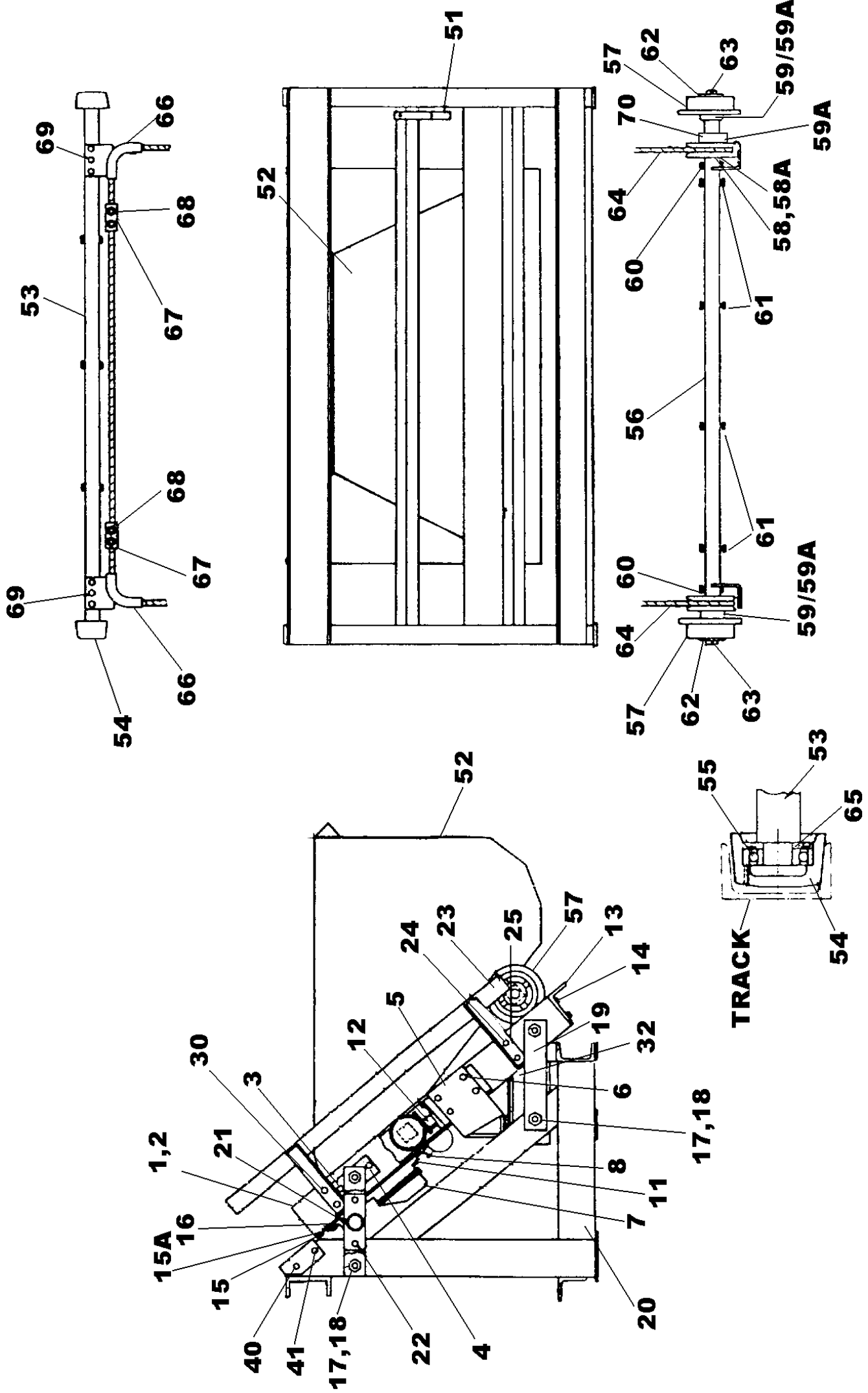

RP550XD/850XD ARRANGEMENT OF WEIGHER & LOADING HOPPER

1	CR260338	Runway Opp. Limit Switch Side	1
2	CR260338	Runway Limit Switch Side	1
3	CR260062	Runway Hinge Pin	2
4	52S06G	Runway Hinge Pin C/Sunk Bolts M16 x35	4
4A	267S09	Washer Flat M16	4
4B	17S08	Washer Spring M16	4
4C	7S06	Nut M16	4
5	CR260334	Bridge	1
6	11S06G	Bridge Screw Sets M16 x 45	8
6A	267S09	Washer Flat M16	8
6B	17S08	Washer Spring M16	8
6C	7S06	Nut M16	8
7	CR220005	Limit Switch, NLA use CR229083	1
8	CR220100	Limit Switch Arm, NLA use CR229083	1
9	CR530450	Limit Switch Plate	1
10	52S05H	Limit Switch Plate C/Sunk Screws M12 x 40	4
10A	17S06	Washer Spring	4
10B	7S05	Nut	4
11	8S03D	Limit Switch Securing bolts (for CR220100) M8x40	4
11A	267S05	Washer Flat M8	8
11B	17S04	Washer Spring M8	4
11C	7S03	Nut M8	4
11D	8S01D	Limit Switch Securing bolts (for CR229083) M5x40	4
11E	17S02	Washer Spring M5	4
11F	7S01	Nut M5	4
12	CR260065	Hopper stop	1PR
13	CR260335	Runway Tie	1
14	8S06D	Runway Tie Bolts M16 X 40	4
14A	267S09	Washer Flat M16	4
14B	17S08	Washer Spring M16	4
14C	7S06	Nut M16	4
15	CR260337	Runway Brace	2
15A	8S06D	Runway Brace Bolts M16 X 40	4
15B	267S09	Washer Flat M16	4
15C	17S08	Washer Spring M16	4
15D	7S06	Nut M16	4
16	52S06J	Runway Brace C/Sunk Screws M16 x 45	4
16A	267S09	Washer Flat M16	4
16B	17S08	Washer Spring M16	4
16C	7S06	Nut M16	4
17	8S08T	Link Bolts M24 x 140	6
17A	267S12	Washer Flat M24	14
17B	17S11	Washer Spring M24	8
17C	7S08	Nut M24	6
18	CR180014	Rubber Bearing Silentbloc	8
19	CR260063	Link	4
20	CR260154	Weigher Frame	1
21	CR260064	Torque Tube (state machine number)	1
22	8S06G	Torque Tube Bolts M16 x 55	4

RP550XD/850XD ARRANGEMENT OF WEIGHER & LOADING HOPPER

22A	267S09	Washer Flat M16	4
22B	17S08	Washer Spring M16	4
22C	7S06	Nut M16	4
23	CR260336L	Guide Rail Left Hand	1
23A	CR260336R	Guide Rail Right Hand	1
24	11S05F	Guide Rails Screw Set M12 X 40 (Lower)	4
24A	267S07	Washer Flat M12	4
24B	17S06	Washer Spring M12	4
24C	7S05	Nut M12	4
25	CR530600	Guide Rail Packings	4
30	52S05J	Guide Rails C/Screw M12 X 45 (Upper)	4
30A	267S07	Washer Flat M12	4
30B	17S06	Washer Spring M12	4
30C	7S05	Nut M12	4
40	8S06D	Runway Bolts M16 X 40	4
40A	267S09	Washer Flat M16	4
40B	17S08	Washer Spring M16	4
40C	7S06	Nut M16	4
41	52S06G	Runway C/Sunk Bolts M16 x35	4
41A	267S09	Washer Flat M16	4
41B	17S08	Washer Spring M16	4
41C	7S06	Nut M16	4
51	CR540344	Limit Swtich Striker	1
52	CR541293	Loading Hopper (550/850)	1
53	CR520131	Loading Hopper Front Axle	1
54	CR21100097	Loading Hopper Front Axle Roller	2
55	CR150844	Loading Hopper Front Axle Roller Bearing	2
56	CR520132	Rear Axle	1
57	CR210157	Rear Axle Roller	2
58	CR210160	Rear Axle Rope Pulley	2
58A	267S13	Waher Flat, M48 Rope Pulley	2
59	CR630209	Rear Axle Collar	2
59A	57S05D2	Screw Grub Rear Axle Collar M8 x 10	3
60	8S05L	Rear Axle Bolts Short M12 x 75	2
60A	17S06	Washer Spring M12	2
60B	7S05	Nut M12	2
61	8S05N	Rear Axle Bolts Long M12 X 90	4
61A	17S06	Washer Spring M12	4
61B	7S05	Nut M12	4
62	10S43	Rear Axle Flat Washer 1.5"	2
63	44S06L	Rear Axle Split Pin	2
64	CR350008	Hopper Rope (when ordering quote machine no:)	1
65	CR530602	Front Axle Washer	2
66	CR260436	Front Axle Rope Guide	2
67	CR530603	Front Axle Rope Retainer Block	2
68	CR530587	Front Axle Rope Anchor Bolts (Special)	4
69	8S05L	Front Axle Rope Anc. Guide Bolts M12 x 75	6
69A	17S06	Washer Spring M12	6
69B	7S05	Nut M12	6
70	CR639010	Collar, Rope Pulley Retaining	1

RP550XD/850XD ARRANGEMENT OF WEIGHER & LOADING HOPPER

FIXINGS FOR ELECTRONIC LOADCELL (NOT ILLUSTRATED)

71	8S06D	Bolts M16 X 40	4
71A	267S09	Washer Flat M16	4
71B	17S08	Washer Spring M16	4
71C	7S06	Nut M16	4

ELECTRONIC LOADCELL & DIGITAL READOUT BOX (NOT ILLUSTRATED)

72	CR179022	Loadcell	1
73	CR179028	Indicator, Digital Readout Box	1

CROKER LOADER

WARNING:

BEFORE WORKING UNDER LOADING HOPPER, REST THE HOPPER ON SAFETY BOLTS. DO NOT FORGET TO REMOVE THESE BOLTS BEFORE RE-STARTING THE MACHINE

WIRE ROPE RENEWAL PROCEDURE

Place Loader Hopper on hopper stops. Loosen nut from rope anchor bolt, item 1, on one rope drum only, item 2.

Remove end of old wire rope from anchor bolt.

Fit end of new wire rope to anchor bolt and tighten nut.

Lay other end of new wire rope end to end with old wire rope removed in part 2. Bind both ends together with sticky tape (electrical or masking tape).

Carefully pull on the old wire rope to pull the new wire down to the bottom of the loader bin and around the rear axle rope pulley, item 3, and up through the front axle rope guide, item 4.

Remove front axle rope retainer blocks, items 5 and 6, and slide onto the new rope.

Continue to pull the wire and thread through the second rope guide, item 7, and down around the second rope pulley, item 8, and up to the second rope drum, item 9.

Remove old wire from second anchor bolt, item 10, on second rope drum, item 9, and remove tape from ends of old and new wire.

Fit second end of new wire to second anchor bolt, item 10, on second rope drum, item 9.

Tighten anchor bolt nuts on both rope drums.

The new wire should now run over the front edges of both rope drums and down to front edges of both the lower axle rope pulleys, items 3 and 8, and up the back of the rope pulleys to the rope guides, items 4 and 7, with both

WIRE ROPE RENEWAL PROCEDURE

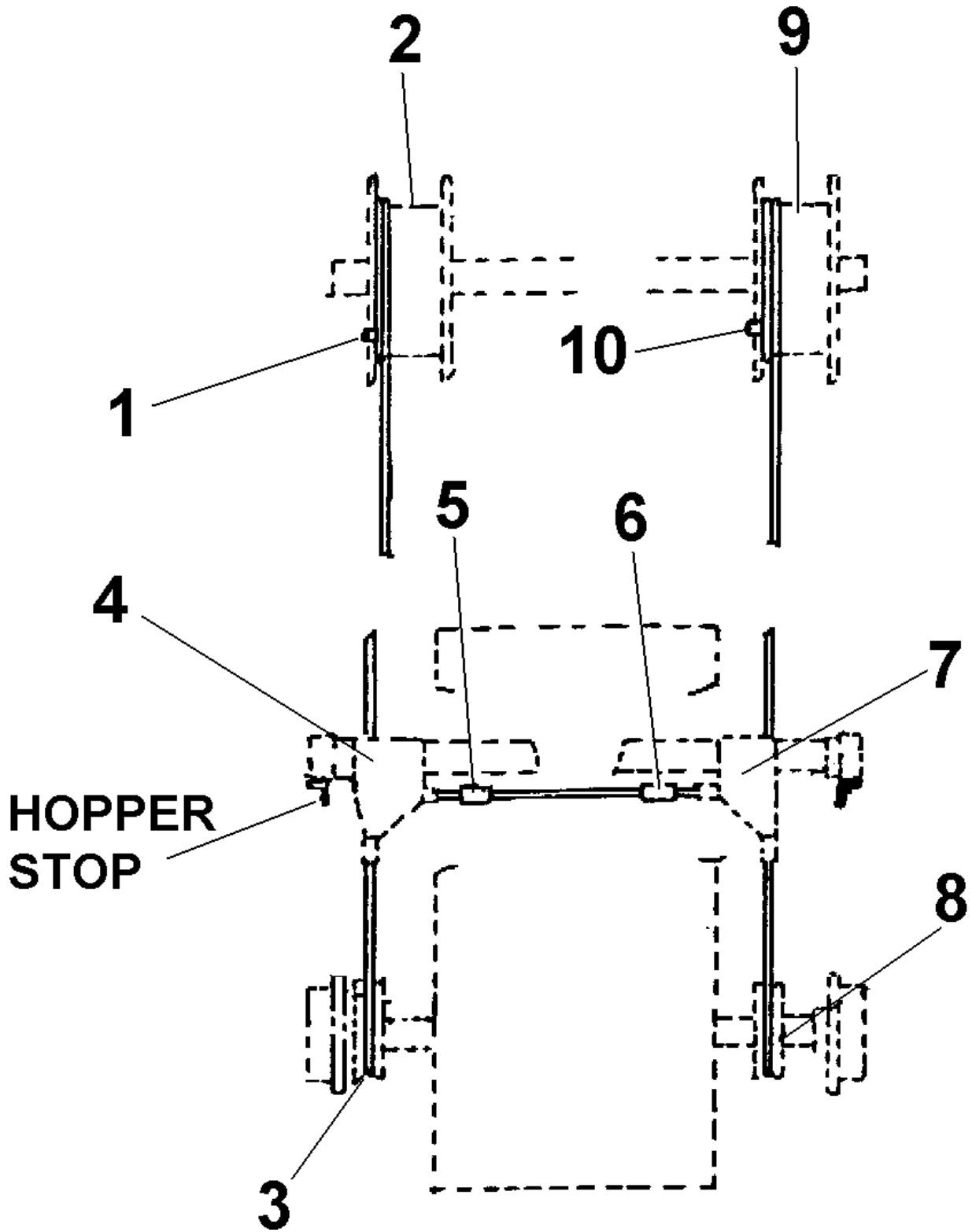

rope retainer blocks, items 5 and 6, located on the section of wire rope between the two rope guides at the back of the bin.

Start and stop the loader by hand, using the start and stop buttons, and take out all the slack of the wire rope in the raise direction (see important note on page 30), ensuring that the wire slots into both axle rope pulleys, item 2 and 9, and that the wire has wound evenly onto both rope drums.

Make sure the loader hopper is level and sitting on weigher track stops before positioning rope retainer blocks, items 5 and 6, approximately 2 inches (50 mm) in board of rope guides, item 4 and 7, each side and make fast retainer blocks onto wire.

Check that both limit switches are working correctly.

Make sure Loader Hopper clears both sides of rope drums at the top of its operation.

NOTE: Hopper stops between rope drums.

IMPORTANT NOTE

Ensure that the slack wire is taken up in the raise direction and not the lowering direction. If the rope is wound incorrectly in the reverse direction on to the rope drums the hopper will not stop at the upper limit switch. It will continue until it makes contact with the top of the structure and will continue to heave until the wire rope breaks, with the result, if both sides of the wire fail at the same time, that the hopper will drop to the bottom end of the skip track.

SERVICING

FIRST 500 HOURS AND ANUALLY THEREAFTER:

CHANGE THE OIL IN THE WINCH REDUCTION GEARBOX

Drain and clean out the gear case and refill with Total Cortis 220 or Total Carter EP220 or Shell Vitrea Oil 55 or Macoma 75 or equivalent. When running conditions are severe this procedure should be adopted more frequently. (Capacities, dependant on make and model of reduction gearbox 10 Imperial Pints: 5.7 Litres: 1.6 American Gallons).

Keep the winch unit wire rope clean and regularly apply a suitable wire rope dressing

RP550XD/RP850XD LOADER RUNWAY ASSEMBLY

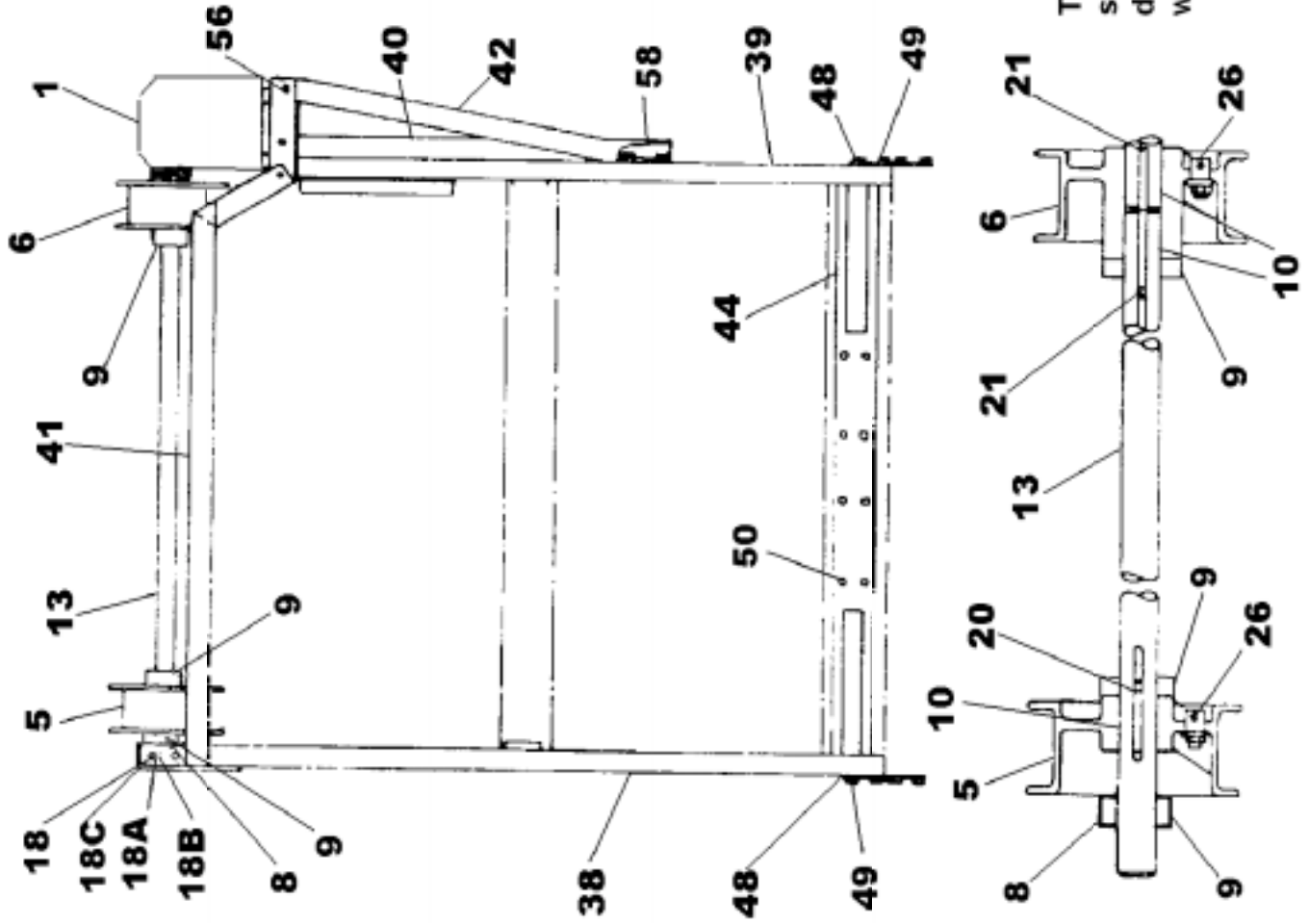
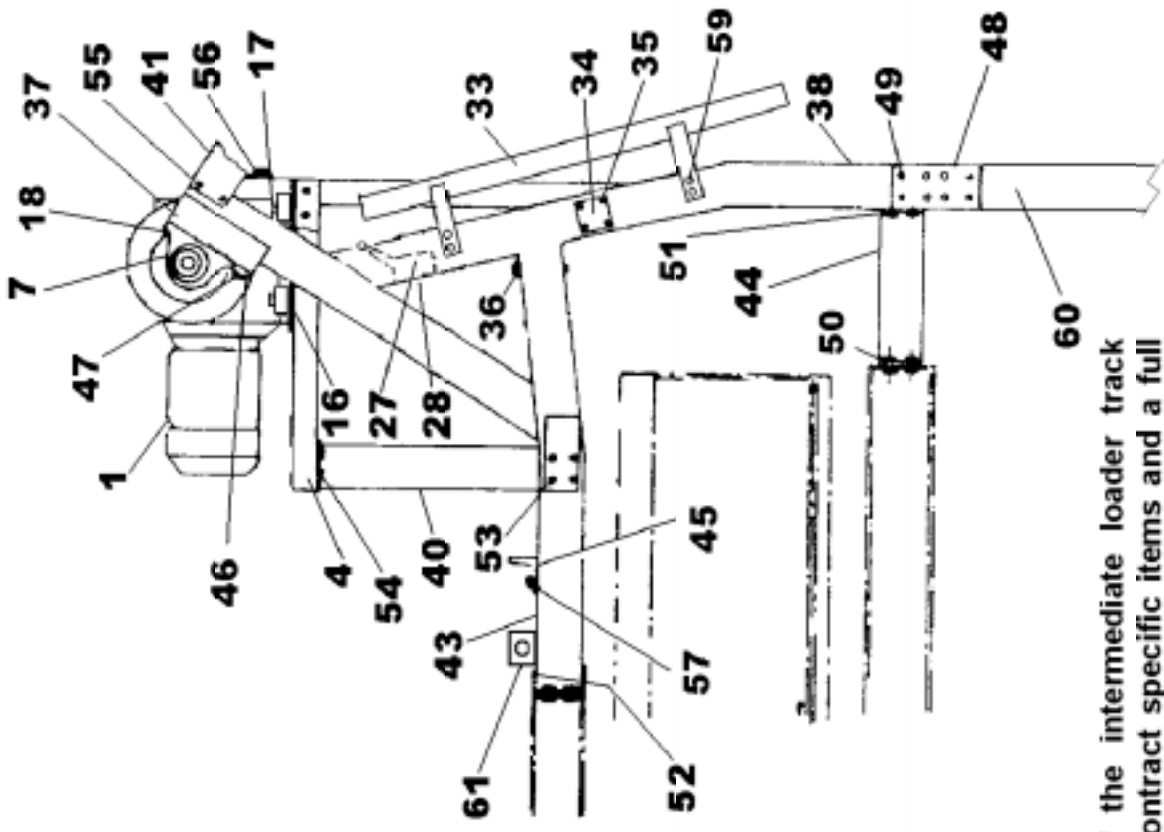

The length of the intermediate loader track sections are contract specific items and a full description including the length must be given when ordering replacements

RP550XD/RP850XD LOADER RUNWAY

1	CR299114	Combined Motor Brake & Gear Unit	1
4	CR269161	Motor Bedplate	1
5	CR21100101	Rope Drum	1
6	CR21100102	Rope Drum Motor Side	1
7	CR151096	Rope Drum Shaft Support Bearing	1
8	CR630244	Shaft Locking Collar	1
9	57S07F1	Screw Grub M12 x 16	3
10	CR569028	Loctite Fluid	1
13	CR52100119	Rope Drum Shaft	1
16	61S07	Nut Binx M20	4
17	8S07N	Bolt M20 x 90	4
17A	267S10	Washer Flat M20	4
18	8S06H	Bolt M16 x 60	2
18A	267S09	Washer Flat M16	2
18B	17S08	Washer Spring M16	2
18C	7S06	Nut M16	2
20	CR329072	Key Parallel 18 X 11 X 40	1
21	CR329092	Key Parallel 18 X 11 X 100	2
26	CR530587	Rope Anchor Bolts (Special)	2
27	CR229083	Limit Switch	1
27A	8S01C	Limit Switch Retaining Bolts M5	4
27B	17S02	Washer Spring M5	4
27C	267S03	Washer Spring M5	4
27D	7S01	Nut M5	4
28	CR54100788	Bracket Limit Switch	1
28A	11S03C	Screw Set M8 x 25	2
28B	105S02	Washer Tapered M8	2
28C	267S05	Washer Flat M8	2
28D	59S12	Nut Nyloc M8	2
29	CR229178	End Stop Limit Switch (Not Illustrated)	2
33	CR260336L	Guide Rail LeftHand	1
33A	CR260336R	Guide Rail Right Hand	1
34	CR620006	Caution Plate	2
35	11S02B	Screw Set M6 X 20	8
35A	267S04	Washer Flat M6	16
35B	17S03	Washer Spring M6	8
35C	7S02	Nut M6	8
36	CR530599	Hopper Safety Bolt & Chain	2
37	CR26100115	Bearing Support Angle	1
38	CR53100125	Runway, Opposite Winch Unit Side	1
39	CR53100124	Runway, Winch Unit Side	1
40	CR530592	Winch Unit Support Channel	1
41	CR261099	Runway Cross Tie	1
42	CR260358	Winch Unit Support Angle	1
43	CR530594	LH & RH Runway Tie Channels	2
44	CR53100128	Runway, Bottom Support Assembly	1
45	CR53100127	Loader Tie	1
46	CR530039	Bearing Stop	1
47	11S06H	Screw Set M16 x 50 Bearing Stop	1

RP550XD/RP850XD LOADER RUNWAY

47A	267S09	Washer Flat M16	1
47B	17S08	Washer Spring M16	1
47C	7S06	Nut M16	1
48	CR530597	Runway GussetPlate	2
49	52S05G	Gusset Plate C/Sunk Screw Set M12 x 35	16
49A	267S07	Washer Flat M12	16
49B	17S06	Washer Spring M12	16
49C	7S05	Nut M12	16
50	11S06T	Bottom Support-Mixer Screw Set M16 x	8
50A	267S09	Washer Flat M16	16
50B	17S08	Washer Spring M16	8
50C	7S06	Nut M16	8
51	52S05G	Bottom Support-Runway C/Sunk Sets M12 x 35	4
51A	267S07	Washer Flat M12	4
51B	17S06	Washer Spring M12	4
51C	7S05	Nut M12	4
52	11S06H	Runway Tie Channel Screw Set M16 x 50	8
52A	267S09	Washer Flat M16	8
52B	17S08	Washer Spring M16	8
52C	7S06	Nut M16	8
53	11S06F	Runway Tie Screw Set M16 x 40	8
53A	267S09	Washer Flat M16	8
53B	17S08	Washer Spring M16	8
53C	7S06	Nut M16	8
54	11S06G	Winch Support Channel Screw Set M16 x 45	4
54A	267S09	Washer Flat M16	4
54B	17S08	Washer Spring M16	4
54C	7S06	Nut M16	4
55	11S06F	Runway Cross Tie Screw Set M16 x 40	4
55A	267S09	Washer Flat M16	4
55B	17S08	Washer Spring M16	4
55C	7S06	Nut M16	4
56	11S06H	Winch Support Angle Screw Set M16 x 50	4
56A	267S09	Washer Flat M16	4
56B	17S08	Washer Spring M16	4
56C	7S06	Nut M16	4
57	11S06H	Loader Tie Angle Screw Set M16 x 50	2
57A	267S09	Washer Flat M16	2
57B	17S08	Washer Spring M16	2
57C	7S06	Nut M16	2
58	52S05J	Winch Support Angle C/Sunk Set M12 x 45	2
58A	267S07	Washer Flat M12	2
58B	17S06	Washer Spring M12	2
58C	7S05	Nut M12	2
59	52S05G	Guide Rail C/Sunk Screw Sets M12 x 35	8
59A	267S07	Washer Flat M12	8
59B	17S06	Washer Spring M12	8
59C	7S05	Nut M12	8

RP550XD/RP850XD LOADER RUNWAY

60	N.P.N	LH & RH Intermediate Runway Sections Quote length and section dimensions	2
61	CR530630	Lifting Eyes (Weldable)	2