

# WINGET

## PARTS & OPERATORS HANDBOOK PRESSURE WASHERS



WINGET LIMITED  
PO BOX 41  
EDGEFOLD INDUSTRIAL ESTATE  
PLODDER LANE  
BOLTON  
GT MANCHESTER  
U.K.  
BL4 0LR  
Tel: ++ 44 (0) 1204 854650  
Fax: ++ 44 (0) 1204 854663  
[www.winget.co.uk](http://www.winget.co.uk)  
Issue 4 2011

# CONTENTS

- 1 Introduction**
- 2 Declaration of Conformity**
- 4 Identification**
- 5 Warranty Terms & Conditions**
- 7 Safe Working**
- 12 Operation**
- 18 Maintenance and Service**
- 22 Technical Information**
- 25 Parts Listings**

The contents of this Handbook although correct at the time of publication, may be subject to alteration by the manufacturers without notice.

Winget Limited operate a policy of continuous product development. Therefore, some illustrations or text within this publication may differ from your machine.

**WARNING:** The operator must read both this handbook and the Engine Operators Handbook and be familiar with all the controls before attempting to operate this machine.

The contents of this handbook are designed as a guide to the machines controls, operation, working capacities and maintenance. It is not a training manual.

These are the original Instructions in the English Language issued by Winget Limited to comply with the requirements of Directive 2006/42/EC

# WINGET

WINGET LIMITED  
Registered in England No. 1977110

Registered Office:  
P.O. Box 41  
Edgefold Industrial Estate  
Plodder Lane  
Bolton Lancs. BL4 0LS

Tel: (01204) 854650  
Fax: (01204) 854663 Parts/Purchasing  
Fax: (01204) 854664 Winget Sales  
Fax: (01204) 854663 Croker Sales  
Fax: (01204) 854663 Service/Engineering  
Fax: (01204) 854625 Accounts Enquiries  
E mail: [service@winget.co.uk](mailto:service@winget.co.uk)  
Web Site: [www.winget.co.uk](http://www.winget.co.uk)

## DECLARATION OF CONFORMITY

We: Winget Limited,

Of P.O. Box 41, Plodder Lane, Bolton, Lancs, England BL4 0LR declare that the following TASKMAN Pressure Washers:-

Models:- PW100PH10/11/12, PW140PH12, PW150PH8/12/14, PW170PH15  
PW170DY15, PW200PH13/15/21, PW200DY15, PW90PH12

Serial Numbers:- 1000-99000

To which this declaration relates, with a maximum net installed power of 6.5Kw. Having been tested in accordance with the Conformity Assessment Procedure detailed in Annexe V of Directive 2000/14/EC is in conformity with the provisions of the "Noise Emission in the Environment by Equipment for use Outdoors Directive 2000/14/EC". Representative samples of this equipment was tested and Sound Power Levels (Lwa) recorded of:-

PW100PH10	102db
PW100PH11	97db
PW100PH12	101db
PW140PH12	105db
PW150PH8	102db
PW150PH12	105db
PW150PH14	103db
PW170PH15	104db
PW170DY15	111db
PW200PH13	107db
PW200PH15	107db
PW200PH21	105db
PW200DY15	110db
PW9012	104db

We guarantee under the provisions of the above Directive (2000/14/EC) that the Sound Power Levels for these equipment models will not exceed:-

PW100PH10	104db
PW100PH11	99db
PW100PH12	104db
PW140PH12	107db
PW150PH8	104db
PW150PH12	107db
PW150PH14	106db
PW170PH15	106db
PW170DY15	114db
PW200PH13	109db
PW200PH15	109db
PW200PH21	108db
PW200DY15	114db
PW9012	106db

We also declare that the above equipment is also in accordance with the following EC Directives:-

**2006/42/EC**

**2004/108/EC**

**Bolton 24.03.10**

Place and date of issue

**S. Hodge**

Name and signature or equivalent marking of authorised person.

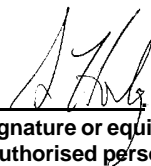

**Joint Managing Director**

Position

The above named person is also responsible for holding the Technical Documentation applicable to the product to which this declaration relates and may be contacted at the address which appears at the head of this declaration

Please take care of this document, as duplicate copies are not available.

This document is in accordance with EN45014:1989



PW90PH12



PW100PH11  
PW100PH12



PW140PH12



PW140PH12T



PW100PH10GC  
PW150PH12GC



PW170PH15  
PW200PH13  
PW150PH14



PW200PH15  
PW200PH21



PW200DY15E



PW200DY15ES

**Winget Limited assures you that if any of the parts identified within the Parts section of this manual become defective due to faulty manufacture or materials within 6 months from the date of purchase when used commercially, or 12 months for domestic customers, the part will be repaired or replaced under warranty free of charge by any authorised Winget Limited Distributor.**

**Warranty repairs *must* be carried out by an authorised distributor, unless prior agreement has been agreed in writing with the Warranty Department at Winget Limited.**

**This warranty is given to the first owner and may be transferred to subsequent owners for the balance of the Warranty period.**

**Winget Limited's liability only extends to the costs of repair or replacement of the faulty parts and necessary labour charges involved in the repairs. The company accepts no liability for any consequential loss, damage or injury, resulting directly or indirectly from any defect in the goods.**

**Items not covered by Warranty and considered to be the customers responsibility include normal maintenance services; replacement of service items and consumables; replacement required due to abuse, accident, misuse or improper operation; replacement of wearable items e.g. hoses, lances, pins bushes etc.**

**All Warranty repairs on the petrol or diesel engine must be carried out by the engine manufacturers authorised distributor.**

**The Warranty will not apply where the equipment is modified, converted, or used for purposes other than those for which it was designed, unless clearance for the modifications etc. have been granted by Winget Limited in writing.**

**The Pre-delivery Inspection & Warranty Registration Document must be completed correctly and returned to Winget Limited within 7 days of the date of sale. Failure to do so could result in any subsequent Warranty claim being rejected.**

**No claim will be considered if other than genuine Winget Limited parts, which must be obtained via an authorised distributor,**

are used to effect a repair, or if lubricants other than those recommended by Winget Limited and the engine manufacturers are used.

The equipment must be serviced and maintained in accordance with the service schedules laid down in this handbook. Evidence that these have been complied with may be required before Warranty claims are reimbursed.

Winget Limited have a policy of continuous product improvement and reserve the right to change specifications without notice. No responsibility will be accepted for discrepancies, which may occur between the specification of machines and the descriptions contained in publications.

**Safety is the responsibility of all persons working with and around this machine. Think “SAFETY” at all times. *Read and remember the contents of this and the Engine Operators Handbook.***

**Any modifications to the machine will affect its working parameters and reduce built in safety factors. Refer to Winget Limited before fitting any non-standard equipment or parts. Winget Limited accept no responsibility for any modifications made after the machine has left the factory, unless previously agreed in writing. Winget Limited will accept no liability for damage to property, persons or the machine if failure is brought about due to such modifications, or fitment of spurious parts.**

**This machine produces water at HIGH PRESSURE and as such is potentially dangerous in operation. The high pressure water jet must never be directed at any person, animal or at any electrical equipment under any circumstances. If in doubt as to the suitability of this machine for a particular task refer to Winget Limited.**

***Never* commence work until the daily service checks have made carried out.**

***Always* report faults as soon as they are discovered.**

***Never* fill fuel tanks whilst the engine is running.**

***Never* leave the machine unattended with the engine running.**

***Never* attempt to disconnect the high pressure hose from the machine without first dumping any residual water pressure by first pulling the trigger gun (Engine stopped)**

***Never* use this equipment in areas of poor lighting.**

***Always* wear eye and ear protection when using this machine.**

***Always* keep the working area clear of people and animals**

***Always* stay alert and watch what you are doing.**

***Always*** be aware of the Lance Reaction Force when operating this machine.

***Always*** know how to stop the machine and bleed the water pressure quickly.

***Never*** over reach or stand on unstable supports, keep your footing and balance at all times.

***Never*** operate this machine from ladders or step ladders.

***Never*** allow the machine to run dry of water or serious permanent damage will be caused to the pump unit.

***Never*** run the machine for more than 5 minutes with the trigger gun in the closed position, this could result in a rapid rise in the water temperature, which may damage the seals in the pump.

***Never*** operate this machine under the influence of alcohol or drugs, (many forms of medication can cause drowsiness) or when tired.

***Never*** connect the machine to a hot water supply unless it is specifically designed to handle hot water.

***Always*** observe local Water Authority and Environment Agency Bylaws when connecting this equipment to a mains water supply.

***Always*** ensure the water supply is clean and free from contaminants.

***Never*** allow contaminated water to enter drains, sewers or local water courses.

***Never*** allow unauthorised or untrained personnel to operate this machine.

***Never*** operate on any inclined or unstable surface.

***Always*** drain the water from the hoses and pump on completion of work, especially in cold weather, to prevent serious damage do not allow the machine to freeze, protect from Frost.

***Never*** use ether based cold start aids in aerosol cans to aid cold or difficult starting.

***Never*** smoke whilst filling the fuel tank, mop up any fuel spills immediately and in any event before running the engine and allow time for any vapours from the spilled fuel to disperse before starting the engine.

***Never*** run the engine in an enclosed or confined area, exhaust fumes in enclosed areas can kill.

***Never*** stop diesel engines by means of the decompression lever, serious damage can be caused to the cylinder head, piston and valves.

***Always*** avoid contact with the exhaust muffler, this can get very hot when the engine is running and remains so for some time afterwards.

***Always*** “dump” residual water pressure from the system before leaving the machine. With the engine stopped pull the trigger until all pressure is dissipated

***Never*** leave the machine unattended with pressure in the water system.

***Always***, where possible, work on or close to engines or machinery when carrying out servicing or any maintenance, only when they are stopped, if this is not practical, remember to keep tools, test equipment and all parts of your person well away from moving parts.

***Always*** wear correctly fitting clothing when carrying out servicing, loose or baggy clothing can be extremely dangerous when working on running engines or machinery.

***Always*** “dump” pressure from the water system before carrying out any kind of maintenance or adjustment.

***Never*** allow unqualified personnel to attempt to repair, remove or replace any part of the machine.

***Always*** obtain advice before mixing oils; some are incompatible, if in doubt completely drain, flush and refill.

*Many* liquids used in this machine are harmful if taken internally or splashed into the eyes. In the event of accidentally swallowing oils or fuels, seek qualified medical assistance and advice.

*Always* dispose of waste oils and fuels into designated waste oil storage tanks. If storage tanks are not available, consult your distributor or local authority for the addresses of local designated disposal points. Improperly discarded waste oils pose a threat to wildlife. It is illegal to dispose of waste oil into drains, or water courses or to bury it. The Environment Agency have the power to impose heavy fines for breaches of the above advice.

*Never* allow oils and fuels to come into regular contact with skin. This can lead to serious skin diseases, including, medical evidence suggests, skin cancer. **ALWAYS** wear protective gloves when handling oils and fuels whether topping up, draining or refilling.

*Always* wash your hands if oils or fuels come into contact with the skin.

*Always* store fuels in small quantities in the correct specially designed containers, which can be securely fastened. Store fuel in a cool, well ventilated store away from sources of ignition.

*Always* stop up the fuel tank at the end of a working day or shift to prevent the formation of condensation on the inside of the fuel tank.

*Always* ensure that any Warning, Safety or Advisory Decals attached to the machine are legible and clean, replace if damaged, defaced or missing.

### **DIESEL POWERED UNITS ONLY**

To avoid damage to the water pump and gearbox never allow the engine to run on idle/tick over speed for prolonged periods of time.

### **ELECTRICAL STARTING SYSTEMS**

Starting engines fitted flywheel charge windings with the battery disconnected will cause irreparable damage unless the stator leads to the rectifier/regulator have been removed.

**ELECTRICAL STARTING SYSTEMS (Continued)**

**Never** remove any electrical cable while the battery is connected in the circuit.

**Only** disconnect the battery with the engine stopped and all switches in the off position

**Always** ensure that cables are fitted to their correct terminal, a short circuit or reversal of polarity will ruin diodes and transistors.

**Never** connect a battery into the system without checking that the voltage and polarity are correct.

**Never** flash any connection to check the current flow.

**Never** experiment with any adjustments or repairs to the system.

**Always** disconnect battery and charge windings before commencing any electric welding when a pole strap/earth lead is connected directly or indirectly to the engine.

Batteries contain sulphuric acid, which can cause severe burns, if acid is splashed onto the skin, eyes or clothes flush with copious amounts of fresh water and seek immediate medical aid.

**WARNING & ADVISORY DECALS**

The following warning and advisory decals are applied to the machine

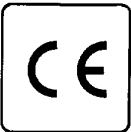

'CE' Decal



Wear Eye Protection



read operators manual

*Never commence work until the daily service checks have been carried out.*

### **WATER SUPPLY CONNECTION**

High speed pumps can be fed from mains water tap pressure (POSITIVE PRESSURE) or draw from a tank or sump via suction (NEGATIVE PRESSURE) however if used on suction (NEGATIVE PRESSURE) for prolonged periods premature seal wear is likely to result.

To run on either option please follow the instructions below:-

#### **MAINS TAP PRESSURE (POSITIVE)**

A clean water supply with a minimum of 15 Litres (3.3gallons) per minute flow rate with a minimum pressure of 2 Bar (30psi) is required. The inlet/supply hose should preferably have an internal bore dimension of 19mm (3/4") the minimum acceptable internal bore dimension is 13mm (1/2")

#### **DRAWING FROM A TANK OR SUMP-SUCTION (NEGATIVE)**

To use the machine to draw from a tank or sump the suction hose assembly should be used. The suction hose has an internal bore dimension of 19mm (3/4") and should be as short as possible. The "suction head " should be kept to a minimum and in any event should not exceed 610mm (2.0") The water should be clean and the tank/sump of sufficient capacity to prevent the pump running dry whilst in use.

**Never commence work until the daily service checks have been carried out.**

### **PRIMING THE WATER PUMP**

**Each time the machine is put into operation the water pump will require priming before it will operate correctly. Priming the pump and hoses removes any air which may be trapped in the system and which may affect the correct operation of the pump and prevent the full working pressure from being reached.**

**To prime the water pump follow the instructions below:-**

**Connect up the suction hose, if drawing from a tank keep the suction hose as short as possible and never exceed 3 metres.**

**Start the engine and run up to 3/4 full speed**

**Hold the trigger gun open until a constant flow of water emerges, this can take as long as 30 seconds, if after 30 seconds no water has emerged stop the engine and investigate the cause.**

**Close trigger, increase the engine speed and use in normal manner.**

**Never commence work until the daily service checks have been carried out.**

### **LOW PRESSURE CHEMICAL APPLICATION**

**The Low Pressure Chemical Application facility is an optional extra and may/may not be available on the machine.**

**Totally immerse the filter on the chemical suction hose in the chemical solution container, connect the opposite end of the hose to the chemical induction on the water pump.**

**The model PW9012 is provided with a metering control knob on the front panel of the machine when the Low Pressure Chemical Application facility is available. Turn the knob Anti-Clockwise to increase the flow of chemical, turn Clockwise to reduce the flow.**

**Dependant on the type of Lance supplied follow the instructions below induce the flow of chemical through the LANCE, Note chemical will only be induced at low pressure.**

**One-Piece Lance assembly, turn the chemical applicator at the end of the Lance anti-clockwise when viewed from the trigger gun. After a short delay chemical will be automatically dispensed. To stop the chemical application, turn the chemical applicator at the end of the lance clockwise. After a short delay whilst the residue of chemical works its way through the system the chemical flow will turn off completely.**

**Two-Piece Lance, the end of the lance has a Multireg nozzle system, this allows the angle of the spray to be adjusted by rotating the nozzle and the pressure to be lowered by pushing the nozzle away from the end of the lance. The amount of chemical flow induced is regulated by the knob on the control panel. To stop the flow of chemical, pull the nozzle assembly back towards the lance.**

**If chemicals have been used through the machine it is essential that clean water is allowed to flush through the system until the chemical residue completely disappears before the engine is stopped.**

**After the engine is stopped ensure all residual pressure in the system is released by pulling the trigger gun.**

**Never commence work until the daily service checks have been carried out.**

## **STARTING THE ENGINE**

### **Petrol Driven Units**

**Read the engine operators manual before attempting to start the engine.**

**Connect the inlet/suction hose to a suitable tap or completely immerse the inlet filter in the tank or sump. Turn on the tap**

**Ensure the lance is securely stowed**

**Turn on the fuel tap.**

**Close the choke lever, do not use the choke if the engine is warm or the ambient air temperature is high.**

**Turn the engine on/off switch to “on”**

**Move the throttle lever slightly to increase the speed, do not fully open the throttle at this stage.**

**Pull the starter grip lightly until resistance is felt, then pull briskly. Do not wrap the starter cord around the hand, serious personal injury could be sustained if the engine “kicks back” or backfires.**

**Open the choke as the engine warms up.**

**Prime the water pump as described above.**

**Open the throttle to the fully open position.**

**Do not allow the engine to run for more than 5 minutes with the trigger gun closed, the water temperature will rapidly rise and will cause damage to the water pump seals.**

### **MODEL PW200 ONLY**

**As water enters the pump it will discharge through the EASYSTART valve in the pump to atmosphere, this is correct. When the trigger**

gun is operated the EASYSTART valve will close and the water will stop discharging. Each time the trigger gun is closed water will discharge through the EASYSTART valve again. This is a built in safety feature of this unit to avoid overheating the pump and to ease starting. The EASYSTART valve also releases any residual pressure in the system automatically when the engine is stopped.

*Never commence work until the daily service checks have been carried out.*

## **STARTING THE ENGINE**

### **Diesel Driven Units**

Read the engine operators manual before attempting to start the engine.

Connect the inlet/suction hose to a suitable tap or completely immerse the inlet filter in the tank or sump. Turn on the tap

Ensure the lance is securely stowed

Turn on the fuel tap, if fitted.

Move the governor lever/engine stop control to the start position.

Most small diesel engines are fitted with automatic decompression levers, operate the lever as described in the engine operators manual.

Grasp the starter grip and pull lightly until resistance is felt, then return to the normal position. Still grasping the starter grip pull briskly with a “jerking” motion. The engine should now start running normally. If not, repeat the starting procedure. Do not wrap the starter cord around the hand, serious personal injury could be sustained if the engine “kicks back” or backfires.

Do not allow the engine to run for more than 5 minutes with the trigger gun closed, the water temperature will rapidly rise and will cause damage to the water pump seals.

To avoid damage to the water pump and gearbox (if fitted) never allow the diesel engine to run on idle/tick over speed for prolonged periods of time.

### **MODEL PW200 ONLY**

As water enters the pump it will discharge through the EASYSTART valve in the pump to atmosphere, this is correct. When the trigger gun is operated the EASYSTART valve will close and the water will stop discharging. Each time the trigger gun is closed water will discharge through the EASYSTART valve again. This is a built in safety feature of this unit to avoid overheating the pump and to ease starting. The EASYSTART valve also releases any residual pressure in the system automatically when the engine is stopped.

### **STOPPING THE ENGINE**

#### **Petrol Driven Units**

If the machine has been used to apply chemical ensure it is thoroughly flushed through with clean water before stopping the engine.

Close the fuel tap and turn the engine switch to off, release any residual pressure in the system by pulling the trigger gun.

In an EMERGENCY turn the engine switch to off.

### **STOPPING THE ENGINE**

#### **Diesel Driven Units**

If the machine has been used to apply chemical ensure it is thoroughly flushed through with clean water before stopping the engine.

In an EMERGENCY move governor lever/engine stop control to the stop position.

Never stop diesel engines by means of the decompression lever, serious damage can be caused to the cylinder head, piston and valves.

**DAILY SERVICE CHECKS**

Read the engine operators manual for items in addition to those listed below.

Check condition of suction and pressure hose and lance.

Check suction filter, (if fitted)

Check the fuel level.

Check condition of air filter element, and clean replace as necessary.

Check the oil levels in the engine, gearbox if fitted, and pump. Refer to the engine operators handbook for advice on checking engine oil level and for the correct grade of engine oil. Pumps and gearboxes are fitted with either sight glasses or level plugs/dipsticks.

In the case of sight glasses the oil level is correct when it is halfway up the glass, some sight glasses are marked with a red dot to indicate the correct level.

In the case of level plugs the oil level is correct when the oil is level with the bottom of the threaded hole or if it just begins to trickle out when the plug is removed.

In the case of dipsticks the correct level will be marked on the dipstick.

Top up with the correct grade of oil, refer to the engine operators handbook or the Technical Information section later in this handbook.

If fitted, check tyre pressures.

Check the security of any covers or guards, do not use if any are missing.

Check the security of engine/gearbox/water pump retaining nuts and bolts.

Check all controls for correct operation.

Report any faults or missing equipment or damage immediately.

### **WEEKLY SERVICE CHECKS**

Read the engine operators manual for items in addition to those listed below.

All the daily service checks plus check condition of water filter and clean as necessary, the water filter is normally located in the water inlet port of the pressure relief valve, see page 20 to identify the type of filter installed.

### **FIRST 20 HOURS**

Change engine, pump and gearbox oils. Refer to the engine operators manual for the correct grade of engine oil. Refer to the Technical Information section later in this manual for the correct grade of pump and gearbox oils.

### **EVERY 150 HOURS**

Read the engine operators manual for items in addition to those listed below.

Change pump and gearbox oils.

Refer to the Technical Information section later in this manual for the correct grade of pump and gearbox oils.

### **Every 500 HOURS OR ANNUALLY**

Read the engine operators manual for items in addition to those listed below.

Change pump and gearbox oils.

Refer to the Technical Information section later in this manual for the correct grade of pump and gearbox oils.

INLET FILTERS-IDENTIFICATION



CLEAN OR REPLACE INLET FILTERS FREQUENTLY

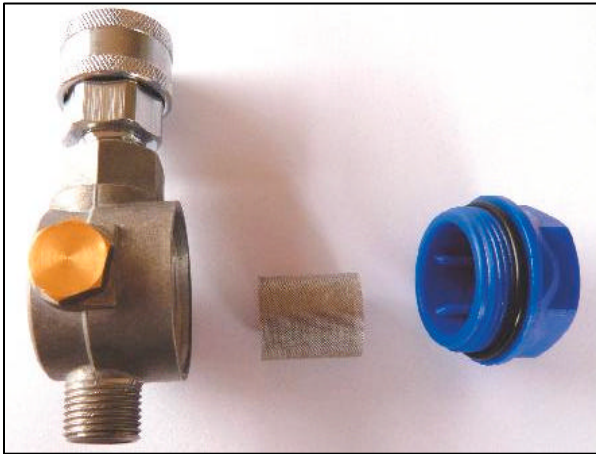

Filter Type A







Filter Type B

FAULT	CAUSE	REMEDY
Pump running normally but pressure low on installation	Inlet Filter blocked or dirty Pump sucking air  Valves sticking Unloader valve seat faulty	Check & Clean Inlet Filter Check water supply & possibility of air ingress. Check & clean or replace. Check & replace if required.
Pump running normally but pressure low on installation	Inlet Filter blocked or dirty Nozzle incorrectly sized Worn piston packing	Check & Clean Inlet Filter Check & replace if required Check & replace if required
Fluctuating pressure	Inlet Filter blocked or dirty Valves worn Blockage in valve Pump sucking air  Worn piston packing	Check & Clean Inlet Filter Check & replace if required. Check & clean if required. Check water supply & air ingress at joints in suction line. Check & replace if required.
Pressure low after period of normal use	Inlet Filter blocked or dirty Nozzle worn Suction or delivery valves worn or blocked Worn piston packing	Check & Clean Inlet Filter Check & replace if required. Check & replace if required.  Check & replace if required.
Pump noisy	Inlet Filter blocked or dirty Air in suction lines  Broken or weak suction or delivery valve springs Foreign matter in the valves Worn bearings Excessive temperature of water	Check & Clean Inlet Filter Check water supply & connections in suction line. Check & replace if required.  Check & clean if required. Check & replace if required. Reduce below 75 centigrade.
Presence of water in the oil	Oil seals worn High Humidity in the air  Piston packing worn	Check & replace if required. Check & reduce oil change intervals. Check & replace if required.
Water dripping from below pump	Piston packing worn Plunger retainer O ring worn Leaking connections	Check & replace if required. Check & replace if required. Check & tighten or reseal.
Oil dripping	Oil seal worn	Check & replace if required.
Excessive vibration in the delivery line	Inlet Filter blocked or dirty Valves probably blocked	Check & Clean Inlet Filter Check & clean if necessary.
Engine will not start	Switch in correct position Fuel line is switched off. Battery flat Oil Alert activated (if fitted)	Check & correct. Check fuel line & tank. Check battery connections. Check engine oil level.
No water from nozzle	Inlet Filter blocked or dirty Unloader in constant by-pass Blocked nozzle	Check & Clean Inlet Filter Check & turn knob to pressure. Check & clean if necessary.

# TECHNICAL INFORMATION

22

Model	Pressure Psi/Bar	Engine	Flow Ltr/min	Gearbox Type	Pump Type	Weight (Kg)	Dimensions HxWxL(mm)
 PW90PH12	1350/90	Honda Petrol GX120	12	N/A	W1210	30	440x340x520
 PW100PH11 PW100PH12 PH150PH8	1500/100 1500/100 2250/150	Honda Petrol GX120 GX160 GX160	11 12 8	N/A	WW909 WW909 TT1508	30	470x410x540
 PW140PH12	2000/140	Honda Petrol GX160	12	YES	W140	42	510x450x600
 PW140PH12T	2000/140	Honda Petrol GX160	12	YES	W140	48	640x600x1000
 PW100PH10GCC PW150PH12GC PW150PH12GCC	1500/100 2250/150 2250/150	Honda Petrol GC135 GC190 GC190	10 12 12	N/A	AXD2520 TT512C AXD3026	32 34 34	820x530x790
 PW150PH14 PW170PH15 PW200PH13 PW170DY15E	2250/150 2450/170 3000/200 2450/170	Honda Petrol GX200 GX270 GX270 Yanmar Diesel L70	14 15 13 15	YES N/A N/A N/A	W154 WW961 UH2013 WW961	44 56 57 75	800x550x660
 PW200PH15 PW200PH21	3000/200 3000/200	Honda Petrol GX340 GX390	15 21	YES YES	WS201 WS202	85 86	720x600x990
 PW200DY15E	3000/200	Yanmar Diesel L100	15	YES	WS201	128	780X660X1015

 <p><b>PW200DY15ES</b></p>	<p><b>3000/200</b></p>	<p><b>Yanmar Diesel L100</b></p>	<p><b>15</b></p>	<p><b>YES</b></p>	<p><b>WS201</b></p>	<p><b>148</b></p>	<p><b>850x600x100</b></p>
--	------------------------	--	------------------	-------------------	---------------------	-------------------	---------------------------

**LUBRICANTS**

**Water Pumps**

**SAE20W/50 Engine oil**

**Gearbox**

**SAE90 Gear Oil**

**Engines**

**Yanmar L100 Diesel:- 10W30 or 20W40 API Classification CD**

**Honda Petrol Engines- 10W30, 10W40, 15W40 API Classification SF or SH**

# WINGET PRESSURE WASHERS



## PARTS SECTION

# SERIES 44 PLUNGER PUMP FOR MODEL PW140

## SERIES "44" PW140

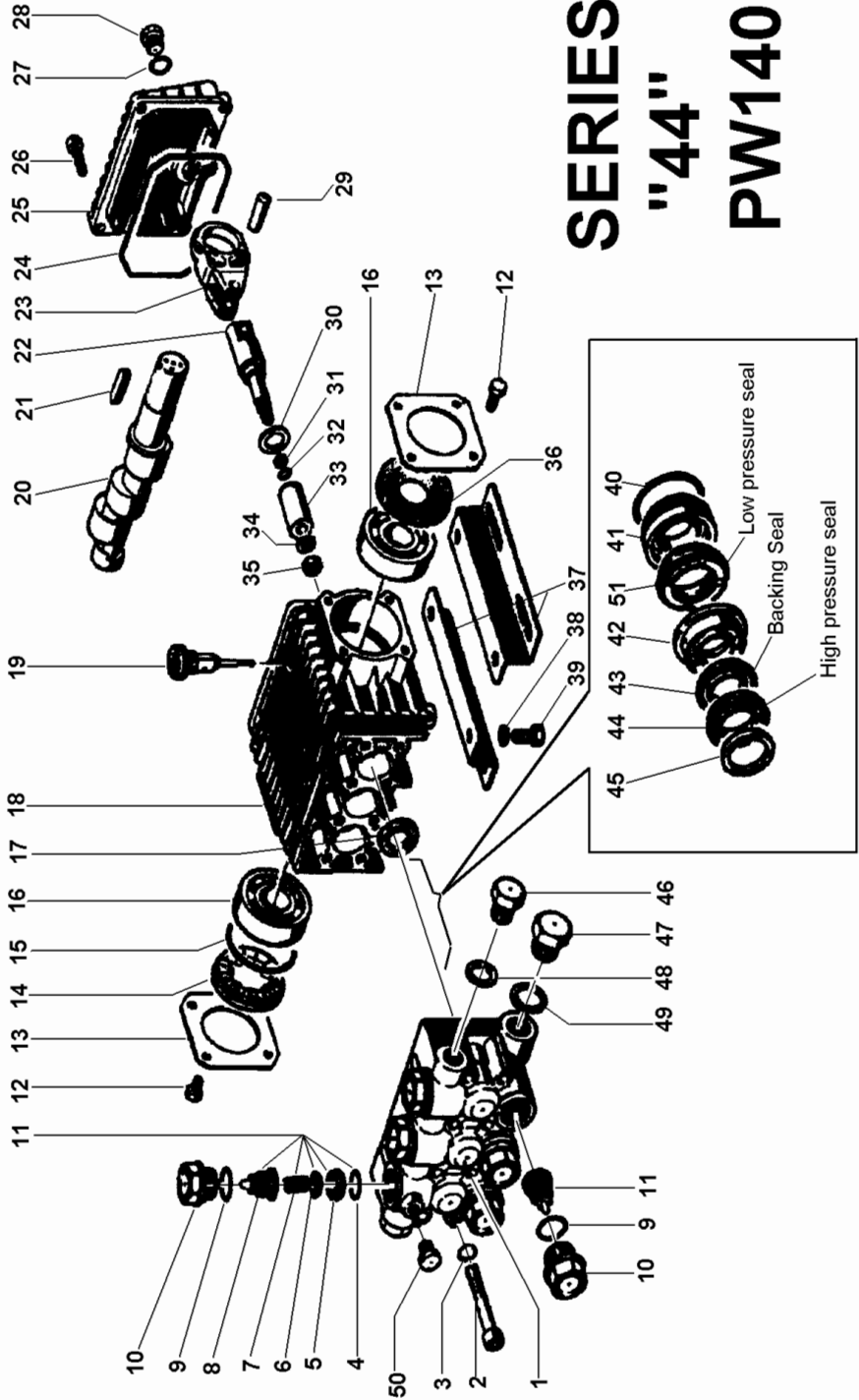

# CONTROL SET W2-W2L FOR MODEL PW140

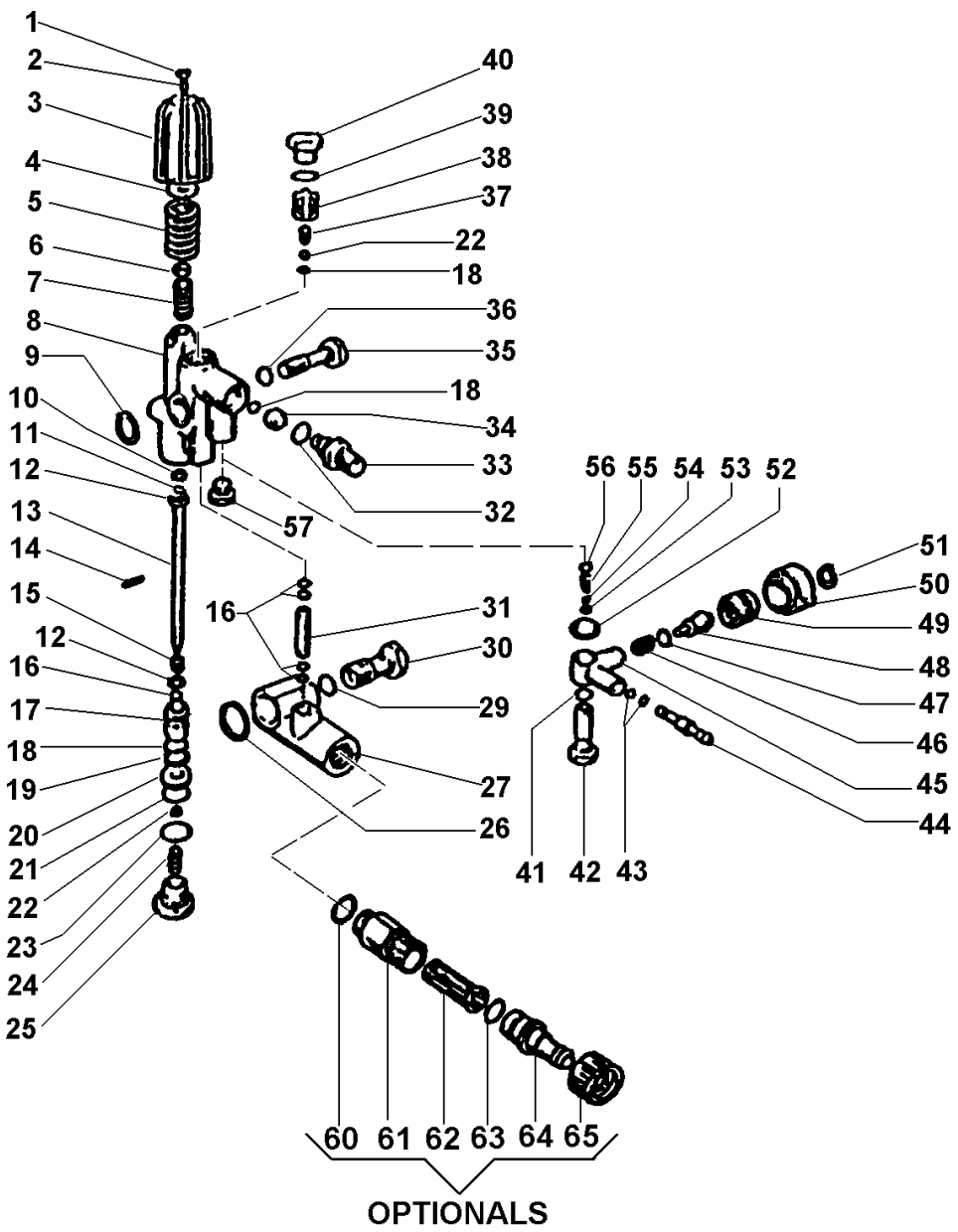

# RS99 REDUCTION GEARBOX FOR MODEL PW140

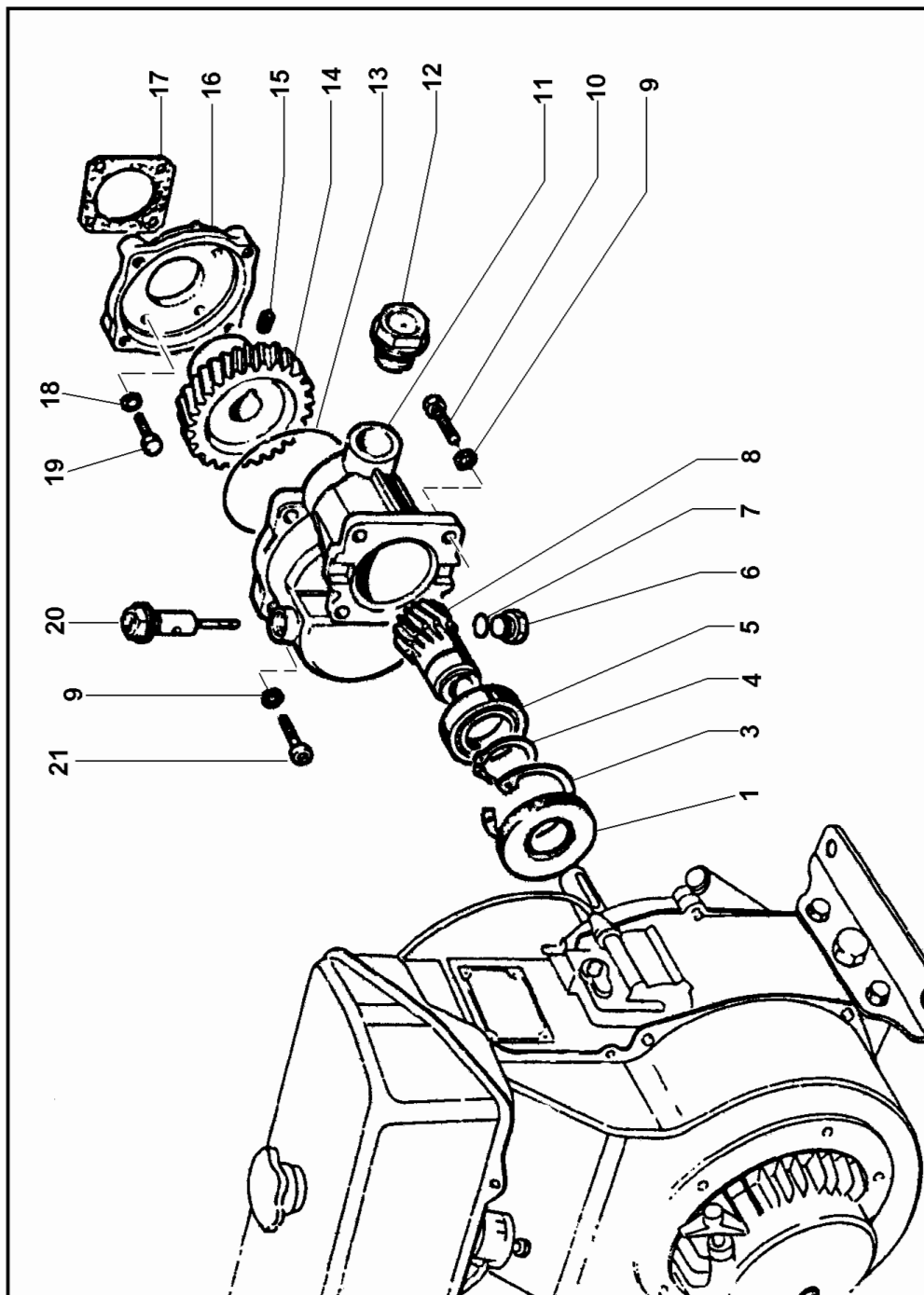

# VERSION V BUILT IN UNLOADER FOR PW140

## Series 44

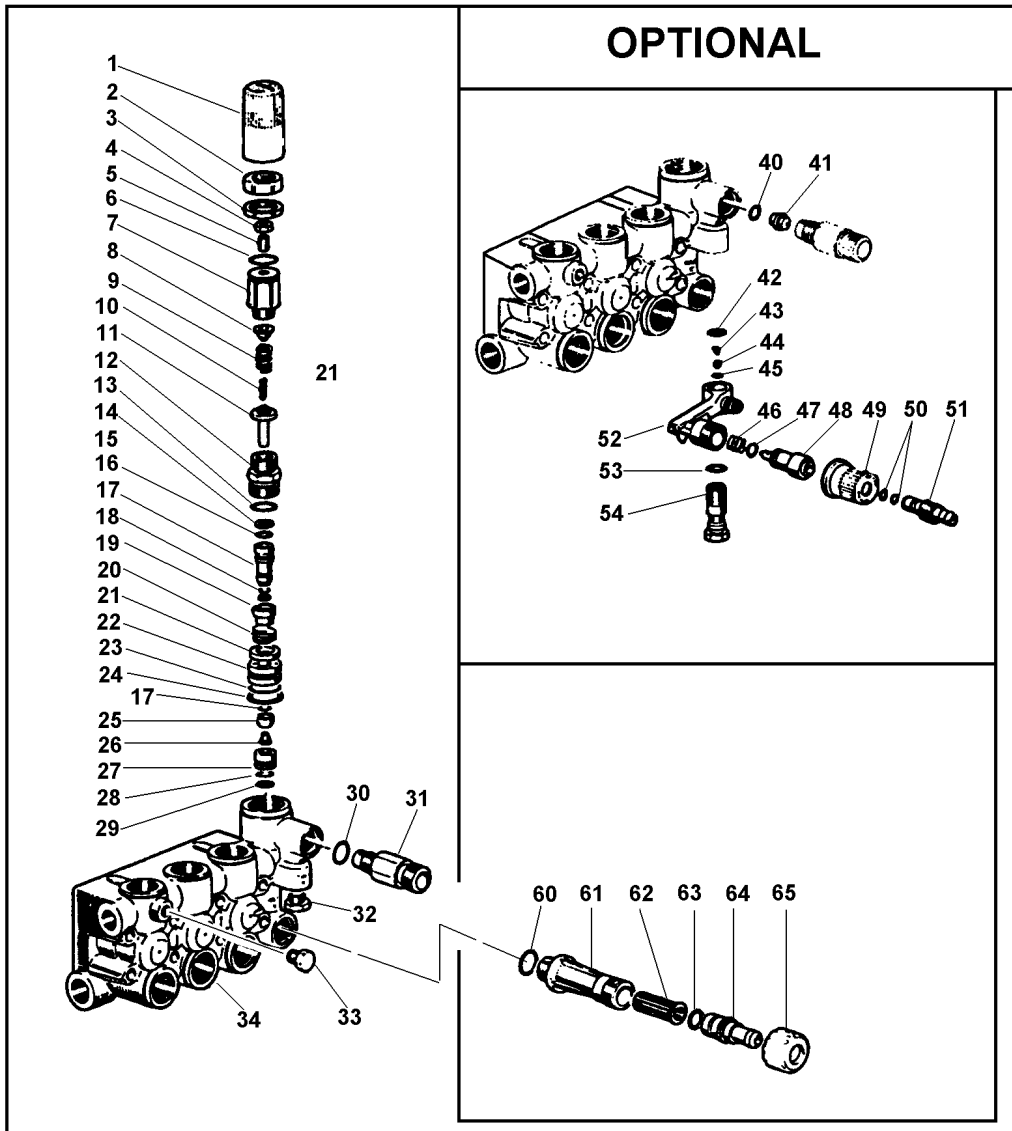

# SERIES WS201 PLUNGER PUMP FOR PW200

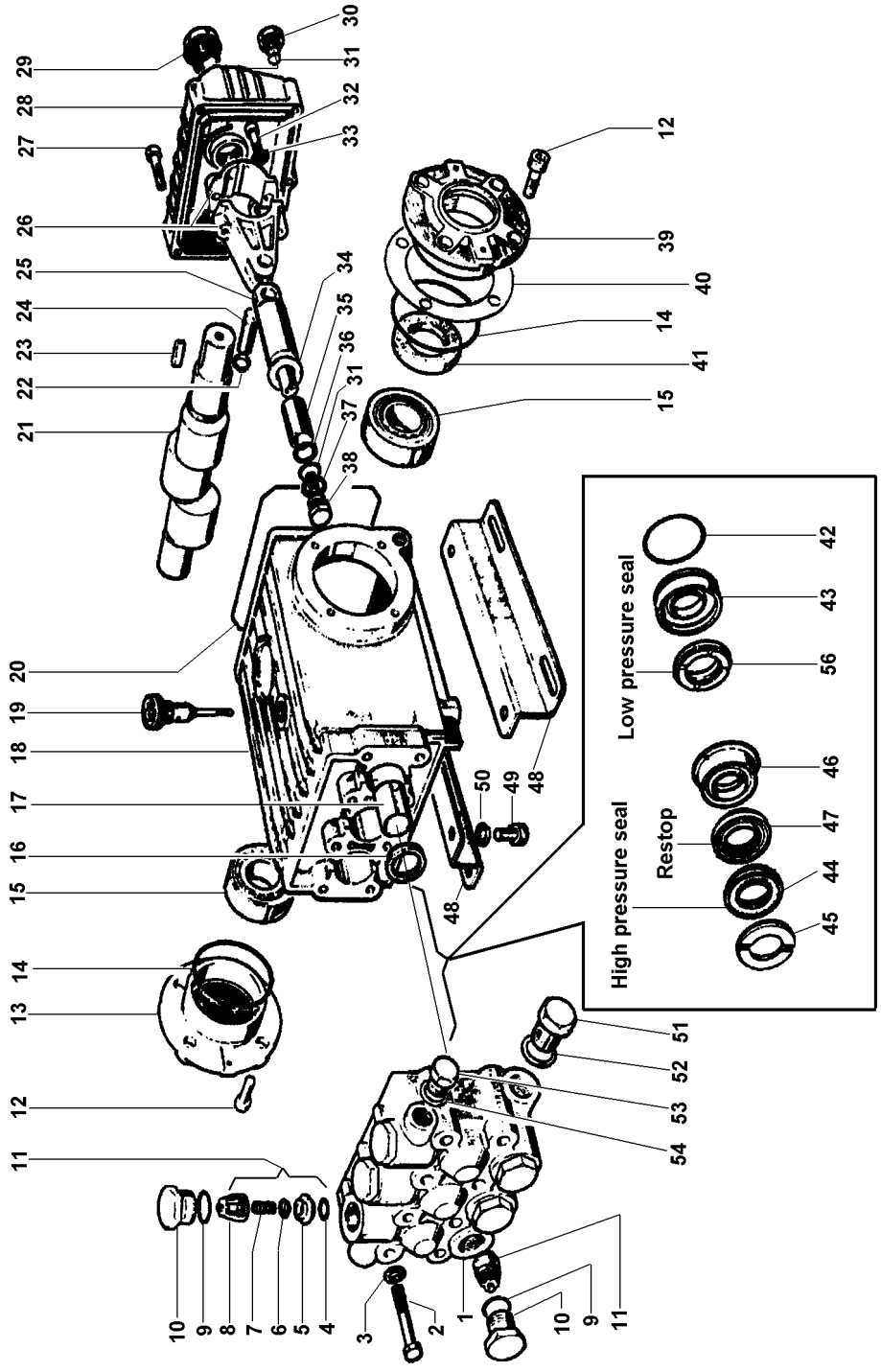

# RS151 REDUCTION GEARBOX FOR PW200

RS151

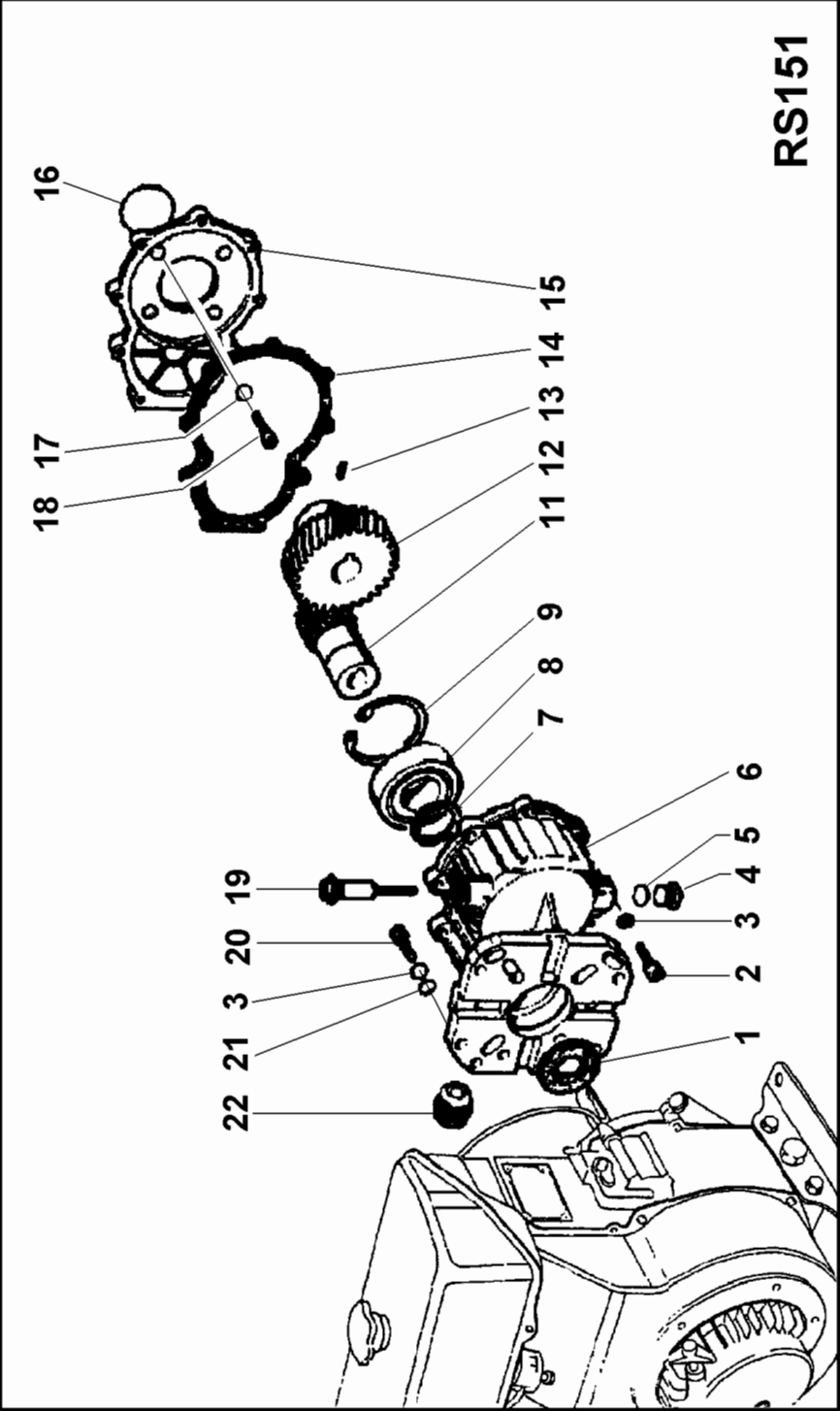

# VRM UNLOADER VALVE ART612 FOR PW200

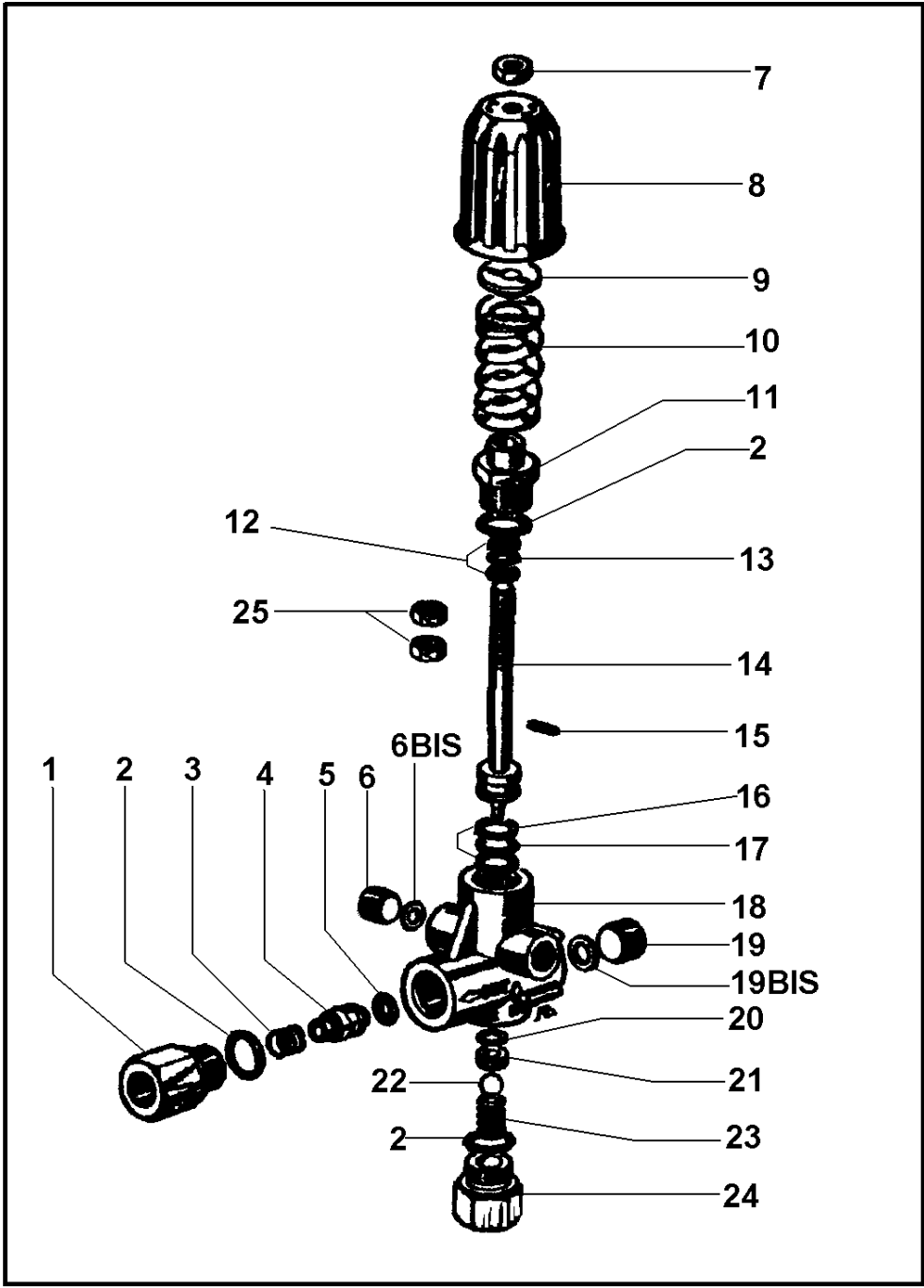

# QUICK CONNECTION FOR PW200

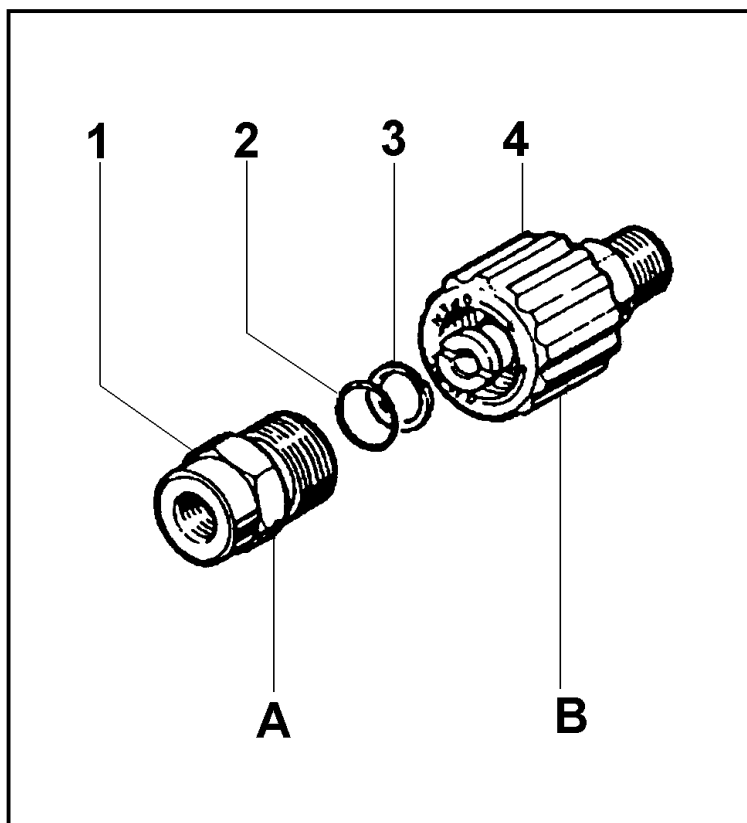

# SERIES W1507 PUMP FOR PW9012 (NPP12/9)

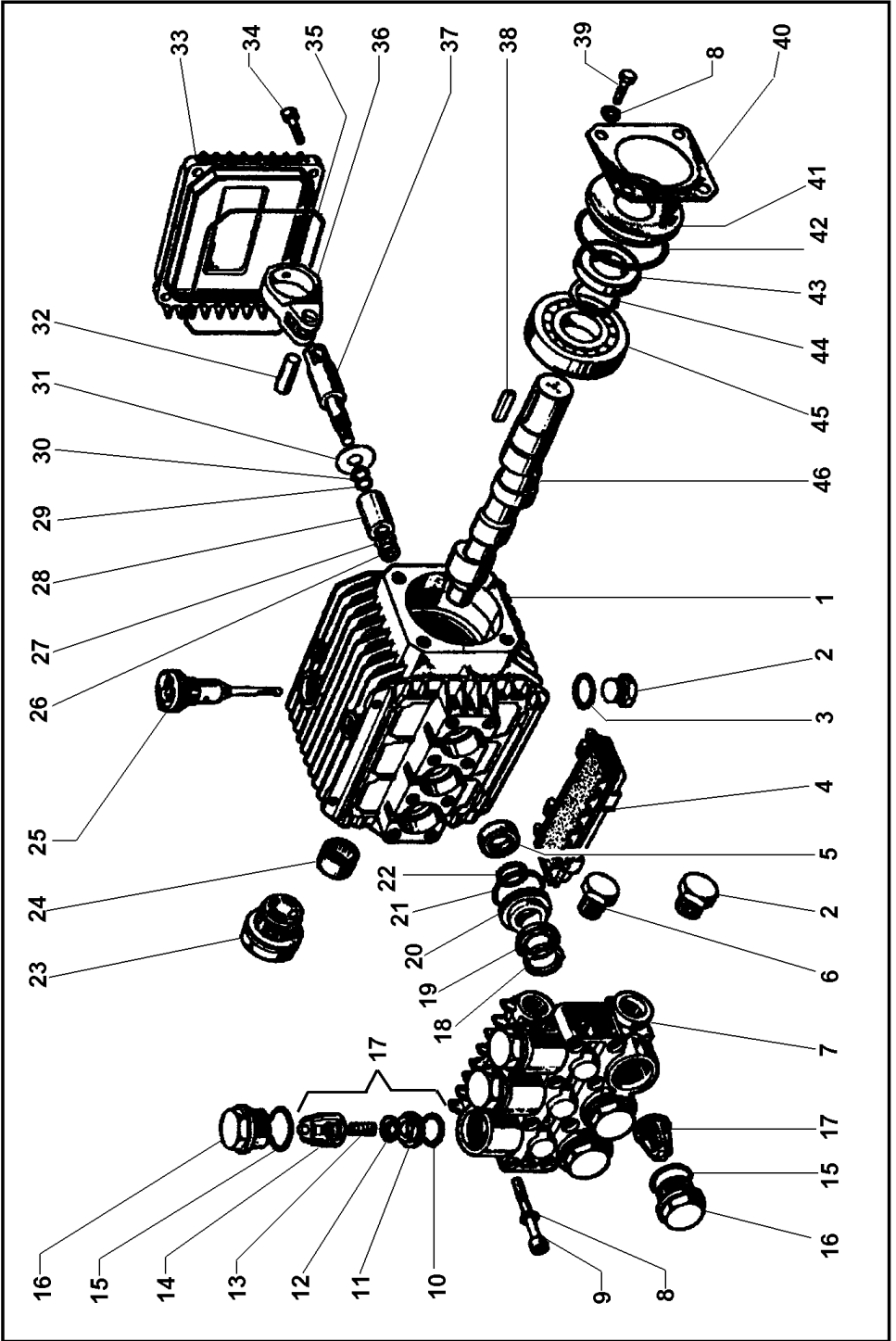

# VERSION V UNLOADER VALVE FOR PW9012

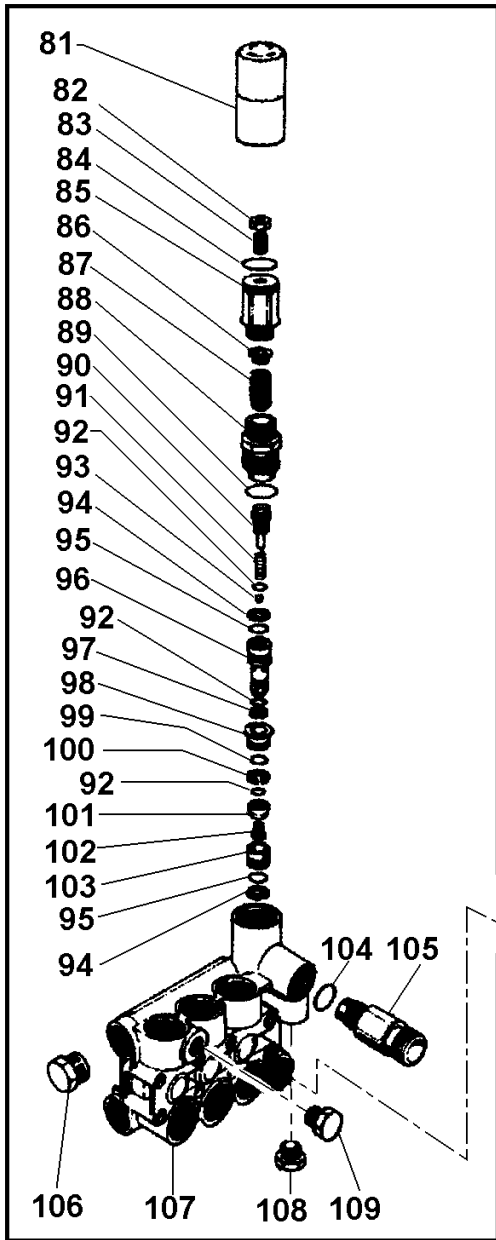

## OPTIONAL

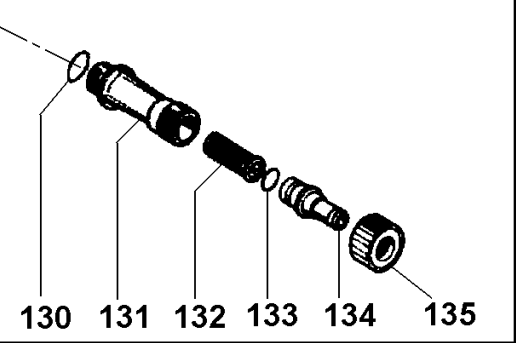
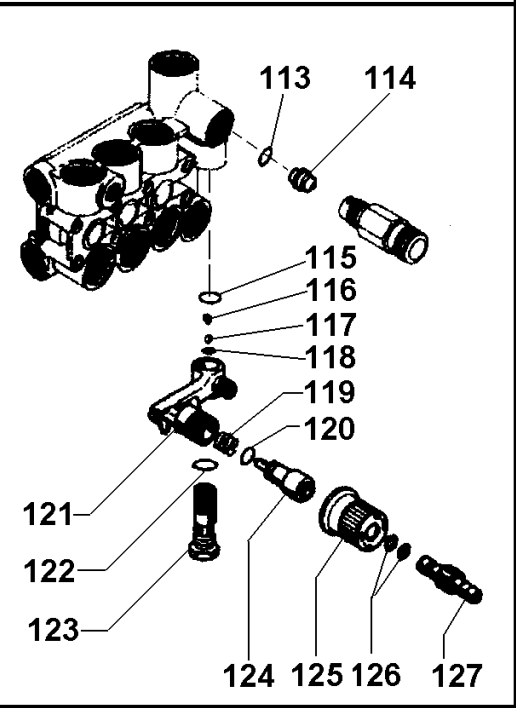

# SHAFTS & FLANGES VERSION A-B-C FOR PW9012

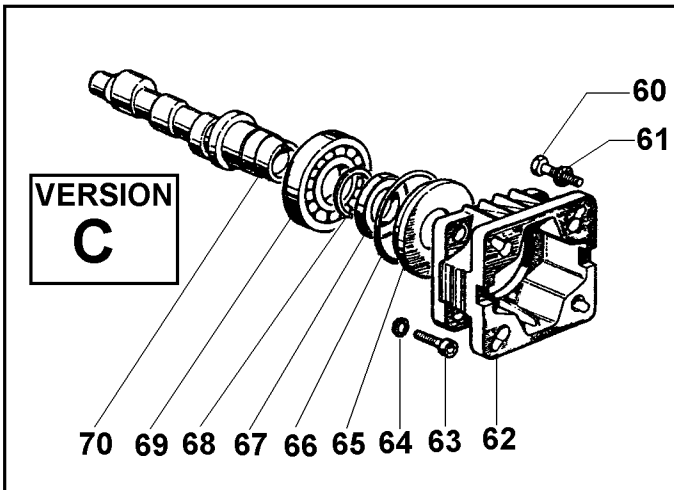
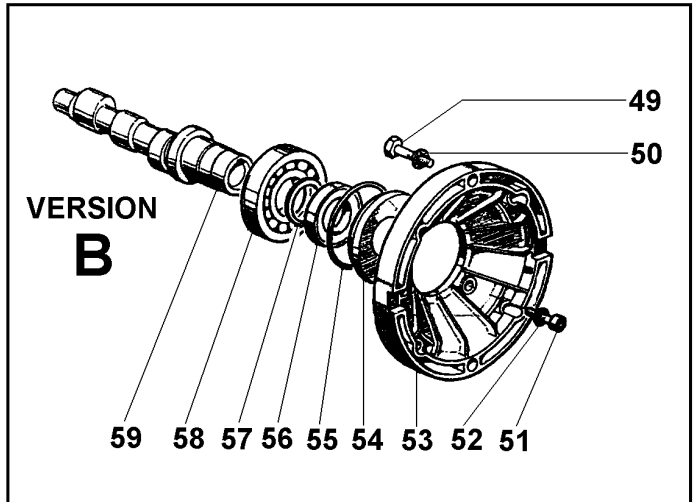
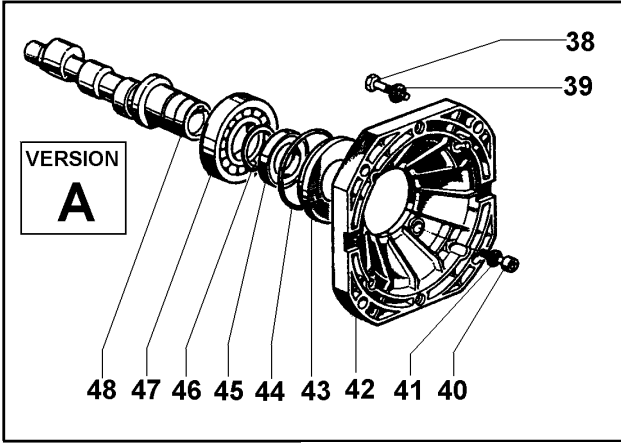

# SERIES 1511 PLUNGER PUMP FOR PW100PH11

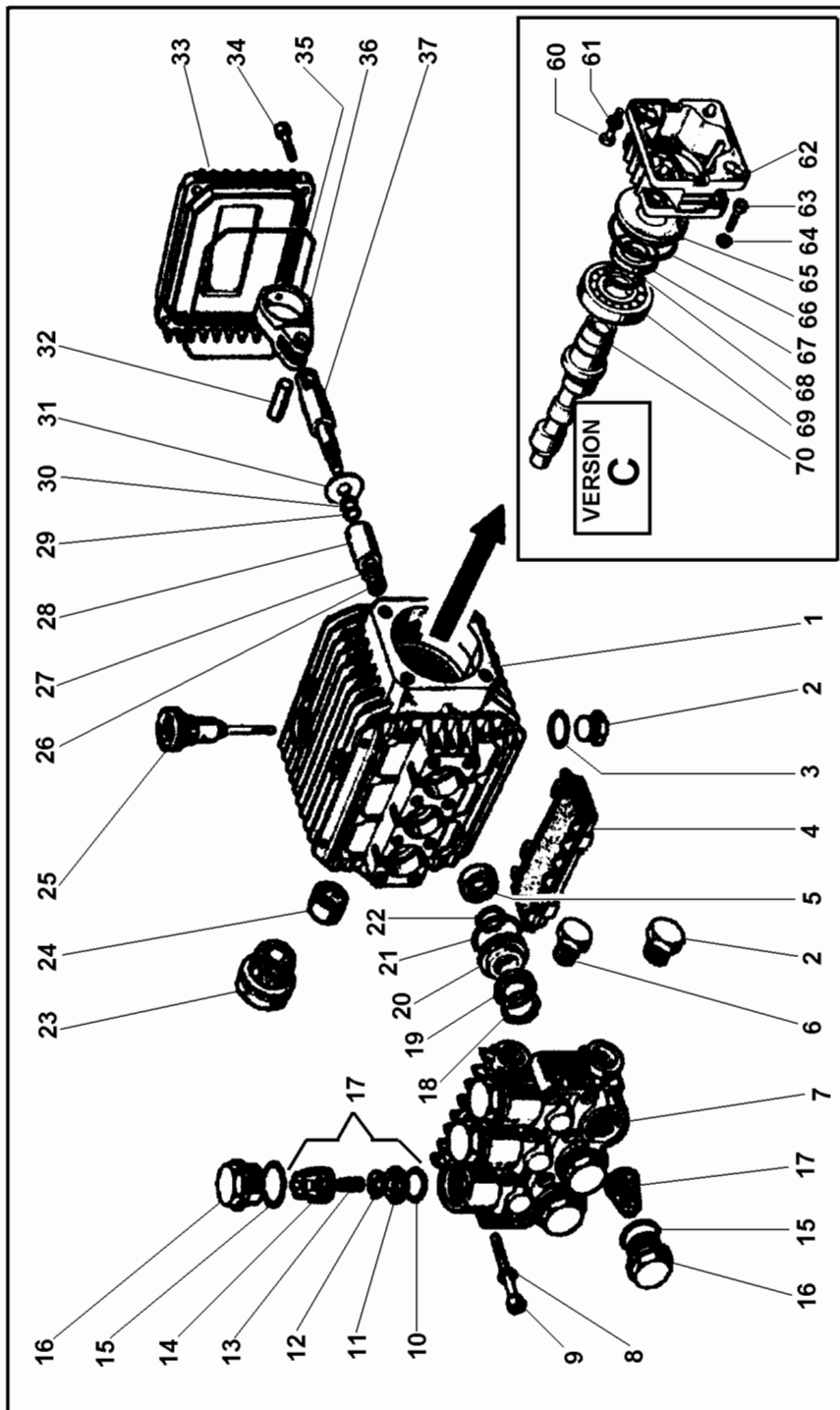

# WW1511V UNLOADER VALVE FOR PW100PH11

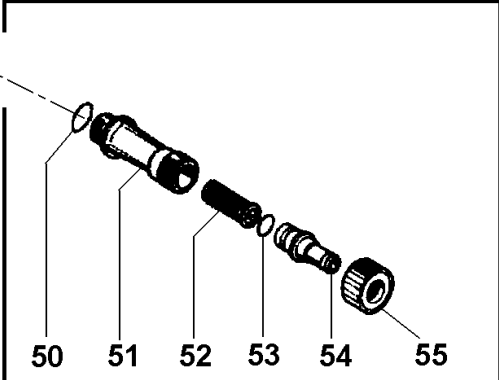
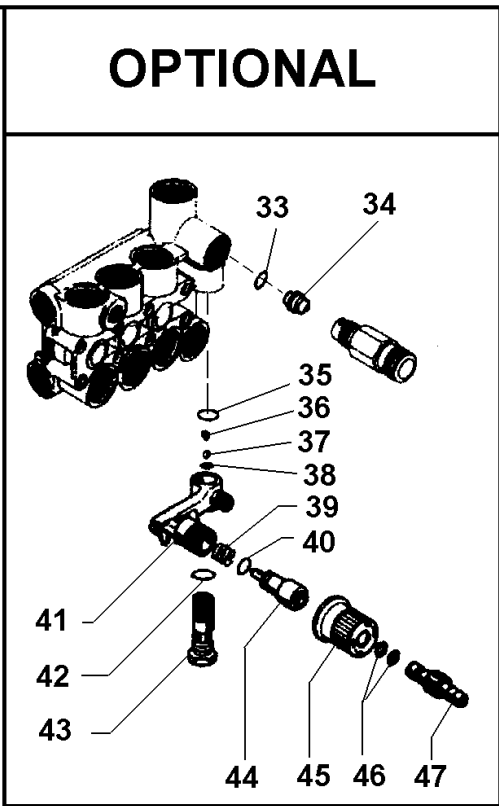
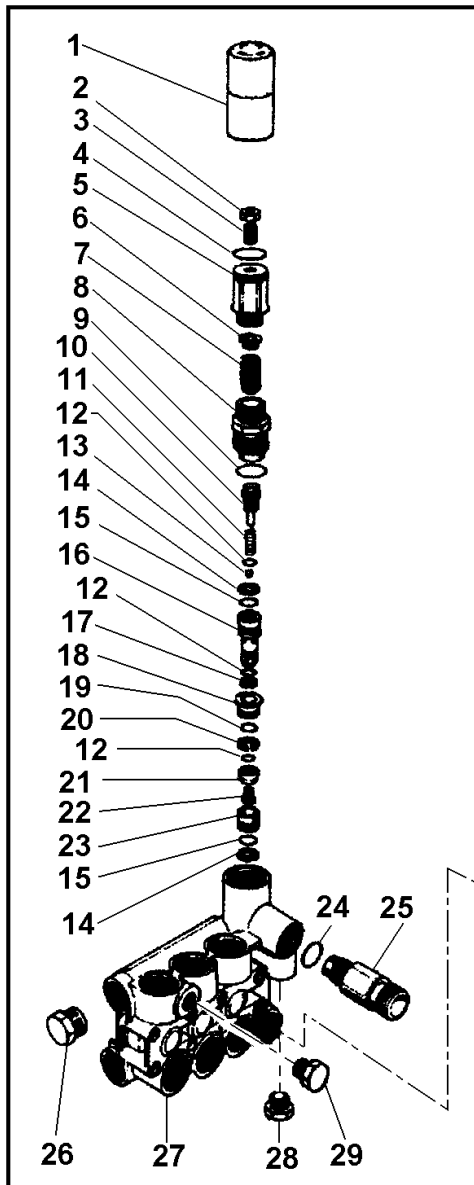

# **CALIFORNIA**

## **Proposition 65 Warning**

**Diesel engine exhaust and some of its constituents are known to the State of California to cause cancer, birth defects and other reproductive harm**